



MEGALINE

For Extra Large Pitches



METRIC

VARDEX

Advanced Threading Solutions

MEGALINE

For Extra Large Pitches—Up to 25mm or 1 tpi

Unique Design for Heavy Duty Applications

VKX—Vargus Tough
Submicron Grade Inserts

Anti-Rotation Stopper

Toolholder Support
Suited to Insert Profile

Mega Line

■ ISO Inserts & Toolholders	Pages 4-5
■ Round (DIN 20400) Inserts & Toolholders	Pages 6-7
■ Trapez Inserts & Toolholders	Pages 8-9
■ ACME Inserts & Toolholders	Pages 10-11
■ Stub ACME Inserts & Toolholders	Pages 12-13
■ American Buttress Inserts & Toolholders	Pages 14-15
■ Metric Buttress (Sägengewinde) Inserts & Toolholders	Pages 16-17

TECHNICAL DATA

■ Recommended Grades and Cutting Speeds	Page 18
---	---------

Mega Line Ordering Code System

Inserts

5	MG	E	R	20	TR	VKX
1	2	3	4	5	6	7

1-Insert Size 5-IC5/8	2-Product Line MG-Mega Line	3-Type of Insert E-External I-Internal	4-RH/LH Insert R-Right Hand L-Left Hand	5-Pitch 10-25mm 2-1 tpi	6-Standard ISO Metric RD-Round DIN 20400 TR-Trapez DIN 103 ACME-ACME STACME-Stub ACME ABUT-American Buttress SAGE-Metric Buttress DIN 513
---------------------------------	---------------------------------------	---	--	--------------------------------------	---

7-Grade VKX

External Toolholders

N	L	32	-	5	MG	24	TR	LH
1	2	3		4	5	6	7	8

1-Anvil N-No anvil	2-Holder Style L-External	3-Shank Square [mm] 25, 32, 40	4-Insert Size 5-IC5/8	5-Product Line MG-Mega Line	6-Pitch 10-25mm 2-1 tpi
------------------------------	-------------------------------------	--	---------------------------------	---------------------------------------	--------------------------------------

7-Standard	
ISO Metric	STACME-Stub ACME
RD-Round DIN 20400	ABUT-American Buttress
TR-Trapez DIN 103	SAGE-Metric Buttress DIN 513
ACME-ACME	

8-RH/LH Holder
None-Right Hand
LH-Left Hand

Internal Toolholders

N	VR	C	40	-	5	MG	24	TR	LH
1	2	3	4		5	6	7	8	9

1-Anvil N-No anvil	2-Holder Style VR-Internal	3-Cooling C-With Coolant Channel	4-Shank Front Dia. 40, 50, 60	5-Insert Size 5-IC5/8	6-Product Line MG-Mega Line	7-Pitch 10-25mm 2-1 tpi
------------------------------	--------------------------------------	--	---	---------------------------------	---------------------------------------	--------------------------------------

8-Standard	
ISO Metric	STACME-Stub ACME
RD-Round DIN 20400	ABUT-American Buttress
TR-Trapez DIN 103	SAGE-Metric Buttress DIN 513
ACME-ACME	

9-RH/LH Holder
None-Right Hand
LH-Left Hand



Tool Selector and CNC Program Generator

The most popular and advanced thread turning and thread milling software on the market today.

Now available in 2 versions at www.vargus.com:

- Online Version
 - Online interactive software
 - For the most popular web browsers
 - Most updated version always online
- Desktop (Downloadable) Version
 - Standalone software application
 - MS Windows OS-based program
 - Automatic updates



ISO Inserts

External / Internal

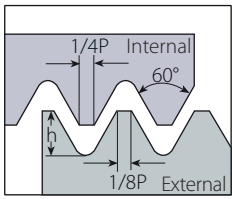

Defined by: R262 (DIN 13)
Tolerance class: 6g/6H

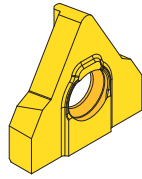

Internal

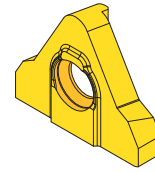
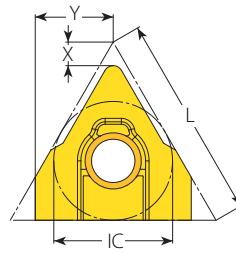

External

External

	Insert size		Pitch	Ordering Code	Dimensions mm			Number of Passes	
	IC	L mm	mm	RH	h min	X	Y	0.07mm-Min. Depth of Cut (On radius)	0.15mm-Max. Depth of Cut (On radius)
	5/8" MG	27	12.0	5MGER 12.0ISO...	7.36	4.08	11.3	105	49
			16.0	5MGER 16.0ISO...	9.82	4.66		140	66
			18.0	5MGER 18.0ISO...	11.04	4.95		158	74
			20.0	5MGER 20.0ISO...	12.27	5.24		175	82
			25.0	5MGER 25.0ISO...	15.34	4.46		219	102

Internal

	Insert size		Pitch	Ordering Code	Dimensions mm			Number of Passes	
	IC	L mm	mm	RH	h min	X	Y	0.07mm-Min. Depth of Cut (On radius)	0.15mm-Max. Depth of Cut (On radius)
	5/8" MG	27	12.0	5MGIR 12.0ISO...	6.94	2.65	10.4	99	46
			16.0	5MGIR 16.0ISO...	9.32	3.01		132	62
			18.0	5MGIR 18.0ISO...	10.49	3.15		149	69
			20.0	5MGIR 20.0ISO...	11.63	3.29		165	77
			25.0	5MGIR 25.0IRSO...	14.57	3.65		206	96

Recommended thread infeed method for Mega Line: Flank or Modified Flank 1°

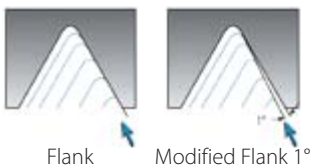

Toolholders for ISO Inserts

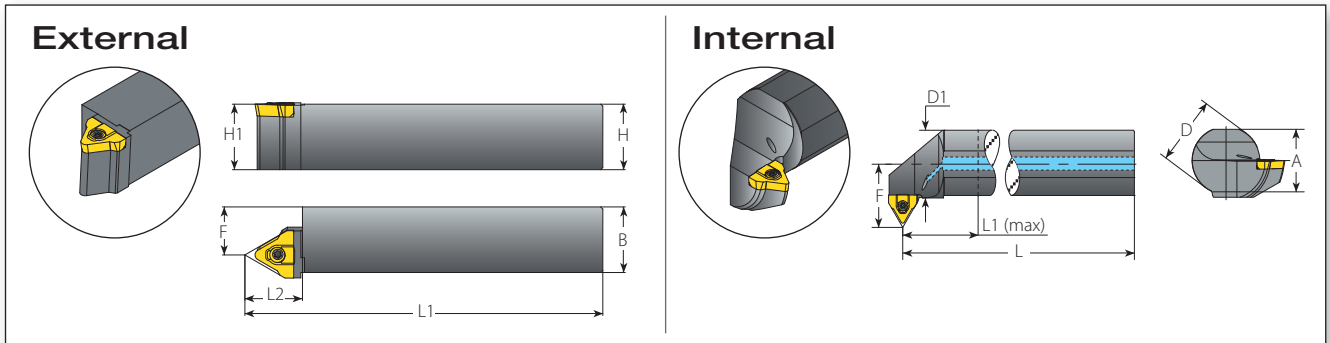

External

Insert	Ordering Code		Dimensions			Thread Diameter Range (Min.-Max.)	
	RH	H=B=H1	F	L1	L2		
5MGER 12.0ISO...	NL25-5MG 12ISO	25	16.5	155			
	NL32-5MG 12ISO	32	23.5	175	22		M43x12
	NL40-5MG 12ISO	40	31.5	205			
5MGER 16.0ISO...	NL25-5MG 16ISO	25	16.5	155			
	NL32-5MG 16ISO	32	23.5	175	22		M57x16
	NL40-5MG 16ISO	40	31.5	205			
5MGER 18.0ISO...	NL25-5MG 18ISO	25	16.5	155			
	NL32-5MG 18ISO	32	23.5	175	22		M65x18
	NL40-5MG 18ISO	40	31.5	205			
5MGER 20.0ISO...	NL25-5MG 20ISO	25	16.5	155			
	NL32-5MG 20ISO	32	23.5	175	22		M72x20
	NL40-5MG 20ISO	40	31.5	205			
5MGER 25.0ISO...	NL25-5MG 25ISO	25	16.5	155			
	NL32-5MG 25ISO	32	23.5	175	22		M90x25
	NL40-5MG 25ISO	40	31.5	205			

Internal

Insert	Ordering Code		Dimensions					Min. Bore dia.	Thread Diameter Range (Min.-Max.)	
	RH	A	L	L1 (max)	D	D1	F		mm	Short Chip Material
5MGIR 12.0ISO...	NVRC40-5MG 12ISO	36	232.5	100	40	39.7	41.5	60.0	(M73-90)x12	(M85-90)x12
	NVRC50-5MG 12ISO	46	257.5	125	50	49.7	46.5	70.0	(M83-90)x12	(M83-90)x12
5MGIR 16.0ISO...	NVRC40-5MG 16ISO	36	232.5	100	40	39.7	41.5	59.7	(M77-190)x16	(M89-190)x16
	NVRC50-5MG 16ISO	46	257.5	125	50	49.7	46.5	69.7	(M87-190)x16	(M101-190)x16
	NVRC60-5MG 16ISO	57	282.5	150	60	59.7	51.5	79.7	(M97-190)x16	(M113-190)x16
5MGIR 18.0ISO...	NVRC40-5MG 18ISO	36	232.5	100	40	39.7	41.5	65.5	(M85-230)x18	(M91-230)x18
	NVRC50-5MG 18ISO	46	257.5	125	50	49.7	46.5	69.5	(M89-230)x18	(M103-230)x18
	NVRC60-5MG 18ISO	57	282.5	150	60	59.7	51.5	79.5	(M99-230)x18	(M115-230)x18
5MGIR 20.0ISO...	NVRC40-5MG 20ISO	36	232.5	100	40	39.7	41.5	70.4	(M92-290)x20	(M93-290)x20
	NVRC50-5MG 20ISO	46	257.5	125	50	49.7	46.5	70.4	(M92-290)x20	(M105-290)x20
	NVRC60-5MG 20ISO	57	282.5	150	60	59.7	51.5	79.4	(M101-290)x20	(M117-290)x20
5MGIR 25.0ISO...	NVRC40-5MG 25ISO	36	232.5	100	40	39.7	41.5	82.0	(M109-405)x25	(M109-405)x25
	NVRC50-5MG 25ISO	46	257.5	125	50	49.7	46.5	82.0	(M109-405)x25	(M110-405)x25
	NVRC60-5MG 25ISO	57	282.5	150	60	59.7	51.5	82.0	(M109-405)x25	(M122-405)x25

Spare Parts for the above toolholders (external and internal): Insert Screw - S5MG

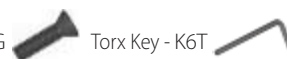

Torx Key - K6T

Round (DIN 20400) Inserts

External / Internal

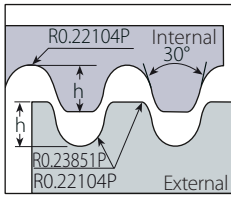

Defined by: DIN 20400
Tolerance class: Standard

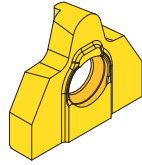

Internal

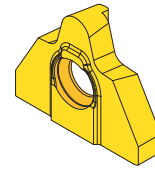
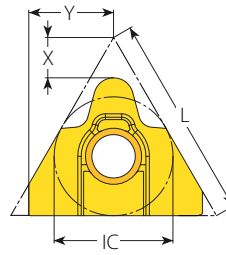

External

External



Insert size	Pitch	Ordering Code	Dimensions mm			Number of Passes		
			IC	L mm	RH	h min	X	Y
5/8" MG	27	5MGER 10.0RD20400...	10.0	5.50	4.12	11.3	78	36
		5MGER 12.0RD20400...	12.0	6.60	5.39		93	43
		5MGER 16.0RD20400...	16.0	8.80	4.92		124	58

Internal



Insert size	Pitch	Ordering Code	Dimensions mm			Number of Passes		
			IC	L mm	RH	h min	X	Y
5/8" MG	27	5MGIR 10.0RD20400...	10.0	5.50	4.12	10.4	78	36
		5MGIR 12.0RD20400...	12.0	6.60	5.39		93	43
		5MGIR 16.0RD20400...	16.0	8.80	4.92		124	58

Recommended thread infeed method for Mega Line: Flank or Modified Flank 1°

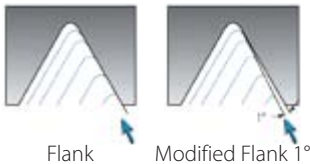

Toolholders for Round Inserts (DIN 20400)

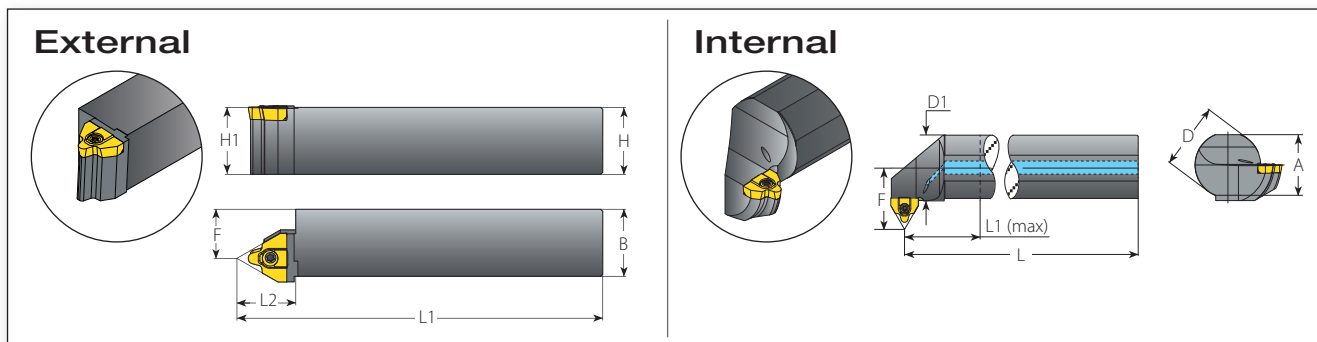

External

Insert	Ordering Code	Dimensions				Thread Diameter Range (Min.-Max.)	
		RH	H=B=H1	F	L1	L2	
5MGER 10.0RD20400...	NL25-5MG 10RD	25	16.5	155			
	NL32-5MG 10RD	32	23.5	175	22		(RD132-170)x10
	NL40-5MG 10RD	40	31.5	205			
5MGER 12.0RD20400...	NL25-5MG 12RD	25	16.5	155			
	NL32-5MG 12RD	32	23.5	175	22		(RD180-224)x12
	NL40-5MG 12RD	40	31.5	205			
5MGER 16.0RD20400...	NL25-5MG 16RD	25	16.5	155			
	NL32-5MG 16RD	32	23.5	175	22		(RD236-300)x16
	NL40-5MG 16RD	40	31.5	205			

Internal

Insert	Ordering Code	Dimensions						Min. Bore dia.	Thread Diameter Range (Min.-Max.)		
		RH	A	L	L1 (max)	D	D1		F	mm	Short Chip Material
5MGIR 10.0RD20400...	NVRC40-5MG 10RD	36	232.5	100	40	39.7	41.5				
	NVRC50-5MG 10RD	46	257.5	125	50	49.7	46.5	122	(RD132-170)x10	(RD132-170)x10	
	NVRC60-5MG 10RD	57	282.5	150	60	59.7	51.5				
5MGIR 12.0RD20400...	NVRC40-5MG 12RD	36	232.5	100	40	39.7	41.5				
	NVRC50-5MG 12RD	46	257.5	125	50	49.7	46.5	168	(RD180-224)x12	(RD180-224)x12	
	NVRC60-5MG 12RD	57	282.5	150	60	59.7	51.5				
5MGIR 16.0RD20400...	NVRC40-5MG 16RD	36	232.5	100	40	39.7	41.5				
	NVRC50-5MG 16RD	46	257.5	125	50	49.7	46.5	220	(RD236-300)x16	(RD236-300)x16	
	NVRC60-5MG 16RD	57	282.5	150	60	59.7	51.5				

Spare Parts for the above toolholders (external and internal): Insert Screw - S5MG

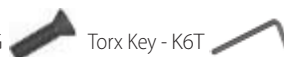

Torx Key - K6T

Trapez Inserts

External / Internal

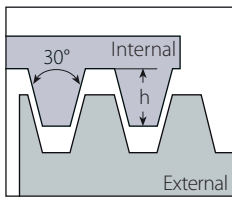

Defined by: DIN 103
Tolerance class: 7e/7H

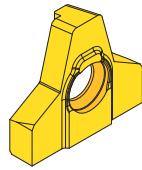

Internal

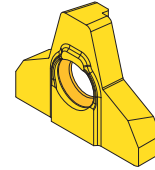
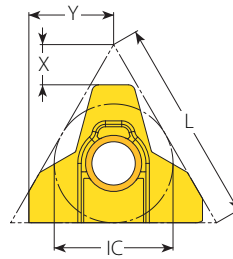

External

External

	Insert size		Pitch	Ordering Code	Dimensions mm			Number of Passes	
	IC	L mm	mm	RH	h min	X	Y	0.07mm–Min. Depth of Cut (On radius)	0.15mm–Max. Depth of Cut (On radius)
	5/8" MG	27	12.0	5MGER 12.0TR...	6.5	5.38	11.3	94	44
			14.0	5MGER 14.0TR...	8.0	4.38		115	54
			16.0	5MGER 16.0TR...	9.0	5.38		129	60
			18.0	5MGER 18.0TR...	10.0	5.38		143	67
			20.0	5MGER 20.0TR...	11.0	7.38		158	74
			24.0	5MGER 24.0TR...	13.0	7.38		186	87

Internal

	Insert size		Pitch	Ordering Code	Dimensions mm			Number of Passes	
	IC	L mm	mm	RH	h min	X	Y	0.07mm–Min. Depth of Cut (On radius)	0.15mm–Max. Depth of Cut (On radius)
	5/8" MG	27	12.0	5MGIR 12.0TR...	6.5	5.38	10.4	96	45
			14.0	5MGIR 14.0TR...	8.0	4.38		118	55
			16.0	5MGIR 16.0TR...	9.0	5.38		131	61
			18.0	5MGIR 18.0TR...	10.0	5.38		145	68
			20.0	5MGIR 20.0TR...	11.0	7.38		160	75
			24.0	5MGIR 24.0TR...	13.0	7.38		188	88

Recommended thread infeed method for Mega Line: Flank or Modified Flank 1°

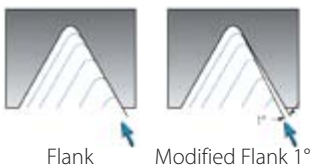

Toolholders for Trapez Inserts

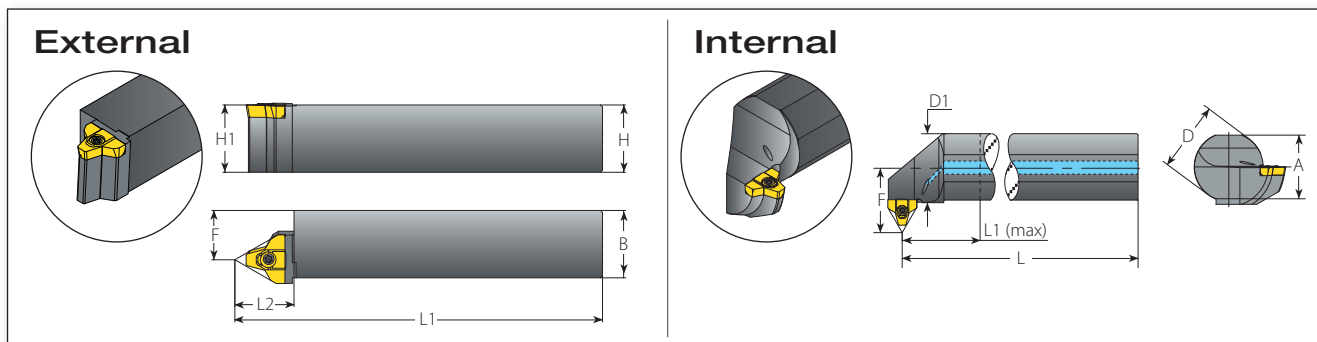

External

Insert	Ordering Code		Dimensions			Thread Diameter Range (Min.-Max.)	
	RH	H=B=H1	F	L1	L2		
5MGER 12.0TR...	NL25-5MG 12TR	25	16.5	155			
	NL32-5MG 12TR	32	23.5	175	22		(TR44-300)x12
	NL40-5MG 12TR	40	31.5	205			
5MGER 14.0TR...	NL25-5MG 14TR	25	16.5	155			
	NL32-5MG 14TR	32	23.5	175	22		(TR55-145)x14
	NL40-5MG 14TR	40	31.5	205			
5MGER 16.0TR...	NL25-5MG 16TR	25	16.5	155			
	NL32-5MG 16TR	32	23.5	175	22		(TR65-175)x16
	NL40-5MG 16TR	40	31.5	205			
5MGER 18.0TR...	NL25-5MG 18TR	25	16.5	155			
	NL32-5MG 18TR	32	23.5	175	22		(TR85-200)x18
	NL40-5MG 18TR	40	31.5	205			
5MGER 20.0TR...	NL25-5MG 20TR	25	16.5	155			
	NL32-5MG 20TR	32	23.5	175	22		(TR100-230)x20
	NL40-5MG 20TR	40	31.5	205			
5MGER 24.0TR...	NL25-5MG 24TR	25	16.5	155			
	NL32-5MG 24TR	32	23.5	175	22		(TR135-300)x24
	NL40-5MG 24TR	40	31.5	205			

Internal

Insert	Ordering Code		Dimensions					Min. Bore dia. mm	Thread Diameter Range (Min.-Max.)	
	RH	A	L	L1 (max)	D	D1	F		Short Chip Material	Long Chip Material
5MGIR 12.0TR...	NVRC40-5MG 12TR	36	232.5	100	40	39.7	41.5	73	(TR85-300)x12	(TR85-300)x12
	NVRC50-5MG 12TR	46	257.5	125	50	49.7	46.5	73	(TR85-300)x12	(TR95-300)x12
	NVRC60-5MG 12TR	57	282.5	150	60	59.7	51.5	83	(TR95-300)x12	(TR105-300)x12
5MGIR 14.0TR...	NVRC40-5MG 14TR	36	232.5	100	40	39.7	41.5	101	(TR115-145)x14	(TR115-145)x14
	NVRC50-5MG 14TR	46	257.5	125	50	49.7	46.5	101	(TR115-145)x14	(TR115-145)x14
	NVRC60-5MG 14TR	57	282.5	150	60	59.7	51.5	101	(TR115-145)x14	(TR115-145)x14
5MGIR 16.0TR...	NVRC40-5MG 16TR	36	232.5	100	40	39.7	41.5	64	(TR80-175)x16	(TR150-175)x16
	NVRC50-5MG 16TR	46	257.5	125	50	49.7	46.5	134	(TR150-175)x16	(TR150-175)x16
	NVRC60-5MG 16TR	57	282.5	150	60	59.7	51.5	134	(TR150-175)x16	(TR150-175)x16
5MGIR 18.0TR...	NVRC40-5MG 18TR	36	232.5	100	40	39.7	41.5	72	(TR85-200)x18	(TR90-200)x18
	NVRC50-5MG 18TR	46	257.5	125	50	49.7	46.5	72	(TR90-200)x18	(TR180-200)x18
	NVRC60-5MG 18TR	57	282.5	150	60	59.7	51.5	162	(TR180-200)x18	(TR180-200)x18
5MGIR 20.0TR...	NVRC40-5MG 20TR	36	232.5	100	40	39.7	41.5	80	(TR100-230)x20	(TR100-230)x20
	NVRC50-5MG 20TR	46	257.5	125	50	49.7	46.5	80	(TR100-230)x20	(TR100-230)x20
	NVRC60-5MG 20TR	57	282.5	150	60	59.7	51.5	85	(TR105-230)x20	(TR210-230)x20
5MGIR 24.0TR...	NVRC40-5MG 24TR	36	232.5	100	40	39.7	41.5	111	(TR135-300)x24	(TR135-300)x24
	NVRC50-5MG 24TR	46	257.5	125	50	49.7	46.5	111	(TR135-300)x24	(TR135-300)x24
	NVRC60-5MG 24TR	57	282.5	150	60	59.7	51.5	111	(TR135-300)x24	(TR135-300)x24

Spare Parts for the above toolholders (external and internal): Insert Screw - S5MG

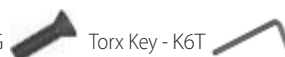

Torx Key - K6T

ACME Inserts

External / Internal

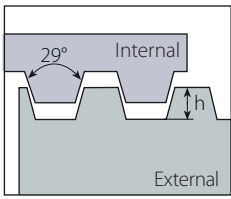

Defined by: ANSI B1.8:1988
Tolerance class: 2G

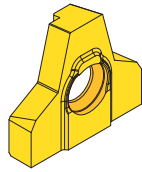

Internal

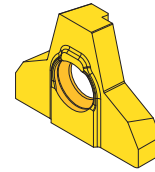
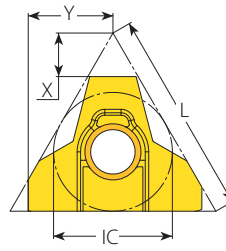

External

External

	Insert size		Pitch	Ordering Code	Dimensions mm			Number of Passes	
	IC	L mm	tpi	RH	h min	X	Y	0.07mm–Min. Depth of Cut (On radius)	0.15mm–Max. Depth of Cut (On radius)
	5/8" MG	27	2	5MGER 2ACME...	6.60	4.81	11.3	95	44
			1 1/2	5MGER 1-1/2ACME...	8.72	5.81		125	58
			1 1/3	5MGER 1-1/3ACME...	9.78	6.81		140	65
			1	5MGER 1ACME...	12.95	8.31		186	87

Internal

	Insert size		Pitch	Ordering Code	Dimensions mm			Number of Passes	
	IC	L mm	tpi	RH	h min	X	Y	0.07mm–Min. Depth of Cut (On radius)	0.15mm–Max. Depth of Cut (On radius)
	5/8" MG	27	2	5MGIR 2ACME...	6.54	4.81	10.4	94	44
			1 1/2	5MGIR 1-1/2ACME...	8.55	5.81		124	58
			1 1/3	5MGIR 1-1/3ACME...	9.56	6.81		139	65
			1	5MGIR 1ACME...	12.57	8.31		184	86

Recommended thread infeed method for Mega Line: Flank or Modified Flank 1°

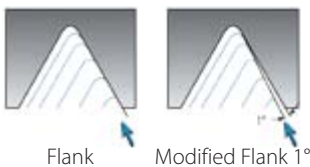

Toolholders for ACME Inserts

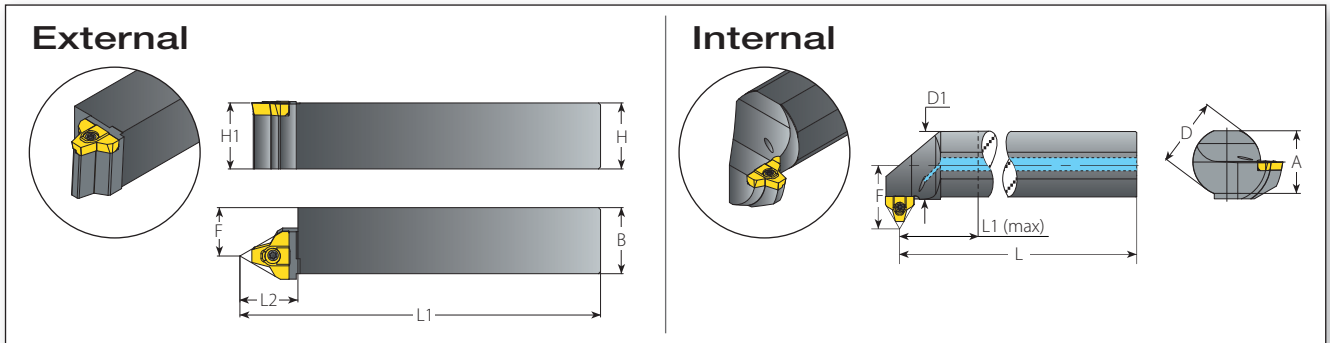

External

Insert	Ordering Code		Dimensions			Thread Diameter Range (Min.-Max.)
	RH	H=B=H1	F	L1	L2	
5MGER 2ACME...	NL25-5MG 2ACME	25	16.5	155		(3"-5")-2ACME
	NL32-5MG 2ACME	32	23.5	175	22	
	NL40-5MG 2ACME	40	31.5	205		
5MGER 1-1/2ACME...	NL25-5MG 1-1/2ACME	25	16.5	155		(3"-5")-1 1/2ACME
	NL32-5MG 1-1/2ACME	32	23.5	175	22	
	NL40-5MG 1-1/2ACME	40	31.5	205		
5MGER 1-1/3ACME...	NL25-5MG 1-1/3ACME	25	16.5	155		(3"-5")-1 1/3ACME
	NL32-5MG 1-1/3ACME	32	23.5	175	22	
	NL40-5MG 1-1/3ACME	40	31.5	205		
5MGER 1ACME...	NL25-5MG 1ACME	25	16.5	155		(3.5"-5")-1ACME
	NL32-5MG 1ACME	32	23.5	175	22	
	NL40-5MG 1ACME	40	31.5	205		

Internal

Insert	Ordering Code	Dimensions						Min. Bore dia.	Thread Diameter Range (Min.-Max.)	
		A	L	L1 (max)	D	D1	F		mm	Short Chip Material
5MGIR 2ACME...	NVRC40-5MG 2ACME	36	232.5	100	40	39.7	41.5	63.5	(3"-5")-2ACME	(3.5"-5")-2ACME
	NVRC50-5MG 2ACME	46	257.5	125	50	49.7	46.5	76.2	(3.5"-5")-2ACME	(4"-5")-2ACME
	NVRC60-5MG 2ACME	57	282.5	150	60	59.7	51.5	88.9	(4"-5")-2ACME	(4.5"-5")-2ACME
5MGIR 1-1/2ACME...	NVRC40-5MG 1-1/2ACME	36	232.5	100	40	39.7	41.5	59.3	(3"-5")-1 1/2ACME	(3.5"-5")-1 1/2ACME
	NVRC50-5MG 1-1/2ACME	46	257.5	125	50	49.7	46.5	72.0	(3.5"-5")-1 1/2ACME	(4"-5")-1 1/2ACME
	NVRC60-5MG 1-1/2ACME	57	282.5	150	60	59.7	51.5	84.7	(4"-5")-1 1/2ACME	(4.5"-5")-1 1/2ACME
5MGIR 1-1/3ACME...	NVRC40-5MG 1-1/3ACME	36	232.5	100	40	39.7	41.5	57.2	(3"-5")-1 1/3ACME	(3.5"-5")-1 1/3ACME
	NVRC50-5MG 1-1/3ACME	46	257.5	125	50	49.7	46.5	69.9	(3.5"-5")-1 1/3ACME	(4.0"-5")-1 1/3ACME
	NVRC60-5MG 1-1/3ACME	57	282.5	150	60	59.7	51.5	82.6	(4.0"-5")-1 1/3ACME	(4.5"-5")-1 1/3ACME
5MGIR 1ACME...	NVRC40-5MG 1ACME	36	232.5	100	40	39.7	41.5	63.5	(3.5"-5")-1ACME	(4"-5")-1ACME
	NVRC50-5MG 1ACME	46	257.5	125	50	49.7	46.5	76.2	(4"-5")-1ACME	(4.5"-5")-1ACME
	NVRC60-5MG 1ACME	57	282.5	150	60	59.7	51.5	76.2	(4"-5")-1ACME	(4.5"-5")-1ACME

Spare Parts for the above toolholders (external and internal): Insert Screw - S5MG

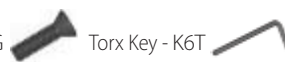

Torx Key - K6T

Stub ACME Inserts

External / Internal

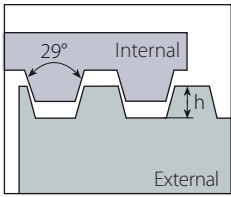

Defined by: ANSI B1.8:1988
Tolerance class: 2G

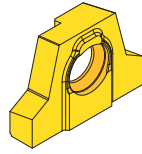

Internal

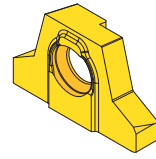
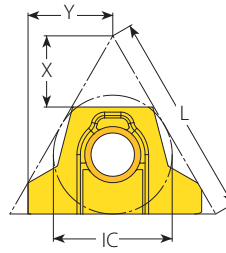

External

External



Insert size		Pitch	Ordering Code	Dimensions mm			Number of Passes	
IC	L mm	tpi	RH	h min	X	Y	0.07mm–Min. Depth of Cut (On radius)	0.15mm–Max. Depth of Cut (On radius)
5/8" MG	27	1	5MGER 1STACME...	7.87	9.51	11.3	113	53

Internal



Insert size		Pitch	Ordering Code	Dimensions mm			Number of Passes	
IC	L mm	tpi	RH	h min	X	Y	0.07mm–Min. Depth of Cut (On radius)	0.15mm–Max. Depth of Cut (On radius)
5/8" MG	27	1	5MGIR 1STACME...	7.82	9.51	10.4	113	53

Recommended thread infeed method for Mega Line: Flank or Modified Flank 1°

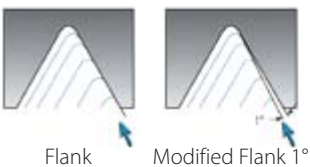

Toolholders for Stub ACME Inserts

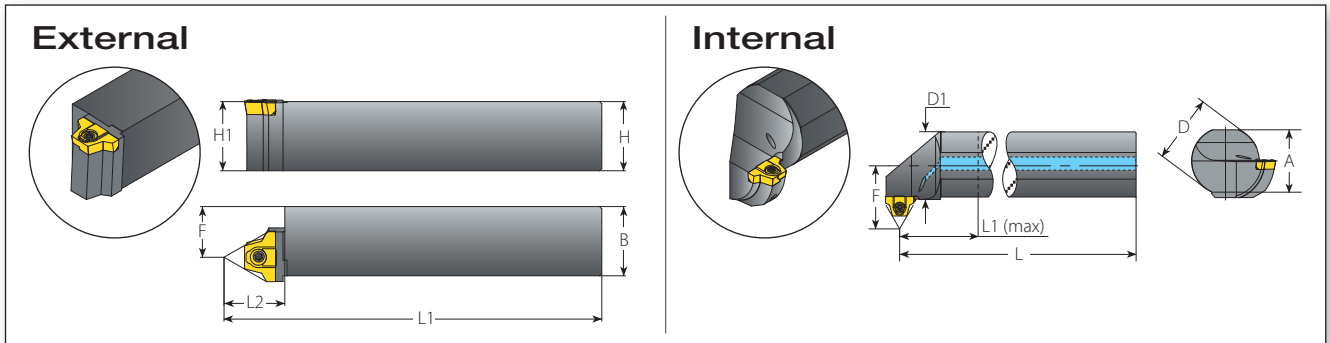

External

Insert	Ordering Code		Dimensions			Thread Diameter Range (Min.-Max.)
	RH	H=B=H1	F	L1	L2	
5MGER 1STACME...	NL25-5MG 1STACME	25	16.5	155		(3.5"-5")-1STACME
	NL32-5MG 1STACME	32	23.5	175	22	
	NL40-5MG 1STACME	40	31.5	205		

Internal

Insert	Ordering Code	Dimensions						Min. Bore dia.	Thread Diameter Range (Min.-Max.)	
		RH	A	L	L1 (max)	D	D1		F	mm
5MGIR 1STACME...	NVRC40-5MG 1STACME	36	232.5	100	40	39.7	41.5	73.7	(3.5"-5")-1STACME	(3.5"-5")-1STACME
	NVRC50-5MG 1STACME	46	257.5	125	50	49.7	46.5	73.7	(3.5"-5")-1STACME	(4.0"-5")-1STACME
	NVRC60-5MG 1STACME	57	282.5	150	60	59.7	51.5	86.4	(4.0"-5")-1STACME	(4.5"-5")-1STACME

Spare Parts for the above toolholders (external and internal): Insert Screw - S5MG



Torx Key - K6T

American Buttress Inserts

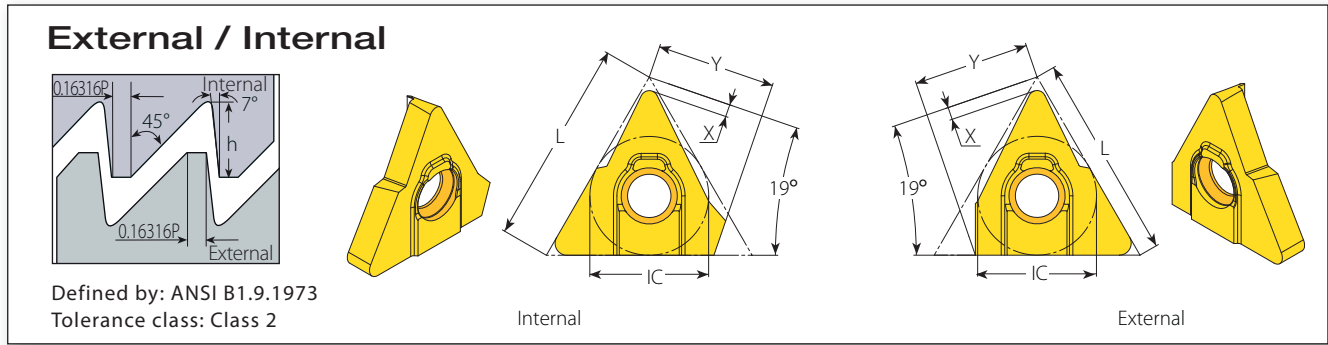

External



Insert size	Pitch	Ordering Code	Dimensions mm			Number of Passes		
			IC	L mm	tpi	RH	h min	X
5/8" MG	27	2	5MGER 2ABUT	8.42	1.58	15.55	120	56
		1.5	5MGER 1.5ABUT	11.22	1.64		160	75

Internal



Insert size	Pitch	Ordering Code	Dimensions mm			Number of Passes		
			IC	L mm	tpi	RH	h min	X
5/8" MG	27	2	5MGIR 2ABUT	8.94	1.58	15.9	128	60
		1.5	5MGIR 1.5ABUT	11.92	1.64		170	79

Note: American Buttress inserts are non-stock items

Recommended thread infeed method for Mega Line: Flank or Modified Flank 1°

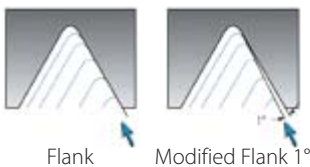

Toolholders for American Buttress Inserts

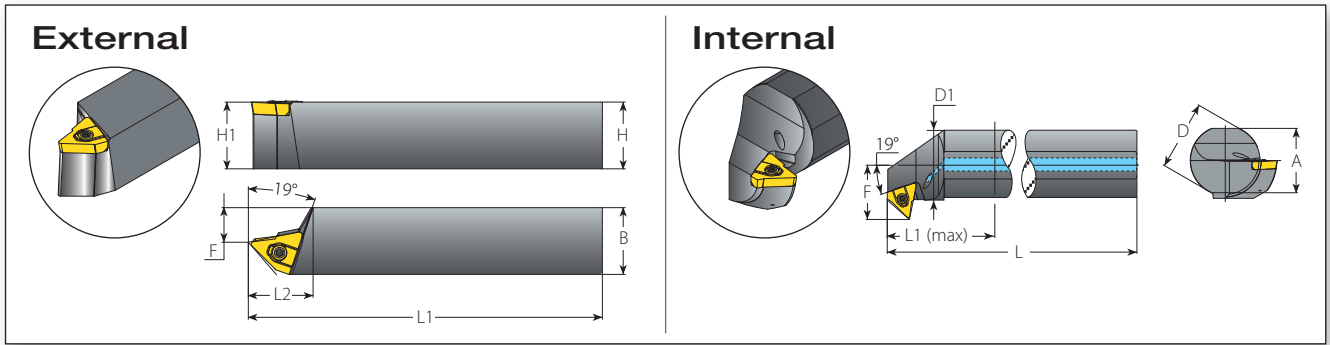

External

Insert	Ordering Code		Dimensions			Thread Diameter Range (Min.-Max.)
	RH	H=B=H1	F	L1	L2	
5MGER 2ABUT...	NL25-5MG 2ABUT	25	9.5	150		(7"-24")-2BUTT
	NL32-5MG 2ABUT	32	16.5	170	31	
	NL40-5MG 2ABUT	40	24.5	200		
5MGER 1.5ABUT...	NL25-5MG 1.5ABUT	25	9.5	150		(11"-24")-1.5BUTT
	NL32-5MG 1.5ABUT	32	16.5	170	31	
	NL40-5MG 1.5ABUT	40	24.5	200		

Internal

Insert	Ordering Code		Dimensions					Min. Bore dia.	Thread Diameter Range (Min.-Max.)	
	RH	A	L	L1 (max)	D	D1	F		mm	Short Chip Material
5MGIR 2ABUT...	NVRC40-5MG 2ABUT	36	230.5	100	40	39.7	35.0	162.6	(7"-16")-2BUTT	(7"-16")-2BUTT
	NVRC50-5MG 2ABUT	46	255.5	125	50	49.7	39.5			
	NVRC60-5MG 2ABUT	57	280.5	150	60	59.7	44.0			
5MGIR 1.5ABUT...	NVRC40-5MG 1.5ABUT	36	230.5	100	40	39.7	35.0	259.1	(11"-22")-1.5BUTT	(11"-22")-1.5BUTT
	NVRC50-5MG 1.5ABUT	46	255.5	125	50	49.7	39.5			
	NVRC60-5MG 1.5ABUT	57	280.5	150	60	59.7	44.0			

Note: American Buttress toolholders are non-stock items

Spare Parts for the above toolholders (external and internal): Insert Screw - S5MG



Torx Key - K6T



Metric Buttress (Sägengewinde) Inserts

External / Internal

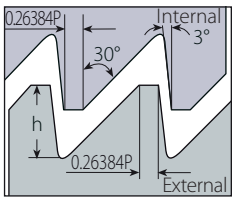

Defined by: DIN 513
Tolerance class: Medium Class

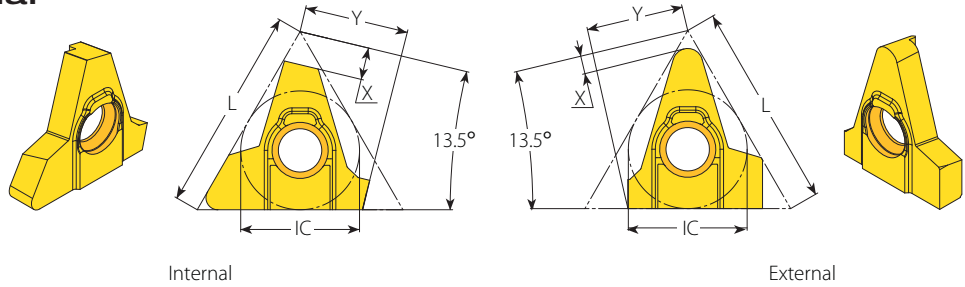

External

	Insert size		Pitch	Ordering Code	Dimensions mm			Number of Passes	
	IC	L mm	mm	RH	h min	X	Y	0.07mm–Min. Depth of Cut (On radius)	0.15mm–Max. Depth of Cut (On radius)
	5/8" MG	27	10.0	5MGER 10.0SAGE...	8.68	1.57	13.3	124	58
			12.0	5MGER 12.0SAGE...	10.41	1.81		149	69
			14.0	5MGER 14.0SAGE...	12.15	2.05		174	81
			16.0	5MGER 16.0SAGE...	13.88	3.27		198	93
			20.0	5MGER 20.0SAGE...	17.36	2.56		248	116

Internal

	Insert size		Pitch	Ordering Code	Dimensions mm			Number of Passes	
	IC	L mm	mm	RH	h min	X	Y	0.07mm–Min. Depth of Cut (On radius)	0.15mm–Max. Depth of Cut (On radius)
	5/8" MG	27	10.0	5MGIR 10.0SAGE...	7.21	2.86	13.7	103	48
			12.0	5MGIR 12.0SAGE...	8.67	3.34		124	58
			14.0	5MGIR 14.0SAGE...	10.12	3.83		145	67
			16.0	5MGIR 16.0SAGE...	11.58	4.30		165	77
			20.0	5MGIR 20.0SAGE...	14.50	5.16		207	97

Note: Metric Buttress inserts are non-stock items

Recommended thread infeed method for Mega Line: Flank or Modified Flank 1°

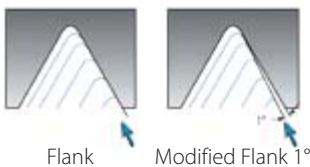

Toolholders for Metric Buttress Inserts (Sägengewinde)

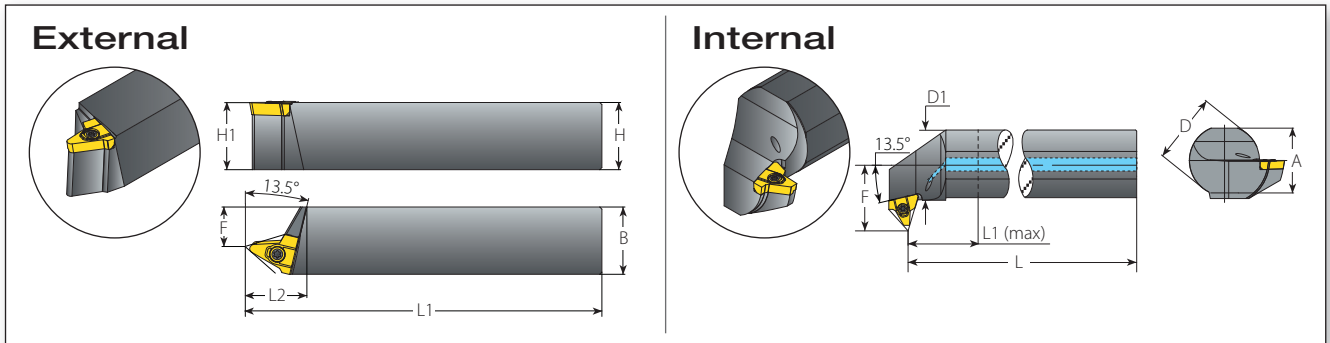

External

Insert	Ordering Code	Dimensions				Thread Diameter Range (Min.-Max.)
		RH	H=B=H1	F	L1	
5MGER 10.0SAGE...	NL25-5MG 10SAGE		25	11.8	150	
	NL32-5MG 10SAGE		32	18.8	170	30
	NL40-5MG 10SAGE		40	26.8	200	
5MGER 12.0SAGE...	NL25-5MG 12SAGE		25	11.8	150	
	NL32-5MG 12SAGE		32	18.8	170	30
	NL40-5MG 12SAGE		40	26.8	200	
5MGER 14.0SAGE...	NL25-5MG 14SAGE		25	11.8	150	
	NL32-5MG 14SAGE		32	18.8	170	30
	NL40-5MG 14SAGE		40	26.8	200	
5MGER 16.0SAGE...	NL25-5MG 16SAGE		25	11.8	150	
	NL32-5MG 16SAGE		32	18.8	170	30
	NL40-5MG 16SAGE		40	26.8	200	
5MGER 20.0SAGE...	NL25-5MG 20SAGE		25	11.8	150	
	NL32-5MG 20SAGE		32	18.8	170	30
	NL40-5MG 20SAGE		40	26.8	200	

Internal

Insert	Ordering Code	Dimensions						Min. Bore dia.	Thread Diameter Range (Min.-Max.)		
		RH	A	L	L1 (max)	D	D1		F	mm	Short Chip Material
5MGIR 10.0SAGE...	NVRC40-5MG 10SAGE		36	230.5	100	40	39.7	29.0	50	(S65-80)x10	(S75-80)x10
	NVRC40-5MG 12SAGE		36	230.5	100	40	39.7	41.5	67	(S85-400)x12	(S90-400)x12
5MGIR 12.0SAGE...	NVRC50-5MG 12SAGE		46	255.5	125	50	49.7	46.5	72	(S90-400)x12	(S105-400)x12
	NVRC60-5MG 12SAGE		57	280.5	150	60	59.7	51.5	82	(S100-400)x12	(S250-400)x12
5MGIR 14.0SAGE...	NVRC40-5MG 14SAGE		36	230.5	100	40	39.7	41.5	94	(S115-145)x14	(S115-145)x14
	NVRC50-5MG 14SAGE		46	255.5	125	50	49.7	46.5	94	(S115-145)x14	(S115-145)x14
	NVRC60-5MG 14SAGE		57	280.5	150	60	59.7	51.5	94	(S115-145)x14	(S120-145)x14
5MGIR 16.0SAGE...	NVRC40-5MG 16SAGE		36	230.5	100	40	39.7	41.5	126	(S150-175)x16	(S150-175)x16
	NVRC50-5MG 16SAGE		46	255.5	125	50	49.7	46.5	126	(S150-175)x16	(S150-175)x16
	NVRC60-5MG 16SAGE		57	280.5	150	60	59.7	51.5	126	(S150-175)x16	(S150-175)x16
5MGIR 20.0SAGE...	NVRC40-5MG 20SAGE		36	230.5	100	40	39.7	41.5	75	(S105-230)x20	(S105-230)x20
	NVRC50-5MG 20SAGE		46	255.5	125	50	49.7	46.5	75	(S105-230)x20	(S210-230)x20
	NVRC60-5MG 20SAGE		57	280.5	150	60	59.7	51.5	80	(S110-230)x20	(S210-230)x20

Note: Metric Buttress toolholders are non-stock items

Spare Parts for the above toolholders (external and internal): Insert Screw - S5MG

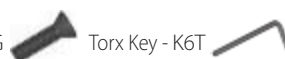

Torx Key - K6T

Recommended Grades and Cutting Speeds Vc [m/min]

Material Group	Vardex No.	Material	Hardness Brinell HB	Vc [m/min]	
				Coated	
				VKX	
P Steel	1	Unalloyed steel	Low carbon (C=0.1-0.25%)	125	115-190
	2		Medium carbon (C=0.25-0.55%)	150	100-175
	3		High carbon (C=0.55-0.85%)	170	90-165
	4	Low alloy steel (alloying elements ≤5%)	Non hardened	180	100-180
	5		Hardened	275	75-140
	6		Hardened	350	70-135
	7	High alloy steel (alloying elements >5%)	Annealed	200	80-120
	8		Hardened	325	50-100
	9	Cast steel	Low alloy (alloying elements <5%)	200	70-130
	10		High alloy (alloying elements >5%)	225	60-120
M Stainless Steel	11	Stainless steel Ferritic	Non hardened	200	70-130
	12		Hardened	330	60-115
	13	Stainless steel Austenitic	Austenitic	180	90-140
	14		Super Austenitic	200	40-110
	15	Stainless steel Cast Ferritic	Non hardened	200	90-120
	16		Hardened	330	65-110
	17	Stainless steel Cast austenitic	Austenitic	200	85-110
	18		Hardened	330	60-100
K Cast Iron	28	Malleable Cast iron	Ferritic (short chips)	130	60-70
	29		Pearlitic (long chips)	230	60-145
	30	Grey Cast iron	Low tensile strength	180	70-130
	31		High tensile strength	260	60-115
	32	Nodular SG iron	Ferritic	160	125-160
	33		Pearlitic	260	90-120
N(K) Non-Ferrous Metals	34	Aluminium alloys Wrought	Non aging	60	100-365
	35		Aged	100	80-220
	36	Aluminium alloys	Cast	75	200-400
	37		Cast & aged	90	200-280
	38	Aluminium alloys	Cast Si 13-22%	130	60-180
	39	Copper and copper alloys	Brass	90	80-225
	40		Bronze and non leaded copper	100	80-255
S(M) Heat Resistant Material	19	High temperature alloys	Annealed (Iron based)	200	45-60
	20		Aged (Iron based)	280	30-50
	21		Annealed (Nickel or Cobalt based)	250	20-30
	22		Aged (Nickel or Cobalt based)	350	15-25
	23	Titanium alloys	Pure 99.5 Ti	400Rm	140-170
	24		α+β alloys	1050Rm	50-70
H(K) Hardened Material	25	Extra hard steel	Hardened & tempered	45-50HRc	
	26			51-55HRc	

Note: For Number of Passes, refer to the insert tables.

Grades

Grade	Application	Sample
VKX	Superior general purpose grade, excellent for machining steels and stainless steels. TiN coated.	



VARGUS GENIUS™

Tool Selector and CNC Program Generator



The most popular and advanced thread turning and thread milling software on the market today.

Now available in 2 versions at www.vargus.com:

- Online Version
 - Online interactive software
 - For the most popular web browsers
 - Most updated version always online
- Desktop (Downloadable) Version
 - Standalone software application
 - MS Windows OS-based program
 - Automatic updates



MEGALINE
For Extra Large Pitches



VARDEX
Advanced Threading Solutions



Visit VARGUS