

Your technology partner for cost-effective machining

OptiMill[®] - Composite-Speed-Plus

OptiMill®-Composite-Speed-Plus

A new dimension of process reliability

The OptiMill-Composite-Speed-Plus features a new diamond coating developed by MAPAL with even distribution and higher coating thickness. The bigger core diameter increases fracture strength by 50 percent. The improved groove profile ensures efficient, reliable removal of dust and heat even when machining large volumes. The cutting wedge has been specially optimised to meet the requirements of brittle workpiece material. The special cutting-edge serration causes double compression so that fibre fraying on the workpiece edges of the upper and lower sides are reliably separated.

This allows the OptiMill-Composite-Speed-Plus to attain a new dimension in process reliability. Compared to the OptiMill-Composite-Speed, 20 percent longer tool life is achieved.

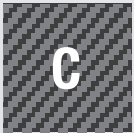

Composite materials



Graphites, thermosets

PROCESS RELIABILITY



Increased fracture strength

NEW



OptiMill®-Composite-Speed-Plus

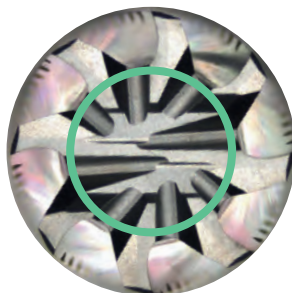

OptiMill®-Composite-Speed

- Bigger core diameter
- New dimensions with adjusted cutting length in accordance with DIN6527

MAPAL coating

Coating thickness distribution

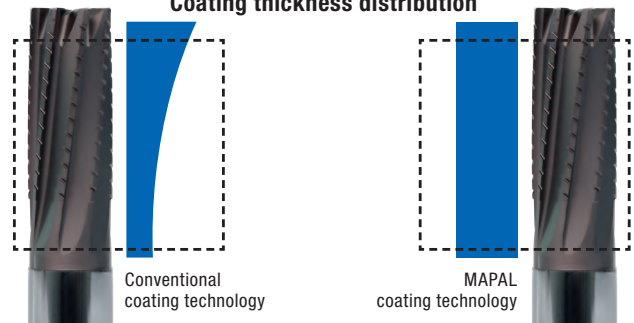

- Optimized distribution of coating thickness
- Increased diamond coating for maximum tool life

WIDE RANGE OF APPLICATIONS

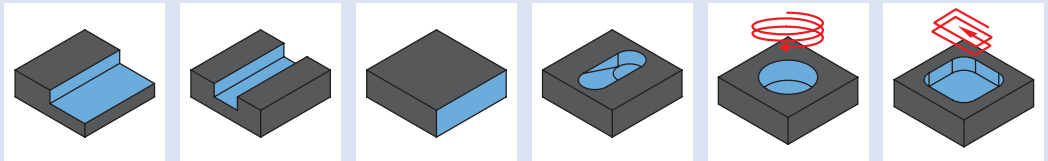

QUALITY

Excellent cutting quality

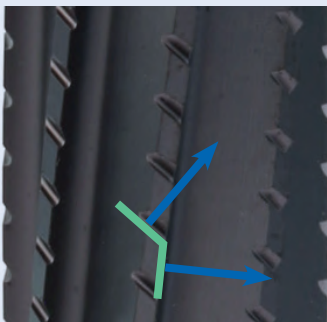

- Special cutting-edge serration causes double compression
- Reliable separation of fibre fraying on workpiece edges
- Extremely sharp cutting edges

WEAR AND TEAR

Maximum tool life

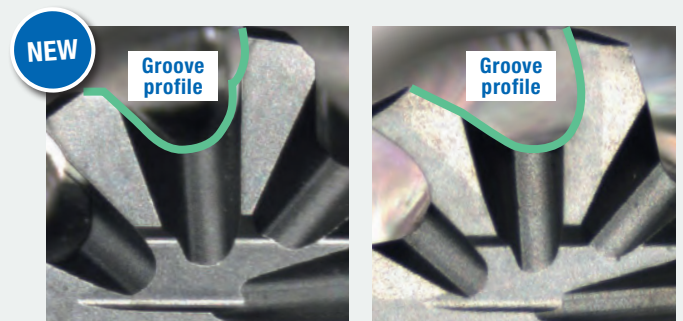

OptiMill®-Composite-Speed-Plus

OptiMill®-Composite-Speed

- High cutting stability due to reinforced cutting wedge
- Optimised groove profile and double point thinning for better dust removal
- Improved coating adhesion properties

OptiMill®-Composite-Speed-Plus

Uncoated



Performance Line:

High-performance tools, broad field of application, greater productivity in series manufacturing

NEW TOOL DESIGN FOR MORE PRODUCTIVITY

Compared to previous router tools, the OptiMill-Composite-Speed-Plus markedly improves quiet running and increases tool life.

NEW

Increased productivity

+30%

Pushing cutting edge

Pulling cutting edge

- Tool life
- Quiet running
- Productivity
- Cutting quality

OptiMill-Composite MT | Router tools

OptiMill-Composite-Speed-Plus, uncoated

COMPARISON TOOL LIFE [m]

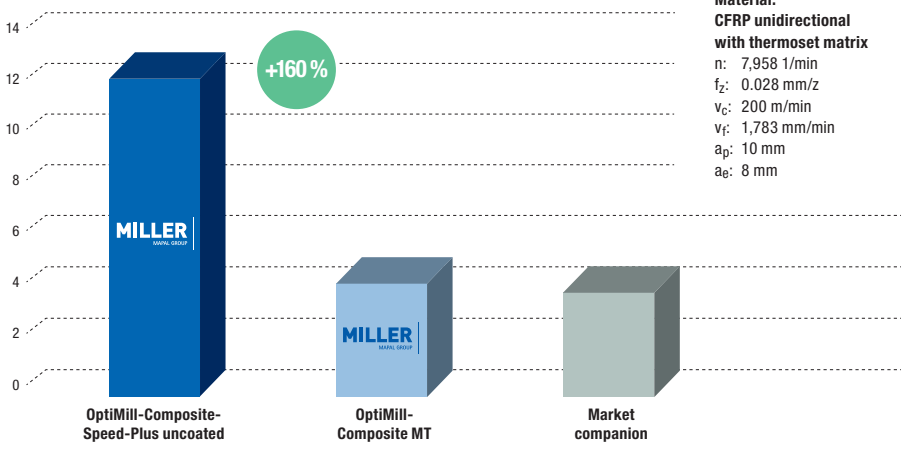

AT A GLANCE

- First choice in unfavourable process conditions
- Extremely sharp cutting edge for optimum cutting quality
- Ideal for workpiece material with low abrasiveness

OptiMill®-Composite-Speed-Plus

Coated



Expert Line:
Specialist tools for selected applications,
maximum precision and productivity

FURTHER DEVELOPMENT REDUCES AXIAL FORCES

Axial forces for the OptiMill-Composite-Speed-Plus are reduced by 40 percent compared to the OptiMill-Composite-Speed. A neutral series is not required for this reason.



COMPARISON TOOL LIFE [m]

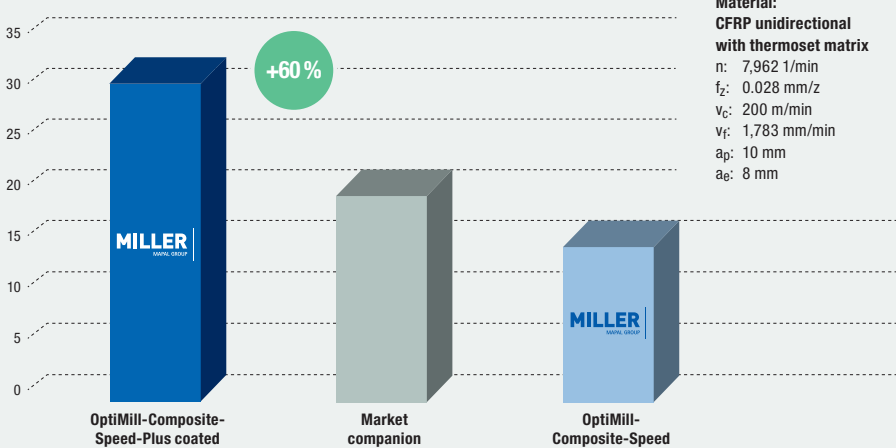

Material:
CFRP unidirectional
with thermoset matrix

n: 7,962 1/min
f_z: 0.028 mm/z
v_c: 200 m/min
v_f: 1,783 mm/min
a_p: 10 mm
a_e: 8 mm

AT A GLANCE

- First choice in good process conditions
- Even MAPAL uniform diamond coating thickness distribution for increased process reliability
- Increased coating thickness for maximum tool life
- Highest productivity

OptiMill®-Composite-Speed-Plus

Shoulder milling cutter, design with pulling cutting edge
M7248P

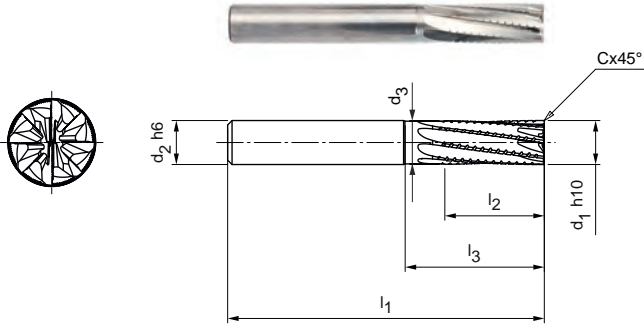

N	1.1	1.2	1.3	1.4	2.1	2.2	2.3	3.1	3.2	4.1	4.2	4.3	C	1.1	1.2	1.3	2.1	3.1	4.1	4.2	5.1	5.2	5.3
---	-----	-----	-----	-----	-----	-----	-----	-----	-----	-----	-----	-----	---	-----	-----	-----	-----	-----	-----	-----	-----	-----	-----

Design:
 Diameter of milling cutter: 4.00 - 20.00 mm
 Coating: Uncoated
 Number of cutting edges: 8
 Helix angle: 8°
 Special features: Without coating, extremely sharp cutting edge

Application:
 Roughing and finishing of CFRP in one machining step. Pulling cutting edge for better removal of the chips/dust (e.g. on milling pockets and slots). Particularly suitable for difficult to machine surface layers (e.g. UD or copper mesh) to prevent delamination on the lower edge of the part.

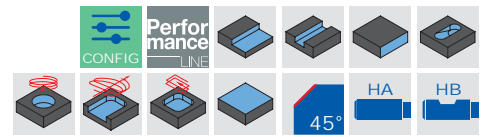

Preferred series available from stock

Dimensions							z	Specification	Order no.
d1 h10	d2 h6	d3	l1	l2	l3	Cx45°			
4,00	6	3,90	57	11	-	0,08	8	M7248P-0400AU-C0008	31237383
5,00	6	4,90	57	13	-	0,10	8	M7248P-0500AU-C0010	31237384
6,00	6	5,80	57	13	19	0,12	8	M7248P-0600AU-C0012	31237385
6,00	6	5,80	65	21	27	0,12	8	M7248P-0600AU-C0012	31237386
8,00	8	7,80	63	19	25	0,16	8	M7248P-0800AU-C0016	31237387
8,00	8	7,80	70	22	32	0,16	8	M7248P-0800AU-C0016	31237388
10,00	10	9,70	72	22	30	0,20	8	M7248P-1000AU-C0020	31237389
12,00	12	11,60	83	26	36	0,24	8	M7248P-1200AU-C0024	31237390
16,00	16	15,50	92	32	42	0,32	8	M7248P-1600AU-C0032	31237391

Available on request

20,00	20	19,40	104	38	52	0,40	8	M7248P-2000AU-C0040	31237392
-------	----	-------	-----	----	----	------	---	---------------------	----------

Configurable features



Shank form:
Shank form: HB



Specification:
M7248P-1200[shank form]-C0024

Example:
M7248P-1200BU-C0024

Shank form HB

Dimensions in mm.
 For cutting data recommendations, see end of chapter.
 Special designs and other coatings available upon request.

OptiMill®-Composite-Speed-Plus

Shoulder milling cutter, design with pushing cutting edge
M7258P

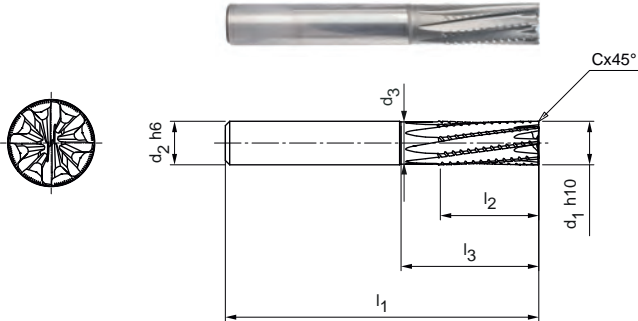

N	1.1	1.2	1.3	1.4	2.1	2.2	2.3	3.1	3.2	4.1	4.2	4.3	C	1.1	1.2	1.3	2.1	3.1	4.1	4.2	5.1	5.2	5.3
---	-----	-----	-----	-----	-----	-----	-----	-----	-----	-----	-----	-----	---	-----	-----	-----	-----	-----	-----	-----	-----	-----	-----

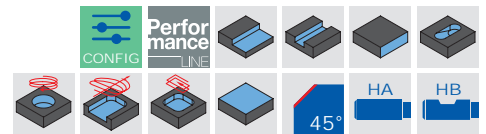

Design:
 Diameter of milling cutter: 4.00 - 20.00 mm
 Coating: Uncoated
 Number of cutting edges: 8
 Helix angle: -8 °
 Special features: Without coating, extremely sharp cutting edge

Application:
 Roughing and finishing of CFRP in one machining step. Pushing cutting edge, where the material is pressed onto the base (e.g. very suitable for vacuum clamping). Particularly suitable for difficult to machine surface layers (e.g. UD or copper mesh) to prevent delamination on the upper edge of the part.

Preferred series available from stock

Dimensions							z	Specification	Order no.
d1 h10	d2 h6	d3	l1	l2	l3	Cx45°			
4,00	6	3,90	57	11	-	0,08	8	M7258P-0400AU-C0008	31242565
5,00	6	4,90	57	13	-	0,10	8	M7258P-0500AU-C0010	31242566
6,00	6	5,80	57	13	19	0,12	8	M7258P-0600AU-C0012	31242567
6,00	6	5,80	65	21	27	0,12	8	M7258P-0600AU-C0012	31242568
8,00	8	7,80	63	19	25	0,16	8	M7258P-0800AU-C0016	31242569
8,00	8	7,80	70	22	32	0,16	8	M7258P-0800AU-C0016	31242580
10,00	10	9,70	72	22	30	0,20	8	M7258P-1000AU-C0020	31242581
12,00	12	11,60	83	26	36	0,24	8	M7258P-1200AU-C0024	31242582
16,00	16	15,50	92	32	42	0,32	8	M7258P-1600AU-C0032	31242583

Available on request

20,00	20	19,40	104	38	52	0,40	8	M7258P-2000AU-C0040	31242584
-------	----	-------	-----	----	----	------	---	---------------------	----------

Configurable features



Shank form:
Shank form: HB



Specification:
M7258P-1200[shank form]U-C0024

Example:
M7258P-1200BU-C0024

Shank form HB

Dimensions in mm.

For cutting data recommendations, see end of chapter.

Special designs and other coatings available upon request.

OptiMill®-Composite-Speed-Plus

Shoulder milling cutter, design with pulling cutting edge
M7228P, follow-up product of M7228

Design:
 Diameter of milling cutter: 4.00 - 20.00 mm
 Coating: Diamond-coated
 Number of cutting edges: 8
 Helix angle: 8°
 Special features: Diamond coating

Application:
 Roughing and finishing of CFRP in one machining step. Pulling cutting edge for better removal of the chips/dust (e.g. on milling pockets and slots). Particularly suitable for difficult to machine surface layers (e.g. UD or copper mesh) to prevent delamination on the lower edge of the part.

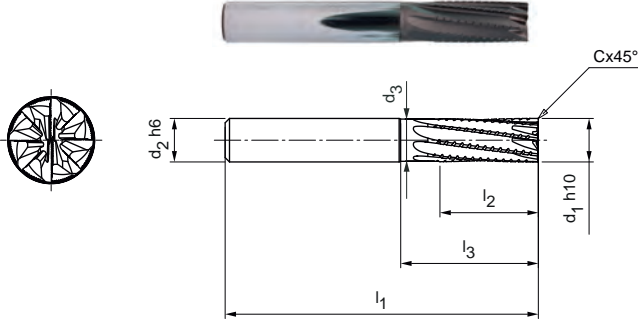

N	1.1	1.2	1.3	1.4	2.1	2.2	2.3	3.1	3.2	4.1	4.2	4.3	C	1.1	1.2	1.3	2.1	3.1	4.1	4.2	5.1	5.2	5.3	

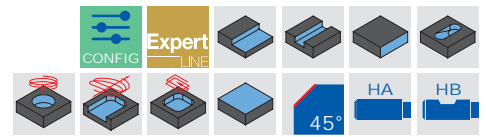

Preferred series available from stock

Dimensions							z	Specification	Order no.
d1 h10	d2 h6	d3	l1	l2	l3	Cx45°			
4,00	6	3,90	57	11	–	0,08	8	M7228P-0400AQ-C0008	31223317
5,00	6	4,90	57	13	–	0,10	8	M7228P-0500AQ-C0010	31223318
6,00	6	5,80	57	13	19	0,12	8	M7228P-0600AQ-C0012	31223319
6,00	6	5,80	65	21	27	0,12	8	M7228P-0600AQ-C0012	31223330
8,00	8	7,80	63	19	25	0,16	8	M7228P-0800AQ-C0016	31223331
8,00	8	7,80	70	22	32	0,16	8	M7228P-0800AQ-C0016	31223332
10,00	10	9,70	72	22	30	0,20	8	M7228P-1000AQ-C0020	31223333
12,00	12	11,60	83	26	36	0,24	8	M7228P-1200AQ-C0024	31223334
16,00	16	15,50	92	32	42	0,32	8	M7228P-1600AQ-C0032	31223335

Available on request

20,00	20	19,40	104	38	52	0,40	8	M7228P-2000AQ-C0040	31223336
-------	----	-------	-----	----	----	------	---	---------------------	----------

Configurable features



Shank form:
Shank form: HB



Specification:
M7228P-1200[shank form]Q-C0024

Example:
M7228P-1200**BQ**-C0024

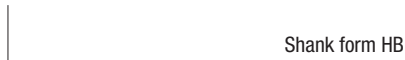

Dimensions in mm.

For cutting data recommendations, see end of chapter.

Special designs and other coatings available upon request.

OptiMill®-Composite-Speed-Plus

Shoulder milling cutter, design with pushing cutting edge
M7238P, follow-up product of M7238

Design:

Diameter of milling cutter: 4.00 - 20.00 mm
Coating: Diamond-coated
Number of cutting edges: 8
Helix angle: -8 °
Special features: Diamond coating

Application:

Roughing and finishing of CFRP in one machining step. Pushing cutting edge, where the material is pressed onto the base (e.g. very suitable for vacuum clamping). Particularly suitable for difficult to machine surface layers (e.g. UD or copper mesh) to prevent delamination on the upper edge of the part.

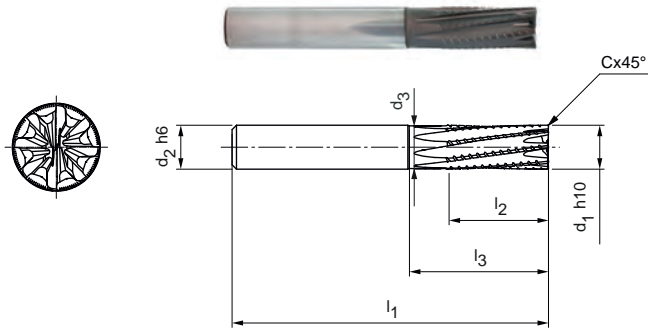

N	1.1	1.2	1.3	1.4	2.1	2.2	2.3	3.1	3.2	4.1	4.2	4.3	C	1.1	1.2	1.3	2.1	3.1	4.1	4.2	5.1	5.2	5.3	

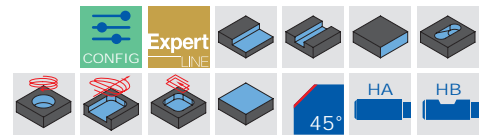

Preferred series available from stock

Dimensions							z	Specification	Order no.
d1 h10	d2 h6	d3	l1	l2	l3	Cx45°			
4,00	6	3,90	57	11	–	0,08	8	M7238P-0400AQ-C0008	31223337
5,00	6	4,90	57	13	–	0,10	8	M7238P-0500AQ-C0010	31223338
6,00	6	5,80	57	13	19	0,12	8	M7238P-0600AQ-C0012	31223339
6,00	6	5,80	65	21	27	0,12	8	M7238P-0600AQ-C0012	31223340
8,00	8	7,80	63	19	25	0,16	8	M7238P-0800AQ-C0016	31223341
8,00	8	7,80	70	22	32	0,16	8	M7238P-0800AQ-C0016	31223342
10,00	10	9,70	72	22	30	0,20	8	M7238P-1000AQ-C0020	31223343
12,00	12	11,60	83	26	36	0,24	8	M7238P-1200AQ-C0024	31223344
16,00	16	15,50	92	32	42	0,32	8	M7238P-1600AQ-C0032	31223345

Available on request

20,00	20	19,40	104	38	52	0,40	8	M7238P-2000AQ-C0040	31223346
-------	----	-------	-----	----	----	------	---	---------------------	----------

Configurable features



Shank form:
Shank form: HB



Specification:

M7238P-1200[shank form]Q-C0024

Example:

M7238P-1200BQ-C0024

Shank form HB

Dimensions in mm.

For cutting data recommendations, see end of chapter.

Special designs and other coatings available upon request.

Cutting data recommendations for shoulder milling cutters

Feed and cutting speed

Groove milling

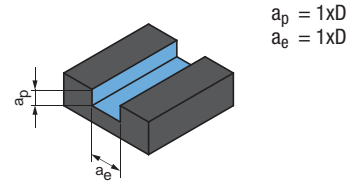

OptiMill-Composite-Speed-Plus, uncoated | M7248P, M7258P

MMG*	Workpiece material	Strength/hardness [N/mm ²] [HRC]	Cooling			v _c [m/min]	f _z [mm]							
			MQL/Air	Dry	KSS		Diameter of milling cutter [mm]							
							4.00	6.00	8.00	10.00	12.00	16.00	20.00	
N N4	N4.1	Plastic, thermoplastics	✓	✓	✓	125								
	N4.2	Plastic, duroplastics	✓	✓	✓		0.020	0.029	0.038	0.045	0.052	0.063	0.072	
	N4.3	Plastic, foam materials	✓	✓										
C C1 C2 C4	C1.1	Plastic range, reinforced with aramid fibre (AFK)	✓	✓	✓	120								
	C1.2	Plastic range (duroplastic), CFK/GFK	✓	✓	✓		0.021	0.026	0.031	0.035	0.038	0.042	0.043	
	C1.3	Plastic range (thermoplastic), CFK/GFK	✓	✓	✓		80	0.021	0.026	0.031	0.035	0.038	0.042	0.043
	C2.1	Carbon range, reinforced with carbon fibre (CFC)	✓	✓	✓	120	0.018	0.023	0.027	0.031	0.033	0.037	0.038	
	C4.1	Sandwich construction, honeycomb core (Honeycomb)	✓	✓		165	0.012	0.015	0.017	0.019	0.021	0.023	0.024	
	C4.2	Sandwich construction, foam core	✓	✓		125	0.019	0.024	0.028	0.032	0.035	0.039	0.041	

OptiMill-Composite-Speed-Plus, coated | M7228P, M7238P

MMG*	Workpiece material	Strength/hardness [N/mm ²] [HRC]	Cooling			v _c [m/min]	f _z [mm]						
			MQL/Air	Dry	KSS		Diameter of milling cutter [mm]						
							4.00	6.00	8.00	10.00	12.00	16.00	20.00
C C1 C2 C4	C1.1	Plastic range, reinforced with aramid fibre (AFK)	✓	✓	✓	145							
	C1.2	Plastic range (duroplastic), CFK/GFK	✓	✓	✓		0.021	0.026	0.031	0.035	0.038	0.042	0.043
	C1.3	Plastic range (thermoplastic), CFK/GFK	✓	✓	✓		100	0.021	0.026	0.031	0.035	0.038	0.042
	C2.1	Carbon range, reinforced with carbon fibre (CFC)	✓	✓	✓	145	0.018	0.023	0.027	0.031	0.033	0.037	0.038
	C4.1	Sandwich construction, honeycomb core (Honeycomb)	✓	✓		195	0.012	0.015	0.017	0.019	0.021	0.023	0.024
	C4.2	Sandwich construction, foam core	✓	✓		150	0.019	0.024	0.028	0.032	0.035	0.039	0.041

* MILLER machining groups

Roughing

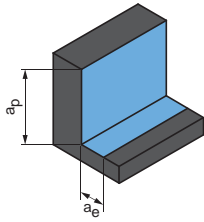

$a_p = 1.5xD$
 $a_e = 0.25xD$

Finishing

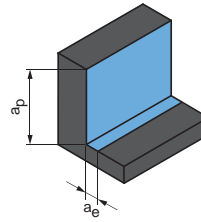

$a_p = 1.5xD$
 $a_e = 0.1xD$

	v_c [m/min]	f_z [mm]							v_c [m/min]	f_z [mm]						
		Diameter of milling cutter [mm]								Diameter of milling cutter [mm]						
		4.00	6.00	8.00	10.00	12.00	16.00	20.00		4.00	6.00	8.00	10.00	12.00	16.00	20.00
	190	0.029	0.041	0.053	0.063	0.072	0.089	0.101	230	0.040	0.057	0.073	0.088	0.101	0.123	0.141
	200	0.021	0.026	0.031	0.035	0.038	0.042	0.043	295	0.021	0.026	0.031	0.035	0.038	0.042	0.043
	135	0.021	0.026	0.031	0.035	0.038	0.042	0.043	195	0.021	0.026	0.031	0.035	0.038	0.042	0.043
	200	0.018	0.023	0.027	0.031	0.033	0.037	0.038	295	0.018	0.023	0.027	0.031	0.033	0.037	0.038
	270	0.012	0.015	0.017	0.019	0.021	0.023	0.024	395	0.012	0.015	0.017	0.019	0.021	0.023	0.024
	200	0.019	0.024	0.028	0.032	0.035	0.039	0.041	300	0.019	0.024	0.028	0.032	0.035	0.039	0.041

	v_c [m/min]	f_z [mm]							v_c [m/min]	f_z [mm]						
		Diameter of milling cutter [mm]								Diameter of milling cutter [mm]						
		4.00	6.00	8.00	10.00	12.00	16.00	20.00		4.00	6.00	8.00	10.00	12.00	16.00	20.00
	240	0.021	0.026	0.031	0.035	0.038	0.042	0.043	355	0.021	0.026	0.031	0.035	0.038	0.042	0.043
	160	0.021	0.026	0.031	0.035	0.038	0.042	0.043	235	0.021	0.026	0.031	0.035	0.038	0.042	0.043
	240	0.018	0.023	0.027	0.031	0.033	0.037	0.038	355	0.018	0.023	0.027	0.031	0.033	0.037	0.038
	325	0.012	0.015	0.017	0.019	0.021	0.023	0.024	480	0.012	0.015	0.017	0.019	0.021	0.023	0.024
	245	0.019	0.024	0.028	0.032	0.035	0.039	0.041	360	0.019	0.024	0.028	0.032	0.035	0.039	0.041

The specified machining values are guide values.
 The optimum data for the respective machining task should be determined during the test or machining.

Your specialist for solid carbide drills
and milling cutters

Solid carbide drills for steel, aluminium,
stainless steel and hardened materials

High performance drills with more cutting edges
and additional margin lands

Replaceable head drill TTD

Solid carbide milling range for steel, aluminium,
stainless steel and hardened materials

High-performance milling cutters
for high machining volumes

Tool product line for machining modern
workpiece materials and super alloys

