

SWISS MODULAR[®]

by Triag International AG

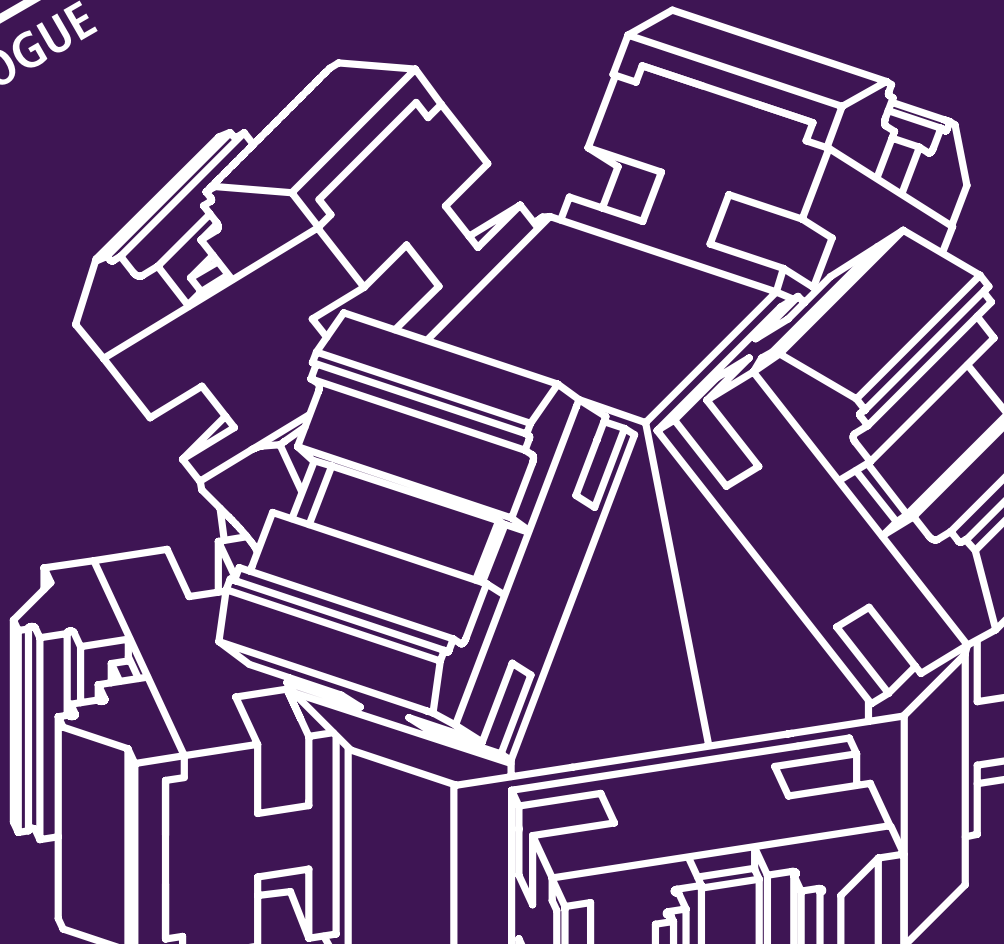

Inhalt Content

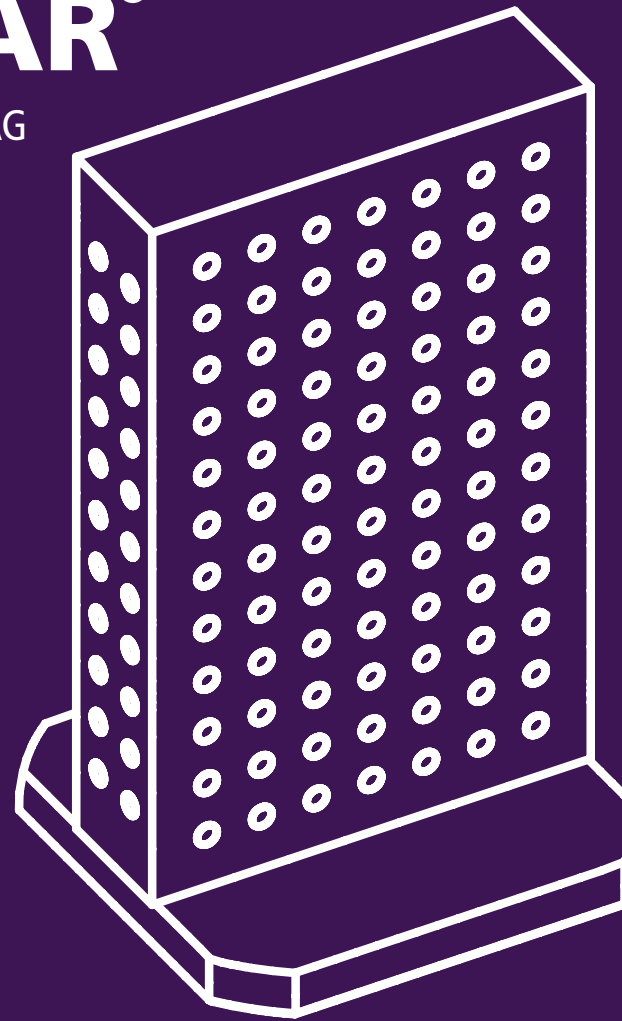
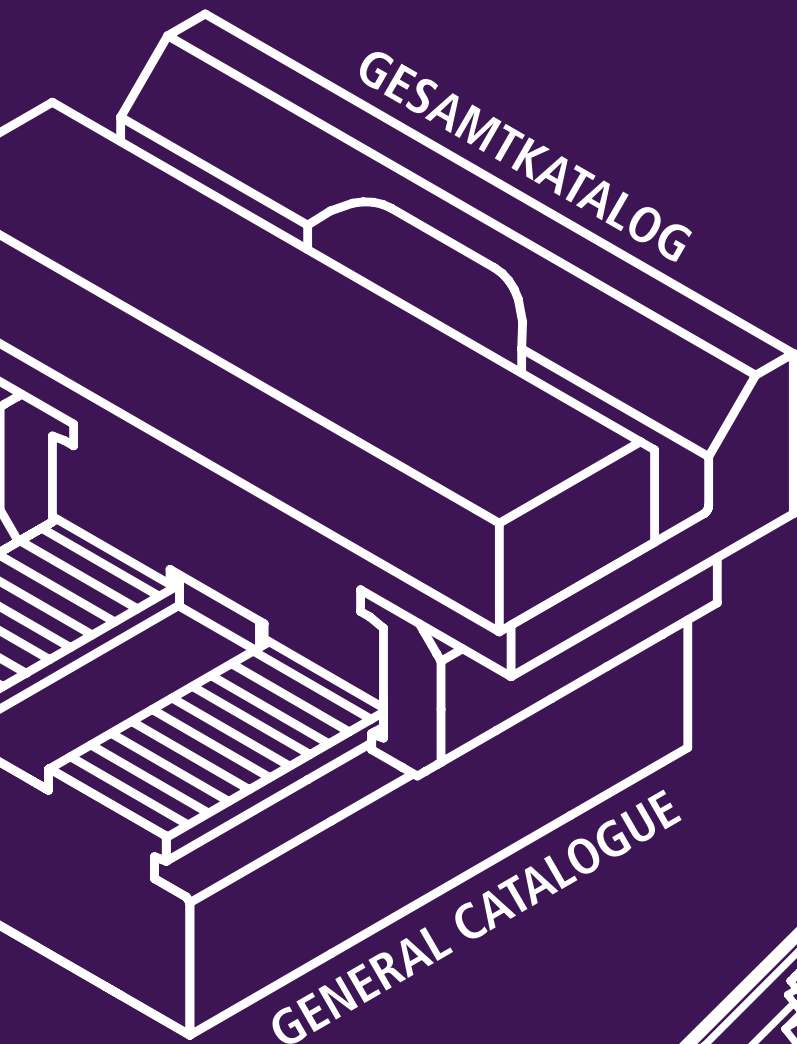

powerCLAMP

13 - 112

Der Lego-Schraubstock 3D Modular
The lego-vise - 3D modular



triCENTRO

113 - 162

Modulare Zentrischspanner
Modular self centering vises



microCLAMP

163 - 206

Spannmodule für den Vorrichtungsbau
Clamping modules for dedicated fixtures

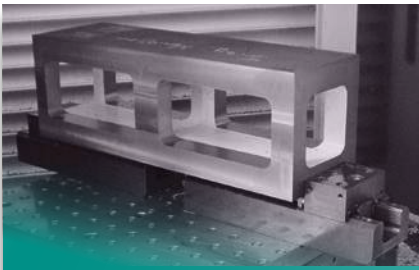

aptoCLAMP

207 - 234

Das stärkste Spannsystem
The strongest workholding system

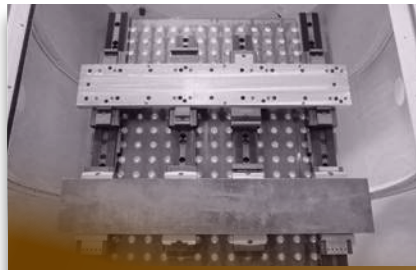

tripoxyMINERAL

235 - 278

Eliminiert Vibrationen und ist leicht
Eliminates vibrations and is low in weight

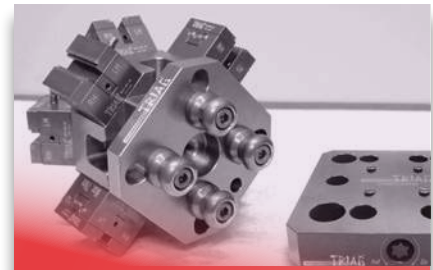

oppSYSTEM

279 - 302

Schneller Umrüsten mit Nullpunktsystemen
Zero point - quick change systems

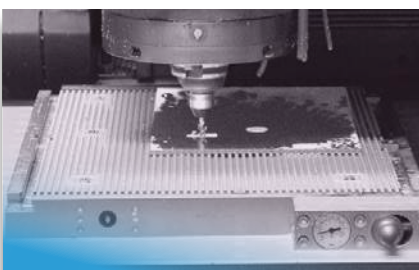

trivaCLAMP

303 - 328

Spannen mit Vakuum
Clamping with vacuum



SPECIALS

329 - 332

Sondervorrichtungen
Custom made fixtures



Zubehör / Accessoires

333 - 340

INDEX

341 - 346

Über uns About us

1990 Die Triag AG wurde im Jahr 1990 von Edi Zängerle, Ursula Landtwing und Beat Baumgartner gegründet. Sie vertrieb ihre Spannsysteme sowie Zerspanungswerkzeuge namhafter Hersteller hauptsächlich auf dem Schweizer Markt.

2013 Am 1. Juli 2013 wird die Firma in die zwei Unternehmen Triag AG und Triag International AG aufgesplittet.

HEUTE Wir, die Triag International AG, konzentrieren uns seither auf die Entwicklung, Produktion sowie den weltweiten Vertrieb unserer modernen Spannsysteme. Sowohl mit unserem tiefen und breiten Standard Sortiment, als auch mittels werkstückspezifischen Sonderlösungen möchten wir unseren Kunden dabei helfen, ihren Maschinenraum optimal auszunutzen, um dadurch die grösstmögliche Effizienz zu erzielen. Unsere Spannsysteme können von der konventionellen Fräsmaschine bis hin zu modernen 5-Achs-Fräszentren mit oder ohne Automatisierung eingesetzt werden. Diese Effizienz nutzen wir auch in der Herstellung unserer Spannsysteme in unserer eigenen Fertigung. Das gesamte Sortiment an Spannsystemen und Mineralgusstürmen läuft seit 2023 unter der Marke swissMODULAR.

Auf ein gutes Arbeitsklima und unsere Umwelt legen wir sehr grossen Wert, denn nur mit einem funktionierenden Team und einem grossen Umweltbewusstsein können wir unsere Kunden offen und nachhaltig bedienen.

1990 Triag AG was founded in 1990 by Edi Zängerle, Ursula Landtwing and Beat Baumgartner. Triag AG distributed its clamping systems as well as cutting tools of well-known manufacturers primarily on the Swiss market.

2013 On July 1st, 2013, the company has been split up into the two companies Triag AG and Triag International AG.

TODAY Triag International AG concentrates on the development, manufacturing and worldwide distribution of our/its modern clamping systems since. With our wide range of standard products as well as by means of custom-built solutions we aim to help our customers to get the most out of their machine space in order to achieve the highest efficiency possible. Our modular workholding systems can be applied from conventional up to 5-axis milling machines, with or without automation. We benefit of this efficiency in the manufacturing of our clamping systems in our own production too. Since 2023, the whole range of clamping systems and epoxy mineral tombstones runs under the brand swissMODULAR.

We focus on a good working atmosphere and place great value on our environment. We believe that these factors are essential to provide an open and sustainable service.

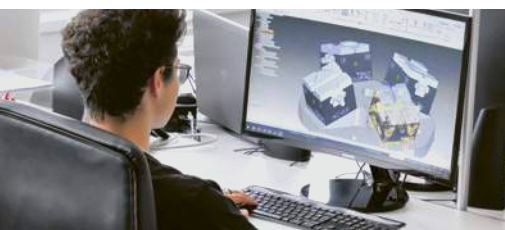

**Triag Internationa AG
laucht die neue Marke
swissMODULAR.
Die Marke umfasst das
gesamte Sortiment an
Spannsystemen und
Mineralgusstürmen**

**Entstehung der Triag
International AG und
der Schwesterfirma Tribur
Invent GmbH, die sich auf
den weltweiten Vertrieb
mit eigenem Engineering,
eigener Produktion und
eigener Mineralguss
Giesserei konzentrieren.**

Gründung der Triag AG

2023

**Triag International AG has
rebranded to swissMODULAR.
The new brand includes the
whole range of clamping
systems and epoxy mineral
tombstones.**

2013

**The formation of Triag
International AG and
the sister company Tribur
Invent GmbH, which are
focusing on worldwide
distribution with their own
engineering, manufacturing
and epoxy mineral casting.**

1990

Foundation of Triag AG

Im Herzen der Schweiz
In the heart of Switzerland

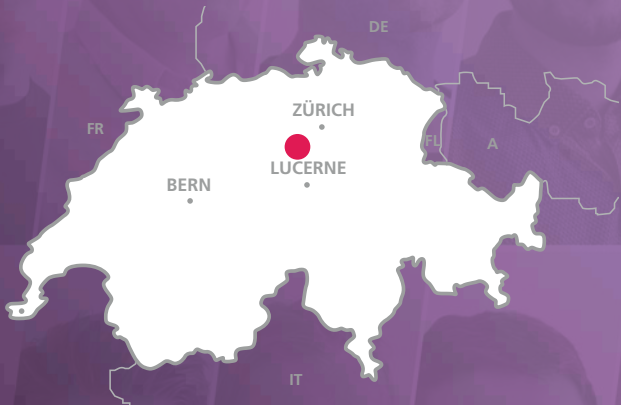
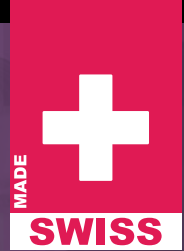

Triag International AG

Bösch 84 CH-6331 Hünenberg

☎ +41 41 727 27 77

✉ spannen@triag-int.ch

✉ clamping@triag-int.ch

www.triag-int.ch



Langfristige Kundenbeziehungen
Long-term customer relations

Respektvolle Teamarbeit
Respectful teamwork

Lehrlingsausbildung
und faire Lohnpolitik
*Apprenticeship and
fair wage policy*

swiss 
MODULAR[®]

by Triag International AG

Erstklassige Qualität
zu fairen Preisen
*First class quality
with fair pricing*

Wir respektieren unsere Umwelt
We respect our environment



Time to say goodbye
to the dinosaur vises!



RAUM SPACE

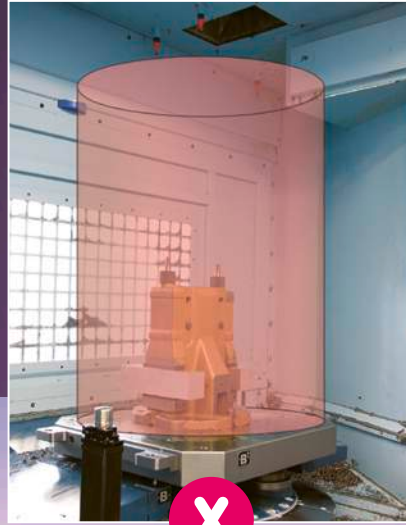

«In Gebäuden ist es doch auch üblich, den Raum komplett zu vermieten. Wieso nicht auch in Ihrer Maschine?»

«In buildings, it is common to rent out the full space. Why not in your machine?»

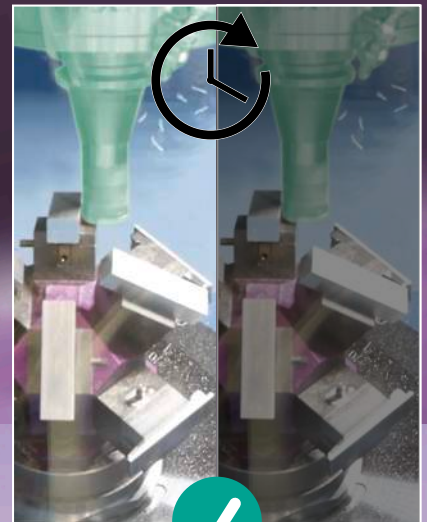
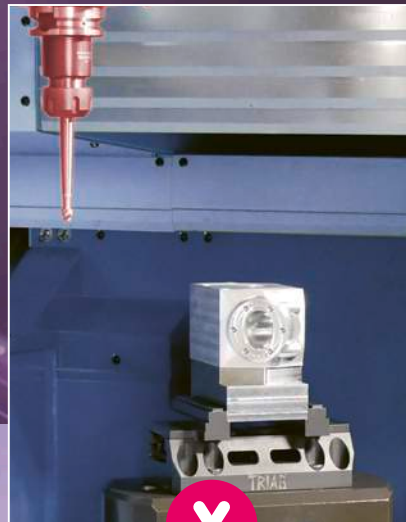

«Flugzeuge sollen möglichst kurze Zeit geparkt bleiben. Das gleiche gilt für die Frässpindel.»

«Aircrafts should remain parked for the shortest amount of time. The same rule applies to the milling spindle.»



Die Effizienzreserven
The efficiency reserves

swiss 
MODULAR[®]

MUESLI CEREAL



«Eine gute Mischung gibt ein gutes Müesli, warum dann nicht auch beim Fräsen?»

«A good mixture makes a good cereal, so why not also when milling?»

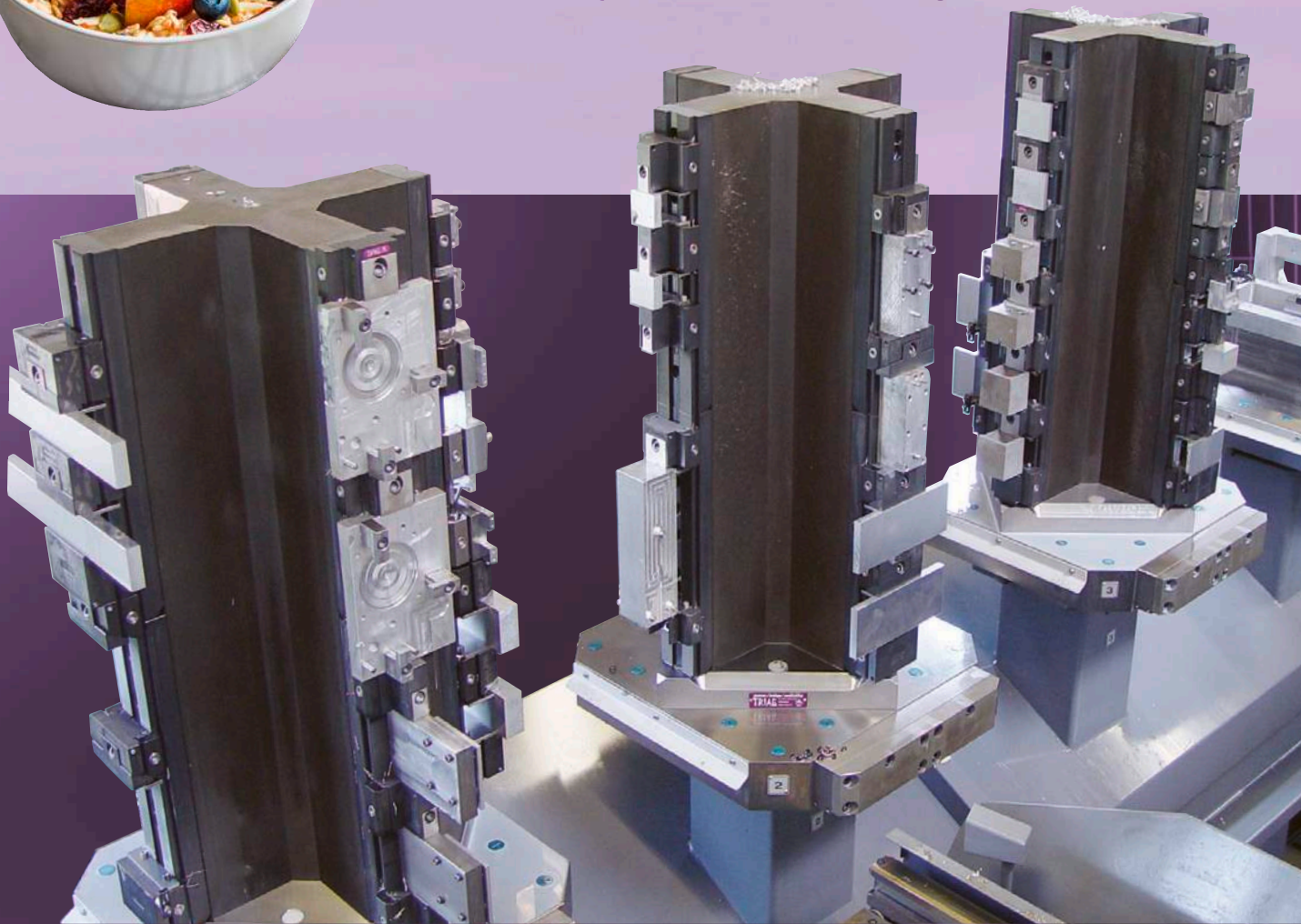

**CHAOTISCHE
PRODUKTION**

**MIXED
PRODUCTION**

«Modular» bedeutet:

3 dimensionales Anpassen an Werkstück und Maschine

Vorteile des modularen Mehrfachspannens:

- Möglichkeit der chaotischen Produktion
- Schneller Werkstückwechsel
- Vielseitigkeit durch Kombination mehrerer Komponenten, 3D modular (Schienen, mechanisch oder hydraulisch betätigte Spannelemente etc.)
- Einfache Montageprozesse
- Lange Lebensdauer, geringe zusätzliche Instandhaltungskosten
- Beschädigte Komponenten können einfach ersetzt werden
- Längere unbemannte Laufzeit
- Deutlich weniger Werkzeug- und Palettenwechsel
- Schont die Maschine, da der gesamte Bearbeitungsraum genutzt wird
- Preis: Kann trotz der Vorteile mit einem Spannstock mithalten
- Geringerer Aufwand in der Logistik, Lagerhaltung und Beschaffung
- Höhere Spanndichte, mehr Teile aufgespannt
- Spannen von kleinen wie grossen Werkstücken

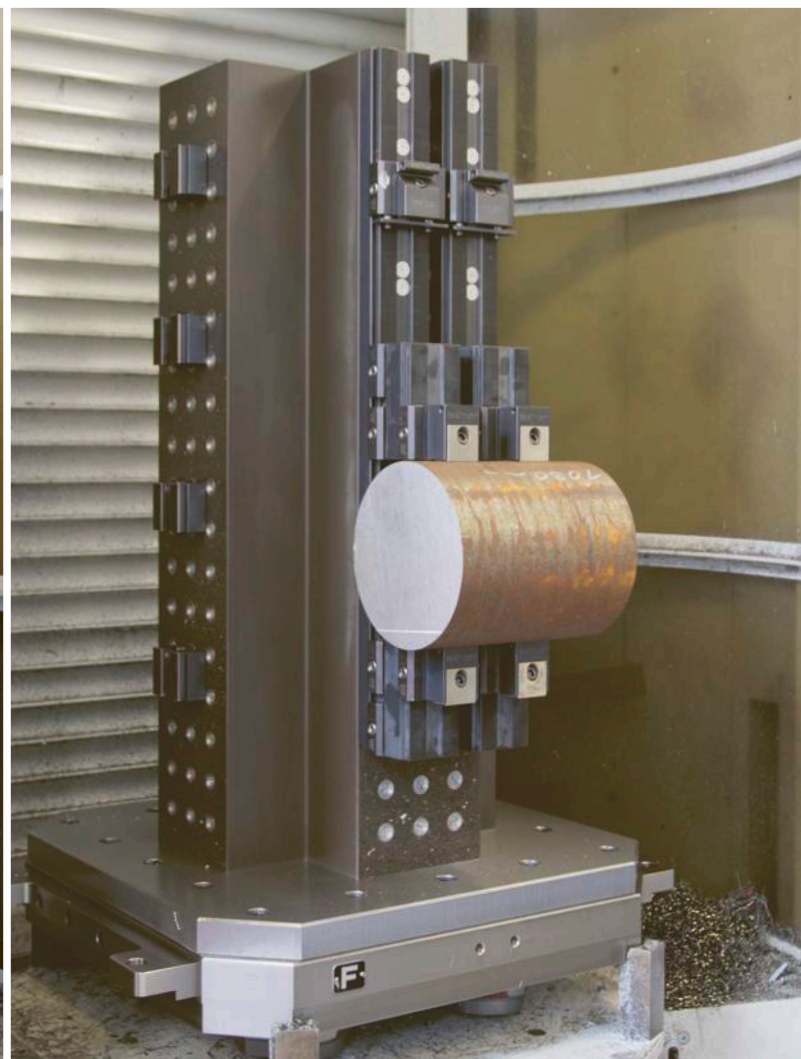
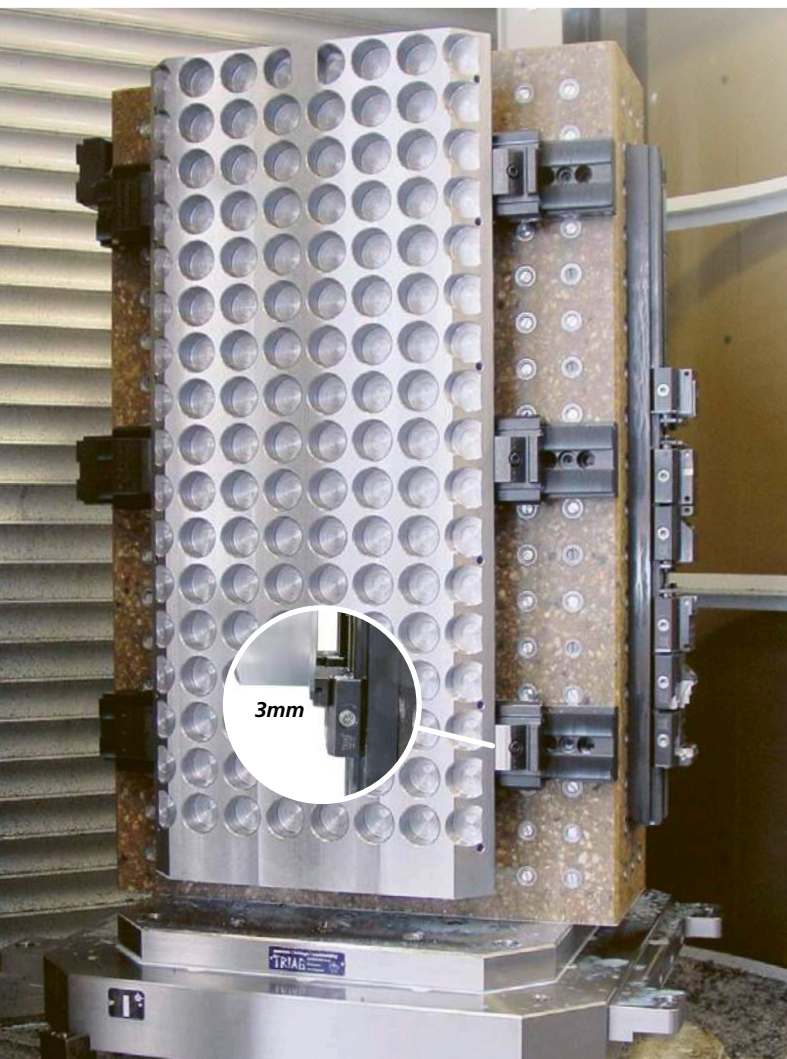

«Modular» means:

Adapting to workpiece and machine situation in 3 dimensions

Advantage of modular workholding:

- Possibility of chaotic manufacturing
- Fast workpiece change
- Flexibility because of different components, 3D modular
- Simple to set up
- Cost effective
- Easy to replace spare parts
- Long unmanned production
- Less tool changes
- The machines are used in the whole working area
- Competitive price to standart vises
- Simple to be purchased and used on different machines
- High density workholding, you clamp more parts!
- Long and reliable live with low maintenance cost

Chaotische Spannung für das Erledigen von verschiedenen Jobs gleichzeitig.
Optimale Nutzung eines Horizontal-Bearbeitungszentrums.

*Mixed set up on a Mazak horizontal machine with
18 pallets. This is used for unmanned production of
small quantities of different materials.*

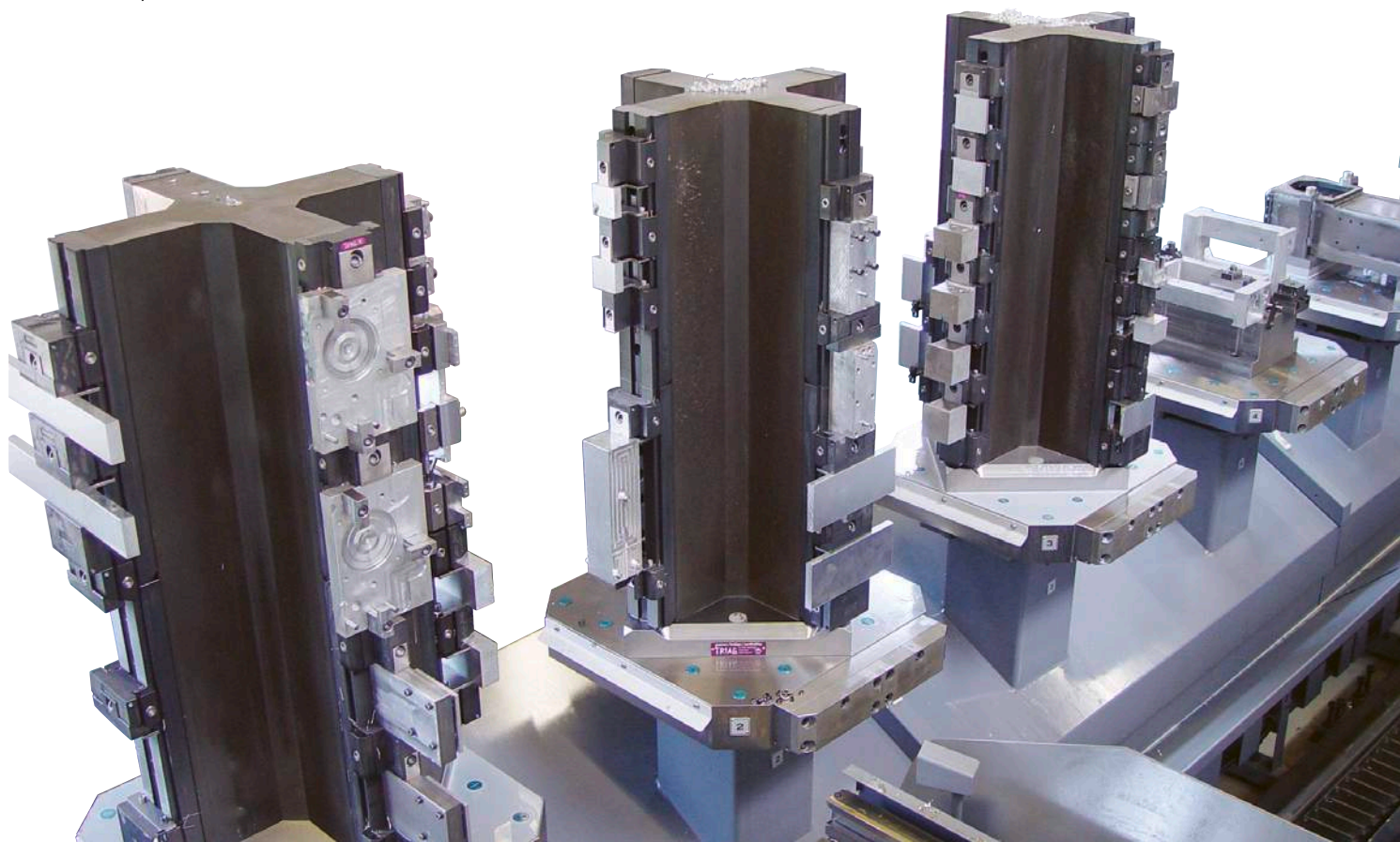

Modulare Mehrfachspannsysteme werden in ihrer Bedeutung für die Zerspanung noch immer unterschätzt. Dabei sind sie sowohl in der Einzelteilfertigung als auch für Grossserien flexibel einsetzbar. Zurückzuführen ist diese Flexibilität auf das Konstruktionsprinzip der Systeme, ihre handhabbare, kompakte Bauweise wie auch die hohe Spannkraft und Spanndichte.

Bei der Beurteilung modularer Mehrfachspannsysteme gibt es eine eigentümliche Konstellation: Zum einen sieht der Einzelteil- und Kleinserienfertiger enorme Vorteile für die Anwendung in der Serienfertigung, beispielsweise rückbaubarer Vorrichtungsbaukasten. Zum anderen erkennt der Serienfertiger genau diese Vorzüge für die Einzelteil- und Kleinserienfertigung. Diese Sichtweise zu hinterfragen und zu verdeutlichen, worin die fertigungsspezifischen Vorteile modularer Mehrfachspannsysteme liegen, ist Ziel des Beitrags.

Modulare Mehrfachspannsysteme sind flexibel anwendbar

Für viele Zerspanungsarbeiten ist der klassische Maschinenschraubstock auch heute noch die passende Spannung. Mit den ständig neuen und erhöhten Anforderungen geht allerdings die Entwicklung der Spanntechnik in eine andere Richtung. Will man ein hohes Mass an Flexibilität und eine grosse Spanndichte erzielen und sollen gleichzeitig verschiedene Werkstücke auf kleinstem Raum gespannt werden, kommt der klassische Maschinenschraubstock oft an seine Grenzen. Häufig führt hier nur ein modulares Mehrfachspannsystem zum Erfolg. Spannsysteme müssen heute möglichst flexibel sein. Damit lassen sie sich an veränderte Umstände anpassen und können so die Wirtschaftlichkeit des Bearbeitungsprozesses erhalten. Modular ist ein Spannsystem, wenn es nach dem Baukastenprinzip aus Elementen zusammengesetzt und erweiterbar ist. Neben diesen grundsätzlichen Eigenschaften bedarf das Spannsystem jedoch weiterer prägnanter Merkmale: So muss es einfach und schnell zu handhaben sein, eine kompakte Bauweise mit hoher Spannkraft und Spanndichte verbinden und möglichst autarke Spannstellen aufweisen, deren Spanndruck einzeln zu verstellen ist. Im Idealfall kann mit nur einer Basisschiene ein breites Backenprogramm mit geringem Aufwand aufgebaut werden.

In der Serienfertigung besteht der wohl grösste Vorteil modularer Mehrfachspannsysteme darin, dass sich das System als rückbaubarer Vorrichtungsbaukasten für ein vielseitig gefächertes Werkstückspektrum einsetzen lässt. So spart sich der Anwender oft teilespezifische, teure Vorrichtungen. Mehrfachspannsysteme können zudem das Engineering vereinfachen, da sich auf vorhandenes Spannmateriale zurückgreifen lässt. So sind kurze Planungs- und Umrüstzeiten realistisch. Darüber hinaus trägt das modulare System zur erhöhten Prozesssicherheit bei und fördert die Qualitätstreue, die heute ein elementares, unabdingbares Kriterium der modernen Fertigung ist. Schliesslich ist ein Mehrfachspannsystem mit mehreren unabhängigen Spannstellen auch für den Einsatz in der Serie ideal, da so mehrere Werkstückspannungen mit unterschiedlichen Parametern möglich sind.

Anwendung ist bei horizontalem und vertikalem Aufbau möglich

Häufig wird bei der Serienfertigung eine Maschine mit horizontalem Aufbau, Palettenbahnhof und Spanntürmen verwendet. Was aber ist mit vertikalen Bearbeitungszentren? Wo liegen hier die Vorteile eines Mehrfachspannsystems? Spanntürme, die in der Serienfertigung mit modularen Mehrfachspannsystemen bestückt werden, weisen eine hohe Spanndichte auf, die zur verlängerten Spindelzeit führt. Gleichzeitig ist auch eine hervorragende Zugänglichkeit der Werkzeuge gewährleistet.

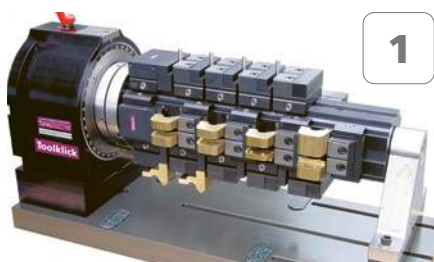

1

Vertikalmaschinen, deren komplette Tischflächen mit einem modularen Mehrfachspannsystem bestückt sind, ermöglichen Spanndichten, die denen auf Horizontalmaschinen gleichen

Mit einer vierten Achse kann eine Vertikalmaschine zur Serienmaschine mit Mehrseitenbearbeitung aufgerüstet werden, wobei auch hier eine hohe Spanndichte und Zugänglichkeit erreicht wird. Die horizontale und die vertikale Strategie lässt sich mit dem gleichen Spannsystem umsetzen, was bei Maschinenausfall mitunter eine echte Problemlösung darstellt.

Autarke Spannstellen sind auch für die Kleinserie wichtig

In der Einzelteil- und Kleinserienfertigung spielen modulare Mehrfachspannsysteme grundsätzlich die gleichen Vorteile wie in der Serienfertigung aus: hohe Spanndichte, geringere Werkzeugwechselzeiten, bessere Tischauslastung, gute Zugänglichkeit, einfache Handhabung, einfaches Engineering. Besonders wichtig ist hier jedoch die Flexibilität der Spanntechnik. Gerade bei kleinen Losgrößen geht viel Zeit beim Umrüsten verloren. Um diesen Vorgang zu optimieren, ist der Einsatz modularer Spannsysteme häufig das einzige Mittel. Daher ist die schnelle Verstellbarkeit der einzelnen Spannstellen in Spanndruck, Backenbreite oder Backenausführung unabdingbar.

Autarke Spannstellen sind gerade für den Einzelteilfertiger immens wichtig. Mit ihnen kann er sicherstellen, dass sich verschiedene Werkstücke aus unterschiedlichen Materialien gleichzeitig und prozessspezifisch spannen lassen (siehe Bild 2).

Der notwendige Spanndruck wird dabei ebenso gewährleistet wie die Verformungsfreiheit des Werkstücks. Letztlich resultiert aus der höheren Spanndichte eine längere Spindelzeit. Bei wiederkehrenden Kleinserien ist die reproduzierbare Spannsituation sehr wichtig. Wie in der Grossserie kann auch bei Kleinserien oder Einzelteilen die Tischfläche mit einem Mehrfachspannsystem besser ausgenutzt, der Werkzeugwechsel reduziert und die Wirtschaftlichkeit erhöht werden (siehe Bild 3).

Bei genauer Betrachtung der verschiedenen Fertigungsstrategien - Horizontal- oder Vertikal-BAZ sowie Serien-, Einzelteil- oder Kleinserienfertigung- wird die Vermischung der Verfahren deutlich. Die vermeintlichen Unterschiede sind oft nicht gross. Auch ist die Investition, die beim Übergang von einer Strategie zur anderen notwendig wird, jederzeit vertretbar und zu argumentieren. So erweist sich beispielsweise eine hochwertige Spannschiene mit drei oder vier Spannstellen als weitgehend preisneutral zu einem klassischen Maschinenschraubstock.

Für viele Anwendungen sind modulare Mehrfachspannsysteme ein echter Problemlöser und daher unumgänglich. Dies gilt sowohl für den Einsatz in der Serie als auch in der Einzelteilfertigung. Insofern haben beide Anwender - um zum Anfang zurückzukehren - mit ihrer Sichtweise recht. Nur gelten die Vorteile eben nicht nur für den jeweils anderen Bereich, sondern vor allem auch für den eigenen.

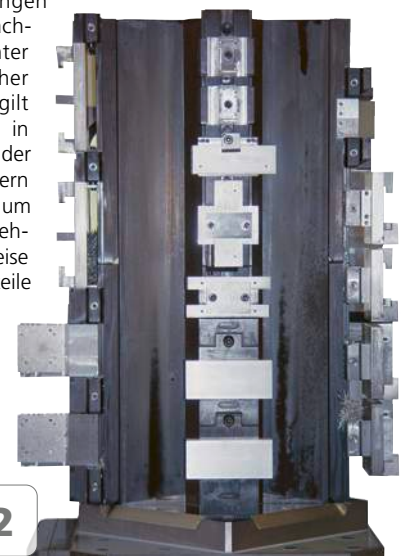

2

Kleinserienfertigung auf Horizontalmaschinen: Autarke Spannstellen ermöglichen die gleichzeitige, spezifische Fixierung unterschiedlicher Werkstücke.

Small batch production of different work pieces on a horizontal machining centre (family of parts)

The dormant potential

From the press

Modular and multiple workholding systems are still underestimated in their economic potential. But they have proven their point in many practical applications in batch production, in some cases even on small series. This is due to their modular, compact design resulting in a very high workpiece density. In spite of their compact size, the clamping force is considerable. Producers of small batches see the advantages of these systems mainly in the quantity production, whereas the mass producer uses these modular vice elements on some occasions to quickly set up a fixture for only a few parts. The reason for this fact you will find in this editorial.

Modular workholding systems are very flexible in their use

For many machining applications the classical machine vice is still the suitable workholding solution. Since the introduction of the CNC machining centres the demand for flexible, modular systems has constantly increased. These systems allow the accommodation of many parts in a limited workspace. Also the number of tool changes are considerably reduced, which means less machining time per part and longer spindle time between the loading stops. Consequently the machine productivity goes up.

Modern multiple workholding systems must be flexible. The setting up of their modules must be simple and quick. The kit like components have to be adaptable to many different workholding configurations, just by placing them into other locations or changing jaws. Their clamping force must be adjustable to protect the workpiece. In the ideal case the base rail must be able to accommodate many different vice modules and jaws.

In the production of larger batches the modular workholding systems have the greatest advantages. Their interchangeable modules can be placed to suit the workpieces often replacing expensive dedicated fixtures. Engineering of fixtures may be simplified.

Hence planning and set up from one part to the next can be shortened. Multiple workholding systems contribute also to more constant and precise parts improving the interchangeability of products, an important criterion in today's industrial world. In some cases it is even possible to clamp a family of parts in one setup. Some of our customers take advantage of this feature.

Installation possible on horizontal and vertical machines

On horizontal machines tombstones (fixture carrying towers) are often installed on the pallets. This arrangement allows for machining on three faces even with very high workpiece density. What about machines with vertical spindles? Where are the advantages of multiple workholding

systems on such machines. The machine table can be filled with several workholding systems side by side allowing many parts to be clamped in a small area. If an indexer (fourth axis) is installed with a bridge or a trunnion exactly the same machining features are possible as on a horizontal

The output of a vertical machine with a fully loaded table surface is similar to that of a horizontal machine.

machines – lots of parts even when machining on three faces. If independent base rails are used they can be installed vertically as well as horizontally. A high interchangeability of components gives good flexibility in case of a machine break down.

Multiple workholding also for small batch production and families of parts

A very important advantage besides the points mentioned for large quantity production, is the workholding of part families, particularly if the parts are produced at intervals. In such cases the flexibility and the simplicity of set up is of great importance. For instance shaped jaws may be stored in the tool room ready for the next production run. In some applications users build dedicated fixtures and install Compact Clamp or microCLAMP vice modules on their own fixtures (see picture 2).

Naturally the rail based systems like the Power Clamp or the Compact Clamp can be used as a conventional vice if only one vice module and one end module is used. For wider workpieces sometimes two or more systems are installed side by side. Doing that, the vice modules and the reference surfaces are aligned by the serrations or the pins in the base rail.

Again, the clamping of different workpieces allows the use of the same tool on various cuts therefore giving longer machining cycles and less tool changes (see picture 3).

The investment in a multiple workholding system with three or four workholding stations is about the same as that for a conventional machine vice. But the multiple workholding system gives the user much greater flexibility and versatility.



Die Verwendung von Mehrfachspannsystemen auch in der Kleinserienfertigung reduziert den Werkzeugwechsel und erhöht die Wirtschaftlichkeit.

The use of a multiple workholding system is also beneficial in small batch machining.

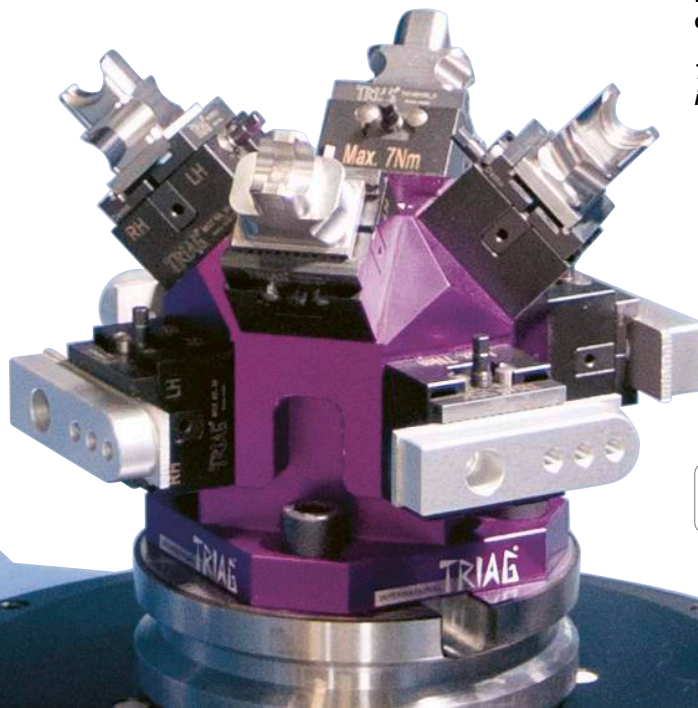

**Mehrfachspannung auf spaceGRIP 1
Multiple workholding on spaceGRIP 1**

Setzen Sie mit uns Potenziale frei!
Unlock the potential with us!



WIE? HOW?

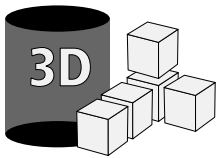

**3D-Modularität
für eine optimale
Raumnutzung**

*3D-Modularity for
an optimal use of
space*

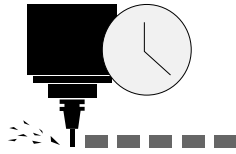

**Mehrfachspannung
für weniger
Maschinenstandzeit**

*Multiple workholding
for less machine down
time*

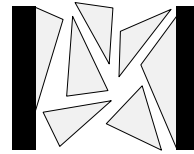

**Chaotisches Spannen für
das Erledigen von verschie-
denen Jobs gleichzeitig**

*Mixed clamping for the
manufacturing of different
jobs at the same time*

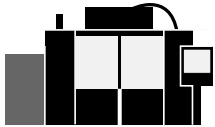

Grundvoraussetzung:
Zuverlässige Maschine mit
ausreichenden Werkzeug
und Paletten Plätzen und
eine geeignete Automati-
sierungsmethode









Basic requirement:
*Reliable machine with suf-
ficient tool an palett places
and a suitable automati-
sion method*



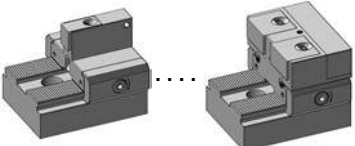
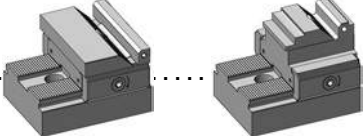

powerCLAMP **& 5axes**

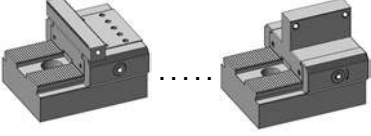

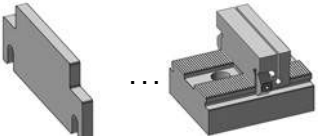
| | | |
|---|--|---|
|  | Einleitung <i>Introduction</i> | 15 - 21 |
|  | Bedienungsanleitung <i>Operating manual</i> Spannkraft und Drehmoment <i>Workholding force and torque</i> | 22 |
| | Anwendungsbeispiele <i>Examples of application</i> | 23 - 38 |
|  | System - Basisschiene <i>System - base-rail</i> |  41 - 57 |
| | Modular - Startersets <i>Modular - Starter kit</i> |  58 - 59 |
| | Niederzugspanmodule <i>Pull down clamp modules</i> |  60 - 73 |
| | Linearspannmodule mit Präge- und Linearbacken <i>Linear clamping modules with stamping and linear jaws</i> |  74 - 83 |
| | Backen zu Linear <i>Jaws for linear</i> |  82 - 84 |
| | Anschlagmodule <i>End module</i> |  85 - 92 |
| | Verschiedene Module <i>Different modules</i> |  93 - 105 |
| | Zubehör <i>Accessories</i> |  106 - 112 |

Warum modular Spannen Why modular workholding

powerCLAMP

Der klassische Maschinenschraubstock ist für gewisse Zerspanungsarbeiten vielfach die richtige Wahl, obwohl man einen Spannstock ohne Mehrkosten auch mit einem Modularsystem aufbauen kann. Er wird durch die ständig erhöhten Anforderungen an die Prozessoptimierung immer mehr durch modulare Spannsysteme ersetzt.

The classic machine vise is for some application still a good option, on the other hand can you set up the same with a modular clamp system at not higher costs! Because of always increasing demand and high competition you see more modular systems at endusers places, to keep up with productivity.

Mit den modularen Systemen wird ein hohes Mass an Flexibilität und grosser Spanndichte erreicht. Dies führt auch bei der Einzelteil- und Kleinserienfertigung zur Senkung der kostenintensiven Nebenzeiten, die einen wichtigen Faktor in der Wertschöpfungskette darstellen. Gegenüber Vorrichtungen ist der Vorteil, dass bei einem modularisiertem Aufbau die Aufspannung aus einem Baukastensystem (also standardisierten Einzelbauteilen) besteht, die kostengünstiger sind und für andere Aufspannungen wiederverwendet werden können. Zudem wird für die 3-Seitenbearbeitung eine gute Zugänglichkeit zum Werkstück gewährleistet.

With modular clamp system you achieve a high flexibility and also high density of holding workpieces. This brings you big advantages also by producing single parts or small quantities! Compared to dedicated fixtures you can use this vises for many different applications.

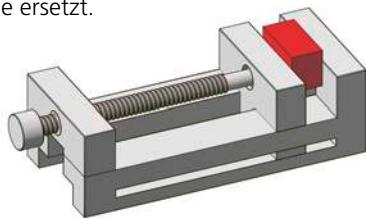

Spannen mit dem Spannstock
Clamping with the machine vise

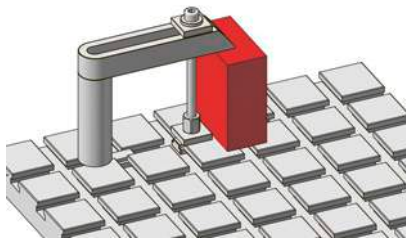

Spannen mit Spannpratzen
Clamps in operation

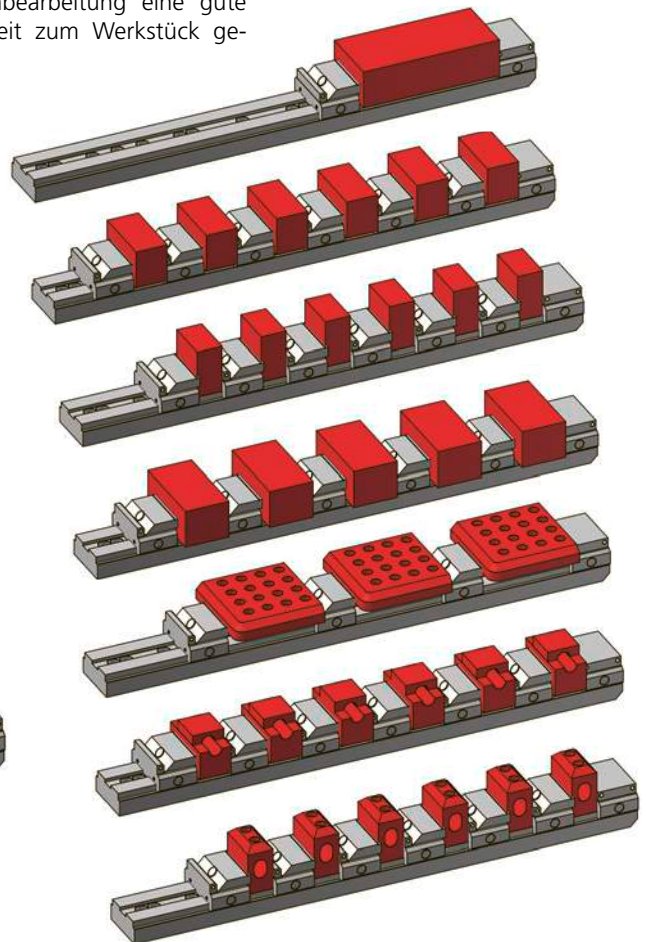
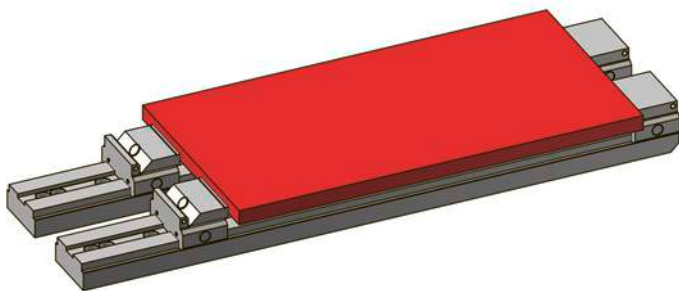

Ausserdem / And:

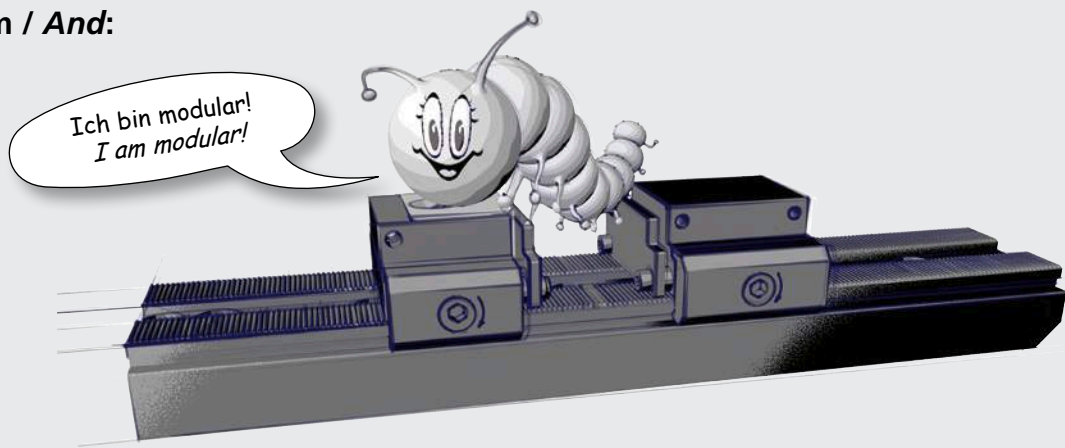

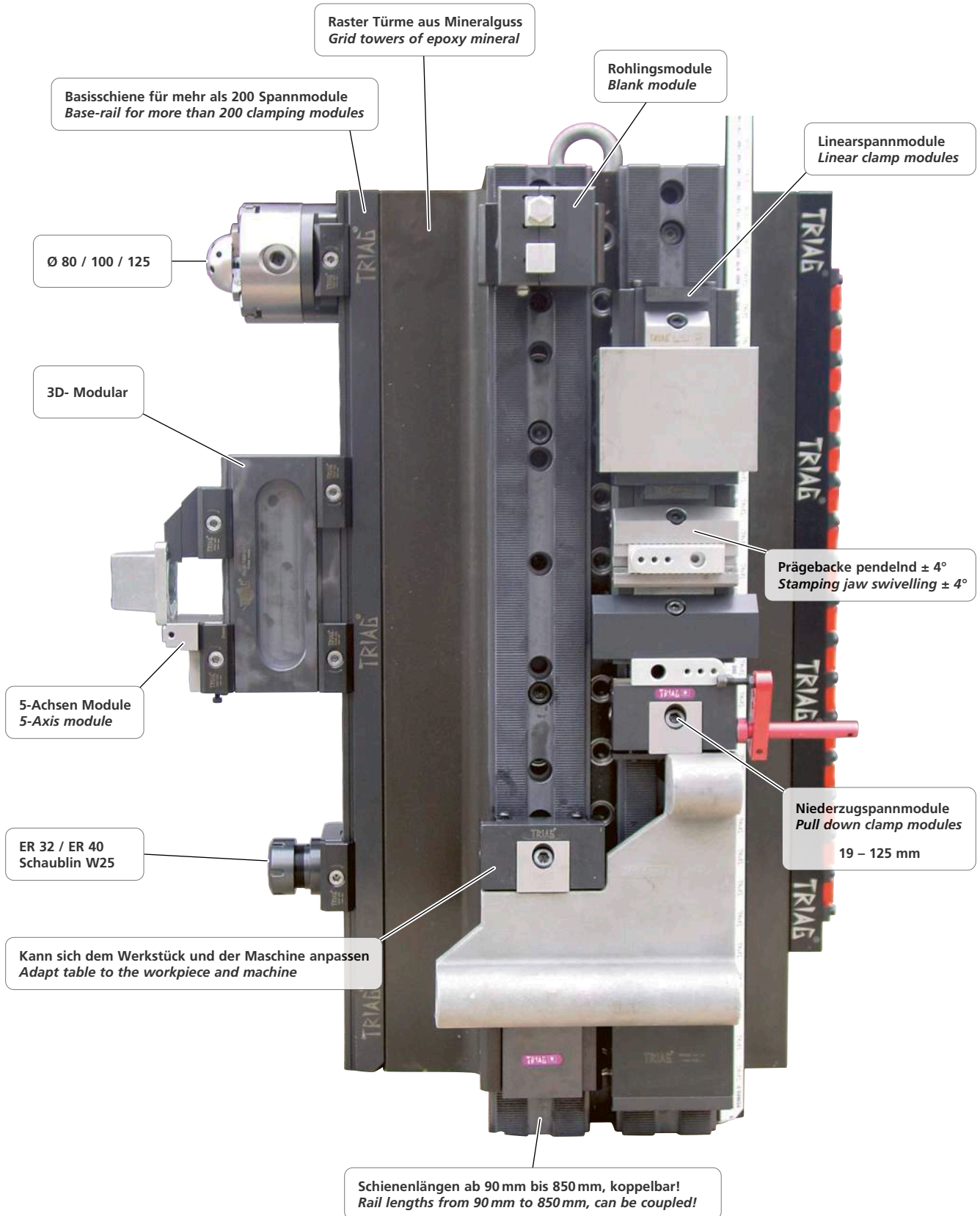

Modulares Spannen = Einzelspannung, Mehrfachspannung sowie auch das Spannen von kleinen, grossen oder unförmigen Werkstücken. Chaotisches, gemischtes spannen!

Modular workholding = Single clamping, multiple clamping small parts and large workpieces can be clamped, also shaped parts are possible to clamp. Mixed setups in chaotical clamp situation!

Mit dem Spannsystem Power Clamp hat die Triag International ein Produkt entwickelt, welches die Vorteile des klassischen Maschinenschraubstocks mit der Modularität eines innovativen Spannsystems in einer optimalen Art und Weise kombiniert und eine enorme Vielseitigkeit bietet. Einfache Spannungen sind genauso möglich wie Mehrfachspannungen und Spannungen von schwierigen Werkstücken.

With Power Clamp Triag has developed a product which includes the advantages of a classical vise and has the features of an advanced modular system. It can be used to clamp single parts (small and big) or multiple workholding as well as difficult to clamp parts.

Schnelligkeit / Quickness



1

Eine Schraube lösen
Loosen a screw



2

Abheben und neu platzieren
lift and change position



3

Eine Schraube anziehen
fasten one screw

Mit nur einer Schraubspindel, welche von beiden Seiten her zugänglich ist, werden die positionierten Module in einem patentierten Pratzensystem zuverlässig geklemmt.

Die Module können an jeder Stelle der Trägerschienen aufgesetzt werden. Verglichen mit dem üblichen axialen Aufschieben beschleunigt das den Aufbau von Mehrfachspannern und ermöglicht, diese Spannsysteme auch bei beengten Platzverhältnissen komfortabel zu rüsten.

With only one bolt screw (left and right hand thread) the clamp modules can be lifted and change position in 2mm steps.

This patented system is unique and fast, as well as accurate.



4

Drehmoment beachten
Observe the torque

Geringses Gewicht Low weight



= Einfaches Handling
= Easy handling

Das Modul kann mit zwei Fingern abgehoben werden.
The clamp module can be moved by two fingers.



Einfache Reinigung Easy cleaning

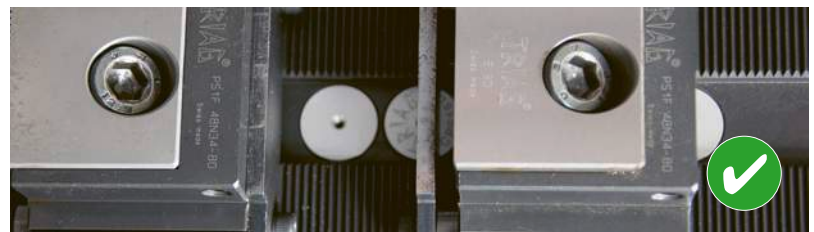

Keine spänefüllenden T-Nuten (im Gegensatz zu vielen Wettbewerbsprodukten) - Basis bilden stabile, mit Teilstücken verlängerbare Trägerschienen. Sie verfügen über eine hochgenau gefräste Verzahnung.

Eine Vielzahl an Spannmodulen mit unterschiedlichen Spannelementen lassen sich auf den Trägerschienen in einem Raster von 2 mm positionieren.

No chip catching T-slots (opposite of many competitors). The base rails are rigid and can be used modular in length width and height. The serration is accurate and checked for each base rail.

Many different clamp modules can be used on only one type base rail (step 2 mm)

Basisschienen / Base rails

Masssystem / Measurement system = metric & inch **powerCLAMP**

90 mm

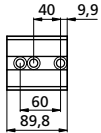

125 mm

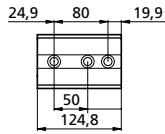

220 mm

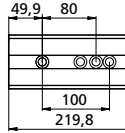

250 mm

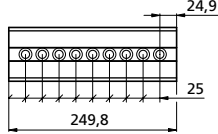

350 mm

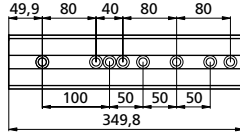

400 mm

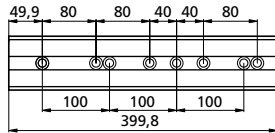

450 mm

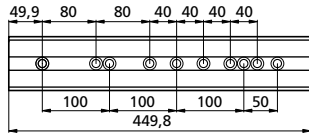

500 mm

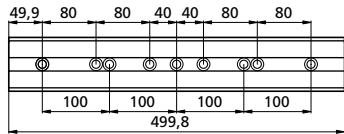

550 mm

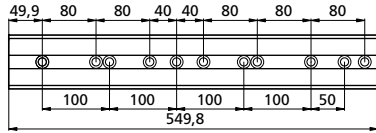

600 mm

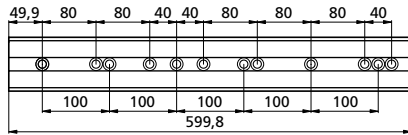

650 mm

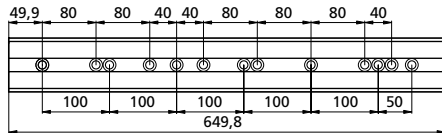

700 mm

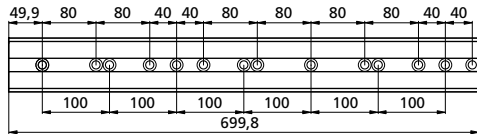

750 mm

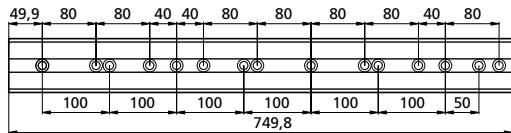

800 mm

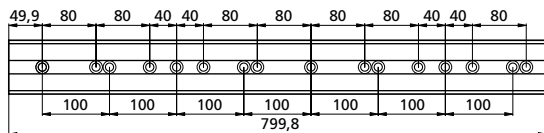

Schienen sind in den folgenden Höhen lieferbar:
Rails are in following ups available:

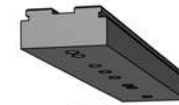

➔ 35 mm

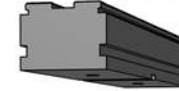

➔ 60 mm

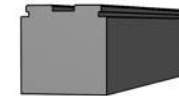

➔ 80 mm

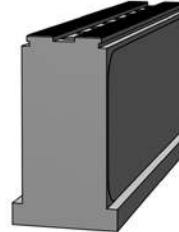

➔ 175 mm

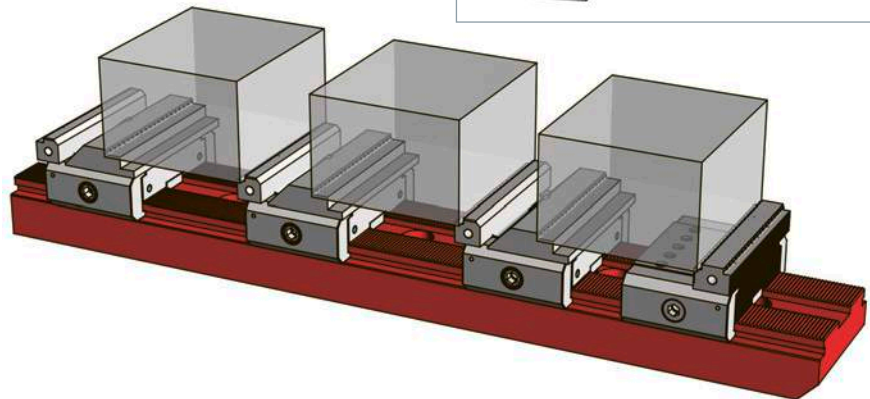

Basisschiene

Die Basisschiene ist das Grundelement des modularen Spannsystems von Triag International und ist in den Höhen 35 mm, 60 mm, 80 mm und 175 mm verfügbar. Auf der Basisschiene werden alle Spann- und Anschlagmodule über eine Schraubspindel mit einer Haltekraft von 15.000 daN (= 15t) befestigt. Eine schnelle und genaue Positionierung ist durch die Verzahnung (2 mm Teilung) auf der Basisschiene gewährleistet und sorgt somit für kurze Rüstzeiten.

Durch den Einsatz von Erhöhungsmodulen wird die Werkstück-Zugänglichkeit speziell bei 5-Achsenmaschinen auch mit kurzen Werkzeugaufnahmen ermöglicht. Somit ist die Maximalgröße der Werkstücke nur noch durch die Maschinengröße eingeschränkt. Die Basisschiene dient in diesem Zusammenhang als mechanisches Nullpunktsystem.

Die Basisschienen sind für eine schnelle Aufspannung auf den gängigsten Palettsystemen konzipiert. Aus Gewichtsgründen können auch die eigens entwickelten Spanntürme aus Mineralguss eingesetzt werden. Diese verfügen über eine so hohe Vibrationsdämpfung, dass dadurch im oberen Bereich der Türme sehr präzise gearbeitet und dabei eine exzellente Oberflächengüte erreicht werden kann.

Basisschienen / Base rails

Masssystem / Measurement system = metric & inch powerCLAMP

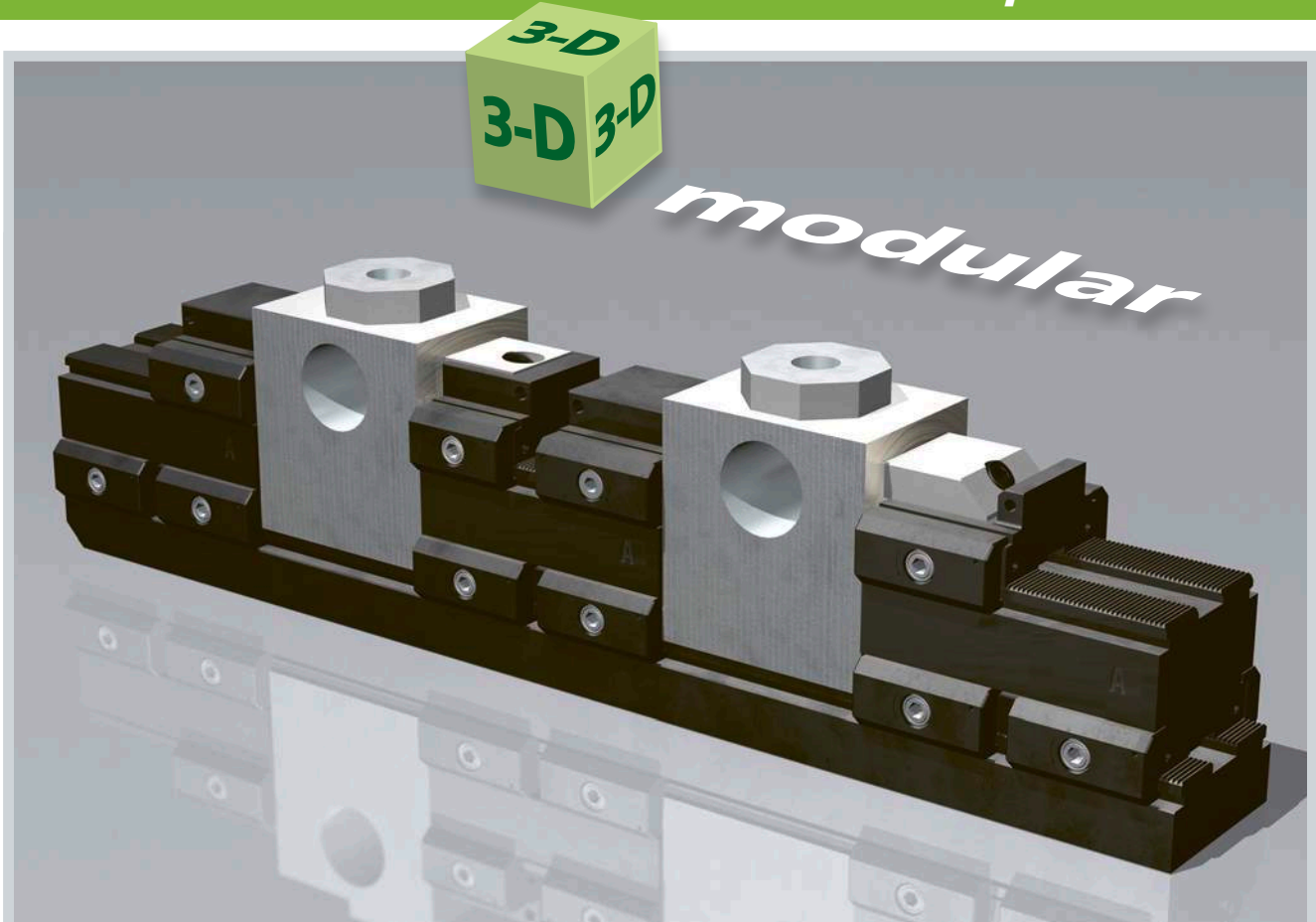

Mit verschiedenen Basismodulen kann man auch die 3. Dimension Modular gestalten! Mit der Höhe von 60 mm kann die Modulhöhe auf 94 respektive auf 109 mm erhöht werden (34/49 Modulhöhe). Die Länge von 130 mm erlaubt es jeweils ein Spannmodul und ein Anschlagmodul zu platzieren.

There are different sizes of riser blocks to increase the height of the clamp modules. This way you can get from 34 to a clamp height of 94 or 109 mm depending on the clamp module you choose. This riser blocks makes the power clamp system 3D-modular!

Mehr auf Seite | More on Page 48

Base rail

The base rail is the basic element of the Triag modular clamp system. We offer them in different lengths and heights and more than a hundred different standard clamp modules will fit onto the base rails.

Holding force which the clamp modules are clamped to the base rail is 15'000 daN (15t). The precision serration in 2mm pitch allows to fit the clamps fast and accurate.

All three dimension are modular! You can double or triple the length with coupling the rails or you can use them side words in a row. Also the height is modular (please see next page)

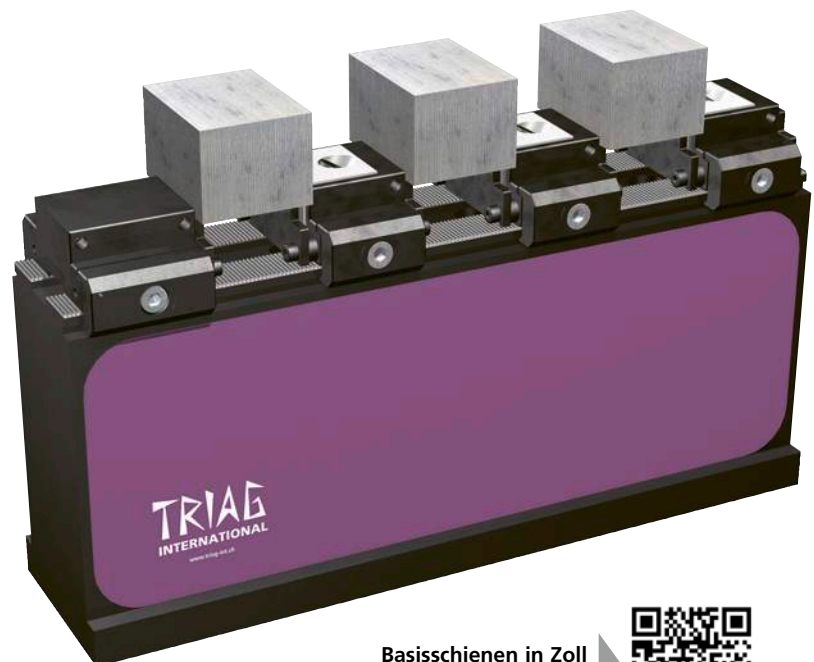

Basisschienen in Zoll
Base rails in inch



Das Anschlagmodul / End modules

Für das Spannsystem «Power Clamp» ist in der Regel nur ein Anschlagmodul als «feste Backe» notwendig. Mittels der 2 mm Verzahnung lässt sich das Modul sehr genau auf der Basisschiene positionieren und ist mit der Schraubspindel schnell befestigt.

Für die unterschiedlichen Bearbeitungssituationen steht eine Vielzahl von Ausführungen zur Verfügung. Diese unterscheiden sich in der Breite der Backen (ab 19 mm bis max. 150 mm) als auch in der Beschaffenheit der Spannflächen (glatt, geriffelt, gerillt, hartmetallbeschichtet oder mit Prägeverzahnung, mit der direkt geprägt werden kann).

In a row of parts there is usually one end module followed by the clamp modules. For all the different clamp situation we offer a wide range of different end modules from 19 mm to 150 mm.

Usually you have one side of the datum face flat and the opposite double serrated so you have two options in one. Also direct stamping end modules with a workholding step of 3 mm are available.

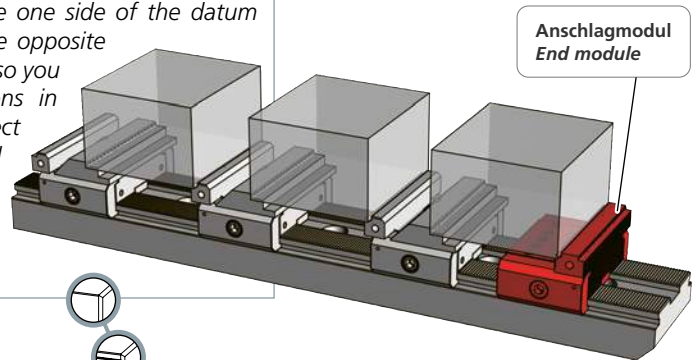

Anschlagmodul
End module

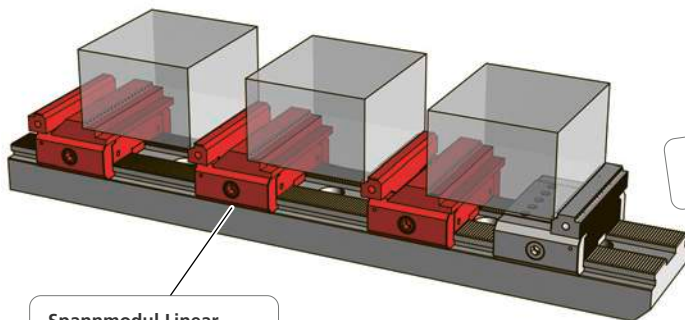

Spannmodul Linear
Linear clamping module

Verschiedene Ausführungen der Anschlagflächen!
Different styles at grip surfaces!



Lineare Direktprägespannung
Linear direct stamping module

Das Spannmodul / Clamp modules

Die «beweglichen Backen» gibt es in zwei Ausführungen. Zum einen für das Niederzugspannsystem und zum anderen für das Linearspannsystem. Dabei dient das Spannmodul bei beiden Systemen wiederum als Anschlagmodul für die nächste Aufspannung.

Die Breite der Spannfläche bewegt sich wie bei den Anschlagmodulen im Bereich zwischen 19 mm und 125 mm. Durch die innovativen Ausführungen der Spannflächen wie z. B. die Prägebacken oder Druckstifte werden enorme Haltekräfte erreicht.

Bei umfangreichen Testreihen zu der Werkstückverschiebung bei einer Spannkraft von 2000 daN und einer Zerspankraft von bis zu 600 daN wurden bei der Verwendung von Prägebacken nur minimale Abweichungen vom Nullpunkt festgestellt. Leichte Abweichungen von der Parallelität der Werkstücke werden mit der Pendelfunktion ($\pm 4^\circ$) ausgeglichen.

Innovative Lösungen gibt es auch für spezielle Spannaufgaben, wie z.B. Formbacken, Dreibacken- und Spannanzgenfutter, Vakuumplatten oder Magnetspannplatten.

There are mainly two different types of clamp modules. Linear and pull down jaws both with integrated datum face for the next workpiece. Datum face can normally be double serrated or flat.

The movable jaws you can get in various versions such as hardened flat, carbide coated soft jaws double serrated, linear pull down, direct stamping dovating and more. The width of the clamps modules starts from 19 mm up to 125 mm.

Clamping force goes to a maximum of 2800 daN (2,8t).

For special clamping situations we offer also chucks, collet chucks vacuum plates or even magnet plates which fits onto the Power Clamp base rails.

**Niederzugspannmodule
Pull down clamp modules**

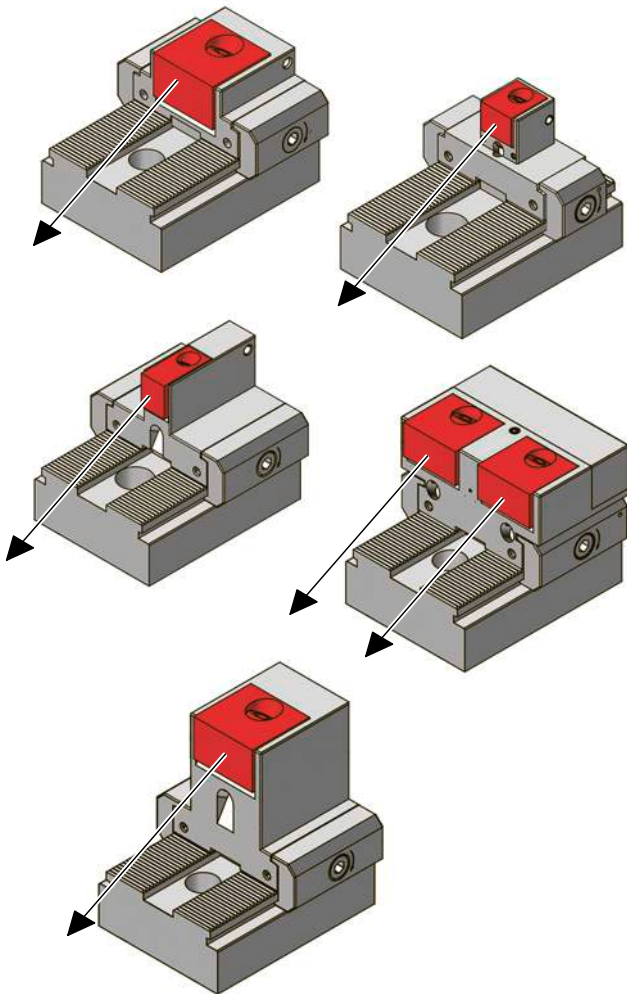

Die Fakten beim Niederzugspannsystem

Verstellbereich: 0- 4,1 mm
Spannkraft: Bis 2'800 daN

Vorteile beim Niederzugspannsystem:

- Höhere Haltekräfte
- Hohe Wiederholgenauigkeit
- Optimale Spannmethode für Kleinteile
- Mit Schnellwechselbacken
- Doppelspannsystem in einer Backe zum Spannen und Bearbeiten von zwei Kleinteilen
- Mit Vorsatz als Linearspannsystem einsetzbar
- Auch Anschläge mit Niederzugeffekt erhältlich

Facts for pull down clamp modules

Jaw range: 0- 4,1 mm
Clamping force: up to 2'800 daN

Advantages pull down jaws:

- Higher holding force
- With linear adaptable jaws
- Also with pull down jaws for the stop side available
- With adapter set can be changed to linear
- Also pull down jaws for datum face

**Linearspannmodule
Linear clamp modules**

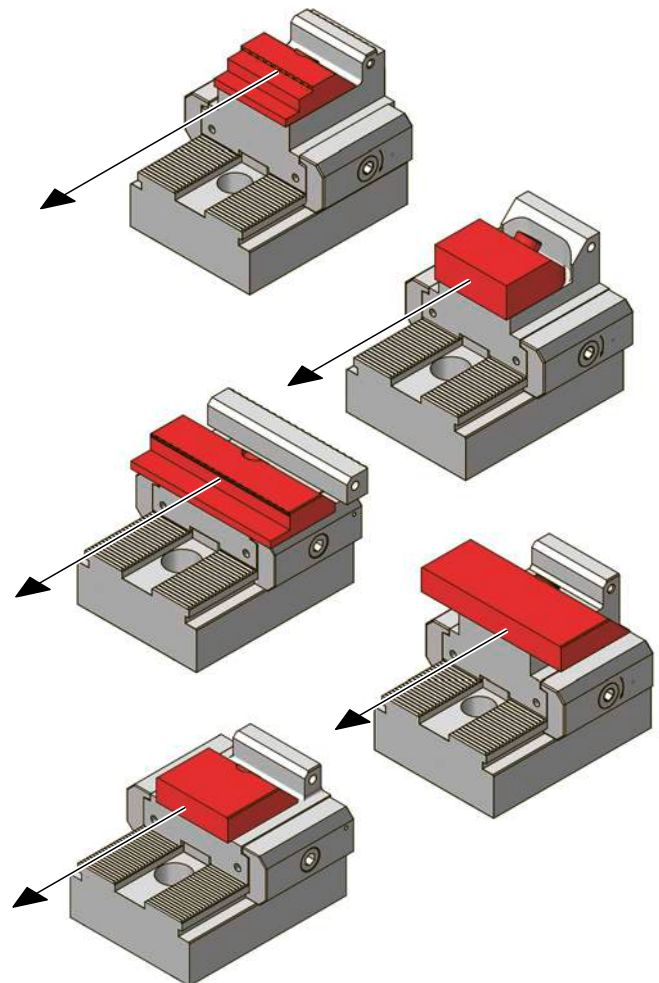

Die Fakten beim Linearspannsystem

Verstellbereich: 0- 5,0 mm
Spannkraft: Bis 1'600 daN

Vorteile beim Linearspannsystem:

- Spannstockähnliches Spannen
- Prozesssichere Positionierung der zweiten Aufspannung
- Gut geeignet für die Erstellung von individuellen Formbacken
- Sicherer Halt mit Prägetechnik

Facts for linear clamp modules

Jaw range: 0- 5,0 mm
Clamping force: up to 1'600 daN

Advantages linear jaws:

- Similar clamp as conventional vise
- Good for shaped jaws
- Secure clamped with direct stamping jaws
- Higher accuracy

ACHTUNG / CAUTION

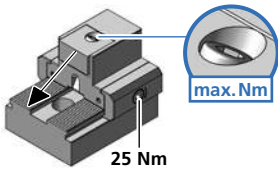

Niederzug Spannmodule
Pull adown module

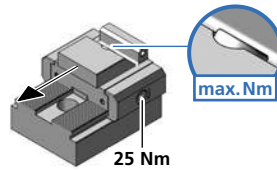

Linear Spannmodule
Linear module



| Schraube / Screw | Drehmoment / Torque | | Spannkraft / Workholding force | | | |
|------------------|---------------------|---------|--------------------------------|--------|------|------|
| | Nm | (lb-ft) | ~daN | ~(lb) | ~t | |
| M5 + M6 | 4 | 3 | = 500 | 1100 | 0,50 | |
| | 5 | 3,7 | = 580 | 1280 | 0,58 | |
| | 6 | 4,4 | = 690 | 1520 | 0,69 | |
| | 7 | 5,2 | = 780 | 1720 | 0,78 | |
| | 8 | 5,9 | = 880 | 1940 | 0,88 | |
| | 9 | 6,6 | = 980 | 2160 | 0,98 | |
| | 10 | 7,4 | = 1020 | 2250 | 1,02 | |
| | 12 | 8,9 | = 1220 | 2690 | 1,22 | |
| | M6 | 14 | 10,4 | = 1450 | 3200 | 1,45 |
| | | 15 | 11 | = 1520 | 3350 | 1,52 |
| 4 | | 3 | = 410 | 900 | 0,41 | |
| M8 | 5 | 3,7 | = 490 | 1080 | 0,49 | |
| | 6 | 4,4 | = 560 | 1230 | 0,56 | |
| | 7 | 5,2 | = 660 | 1450 | 0,66 | |
| | 8 | 5,9 | = 730 | 1600 | 0,73 | |
| | 9 | 6,6 | = 810 | 1790 | 0,81 | |
| | 10 | 7,4 | = 900 | 1980 | 0,90 | |
| | 15 | 11 | = 1520 | 3350 | 1,52 | |
| | 20 | 14,8 | = 1810 | 3990 | 1,81 | |
| | 25 | 18,4 | = 2100 | 4630 | 2,10 | |
| | M10 | 10 | 7,4 | = 400 | 880 | 0,40 |
| 20 | | 14,8 | = 1400 | 3090 | 1,40 | |
| 30 | | 22,1 | = 2000 | 4410 | 2,00 | |
| 40 | | 29,5 | = 2800 | 6170 | 2,80 | |

| Schraube / Screw | Drehmoment / Torque | | Spannkraft / Workholding force | | |
|------------------|---------------------|---------|--------------------------------|-------|-----|
| | Nm | (lb-ft) | ~daN | ~(lb) | ~t |
| M8 | 10 | 7,4 | = 400 | 880 | 0,4 |
| | 20 | 14,8 | = 800 | 1760 | 0,8 |
| | 30 | 22,2 | = 1200 | 2650 | 1,2 |
| | 40 | 29,6 | = 1600 | 3530 | 1,6 |

WICHTIG: Die angegebenen Drehmomente sind die absoluten Maximalwerte. Über die Spannkraften geben die Tabellen Auskunft.

IMPORTANT: The torque numbers specified represent the absolute maximum. The table at the bottom of this page provides further information on the workholding forces.

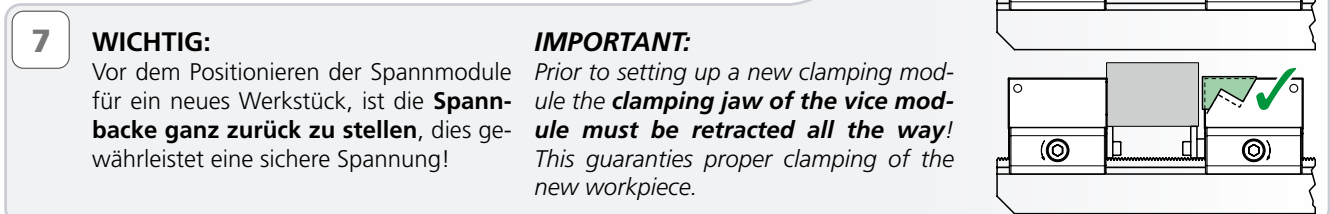
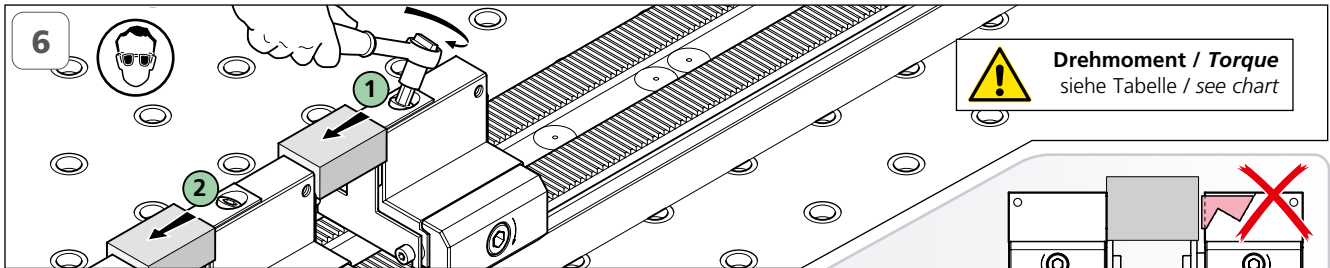
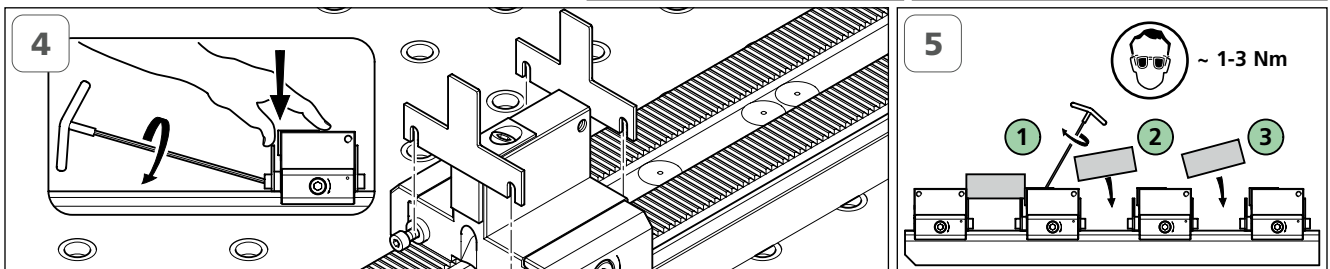
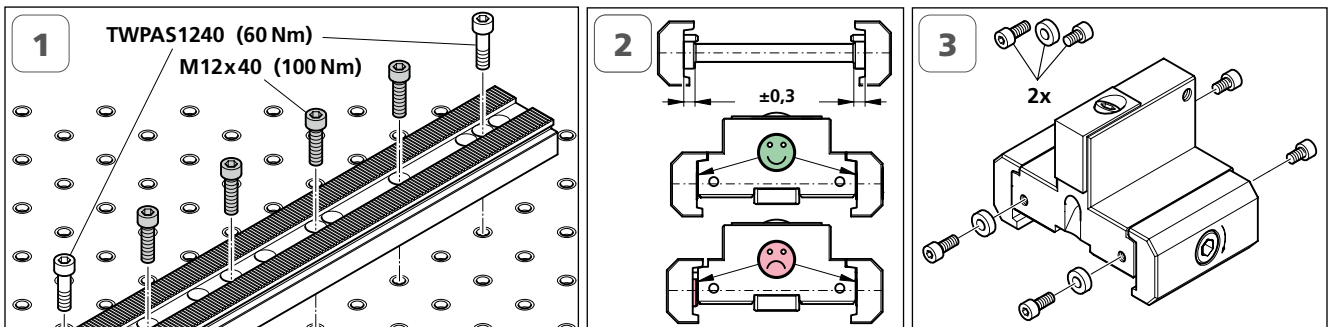

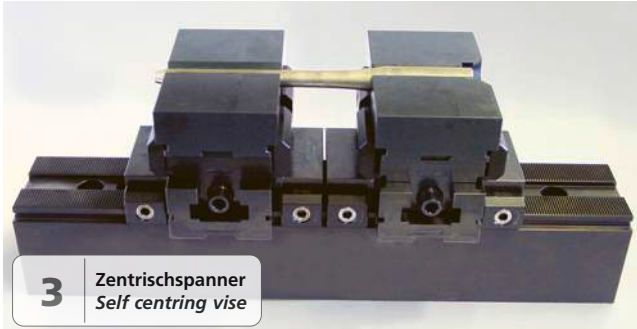
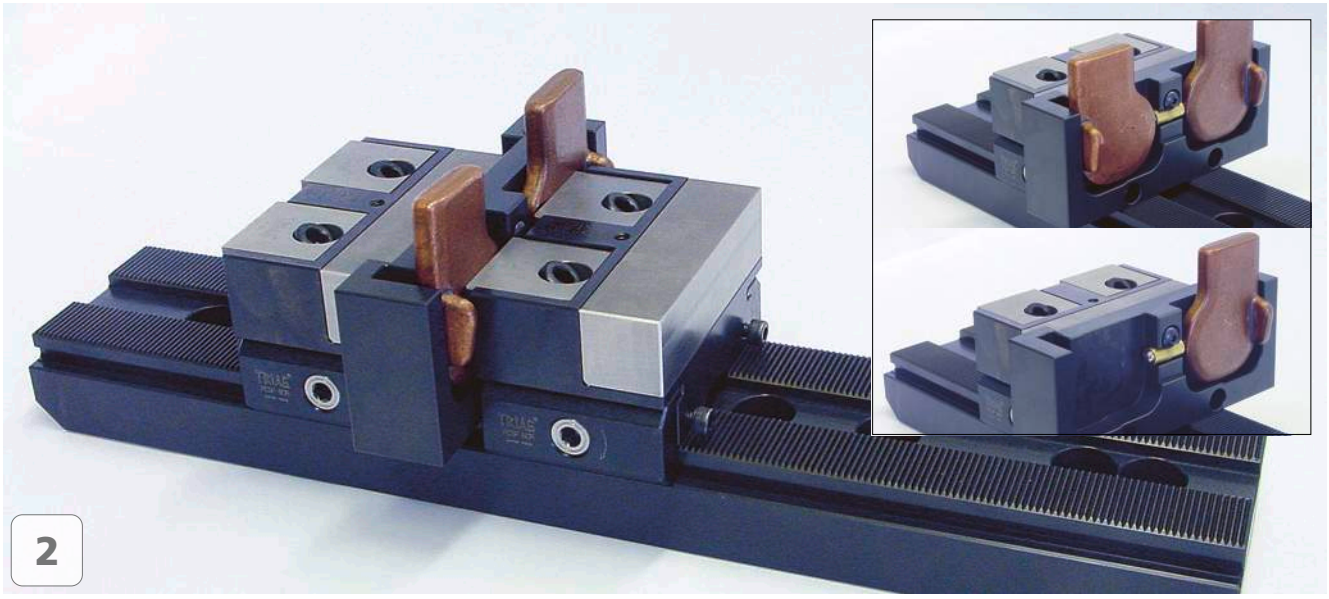
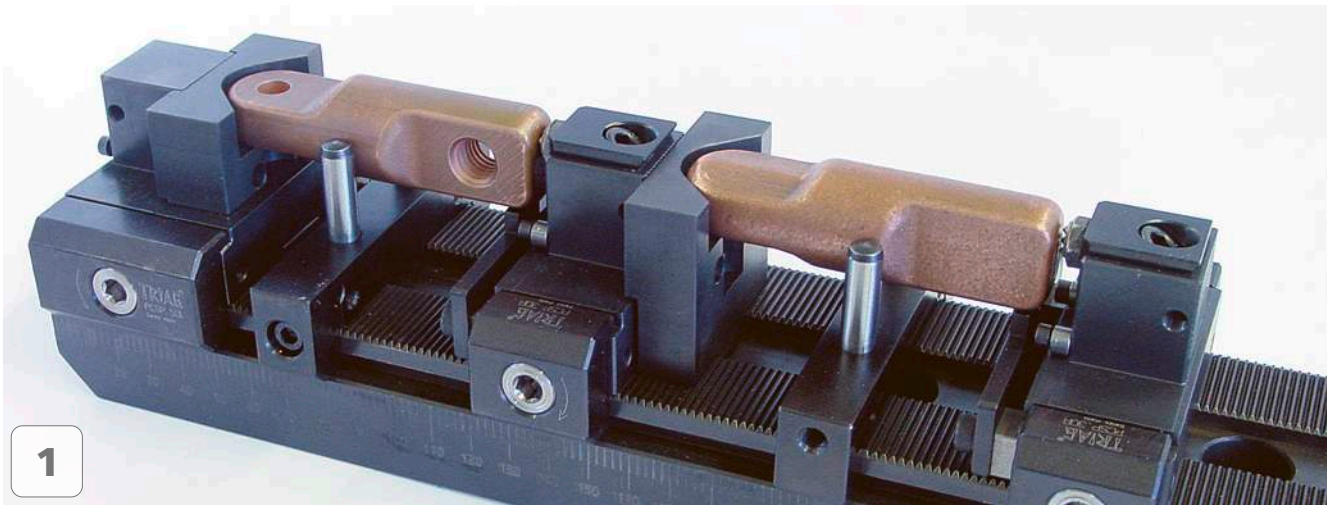

Zentrischspanner
Self centring vise

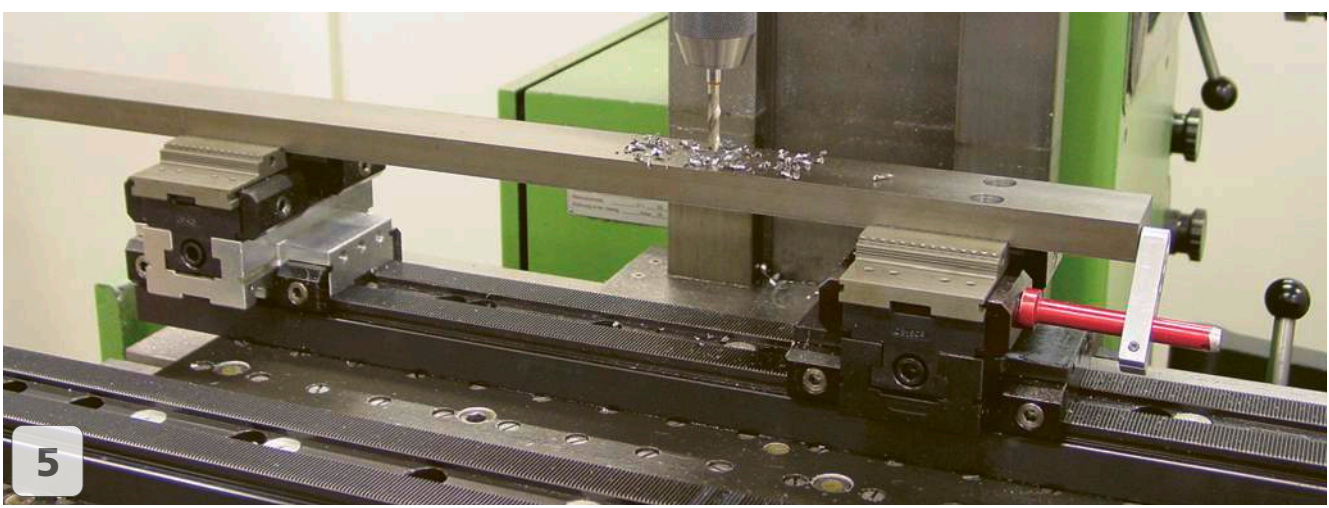

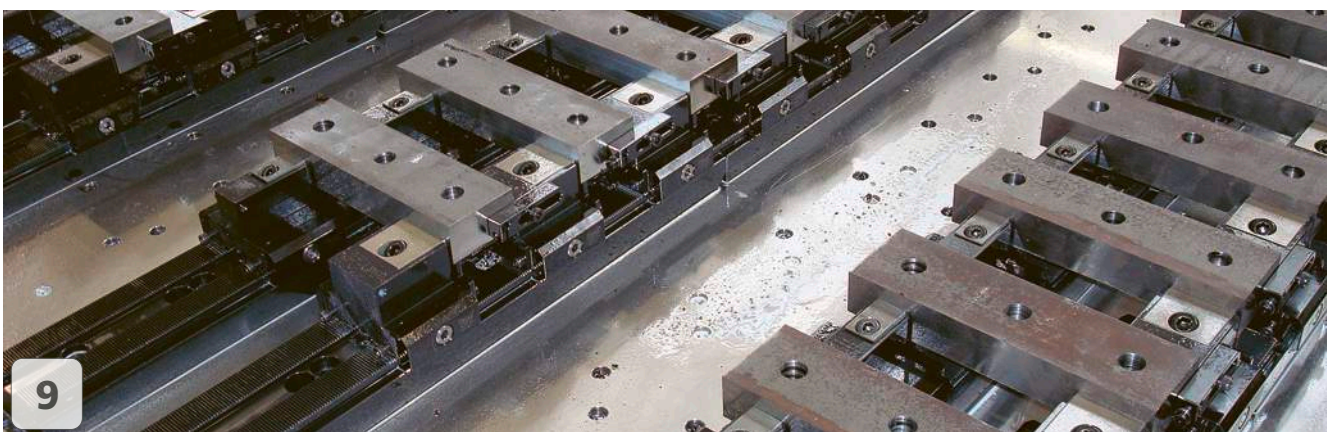
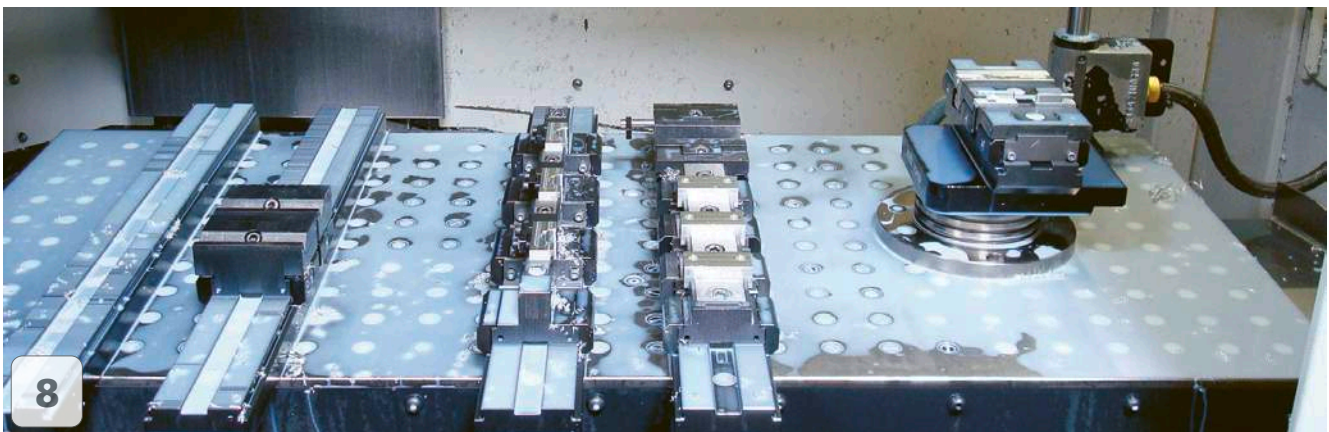
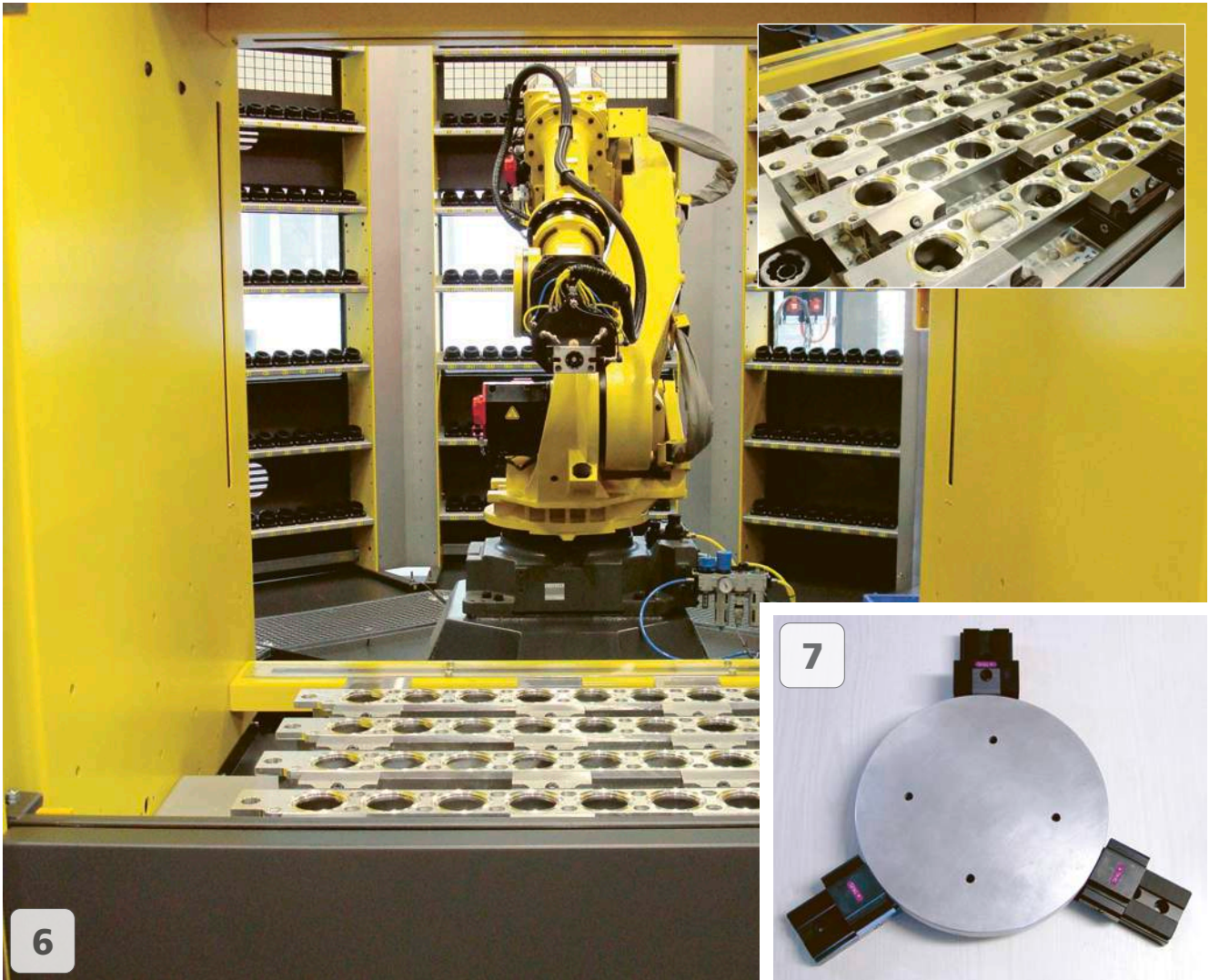

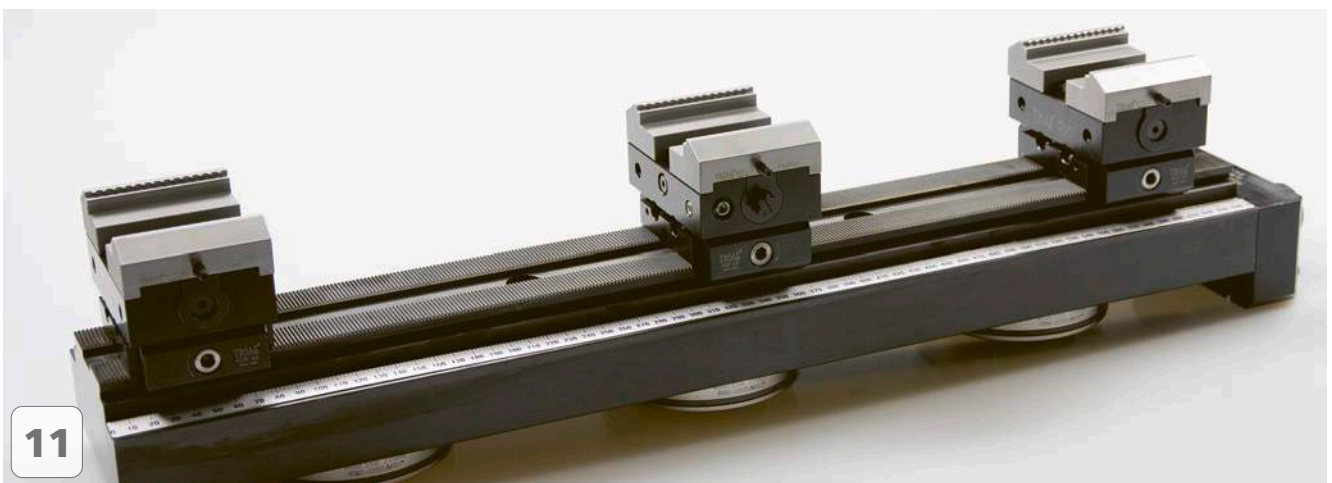
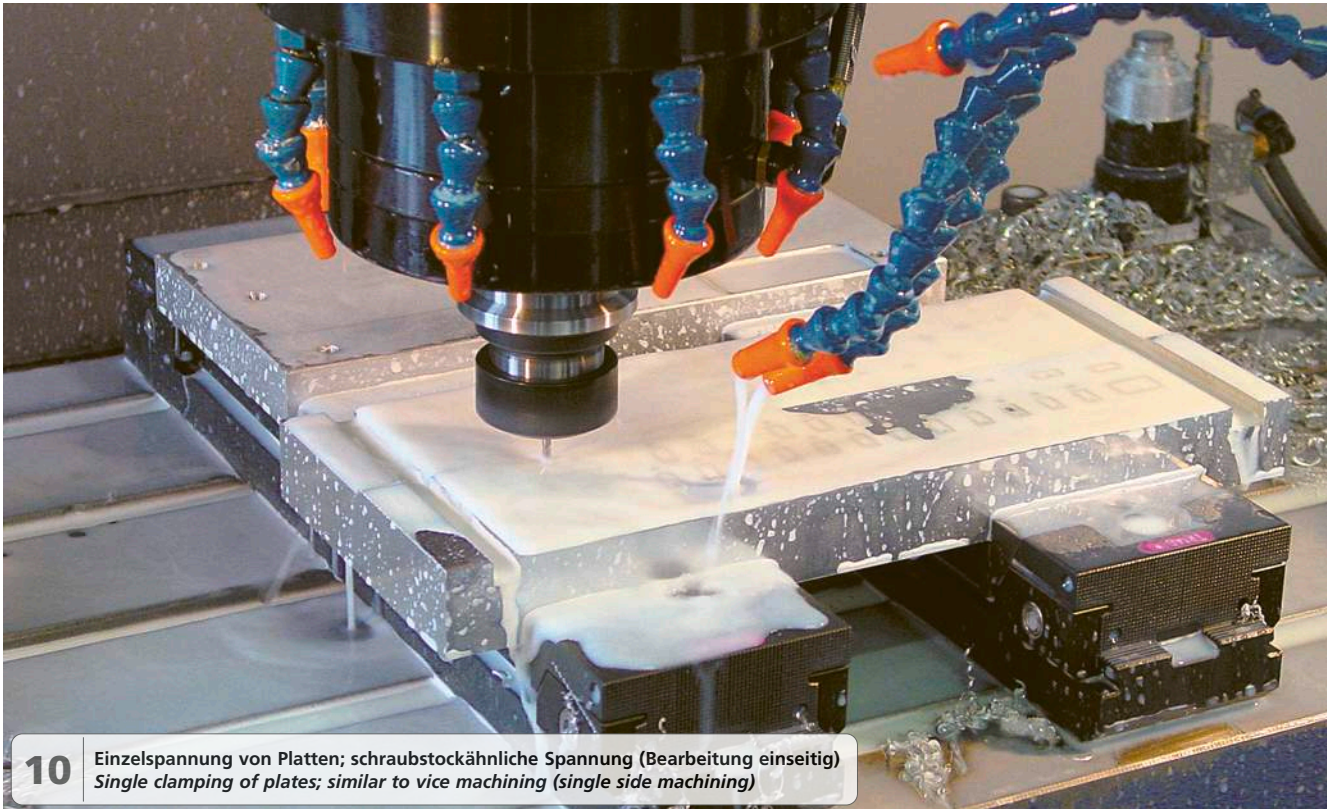

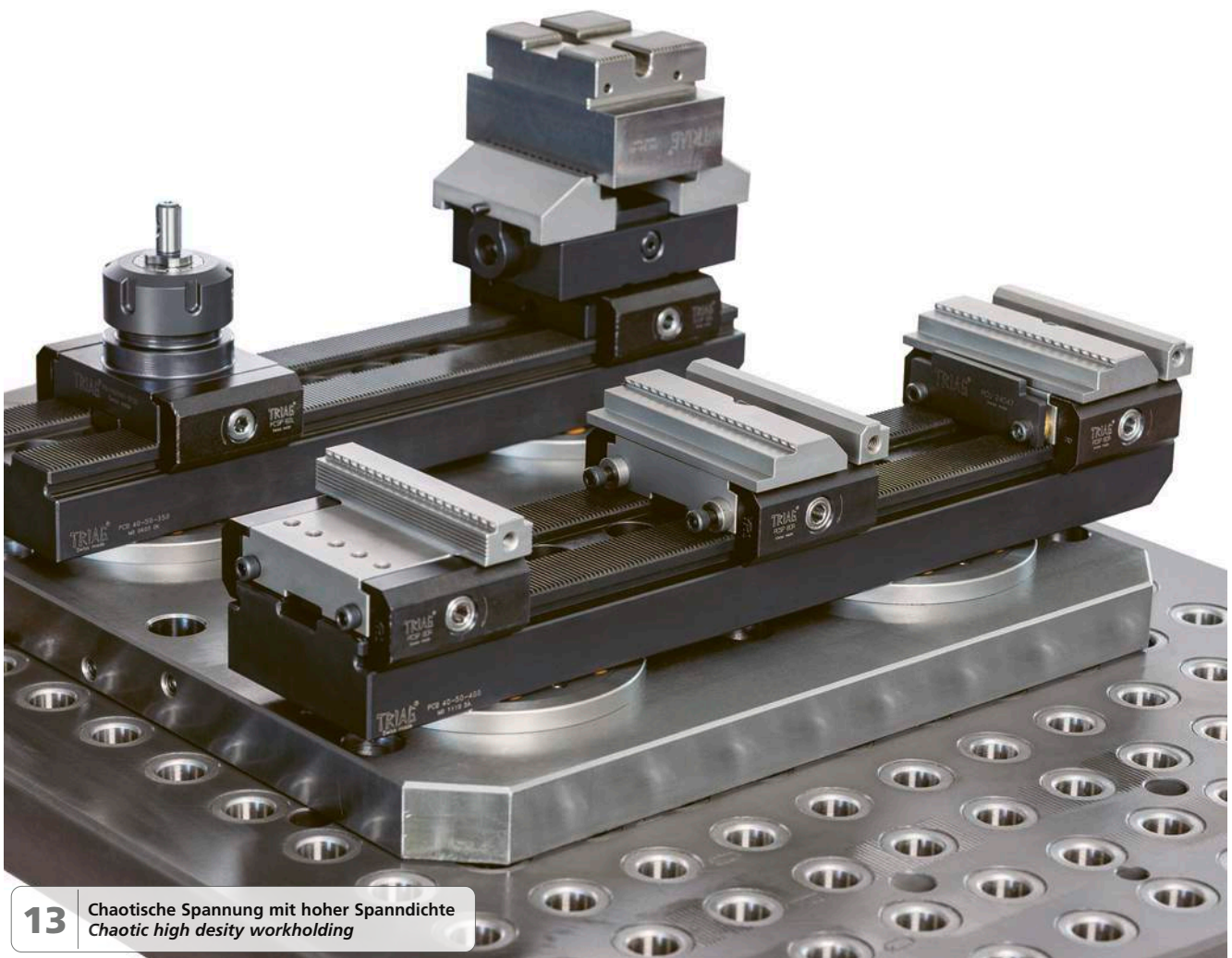

13 Chaotische Spannung mit hoher Spanndichte
Chaotic high density workholding

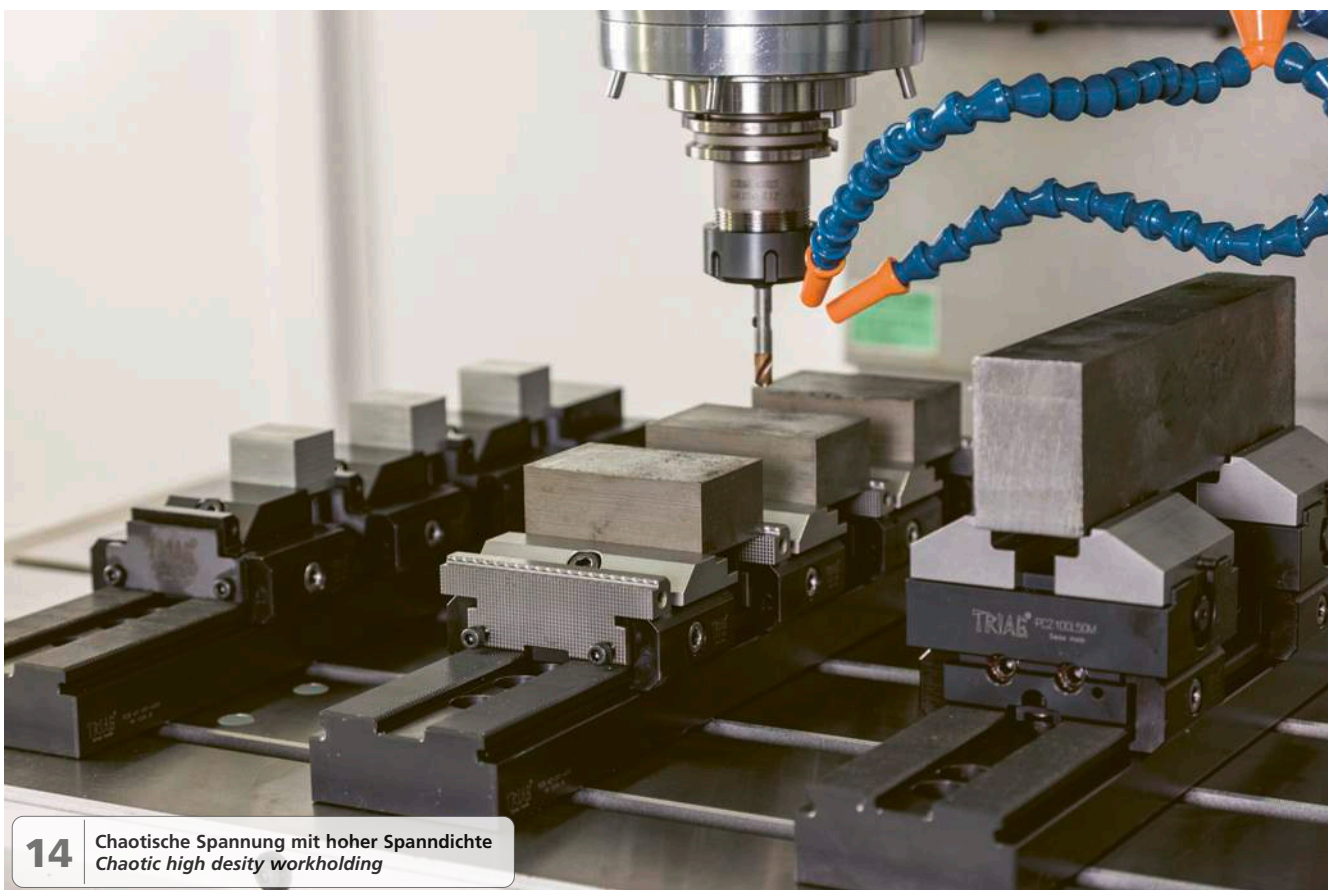

14 Chaotische Spannung mit hoher Spanndichte
Chaotic high density workholding

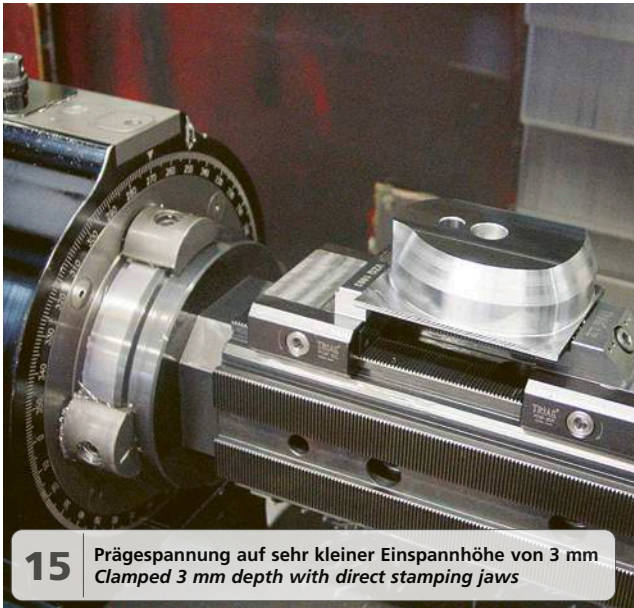

15 Prägespannung auf sehr kleiner Einspannhöhe von 3 mm
Clamped 3 mm depth with direct stamping jaws

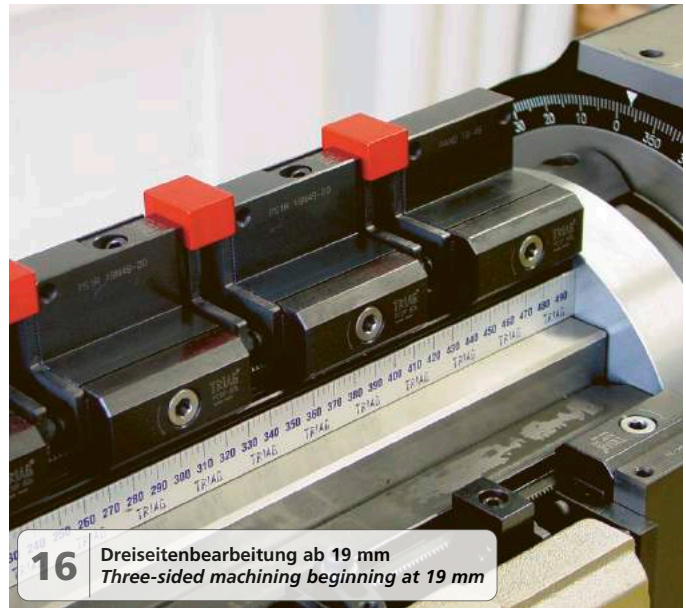

16 Dreiseitenbearbeitung ab 19 mm
Three-sided machining beginning at 19 mm



17 ... im Einsatz auf der 4. Achse
... in action on the 4th axis



18 Das Triag Power Clamp im Einsatz als Spannstock (Starterset)
Triag Power Clamp in action as machine vise (starter set)

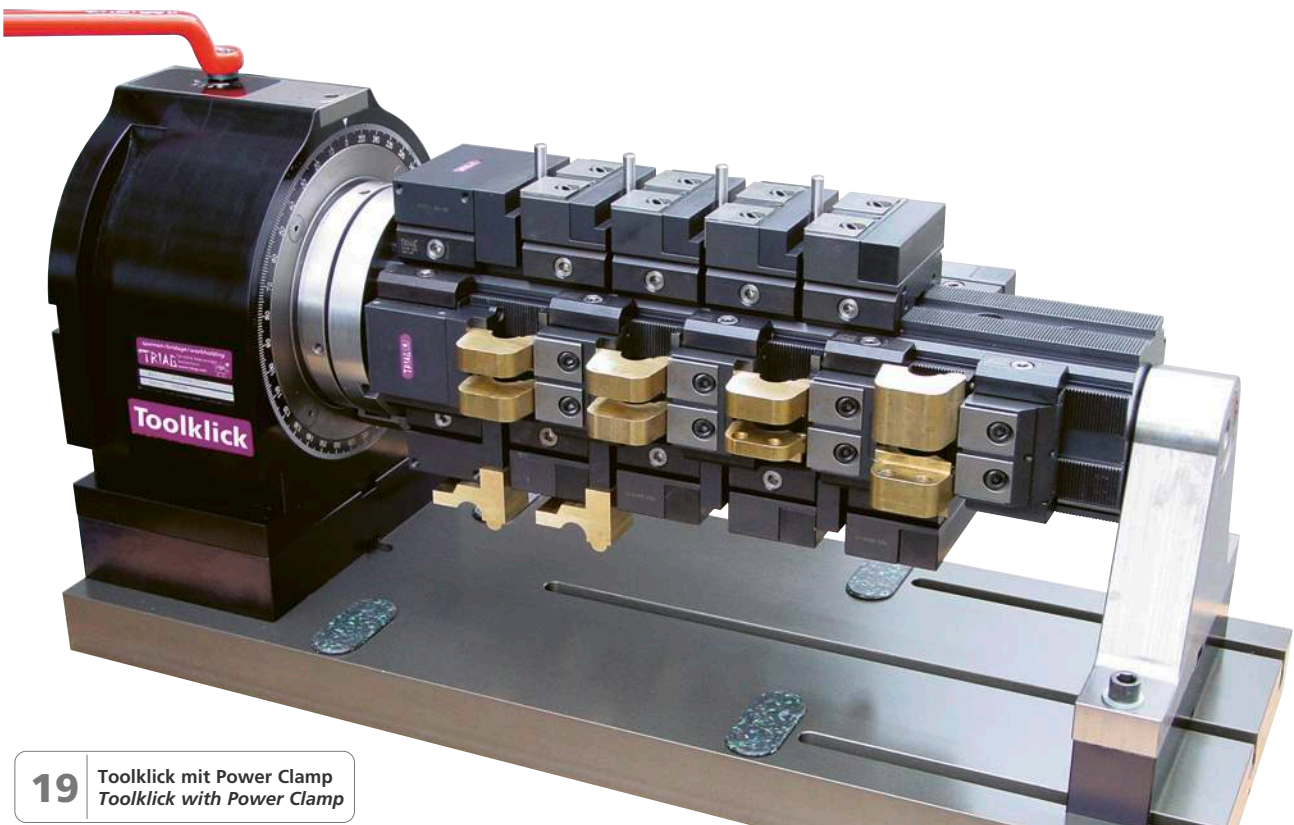

19 Toolclick mit Power Clamp
Toolclick with Power Clamp

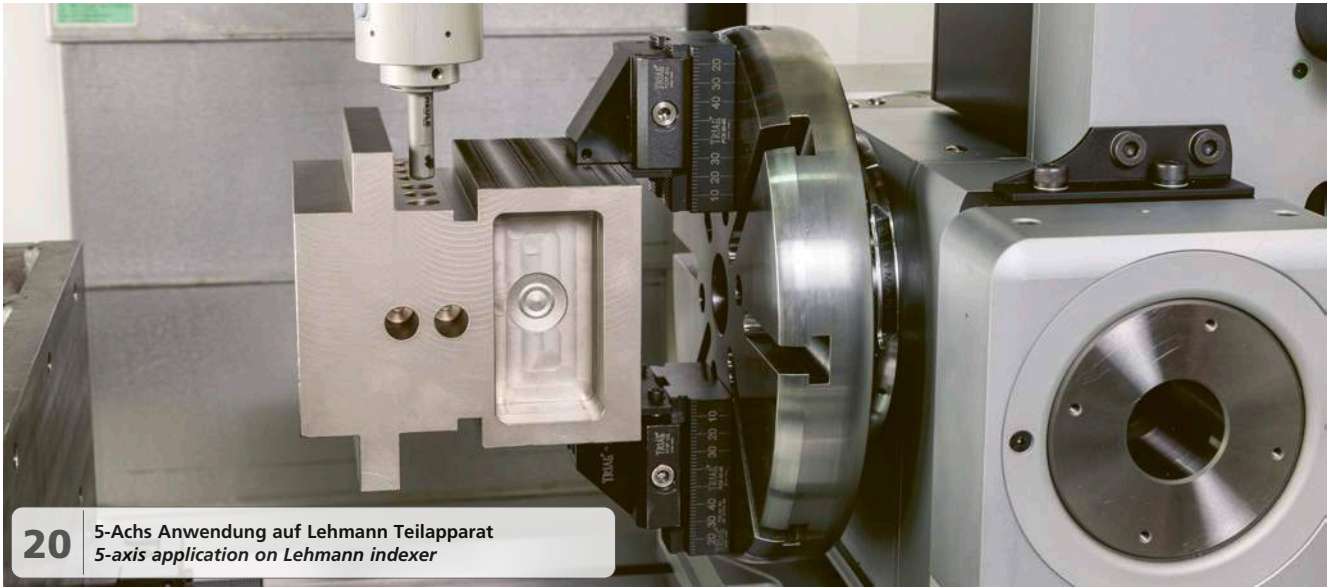

20 5-Achs Anwendung auf Lehmann Teilapparat
5-axis application on Lehmann indexer



21

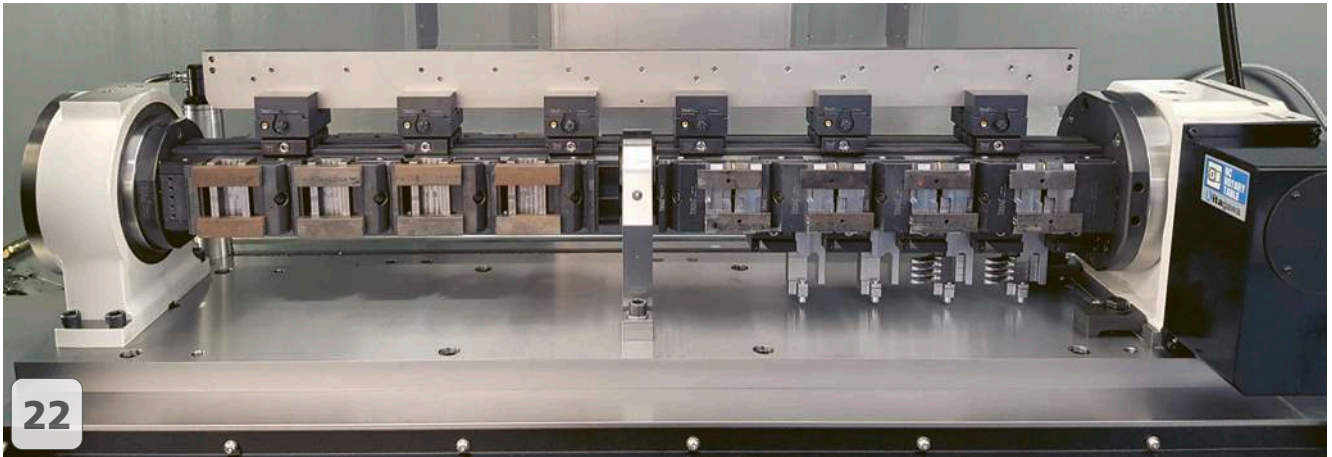

22

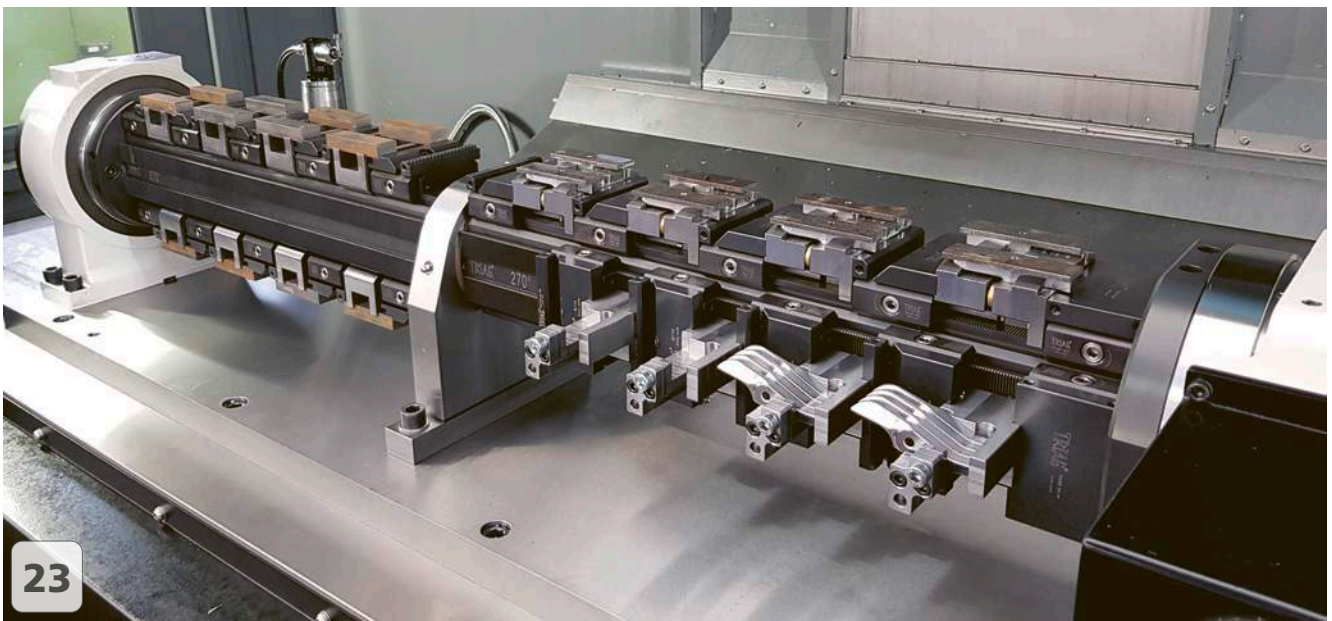

23

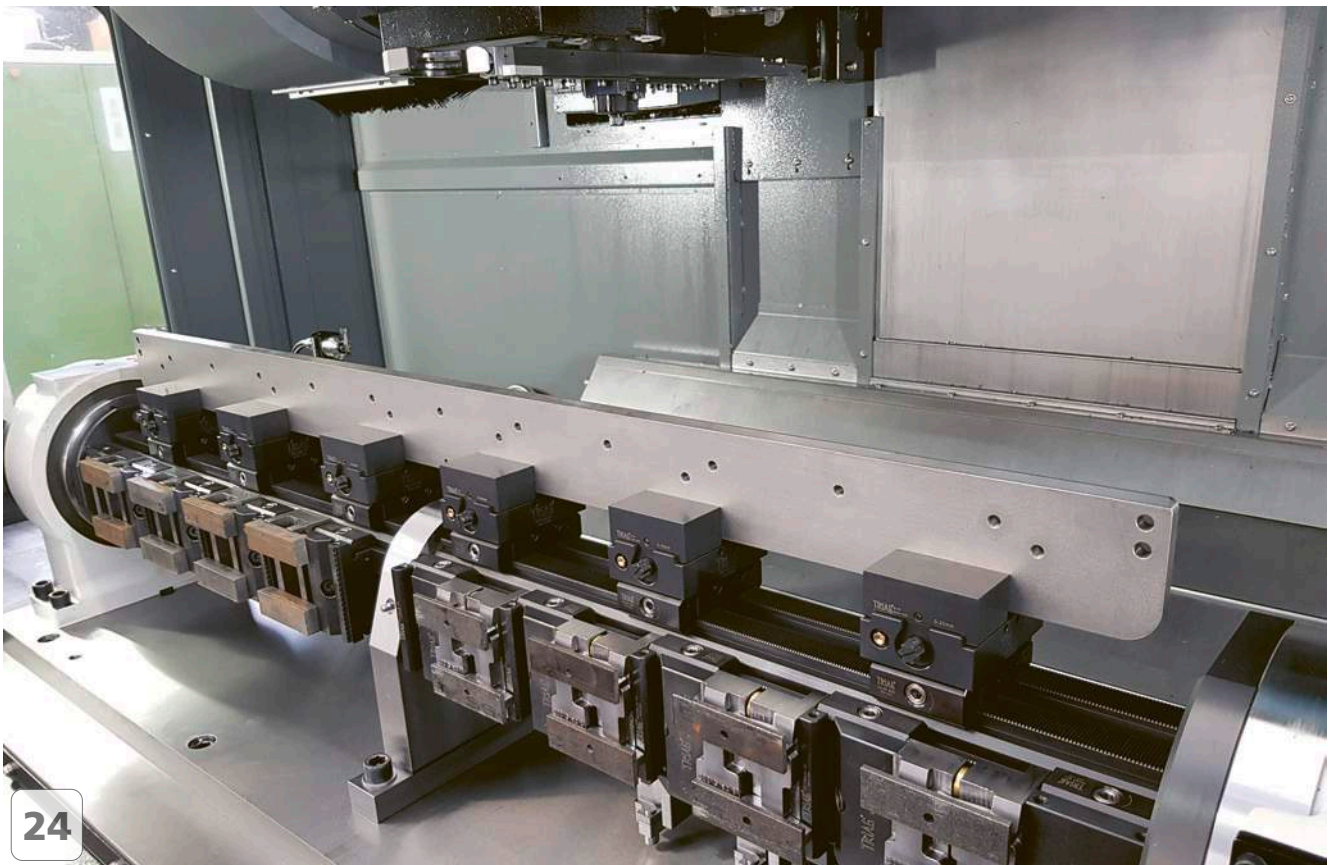

24

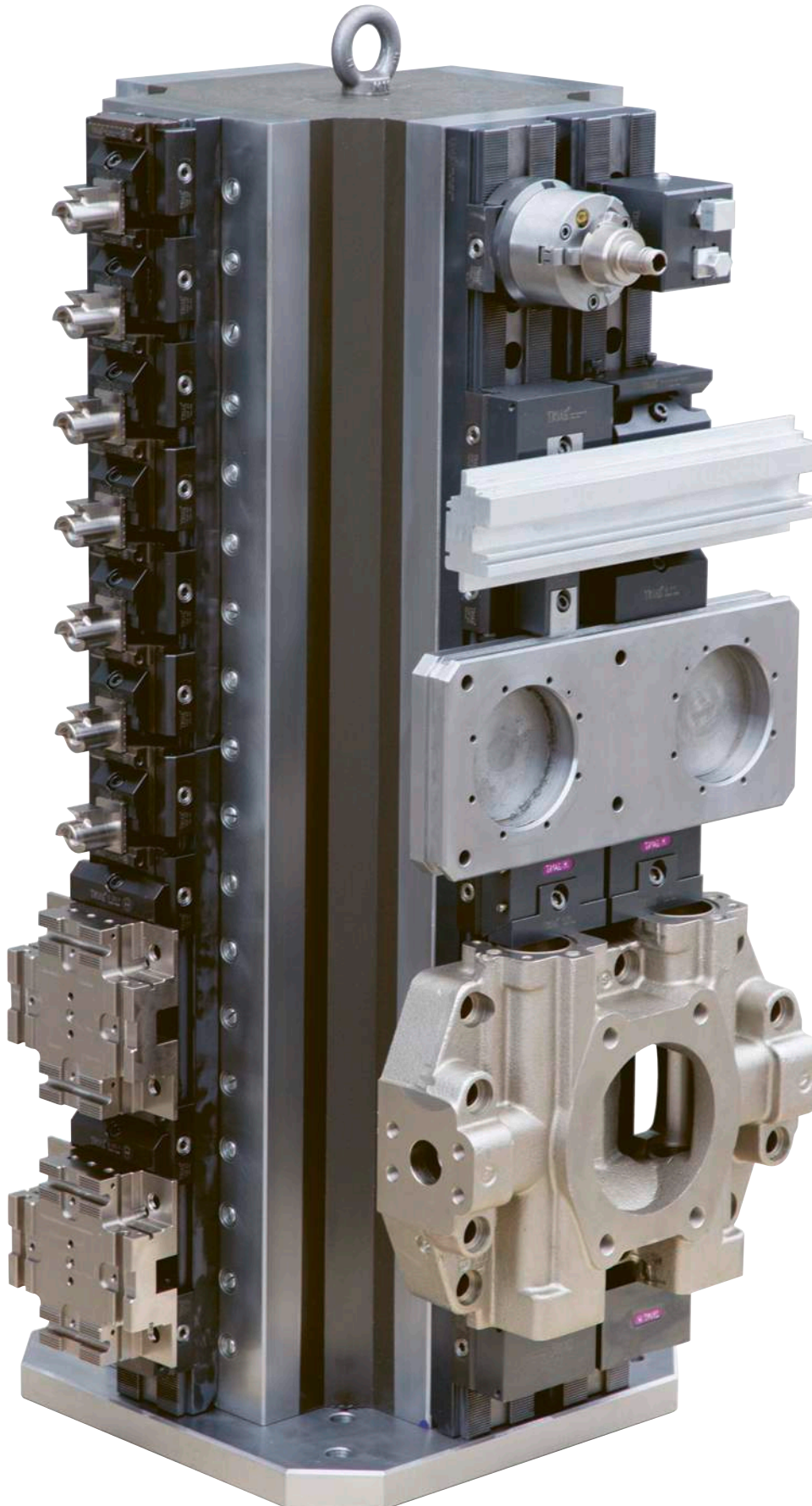

25 tripoxyMINERAL Kreuzturm mit PowerCLAMP Schienen für chaotische Spannung
tripoxyMINERAL Cross version with PowerCLAMP baserails for chaotic workholding

31 tripoxyMINERAL mit unterschiedlichen Werkstücken bestückt
tripoxyMINERAL tombstones holding a variety of workpieces



32 Zentrischspanner auf einem Spezialturm
Centric vices installed on a special tombstone

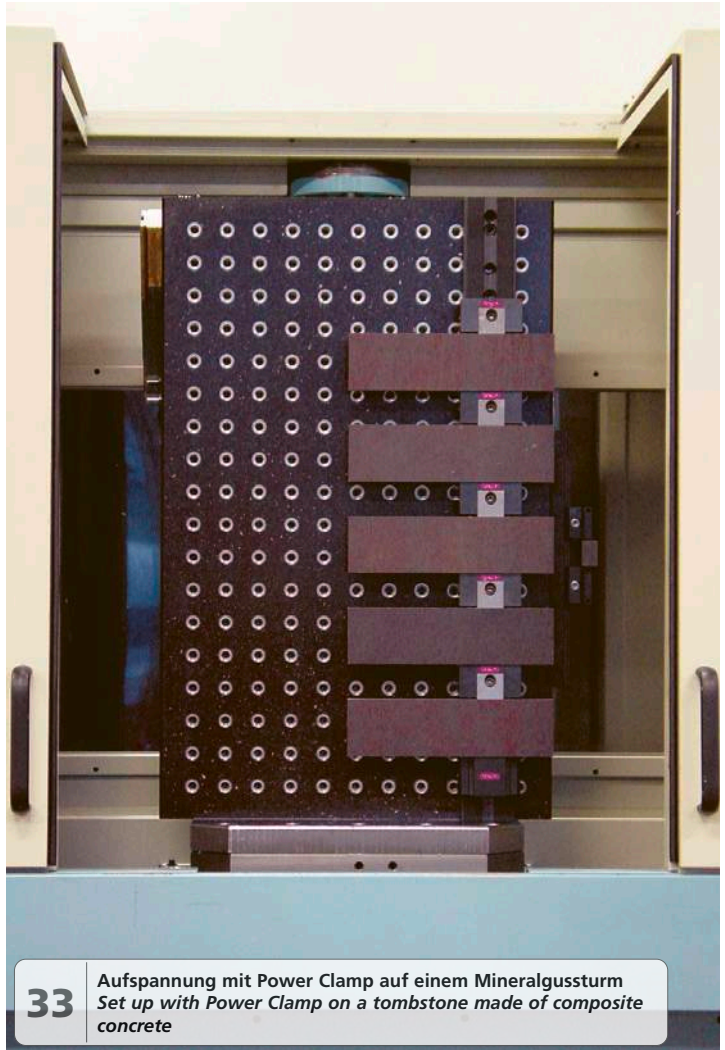

33 Aufspannung mit Power Clamp auf einem Mineralgussturm
Set up with Power Clamp on a tombstone made of composite concrete

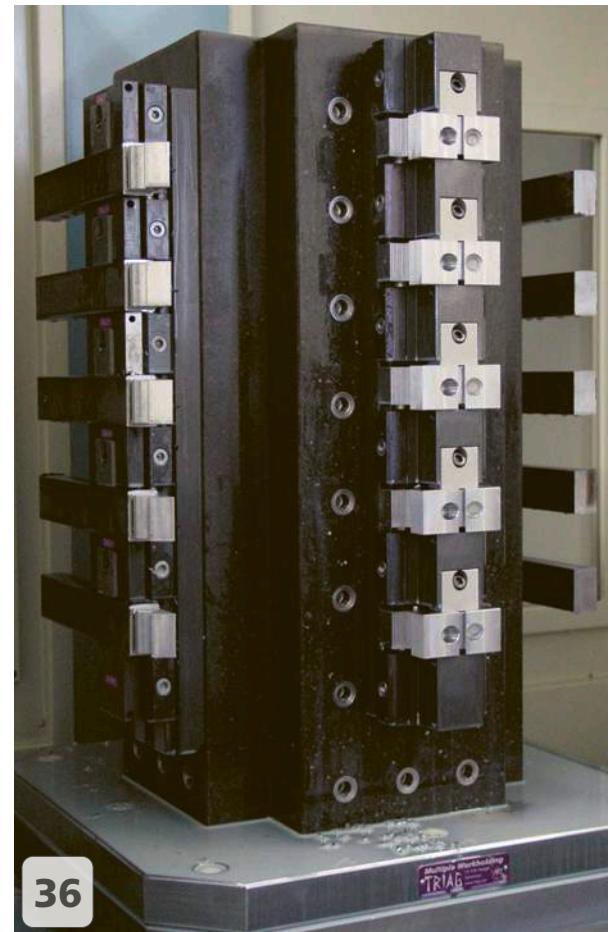
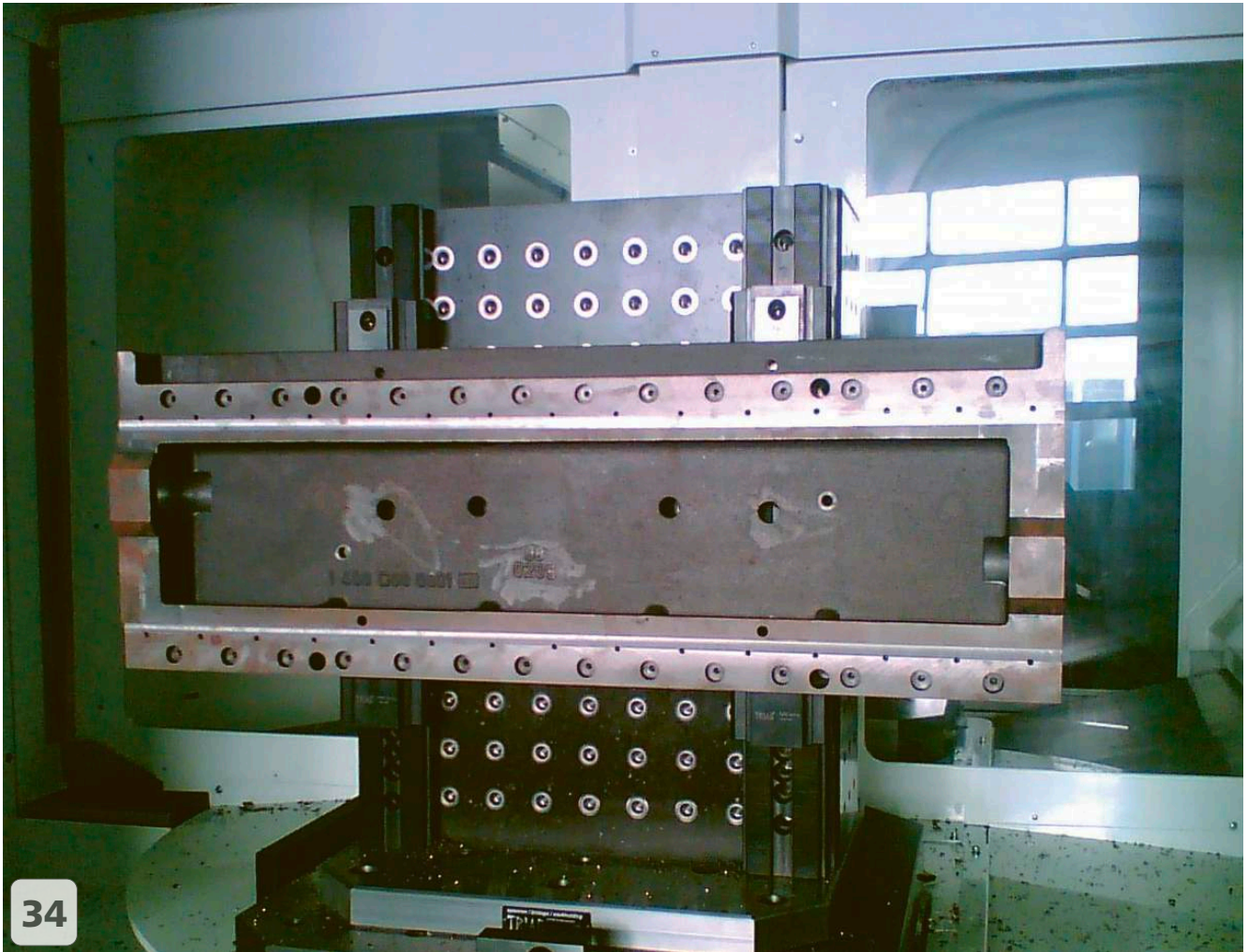

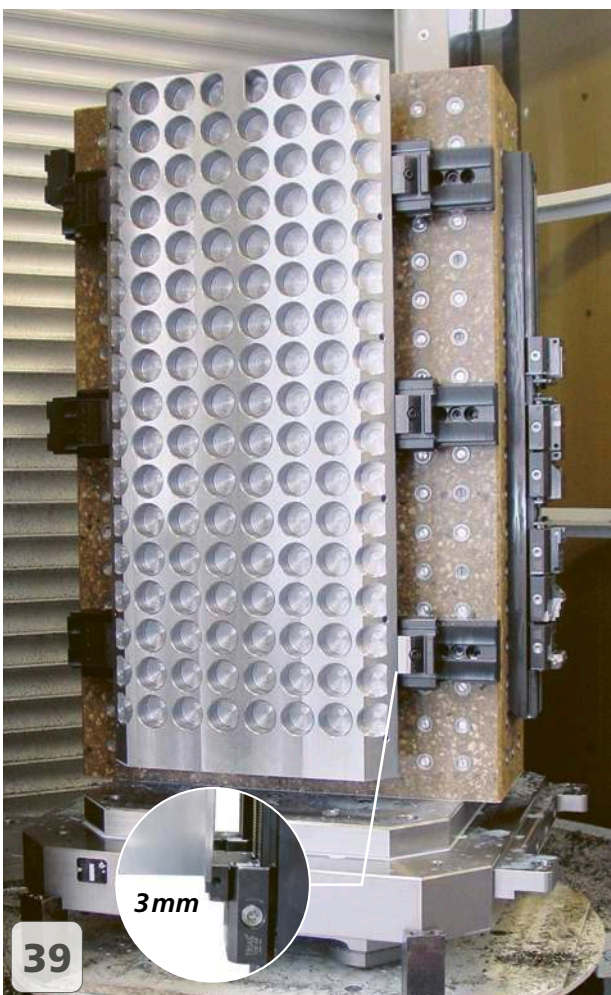
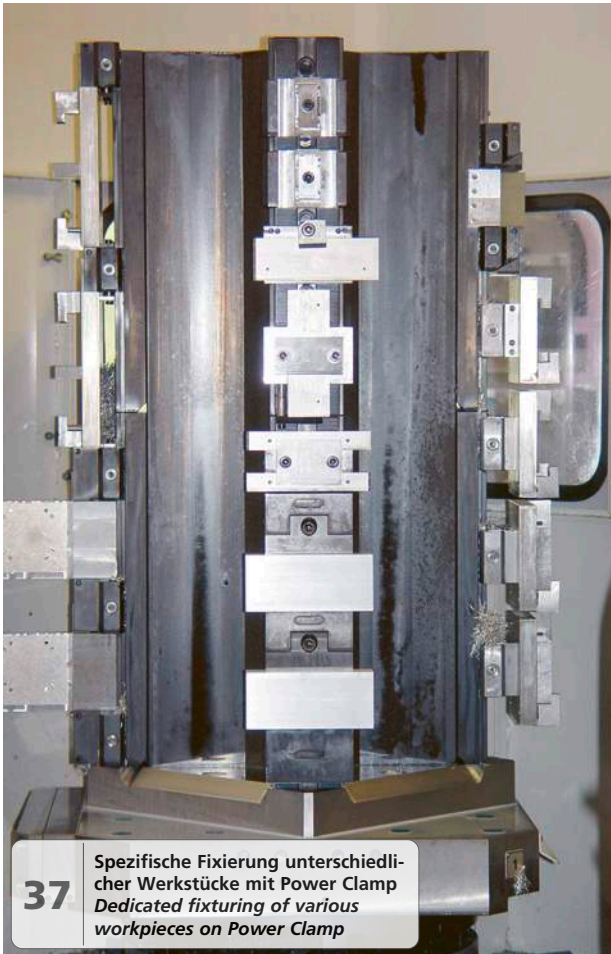

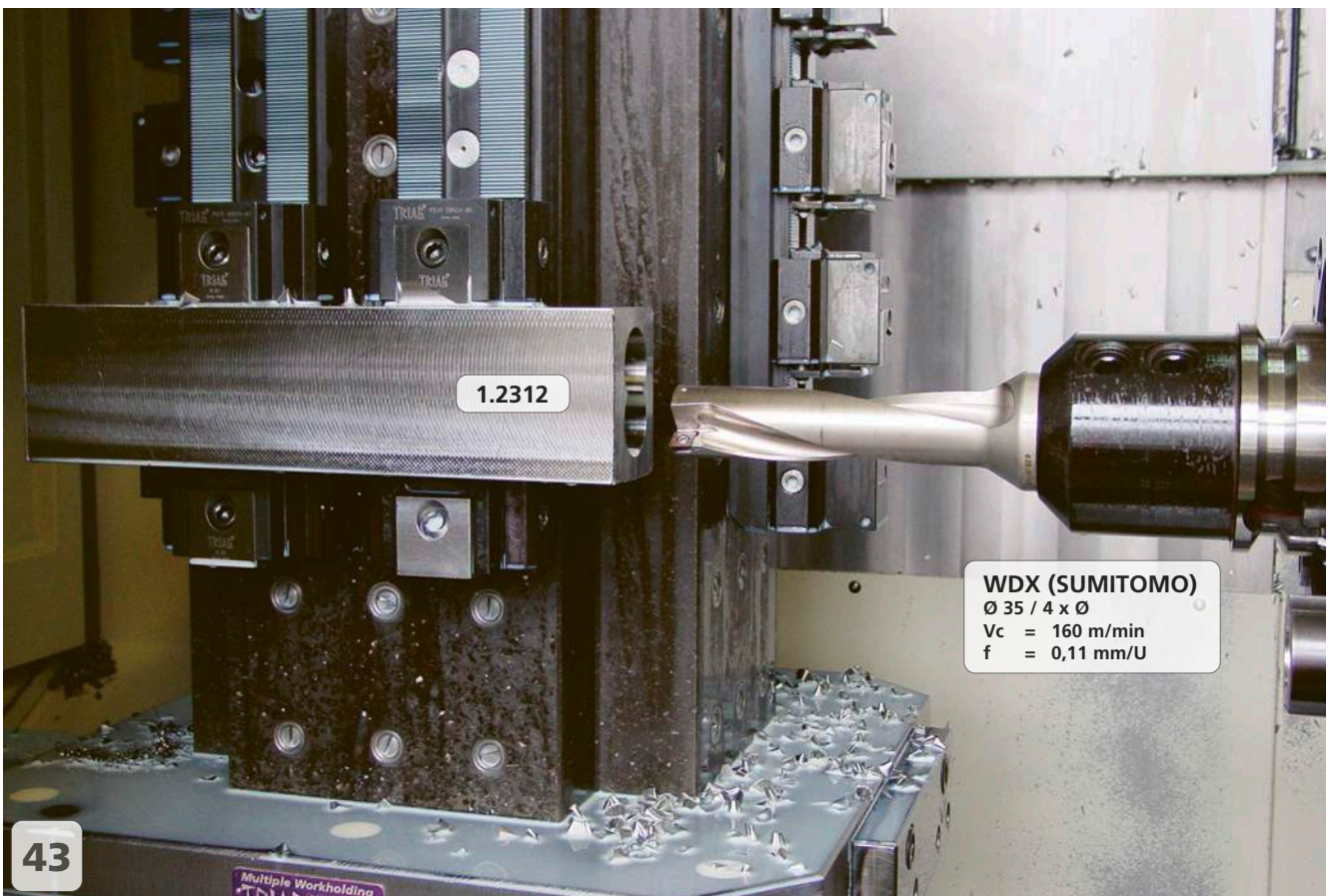
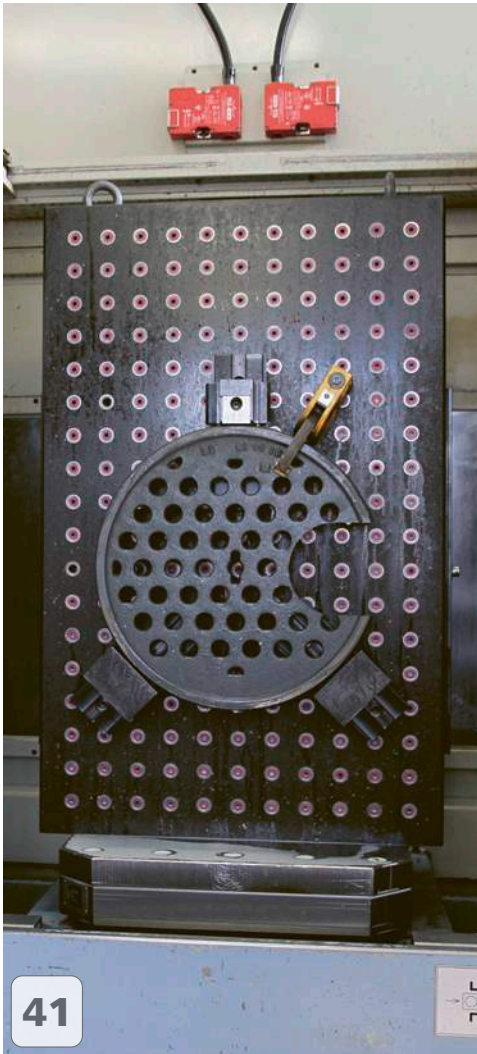



200 x 400 x 1330
Flügelteil für Airbus A320
Tail wing part for Airbus A320

45
Stahlmineralguss-Säulen mit Power Clamp für die Fertigung von Flügelteilen.
Steel epoxy frames machining wing parts on a Makino machine

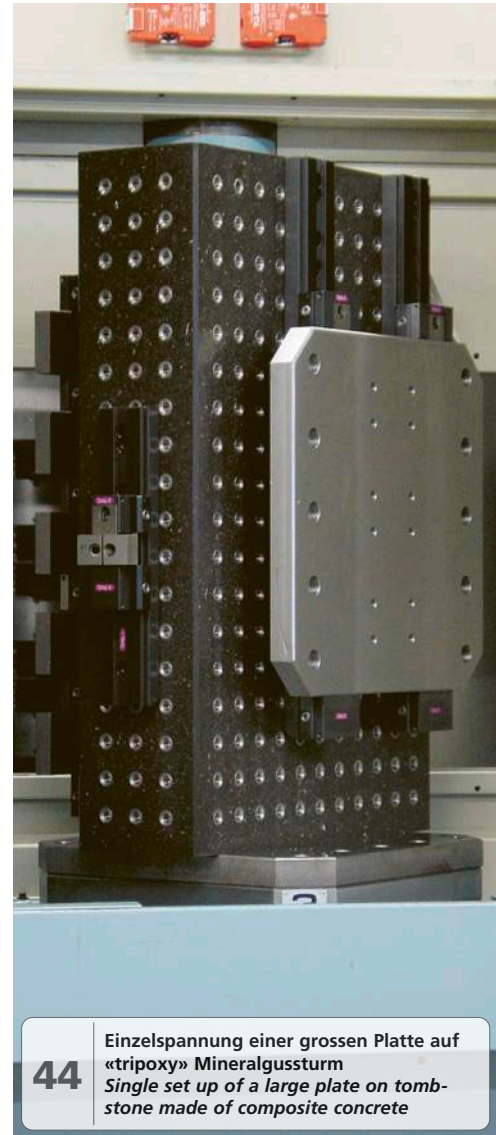

44
Einzelspannung einer grossen Platte auf «tripoxy» Mineralgussturm
Single set up of a large plate on tombstone made of composite concrete



46

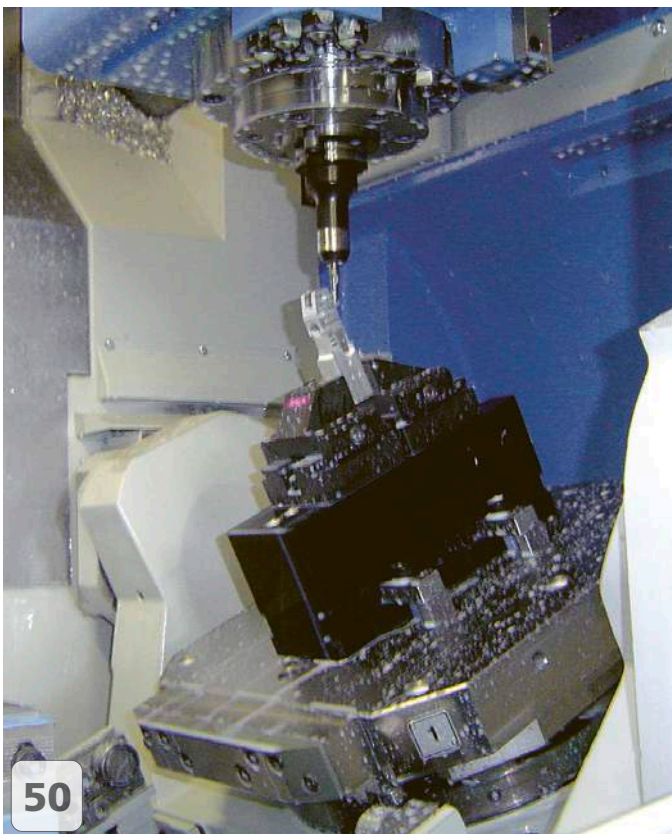
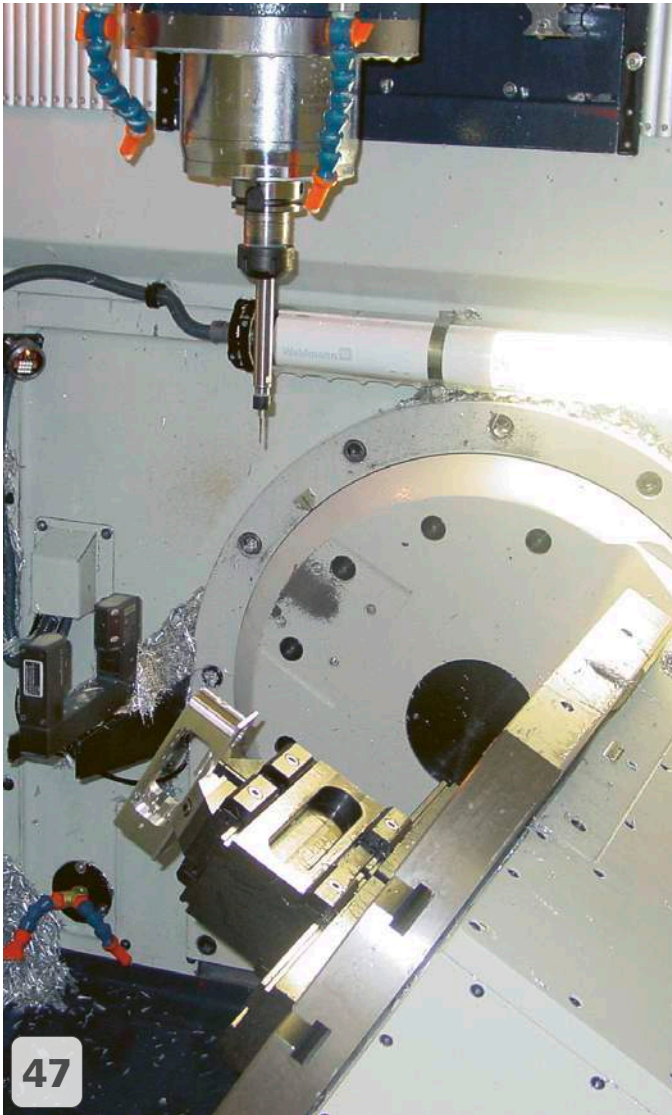

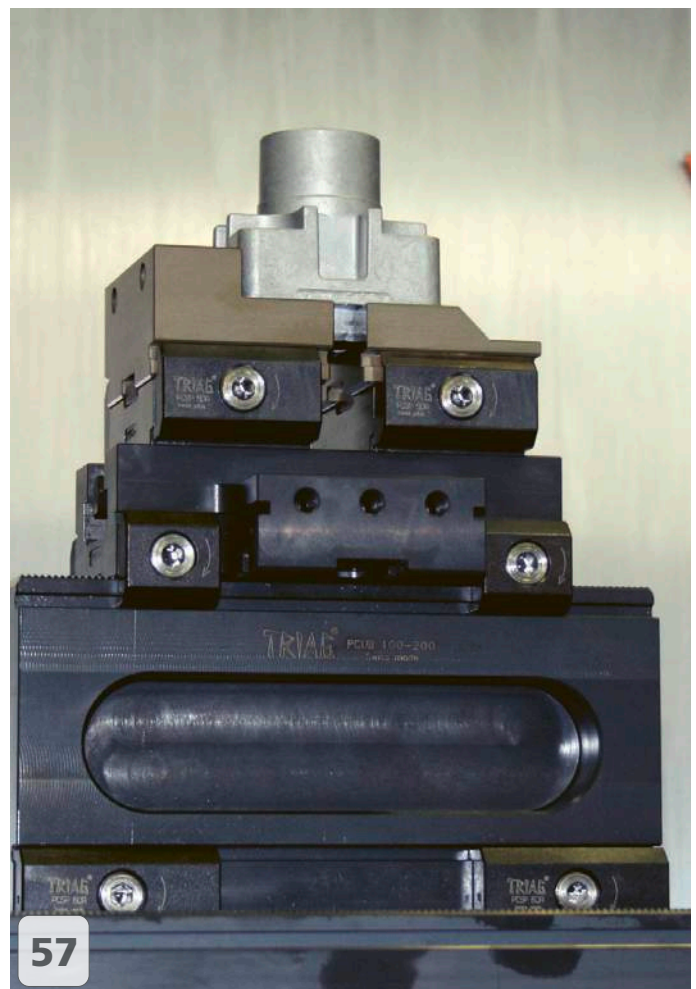
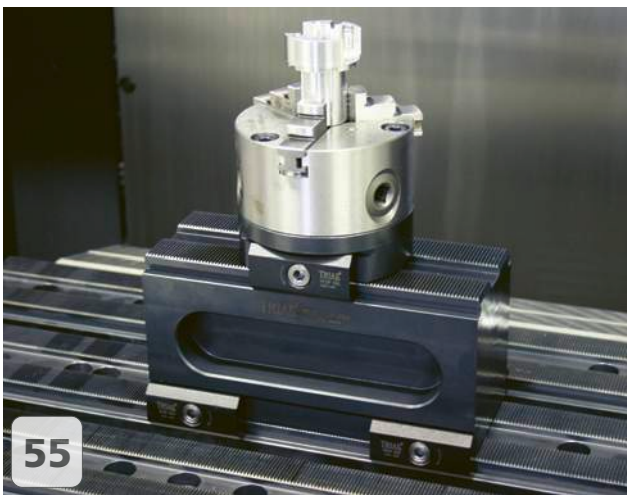
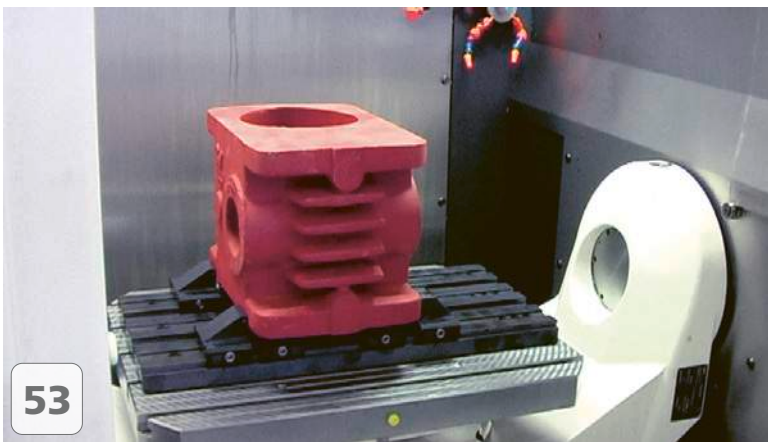

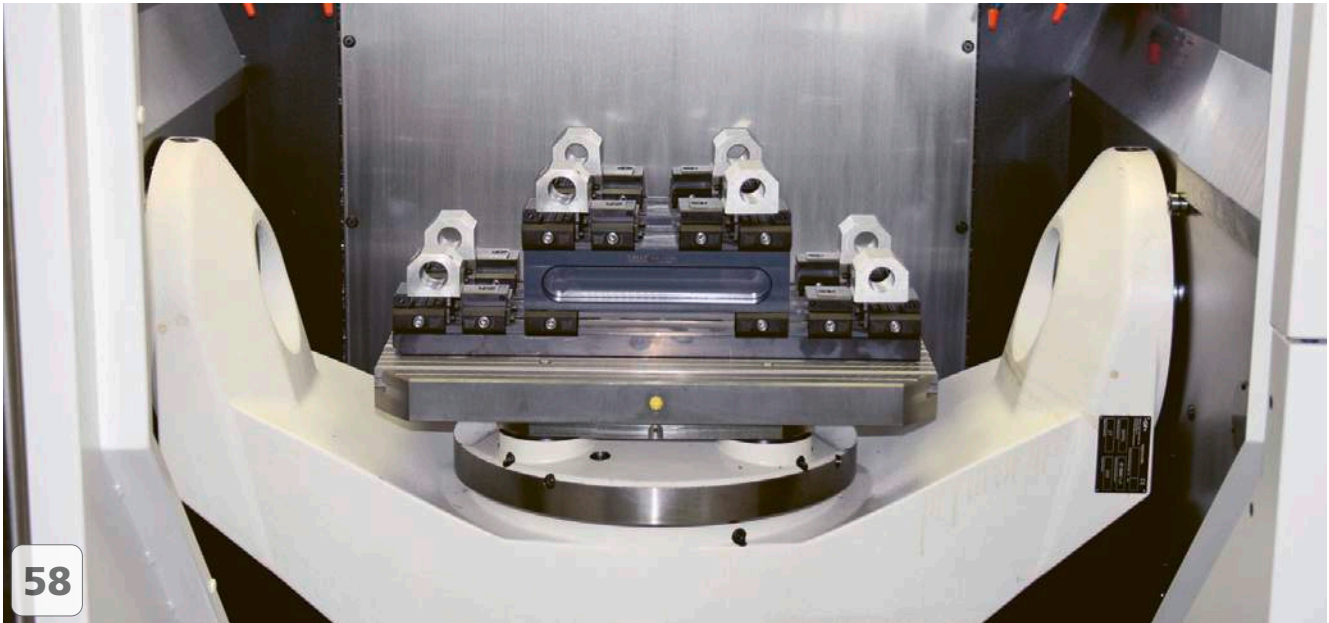

58



59

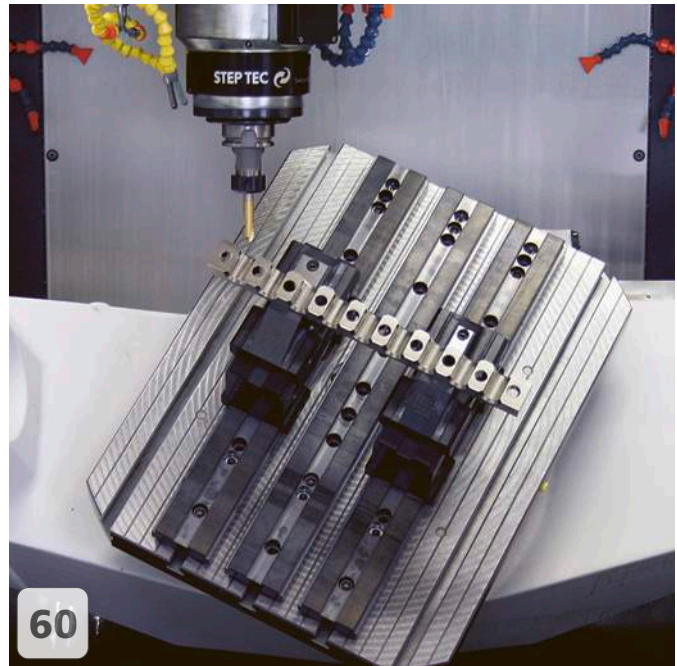

60



61

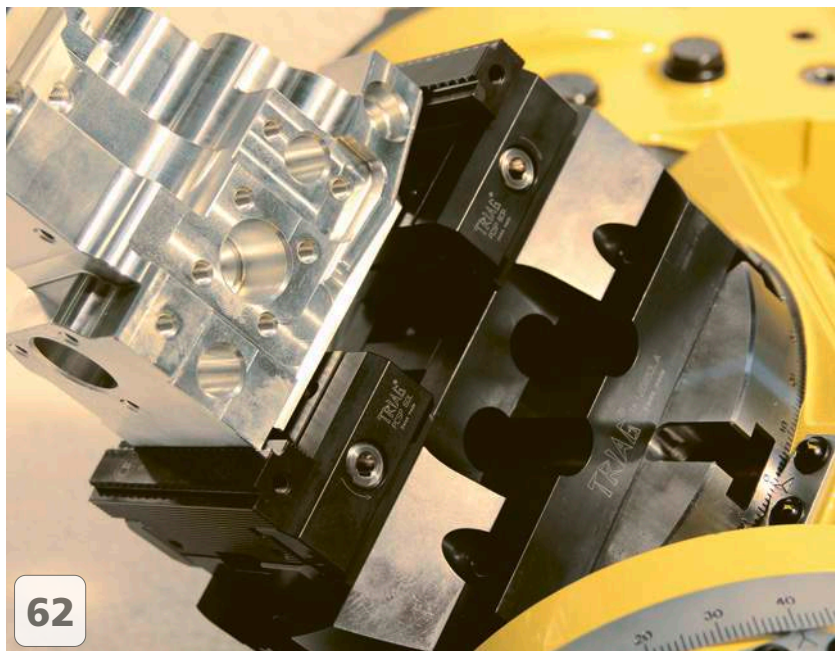

62

Modulares Mehrfachspannen auf 5-Achsen-Maschinen

Immer öfter werden die 5-Achsen-Maschinen in den Produktionsabläufen eingesetzt, um den Ansprüchen der heutigen effizienten Herstellung gerecht zu werden und weltweit wettbewerbsfähig zu bleiben. Die Werkstückspannung ist sehr anspruchsvoll und fordert die technischen Mitarbeiter ausserordentlich, wie auf den nachfolgenden Bildern dargestellt.

Modular workholding system for 5-axis machines

Increasingly, the 5-axis machines are used in the production processes to be in accordance with the demands of today's efficient manufacturing and remain globally competitive. The workpiece clamping is very demanding and calls for extremely technical staff, as shown on the following pictures.

Vorteile der Triag 5-Achsen Spannsysteme:

- Die unteren Basisschienen dienen sowohl als mechanisches Nullpunktspannsystem, aber auch als Spannstock.
- Die Spannkraft wirkt direkt beim Werkstück, trotzdem ist das Werkstück ob klein, lang oder gross mit kurzen Werkzeugen sehr gut zugänglich. (Die Einschränkung ist der Maschinentisch)!
- Bei der Dreiseitenbearbeitung ist auch Mehrfachspannung möglich.
- Es können über 200 verschiedene Spannmodule, sowie Rohmodule, Zentrischspanner, Dreibackenfutter, Spannzangenfutter, Vakuumspannmodule usw. aufgesetzt werden. Die Schnittstelle ist immer dieselbe.
- Sehr schnelles Umrüsten!
- Wenig Reinigungsaufwand, da keine T-Nuten vorhanden sind.
- Besonders gut geeignet für 5-Achsen-Maschinen. Alle Spannvorrichtungen können auch auf Horizontal- und Vertikalmaschinen universell eingesetzt werden.

Benefits of Triag 5-axis workholding systems:

- The lower base rails serve both as a mechanical zero-point clamping system, but also as a vice.
- The tension acts directly at the workpiece, the workpiece is still, whether small, long or large, very accessible with short tools. The constraint is the machine table!
- 3-side machining is possible as well.
- There may be placed over 200 different clamping modules, as well as raw modules, self-centring modules, three jaw chuck, collet chuck, vacuum clamping modules and so on. The interface is always the same.
- Very fast setup!
- Reduced cleaning required, since no T-slots available.
- Especially suitable for 5-axis machines. All clamping devices can also be used universally on horizontal and vertical machines.



Geeignet sowohl für kleine ...
Especially suited for small ...

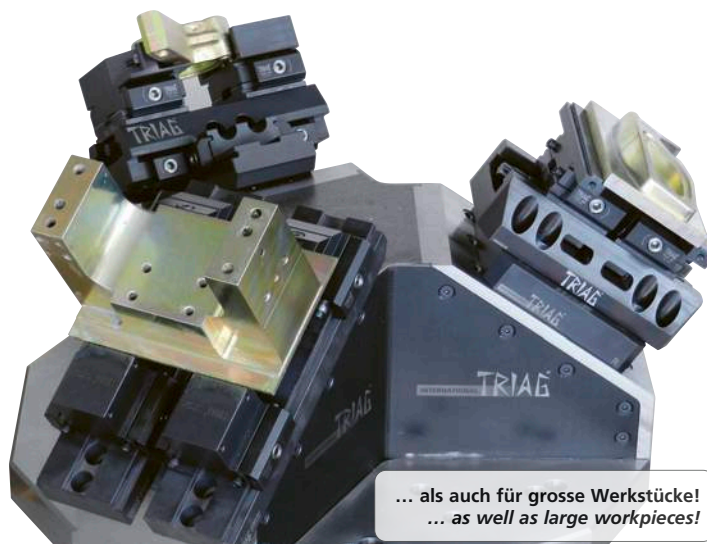

... als auch für grosse Werkstücke!
... as well as large workpieces!

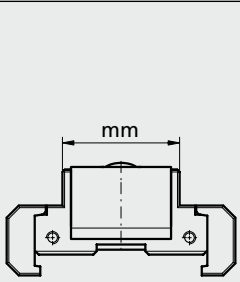
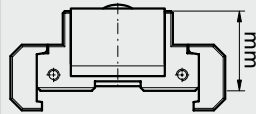
| System System | | bei Anschlagmodulen for end module | | Modulnutzbreite Module clamping width | | Modulnutzhöhe Module clamping height | |
|------------------|---|---|--------------------------------------|--|--|---|---|
| A | Apto Clamp | N | nitriergehärtet nitrated | 19 |  | 34 |  |
| P | Power Clamp | D | durchgehärtet through hardened | 25 | | | |
| C | Compact Clamp | bei Spanmodulen for vice modules | | 26 | | | |
| M | Micro Clamp | 1 | Anzahl Spannbacken Number of jaws | 34 | | | |
| V | Vorrichtungsbau module Workholding modules for dedicated fixtures | 2 | | 43 | | | |
| | | 3 | | 48 | | | |
| | | - | keine Spannbacke no clamping jaw | 58 | | | |
| | | | | 61 | | | |
| | | | | 68 | | | |
| | | | | 78 | | | |
| | | | | 94 | | | |
| | | | | 125 | | | |

P S 1 R 48 N 34 -80

| Modultyp Type of module | |
|----------------------------|----------------------------------|
| A | Anschlagmodul End module |
| S | Spannmodul Clamping module |
| T | Trägermodul Supporting module |
| R | Rohling Blank |

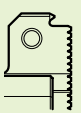
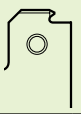
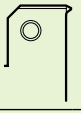
| Anschlagfläche der Module Datum face | |
|---|--|
| F | Anschlagfläche glatt Datum face flat |
| R | Anschlagfläche geriffelt Datum face double serrated |
| D | eine Seite glatt, eine Seite geriffelt one face flat, one face double serrated |
| G | Anschlagfläche gerillt Datum face serrated |
| X | spezielle Ausführung special execution |
| 5X | 5axes Clamp |
| P |  Fläche unterhalb der Prägung gerillt Area below the stamping serrated |
| PF |  Fläche unterhalb der Prägung glatt Smooth surface below the stamping |
| PV |  Präge vorstehend, Fläche unterhalb der Prägung glatt Stamping protruding, surface below the stamping flat |
| P6 | prägen / stamping |

| Backenhub Stroke of clamping jaw | |
|-------------------------------------|--|
| N | Niederzug Pull down |
| L | linear / parallel linear / parallel |
| - | ohne Spannbacke no clamping jaw |

| Spannbackentyp Type of clamping jaw | |
|--|---|
| B01 | Spannbacken Clamping jaws |
| - B313 | |
| -013 | Modul ohne Spannbacken Module without clamping jaw |
| -105 | |

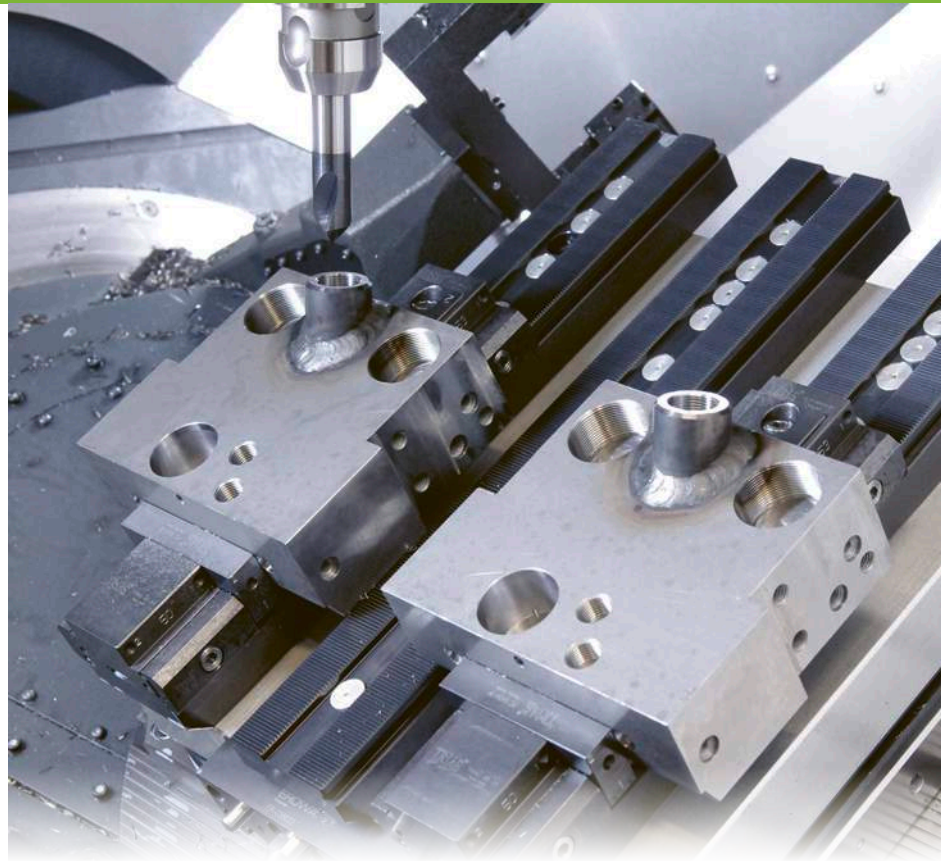

Die Basisschiene ist die Grundlage des Power Clamp Spannsystems

Der Einsatz der Basisschiene als Modularspannstock ist jedem Mechaniker ein Begriff. Die Vorteile ihres Einsatzes als mechanisches Nullpunktsystem sind in der Zwischenzeit ebenfalls ins Planungsdenken der mechanischen Fertigung eingeflossen.

Die Power Clamp-Schiene dient als Basis für über 200 verschiedene Spannmodule, Zentrischspanner, Rohlingsmodule und Vakuumplatten.

The serrated base rail is the basic structure of the Power Clamp workholding system

Using the base rail as a modular workholding vise is standard practice to any mechanic. The advantages of using it as a zero point system have also widely influenced the planning stages of mechanical production.

The Power Clamp base rail serves as a supporting plate for more than 200 different clamping modules, self centring vises, blank modules and vacuum clamping plates.

Toleranz gilt für alle PCB-Basisschienen / Tolerance applies to all PCB base rails

Toleranzklassen
Tolerance classes

| | |
|----|--------|
| P6 | +0.06 |
| P5 | +0.05 |
| P4 | +0.04 |
| P3 | +0.03 |
| P2 | +0.02 |
| P1 | +0.01 |
| P0 | +0.005 |
| M0 | -0.005 |
| M1 | -0.01 |
| M2 | -0.02 |
| M3 | -0.03 |
| M4 | -0.04 |
| M5 | -0.05 |
| M6 | -0.06 |

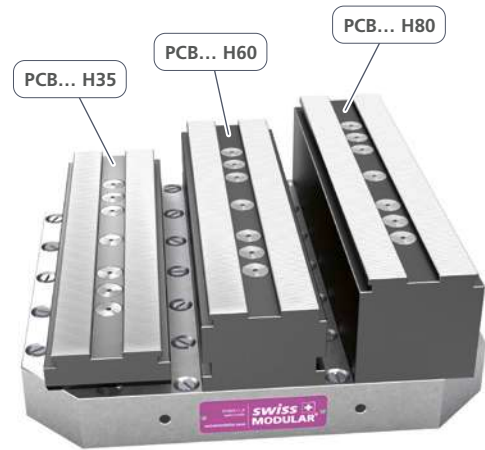
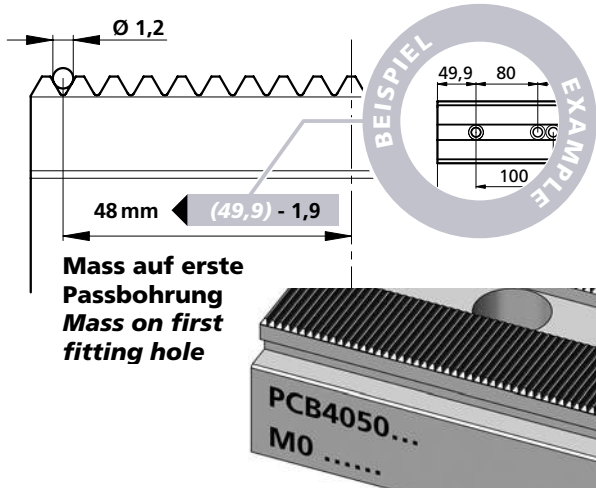

PCB6090 kg ~1,7

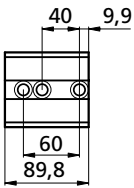

PCB25300 kg ~5,4

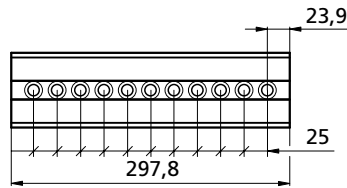

PCB4050500 kg ~9,5

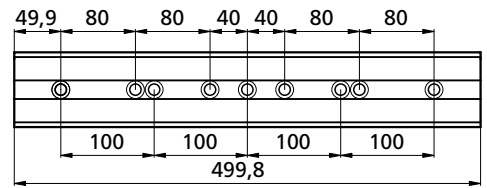

PCB4050125 kg ~2,3

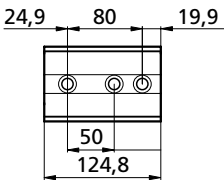

PCB25200 kg ~3,6

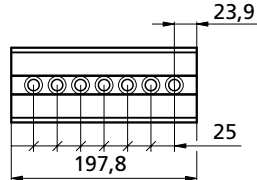

PCB4050550 kg ~10,3

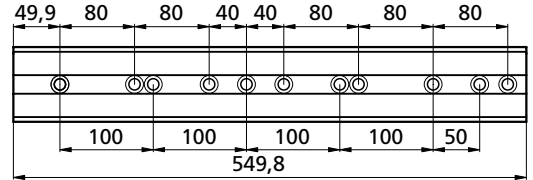

PCB4050220W2 kg ~4,1

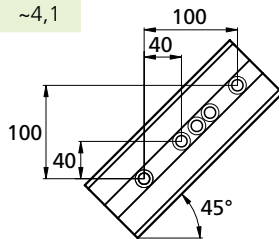
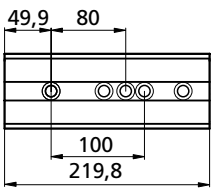

PCB4050600 kg ~11,3

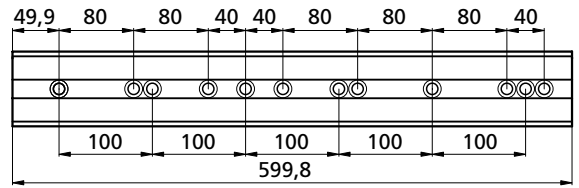

PCB2550250 kg ~4,5

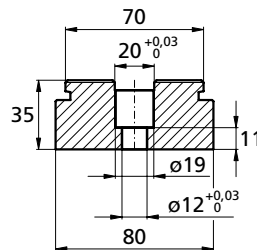
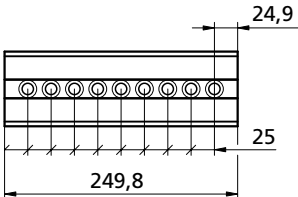

PCB4050650 kg ~12,2

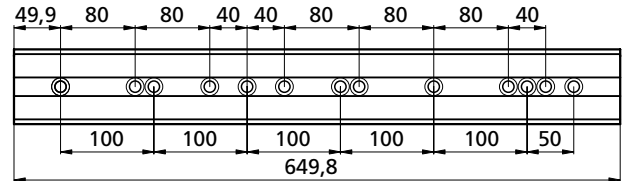

PCB50320 kg ~6,0

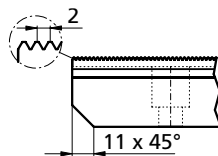
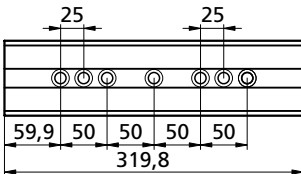

PCB4050700 kg ~13,2

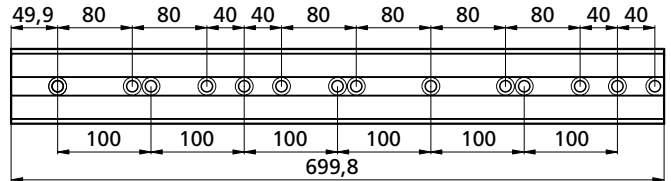

PCB4050350 kg ~6,5

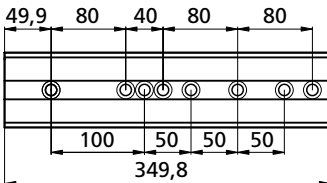

PCB4050750 kg ~14,1

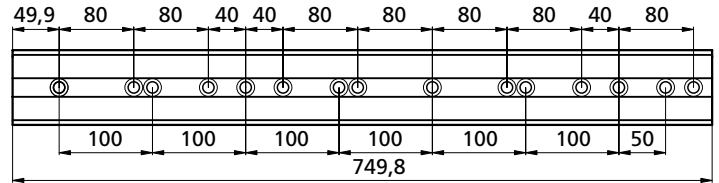

PCB4050400 kg ~7,5

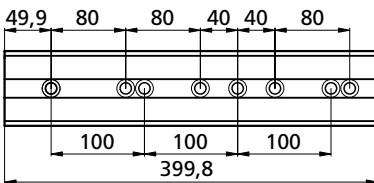

PCB4050800 kg ~15,0

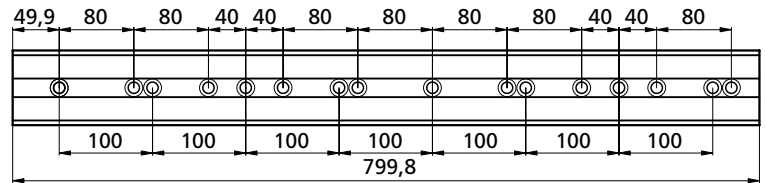

PCB4050450 kg ~8,4

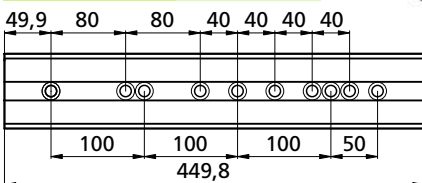

PCB4050400

Basisschienen in Zoll
Base rails in inch



Bestellbeispiel / Ordering example: **PCB4050125**

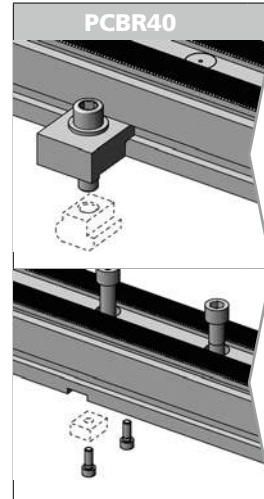
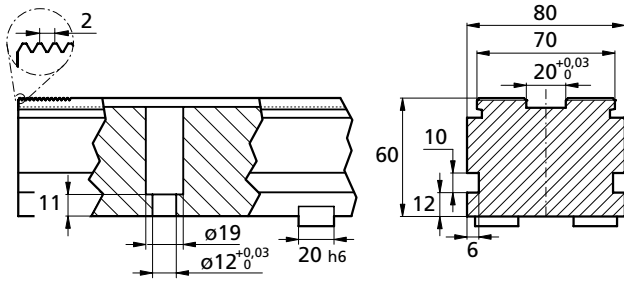

1. Befestigung 1. Fastening
Mit den seitlichen Pratten, kann die Basisschiene frei auf Ihrem Maschinentisch montiert werden.
With the lateral clamps, the base-rail can be mounted freely on your machine table.

2. Befestigung 2. Fastening
Diese Nutensteine sind zum Ausrichten der Basisschiene auf Ihrem Maschinentisch.
These t-slot nuts are for aligning the base-rail on your machine table.

| | |
|--------------------|-----------------|
| PCB50320H60 | |
| 1 | 1x TF190449 |
| 2 | 2x M6X12ISO4762 |
| 3 | 2x SM1136-20 |
| kg | ~10,3 |

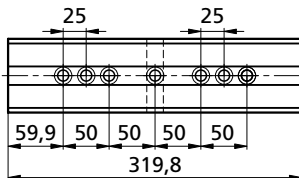

| | |
|---------------------|-----------------|
| PCB100350H60 | |
| 1 | 1x TH170888 |
| 2 | 2x M6X12ISO4762 |
| 3 | 2x SM1136-20 |
| kg | ~11,7 |

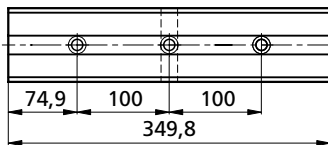

| | |
|---------------------|-----------------|
| PCB100400H60 | |
| 1 | 1x TB140546 |
| 2 | 2x M6X12ISO4762 |
| 3 | 2x SM1136-20 |
| kg | ~13,4 |

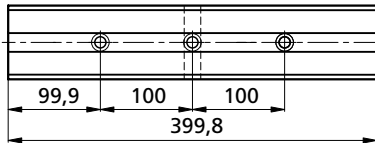

| | |
|---------------------|-----------------|
| PCB100500H60 | |
| 1 | 1x TB140553 |
| 2 | 2x M6X12ISO4762 |
| 3 | 2x SM1136-20 |
| kg | ~16,7 |

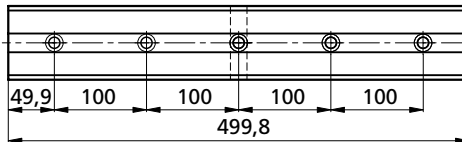

| | |
|---------------------|-----------------|
| PCB100600H60 | |
| 1 | 1x TB140556 |
| 2 | 2x M6X12ISO4762 |
| 3 | 2x SM1136-20 |
| kg | ~20,1 |

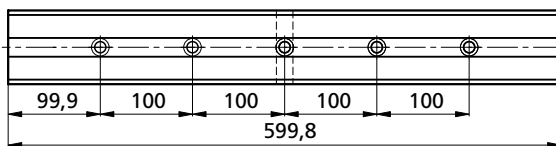

| | |
|---------------------|-----------------|
| PCB100650H60 | |
| 1 | 1x TB140559 |
| 2 | 2x M6X12ISO4762 |
| 3 | 2x SM1136-20 |
| kg | ~21,8 |

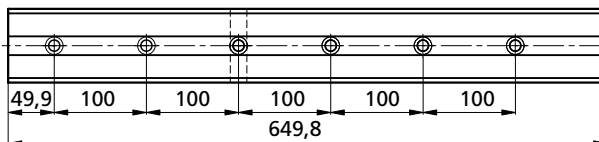

| | |
|---------------------|-----------------|
| PCB100690H60 | |
| 1 | 1x ZL100122 |
| 2 | 2x M6X12ISO4762 |
| 3 | 2x SM1136-20 |
| kg | ~22,6 |

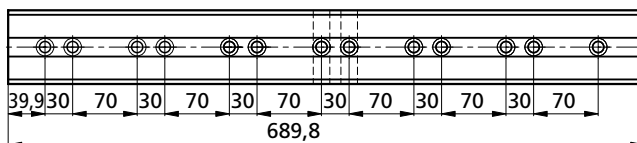

| | |
|---------------------|-----------------|
| PCB100850H60 | |
| 1 | 1x TB140562 |
| 2 | 2x M6X12ISO4762 |
| 3 | 2x SM1136-20 |
| kg | ~27,9 |

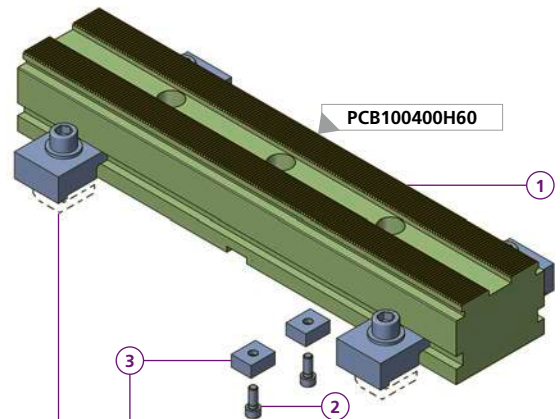
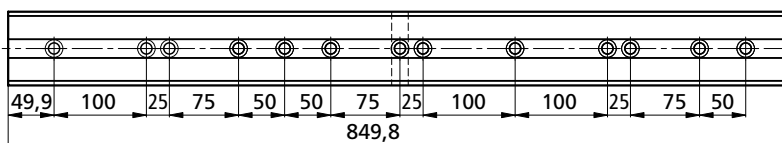

Zubehör / Accessories p. 338

| | |
|---------------|------------------|
| PCBR40 | |
| 4 | 1x M12X45ISO4762 |
| 5 | 1x TN100251 |
| 6 | 1x TK200035 |
| kg | ~0,25 |

T-Nutensteine T-slot nuts
T-Nutensteine je nach Maschinentisch, muss separat bestellt werden.
T-slot nuts depending on the machine table, must be ordered separately.

Bestellbeispiel / Ordering example: 1x PCB100400H60 & 2x M6X12ISO4762 & 2x SM1136-20

PCB4050125H80 kg ~5,5

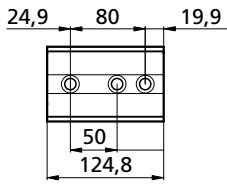

PCB50320H80 kg ~14,3

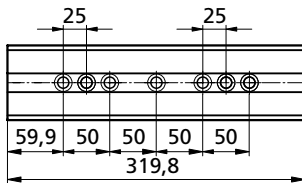

PCB50350H80 kg ~15,8

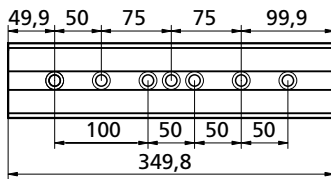

PCB50400H80 kg ~18,1

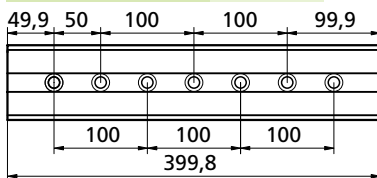

PCB50450H80 kg ~20,2

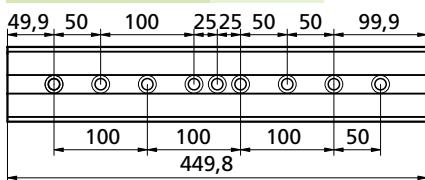

PCB50500H80 kg ~22,6

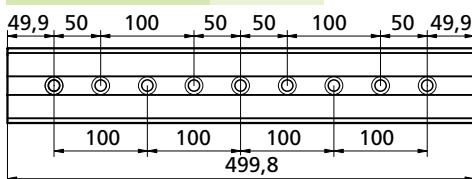

PCB50550H80 kg ~24,7

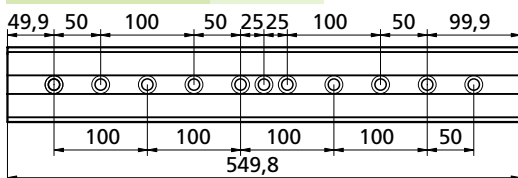

PCB50600H80 kg ~27,3

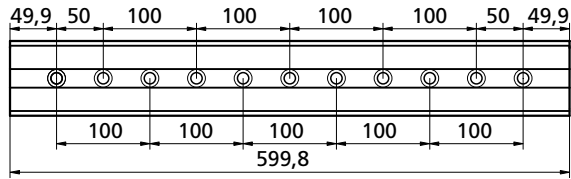

PCB50650H80 kg ~29,2

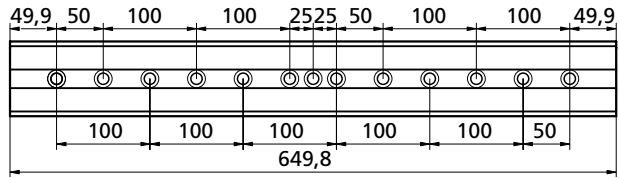

PCB50700H80 kg ~31,5

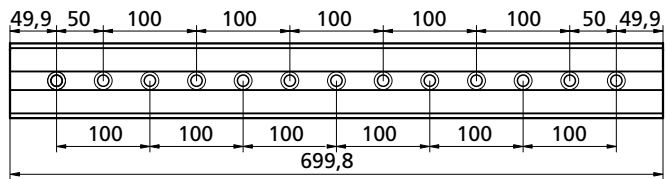

PCB50750H80 kg ~33,9

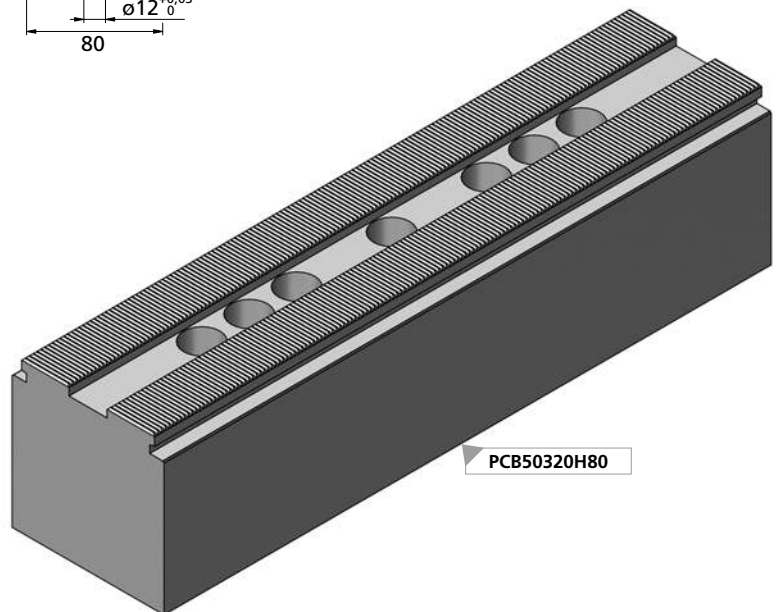
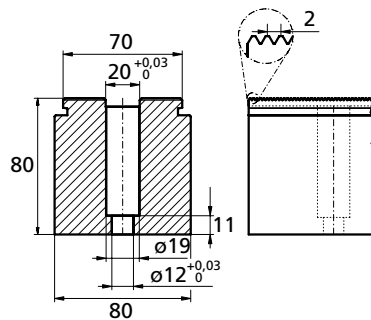
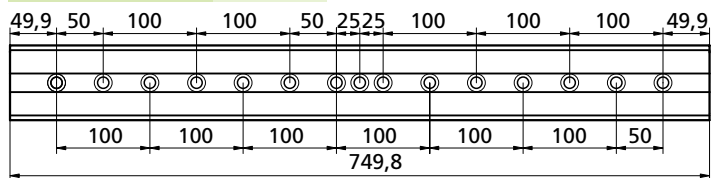

PCB50320H80

PCMB50600H175 kg ~39

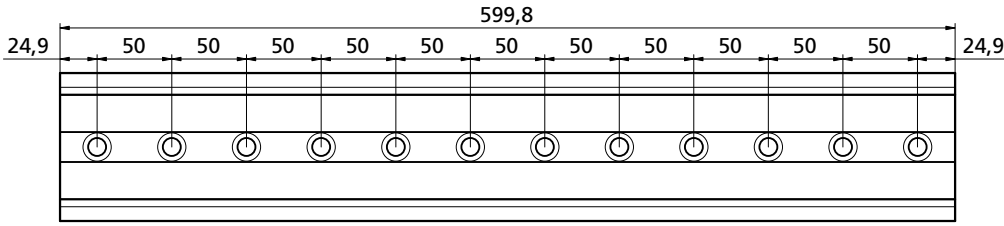

PCMB50500H175 kg ~34

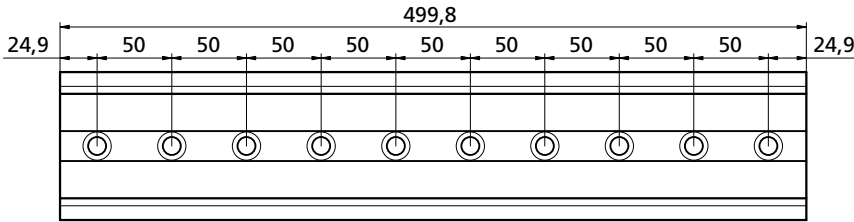

PCMB50400H175 kg ~27

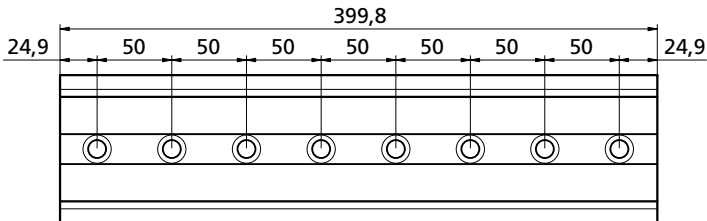

PCMB50300H175 kg ~22

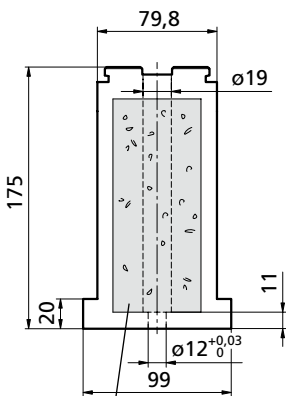
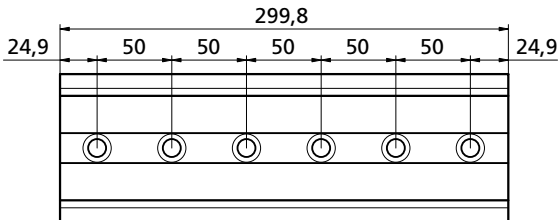

Epoxy Mineral
 Für gute Vibrationsdämpfung
 For brilliant dampening effect

Kupplungsstück (Basisschienen zum koppeln) Coupling element (Base rails for coupling)

powerCLAMP

Kupplungsstücke für PCB Basisschiene auf Mineralgus-Türmen

Mit diesen Kupplungsstücken ist es möglich, die PCB Basisschienen zu verlängern. Aufgrund des durchgängigen Kraftschlusses wird eine übermäßige Belastung des Mineralgussturmes vermieden. Erforderlich ist eine Modifikation der Enden der Basisschienen gemäss der untenstehenden Zeichnung durch den Anwender. Selbstverständlich können neue Schienen bereits mit dieser Modifikation ausgeliefert werden.

So können die zwei Kupplungsstücke montiert werden, die nach dem Platzieren der Schienen eingesetzt und festgezogen werden. Eine zusätzliche Schraube (B) nimmt allfällige, senkrecht zur Befestigungsfläche auftretende Kräfte auf.

Coupling element for PCB base rails mounted on epoxy mineral tombstones

With this coupling element, it is possible to extend the PCB base rail by a second rail. Due to the frictional connection, the behaviour of the associated items is approximate to the behaviour of a continuous rail. A modification according to the drawing below (made by the customer) is required at the end of the base rails. New base rails can be supplied with this modification.

So the two coupling elements can be placed between the base rails. An additional screw (B) is taken the force flatwise to the seating.

Detailzeichnung zum Bearbeiten aller Basisschienen H35, um die Aussparung für das Kupplungsstück bei vorhandenen Schienen nachträglich herzustellen.

Detail drawing for machining all base rails H35 to retrofit the recess for the coupling piece on existing rails.

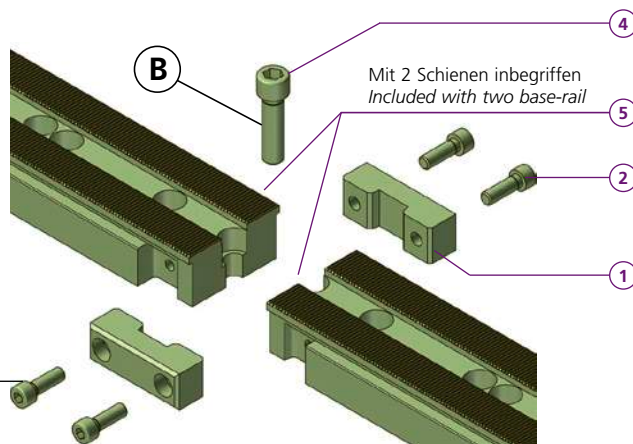
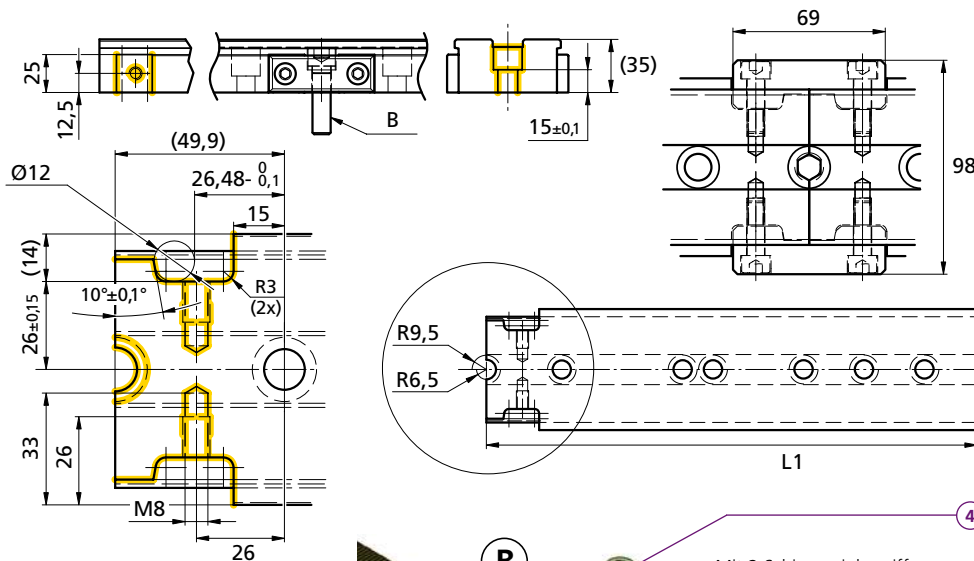

Montageanleitung siehe Video
Assembly instructions see video



| PCBP69SET | | PCB4050250KP | PCB4050400KP | PCB4050450KP | PCB4050500KP | PCB4050650KP | PCB4050700KP |
|-----------|------------------|--------------|--------------|--------------|--------------|--------------|--------------|
| 1 | 2x TW090078 | 5 | 5 | 5 | 5 | 5 | 5 |
| 2 | 4x M8X25ISO4762 | L1 = 250 | L1 = 400 | L1 = 450 | L1 = 500 | L1 = 650 | L1 = 700 |
| 4 | 1x M12X45ISO4762 | kg ~5,1 | kg ~7,9 | kg ~8,9 | kg ~9,9 | kg ~12,8 | kg ~13,8 |
| kg | ~0,4 | | | | | | |

Bestellbeispiel / Ordering example: PCB4050250KP

| PCB850SET | | PCB900SET | | PCB950SET | | PCB1000SET | |
|-----------|------------------|-----------|------------------|-----------|------------------|------------|------------------|
| 1 | 1x PCB4050400KP | 1 | 1x PCB4050650KP | 1 | 1x PCB4050700KP | 1 | 2x PCB4050500KP |
| 2 | 1x PCB4050450KP | 2 | 1x PCB4050250KP | 2 | 1x PCB4050250KP | 3 | 1x PCBP69SET |
| 3 | 1x PCBP69SET | 3 | 1x PCBP69SET | 3 | 1x PCBP69SET | 4 | 4x TWPAS1240 |
| 4 | 4x TWPAS1240 | 4 | 4x TWPAS1240 | 4 | 4x TWPAS1240 | 5 | 6x M12X40ISO4762 |
| 5 | 5x M12X40ISO4762 | 5 | 6x M12X40ISO4762 | 5 | 7x M12X40ISO4762 | 6 | 10x PCPF16L6 |
| 6 | 9x PCPF16L6 | 6 | 10x PCPF16L6 | 6 | 11x PCPF16L6 | 7 | 8x PCPF16L18 |
| 7 | 9x PCPF16L18 | 7 | 12x PCPF16L18 | 7 | 12x PCPF16L18 | kg | ~20,9 |
| kg | ~17,8 | kg | ~18,7 | kg | ~19,8 | | |

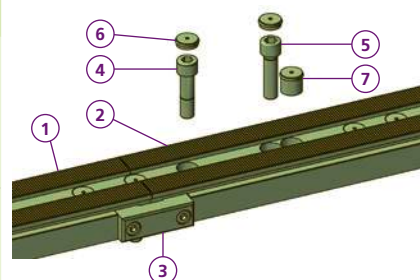

Bestellbeispiel / Ordering example: PCB850SET

Querschiene 90° Crossbar 90°

PCB250Q90-H35

powerCLAMP

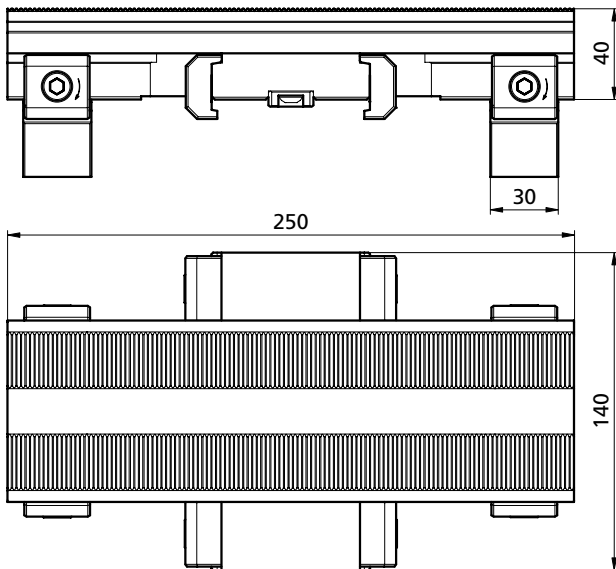
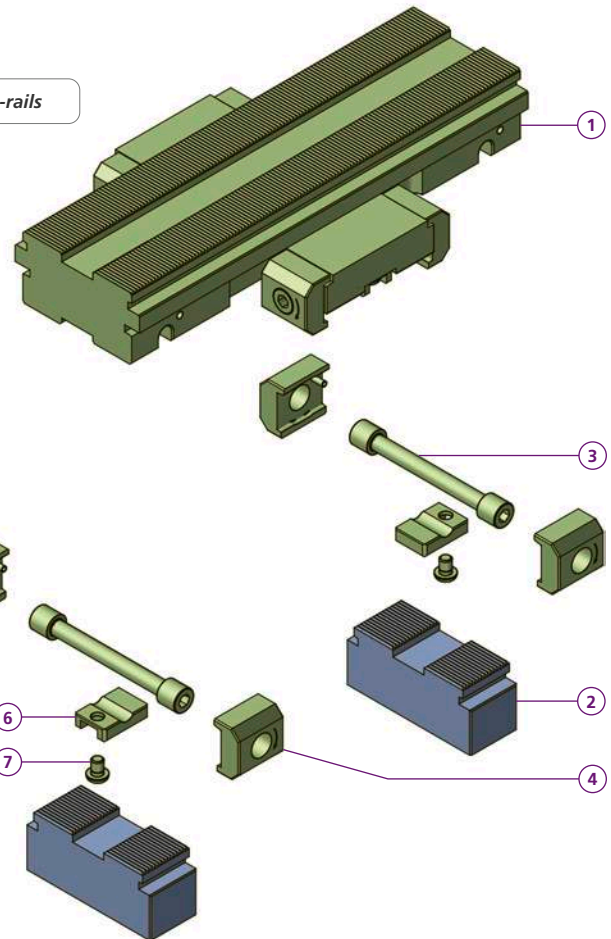
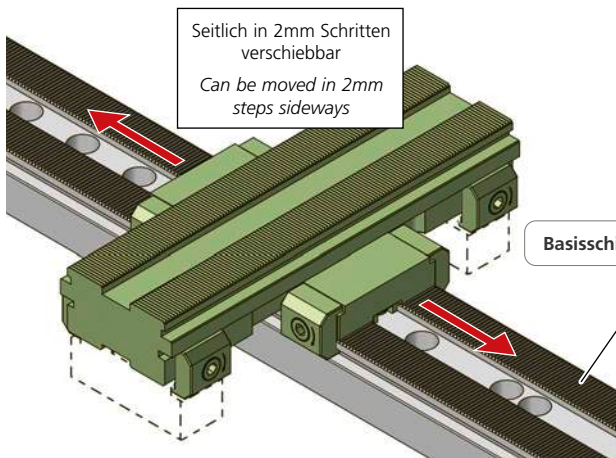

| PCB250Q90H35 | |
|--------------|----------------|
| ① | 1x TH151032 |
| ② | 2x |
| ③ | 4x PCS14 |
| ④ | 4x PCSP30L |
| ⑤ | 4x PCSP30R |
| ⑥ | 4x PCGU2030 |
| ⑦ | 1x M6X8ISO7380 |
| kg | ~8,18 |

Schienenhöhe / Rail height

| AS35 (H = 35) | AS60 (H = 60) | AS80 (H = 80) |
|------------------|------------------|------------------|
| | | |

Seitliche Stützen

Bei Gebrauch der Querschiene 90°, werden je nach Höhe der Basisschiene auf dessen sie aufgesetzt sind, zwei seitliche Stützen AS35 / AS60 / AS80 unterlegt.

Side support

When using the cross rail 90°, a side support AS35 / AS60 / AS80 is underlaid, depending on the height of the base rail on which it is placed.

Bestellbeispiel / Ordering example: PCB250Q90H35

Separat bestellen / Order separately

Erhöhung für 5-Achsenmaschinen Riser for 5-axis machines

PCUB60-130
PCUB100-200
PCUB100-300

powerCLAMP

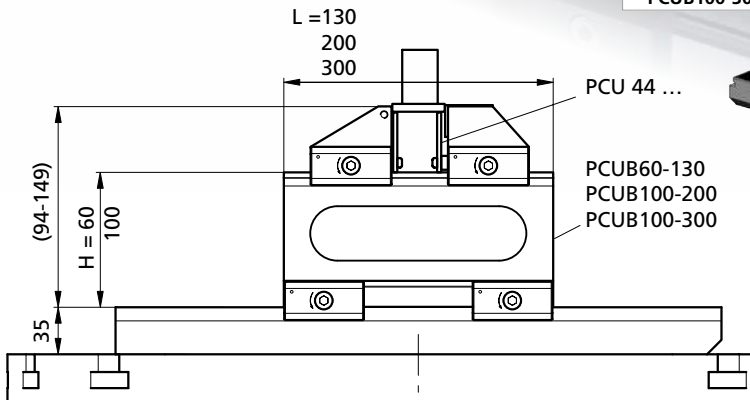
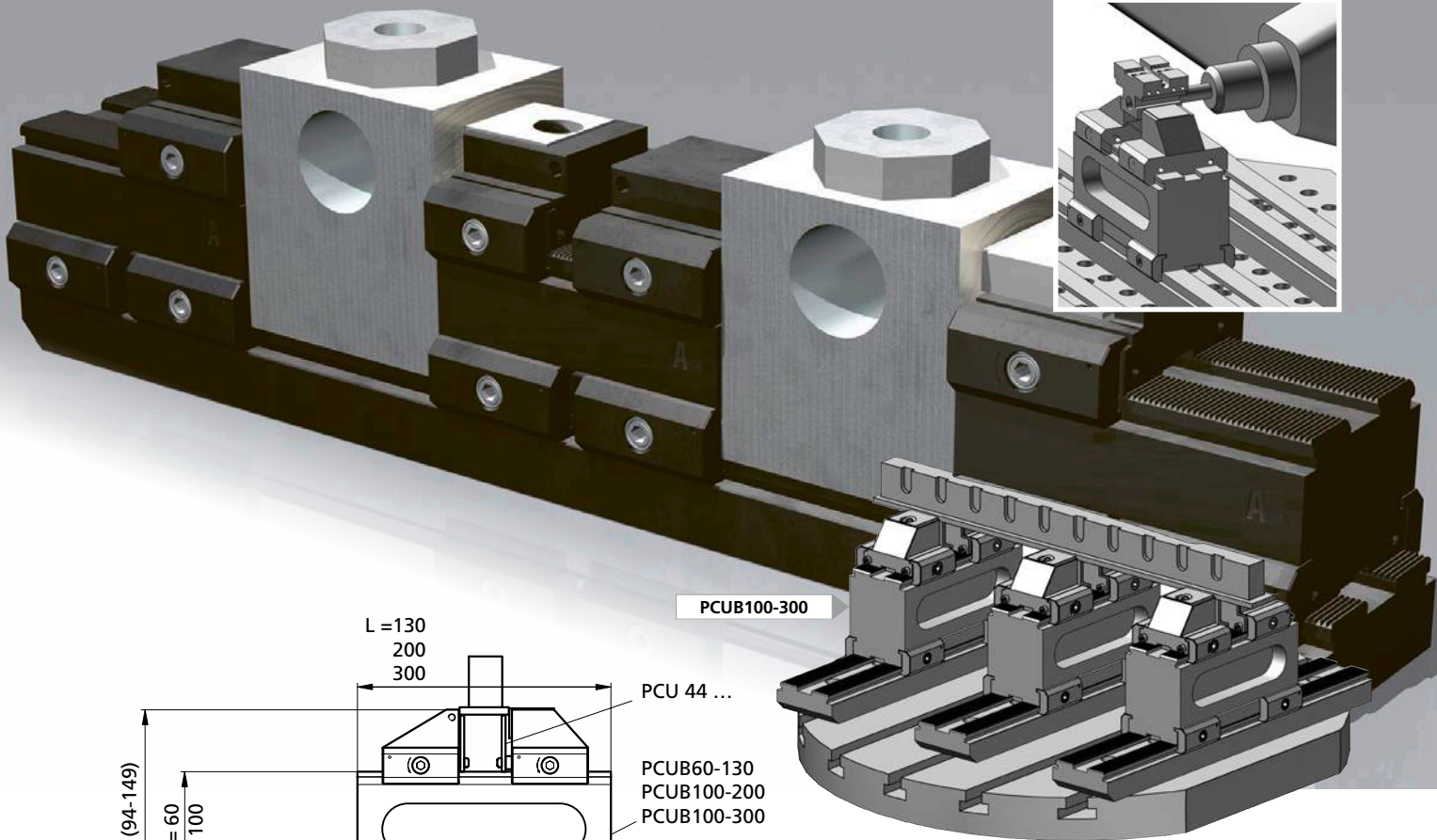

- | PCUB60-130 | |
|-------------|----------------|
| ① | 1x TK120596 |
| ③ | 2x PCSP60R |
| ④ | 2x PCSP60L |
| ⑤ | 2x PCS14 |
| ⑥ | 2x PCGU2049 |
| ⑦ | 2x M6X8ISO7380 |
| L | = 130 |
| H | = 60 |
| kg | ~5,8 |
| PCUB100-200 | |
| ① | 1x TK130108 |
| L | = 200 |
| H | = 100 |
| kg | ~10,5 |
| PCUB100-300 | |
| ① | 1x TK130109 |
| ③ | 3x PCSP60R |
| ④ | 3x PCSP60L |
| ⑤ | 3x PCS14 |
| ⑥ | 3x PCGU2049 |
| ⑦ | 3x M6X8ISO7380 |
| L | = 300 |
| H | = 100 |
| kg | ~16 |

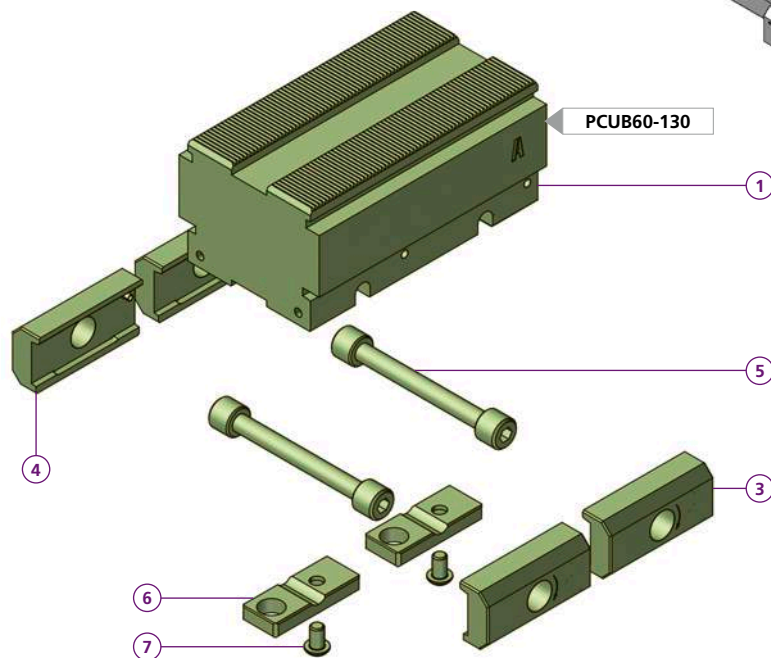

Bestellbeispiel / Ordering example: **PCUB100-200**

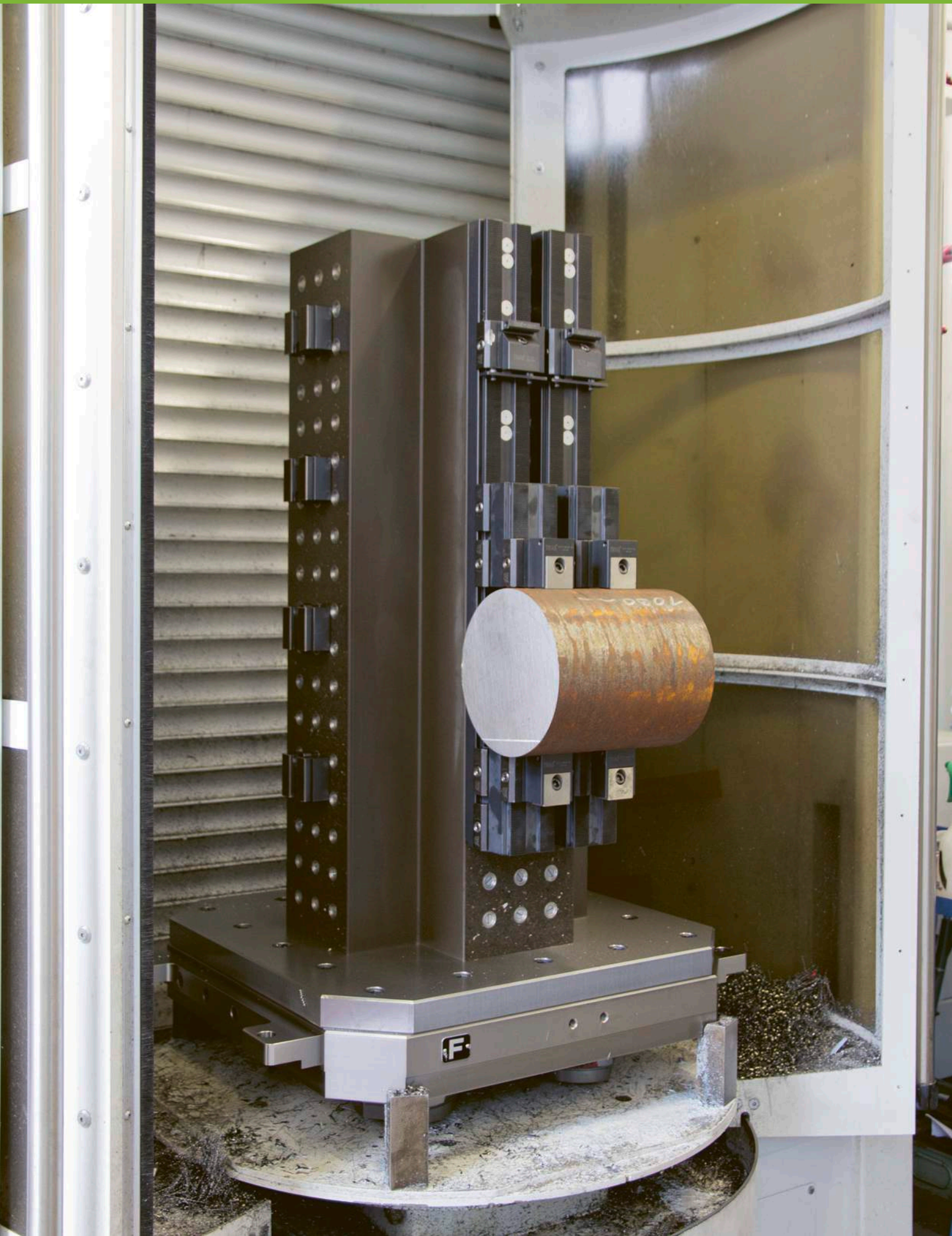

PCUB115-200-R25

PCUB115-300-R25

powerCLAMP

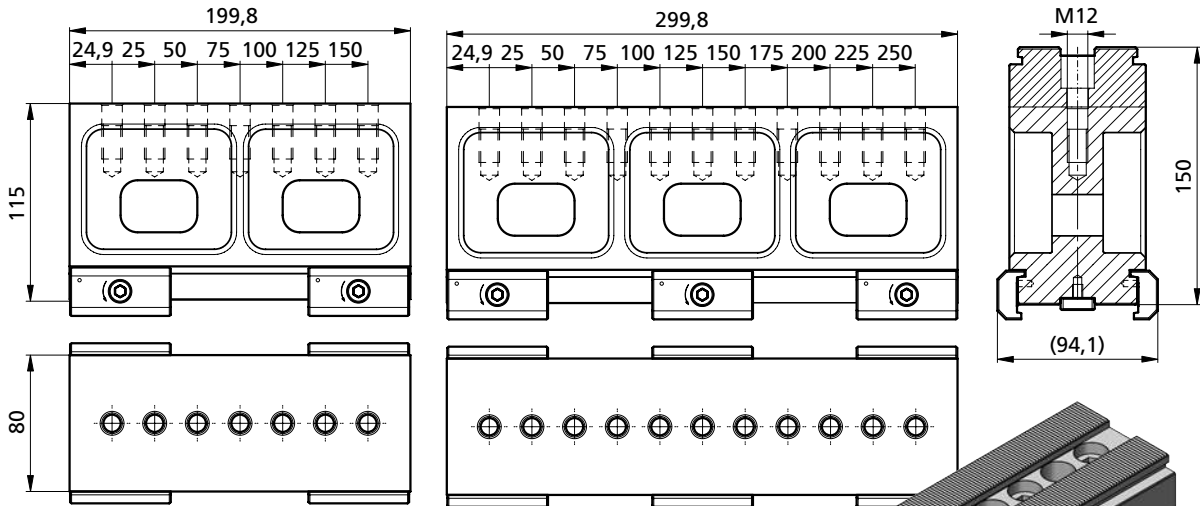

PCB25200 kg ~3,6

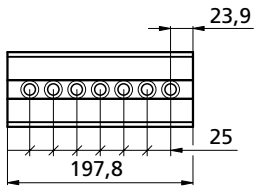

PCB25300 kg ~5,4

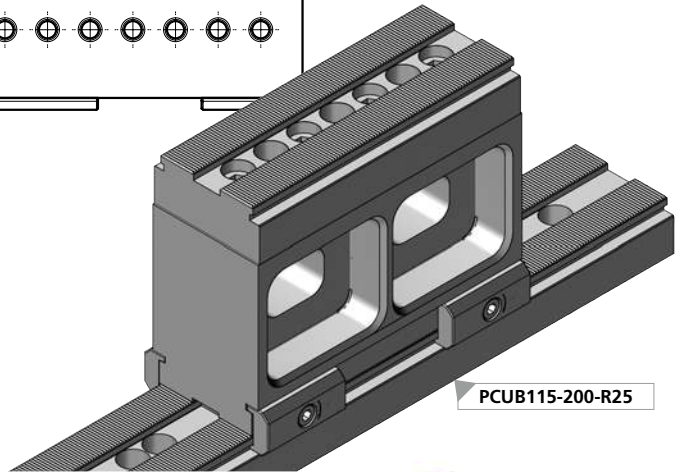
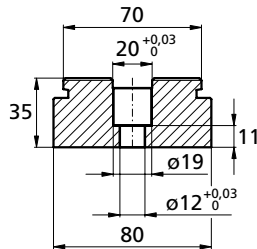
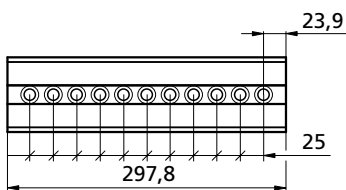

PCUB115-200-R25

PCUB115-200-R25

- 1 1x TK130323
- 2 1x PCB25200
- 3 2x PCSP60R
- 4 2x PCSP60L
- 5 2x PCS14
- 6 2x PCGU2049
- 7 2x M6X8ISO7380
- 9 2x TWPAS1240
- 10 2x M12X40ISO4762

kg ~13

PCUB115-300-R25

- 1 1x TK130324
- 2 1x PCB25300
- 3 3x PCSP60R
- 4 3x PCSP60L
- 5 3x PCS14
- 6 3x PCGU2049
- 7 3x M6X8ISO7380
- 9 2x TWPAS1240
- 10 4x M12X40ISO4762

kg ~19,6

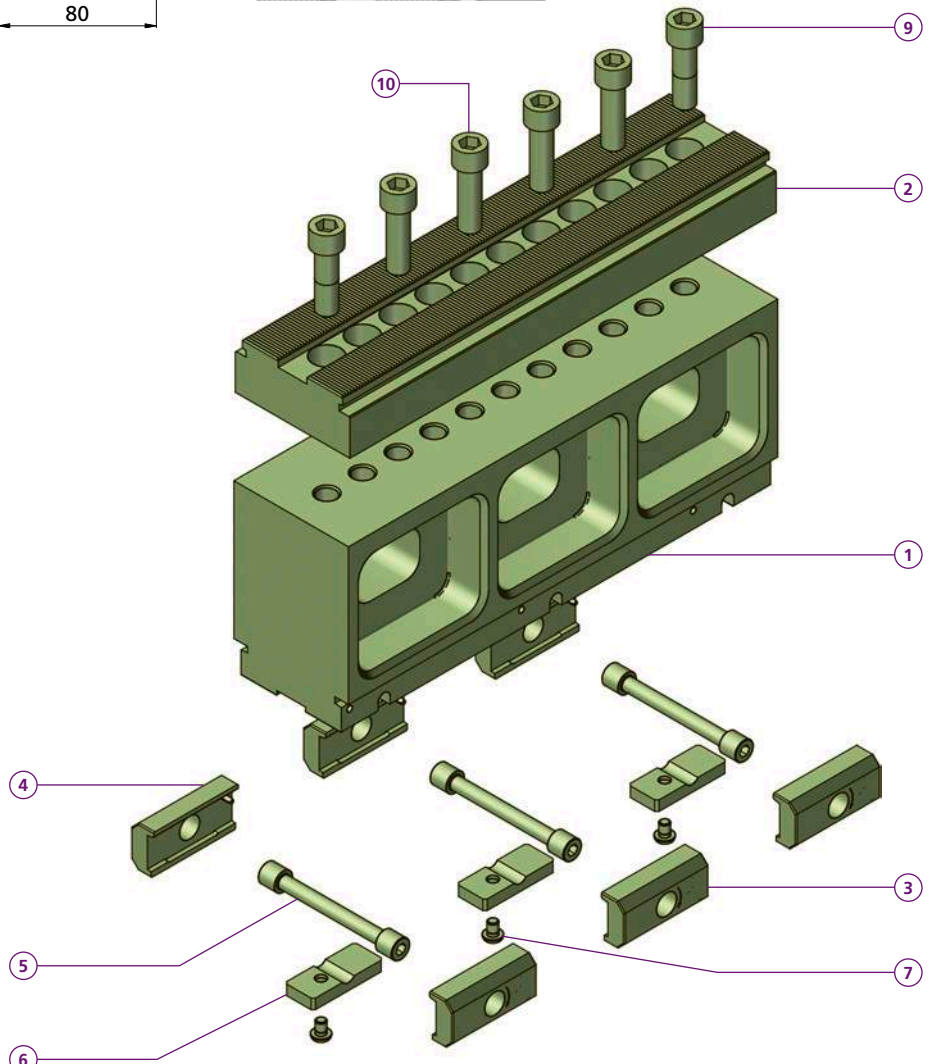

Bestellbeispiel / Ordering example: **PCUB115-300-R25**

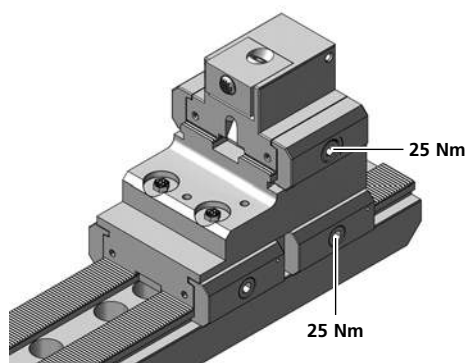
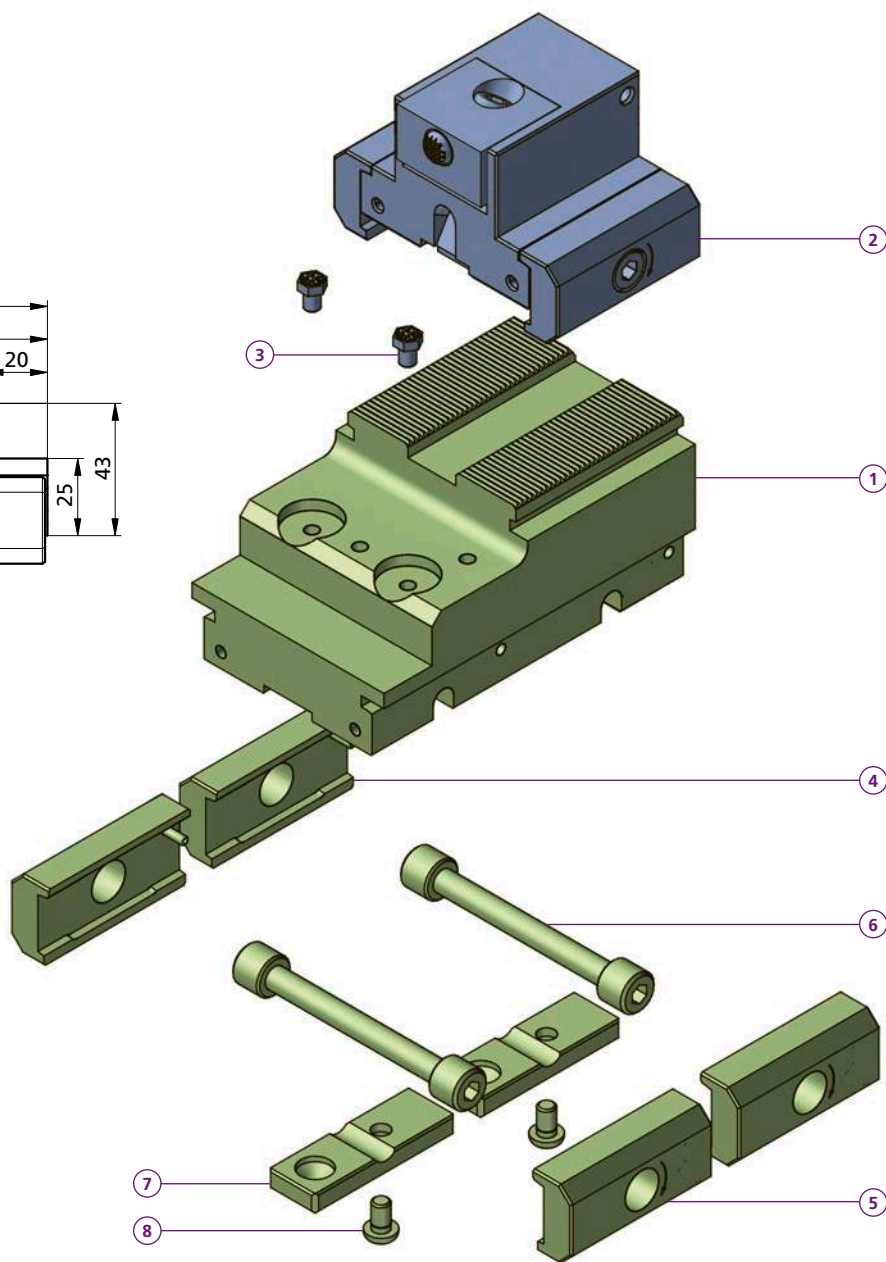
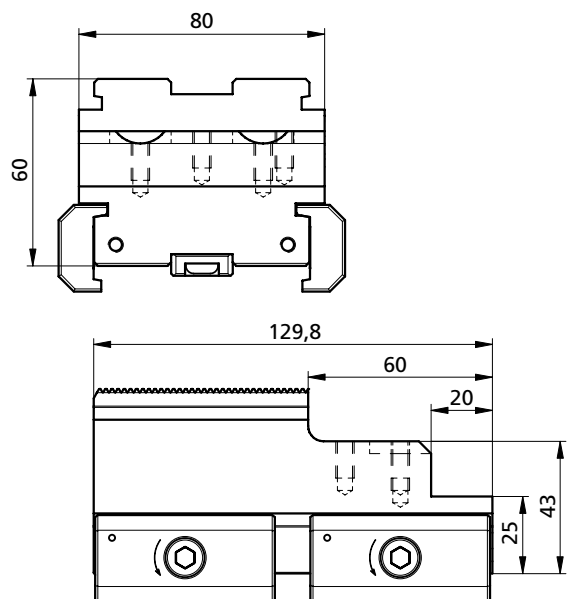

| PCUB60-70-130 | |
|---------------|-----------------|
| ① | 1x TK130707 |
| ② | 1x PS1F43N49-60 |
| ③ | 2x CCHMR |
| ④ | 2x PCSP60L |
| ⑤ | 2x PCSP60R |
| ⑥ | 2x PCS14 |
| ⑦ | 2x PCGU2049 |
| ⑧ | 2x M6X8ISO7380 |
| kg | ~4,3 |

p. 64

Zubehör / Accessories p. 337

Bestellbeispiel / Ordering example: PCUB60-70-130

Separat bestellen / Order separately

Schräge Basisschiene für 5-Achsenmaschinen Slanted base rail for 5-axis machines

**5axes
powerCLAMP**

| Art. Nr. | kg | Δ | H |
|--------------------|------|----------|-------|
| PCB50207W25 | ~9,2 | 25° | 131,5 |
| PCB50207W27 | ~9,5 | 27,5° | 139,7 |

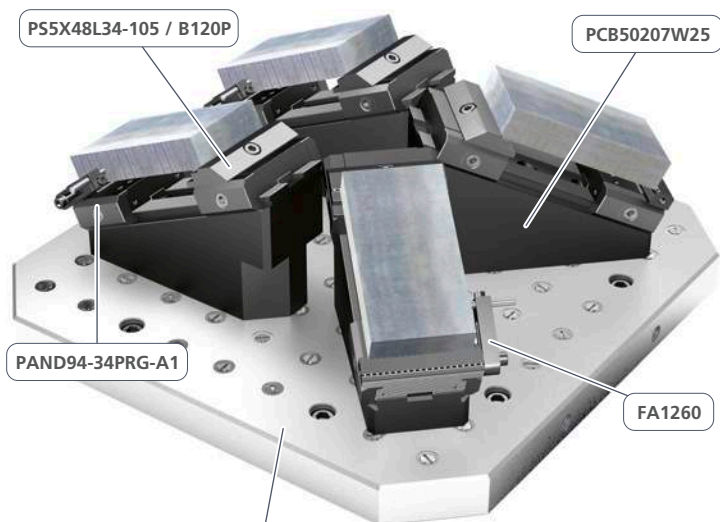

Optional erhältlich / Optional accessory
GPL500 x 40 / GPL400 x 40

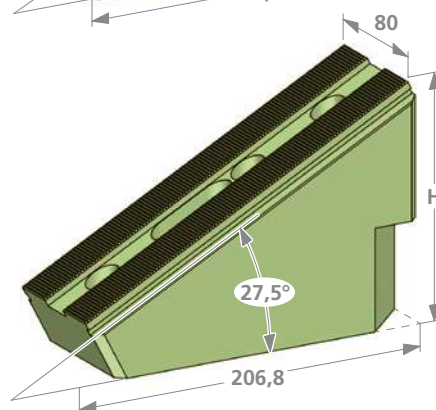
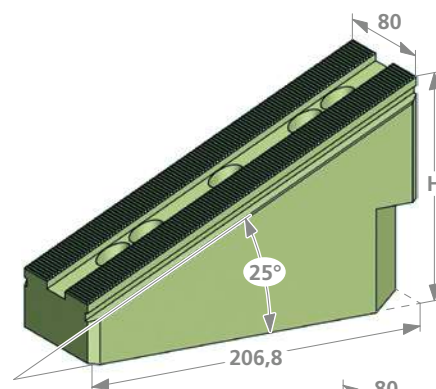

Die Basisschienen können auf einem 50 mm Raster je nach Bedarf parallel oder diagonal platziert werden.

The base rails can be placed on a 50 mm grid either parallel or diagonal as required.

| Art. Nr. | kg | Δ | \emptyset | H |
|---------------------|-----|----------|-------------|-------|
| PCT30P-153-4 | ~24 | 60° | 266 | 152,4 |

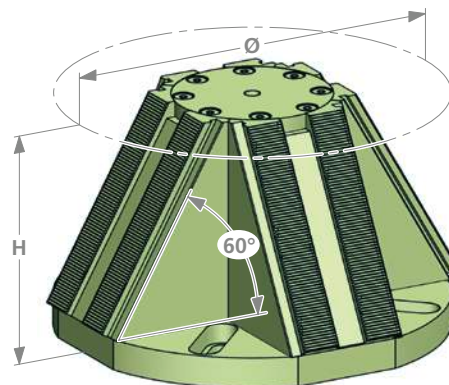
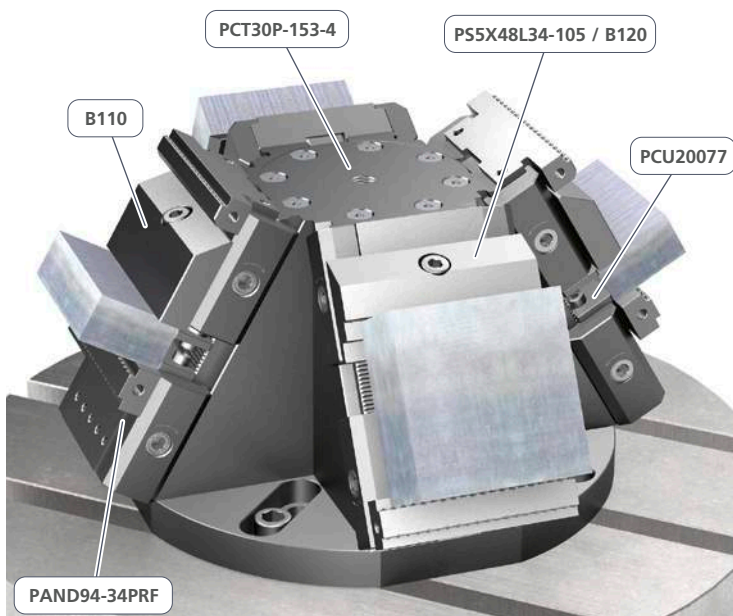

Die Stahl-Mineralgusspyramide verfügt über eine powerCLAMP Schnittstelle und ermöglicht eine kompakte und zugleich flexible 5-Achs-Bearbeitung. Die Module werden in einem Winkel von 60° montiert. Dank dem eingesetzten Mineralguss, hat die Konstruktion ein relativ tiefes Gewicht bei einer hohen Festigkeit.

The steel mineral casting pyramid has a powerCLAMP interface and enables compact and, at the same time, flexible 5-axis machining. The modules are mounted at an angle of 60°. Due to the mineral cast used, the construction has a relatively low weight with a high rigidity.

Monobloc Balken zu Teilapparat Monobloc powerCLAMP for 4th-axis

powerCLAMP

| Art. Nr. | kg | L | B |
|-------------------|-------|-----|---------|
| PCT110-300 | ~24,5 | 300 | 110x110 |
| PCT110-350 | ~27,5 | 350 | 110x110 |
| PCT110-400 | ~31,5 | 400 | 110x110 |
| PCT110-450 | ~35,5 | 450 | 110x110 |
| PCT110-500 | ~39,5 | 500 | 110x110 |
| PCT110-550 | ~43,0 | 550 | 110x110 |
| PCT110-600 | ~47,0 | 600 | 110x110 |
| PCT110-650 | ~51,0 | 650 | 110x110 |
| PCT110-700 | ~55,2 | 700 | 110x110 |

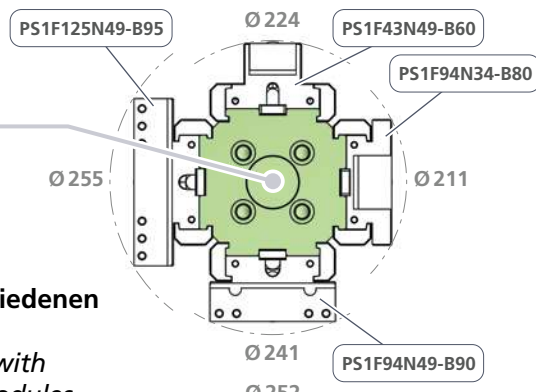
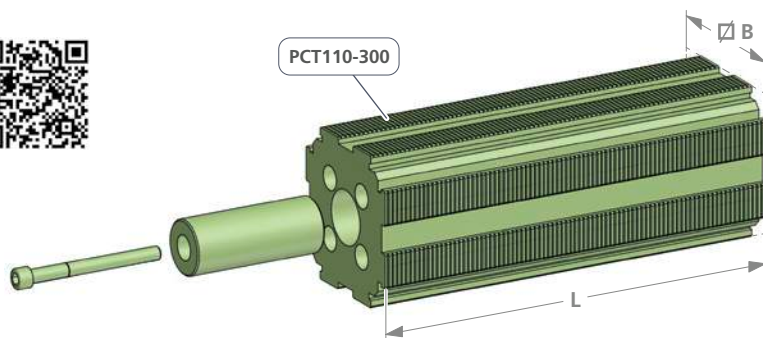

**Störkreise bei verschiedenen
Spannmodulen**
*Workpiece diameter with
different clamping modules*

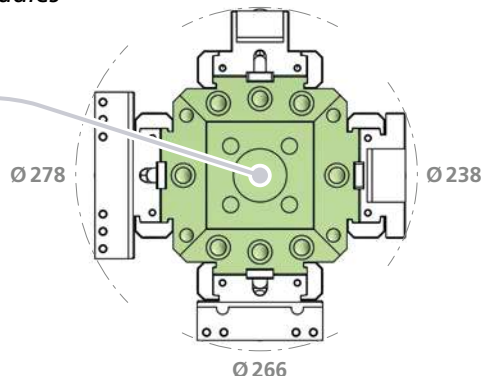

Stahl-Mineralguss
Steel-epoxy mineral

| Art. Nr. | kg | L | B |
|--------------------|--------|-----|---------|
| PCMT150-700 | ~83,0 | 700 | 150x150 |
| PCMT150-750 | ~89,0 | 750 | 150x150 |
| PCMT150-800 | ~95,0 | 800 | 150x150 |
| PCMT150-850 | ~101,0 | 850 | 150x150 |

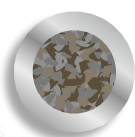

Reduziert Vibrationen und ist leicht
Reduces vibrations and is light

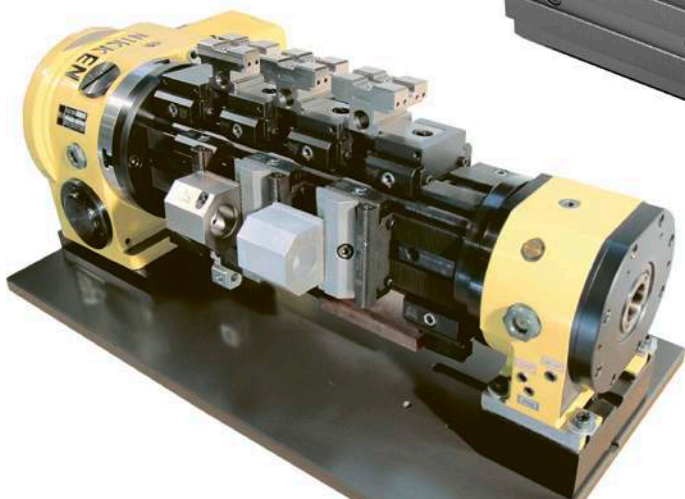

| Art. Nr. | kg | H | B |
|-----------------------|-------|-----|---------|
| PCT110-250MATS | ~20,0 | 250 | 110x110 |
| PCT110-300MATS | ~24,0 | 300 | 110x110 |

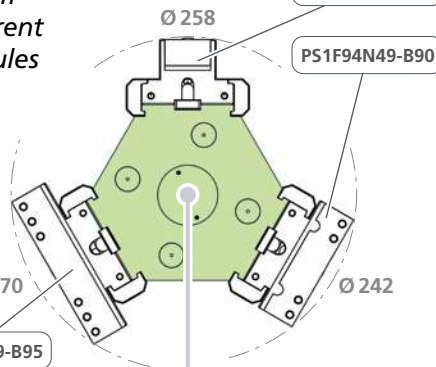
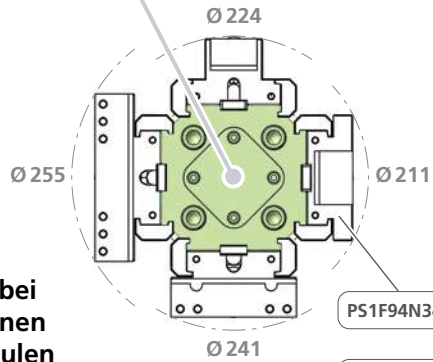
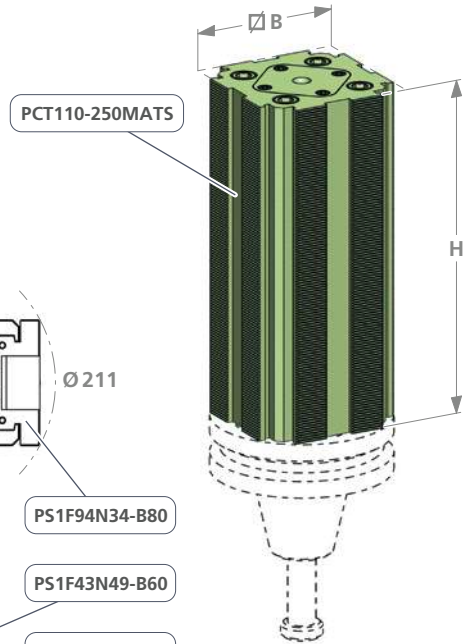

Störkreise bei verschiedenen Spannmodulen
Workpiece diameter with different clamping modules



| Art. Nr. | kg | H |
|-------------------------|-------|-----|
| PCT155-290-3MATS | ~28,8 | 290 |

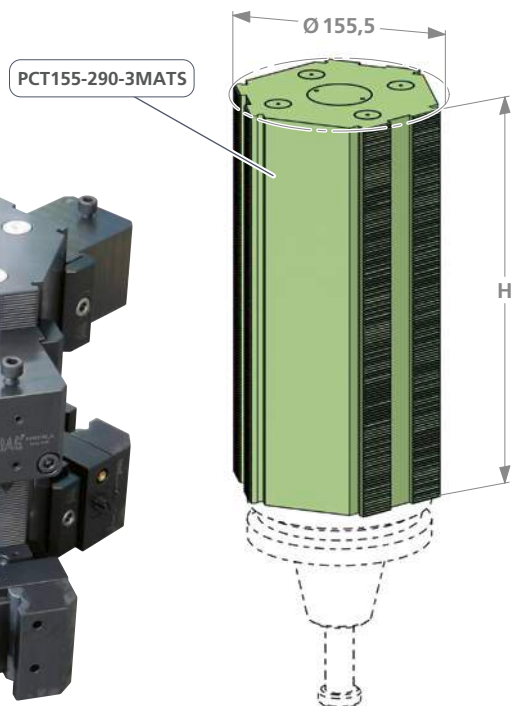

Spanntürme zu 5-Achs Bearbeitungszentren
Clamping fixtures for 5 axis machines

powerCLAMP



powerCLAMP p. 81



microCLAMP p. 178



triCENTRO p. 126

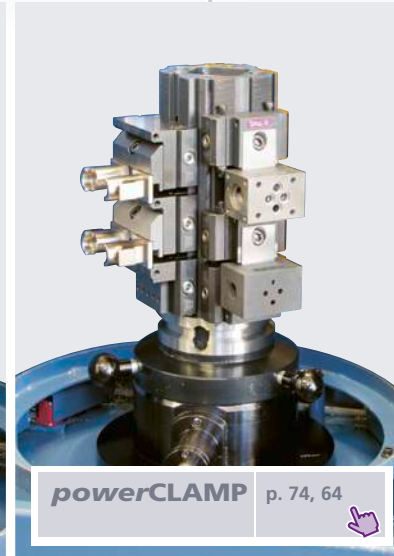

powerCLAMP p. 74, 64

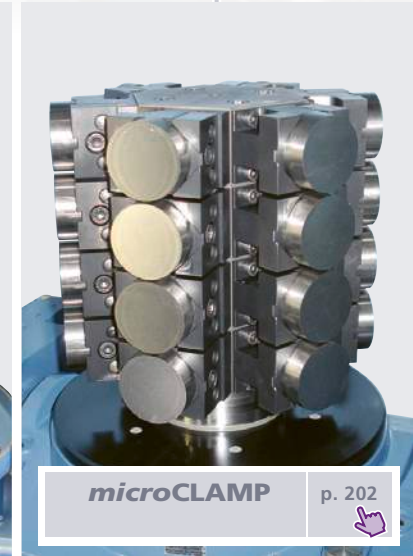

microCLAMP p. 202



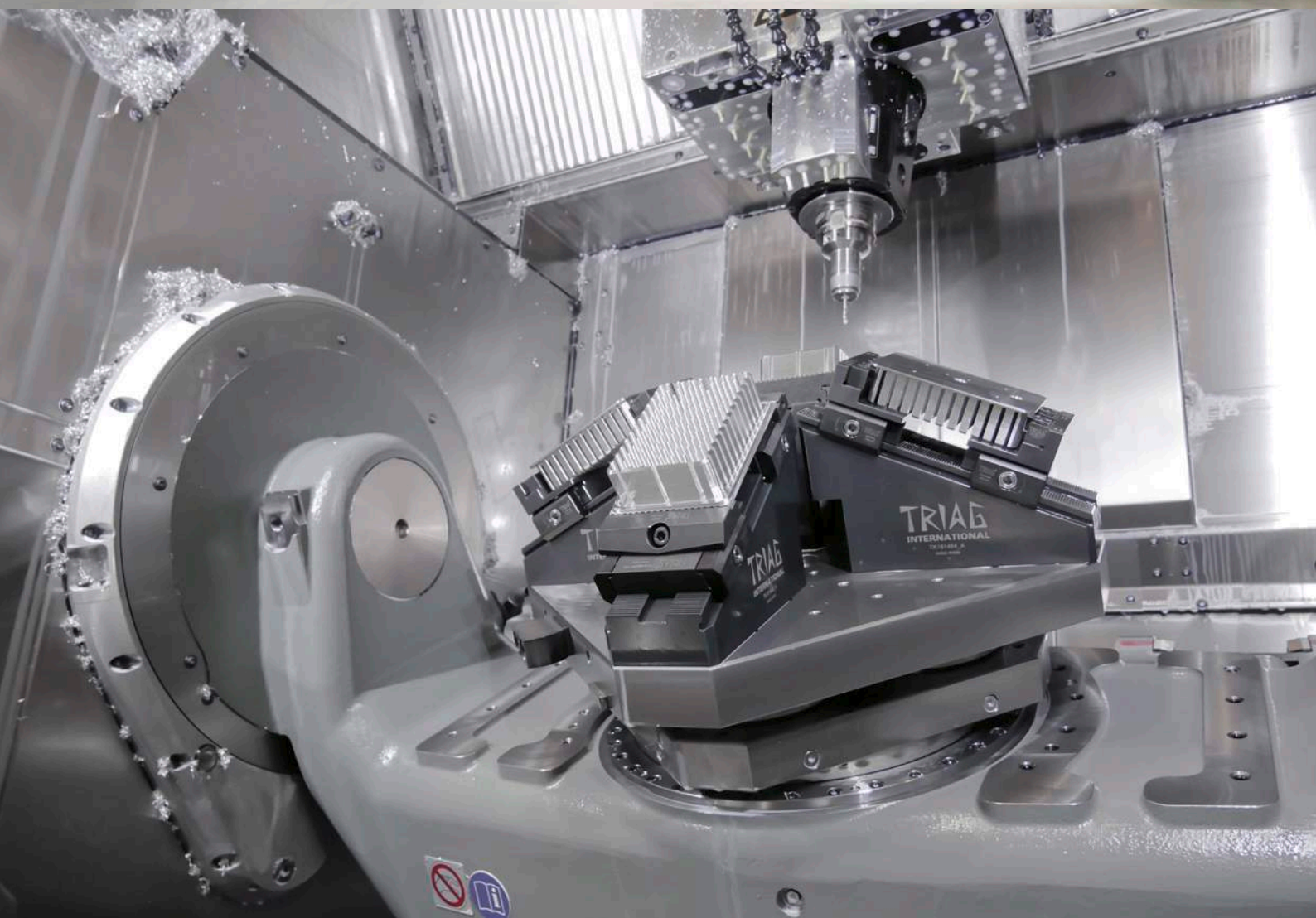

BESTELLBEISPIEL / ORDERING EXAMPLE

1x PCSET18-450A 2x PCSET18-N3 1x PS1X50N62-ER32

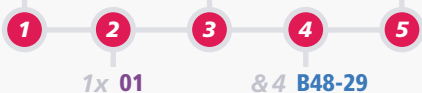

1x 01

& 4 B48-29

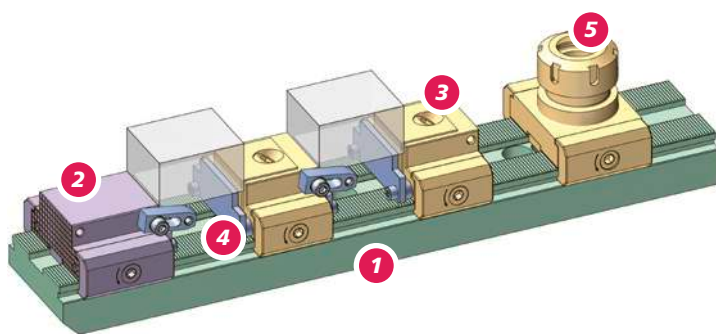

Zu jeder Basisschiene gehört 1 Anschlagmodul «Tabelle 2» nach Ihrer Wahl!
Each base rail comes with 1 end module "table 2" of your choice!

1 Basisschienen / Base-rails

| | | | |
|---------------------|------------|---------------------|------------|
| PCSET18-250A | PCB2550250 | PCSET18-600A | PCB4050600 |
| PCSET18-350A | PCB4050350 | PCSET18-650A | PCB4050650 |
| PCSET18-400A | PCB4050400 | PCSET18-700A | PCB4050700 |
| PCSET18-450A | PCB4050450 | PCSET18-750A | PCB4050750 |
| PCSET18-500A | PCB4050500 | PCSET18-800A | PCB4050800 |
| PCSET18-550A | PCB4050550 | | |

2 Anschlagmodule / End modules

| | | | | | |
|--------------------------|--------------------------|---|-------------------|--------------------------|--------------------------|
| 48 | | 78 | | 94 | |
| PAND 48-34 | PAND 48-49 | PAND 78-34 | PAND 78-49 | PAND 94-34 | PAND 94-49 |
| | | | | | |
| 01 | 02 | 05 | 06 | 07 | 08 |
| PAND 48-34 PRF-A1 | PAND 48-49 PRF-A1 | <ul style="list-style-type: none"> F = glatt / flat R = geriffelt / double serrated = Direktprägebacken / Direct stamping | | PAND 94-34 PRF-A1 | PAND 94-49 PRF-A1 |
| | | | | | |
| 03 | 04 | | | 09 | 10 |

5 Dreibackenfutter | Spannzangenmodul | Mini-Zentrischspanner
Three-jaw chuck | Collet module | Mini-self centering vise

| | | | | | |
|-----------------------|-----------------------|----------------------|-----------------------|----------------------|------------------|
| | | | | | |
| PS3X125L87BSET | PS3X100L82BSET | PS3X80L75BSET | PS1X50N62-ER32 | PCZ80L40PRG62 | PCZ100L50 |





3 Niederzugspannmodule / Pull down clamp modules

| 48  | | 78  | | 94  | |
|---|---|---|--|--|--|
| PS1R48N34 B80N  | PS1R48N49 B80N  | PS1R78N49 B90R78  | PS1F48N49 B90F78  | PS1R94N49 B90  | PS1F94N49 B90  |
| PCSET18-N1 | PCSET18-N2 | PCSET18-N5 | PCSET18-N6 | PCSET18-N7 | PCSET18-N8 |
| PS1F48N34 B80N  | PS1F48N49 B80N  | <p>F = glatt / flat R = geriffelt / double serrated = Direktprägebacken / Direct stamping</p>  | | PS1R94N49 B93  | |
| PCSET18-N3 | PCSET18-N4 | | | PCSET18-N9 | |

Linearspannmodule / Linear clamp modules

| | | | | | |
|--|--|---|--|--|--|
| PS1 PF 48L34 B115P  | PS1 PF 48L49 B115P  | PS1R78L34 B141  | PS1F78L34 B140  | PS1 PF 94L34 B120P  | PS1 PF 94L49 B120P  |
| PCSET18-L1 | PCSET18-L2 | PCSET18-L5 | PCSET18-L6 | PCSET18-L9 | PCSET18-L11 |
| PS1R48L49 B106  | PS1F48L49 B105  | PS1R78L49 B141  | PS1F78L49 B140  | PS1R94L34 B111  | PS1F94L34 B110  |
| PCSET18-L3 | PCSET18-L4 | PCSET18-L7 | PCSET18-L8 | PCSET18-L12 | PCSET18-L13 |
| PS1R48L34 B106  | PS1F48L34 B105  | <p>Bei jedem Niederzug und Linear Spannmodul sind 2 Parallelunterlagen nach Ihrer Wahl und 1 Fräsanschlag enthalten.  </p> <p>Each pull-down and linear clamping module includes 2 parallels of your choice and 1 milling buffer.</p> | | PS1R94L49 B111  | PS1F94L49 B110  |
| PCSET18-L16 | PCSET18-L17 | | | PCSET18-L14 | PCSET18-L15 |

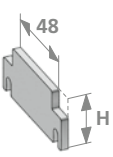
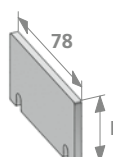
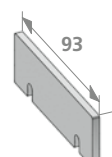
4 Parallelunterlagen / Steel parallels

| 48  | 78  | 94  |
|--|--|--|
|  PCU29047 H PCU 20 047 PCU 24 047 PCU29047 PCU 31 047 PCU 34 047 PCU 39 047 PCU 44 047 PCU 46 047 B48- ... |  PCU39077 H PCU 20 077 PCU 24 077 PCU 29 077 PCU 31 077 PCU 34 077 PCU39077 PCU 44 077 PCU 46 077 B78- ... |  PCU29093 H PCU 14 093 PCU 20 093 PCU 24 093 PCU29093 PCU 31 093 PCU 34 093 PCU 39 093 PCU 44 093 PCU 46 093 PCU 47 093 B94- ... |
| <p>Fräsanschlag / Milling buffer  1 x Inklusive / Included</p> | | |

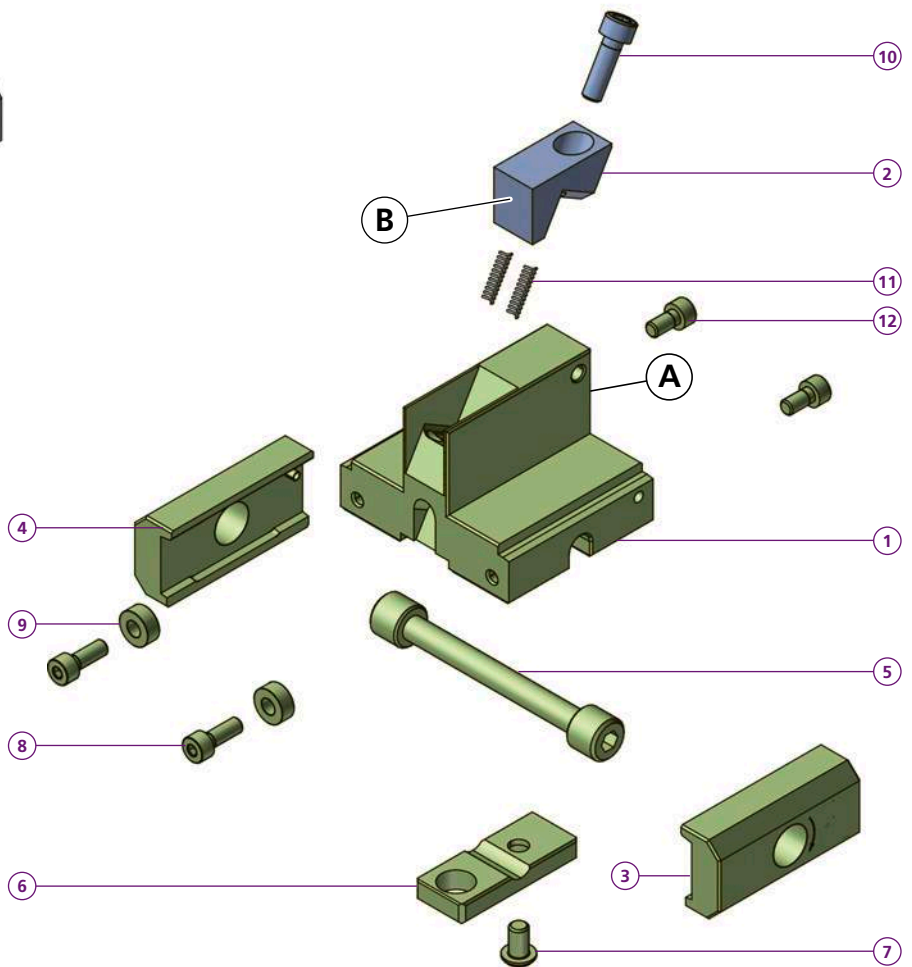
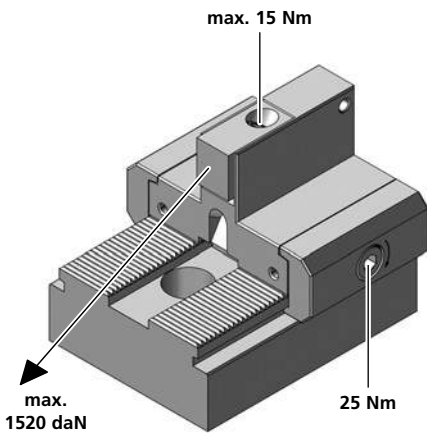
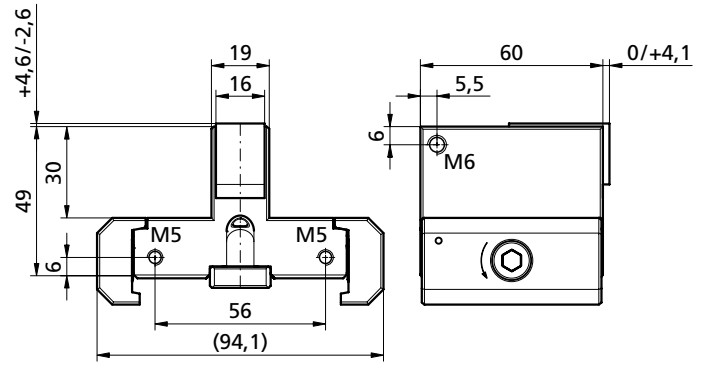
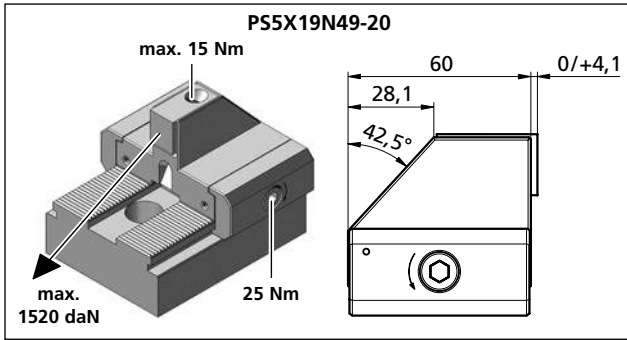

| | |
|----|---------------------|
| | PS5X19N49-20 |
| 1 | 1x TF140449 |
| 9 | 2x PCD005 |
| 8 | 2x M5X14ISO4762 |
| kg | ~1,1 |
| | PS1F19N49-20 |
| 1 | 1x TF150961 |
| | PS1R19N49-20 |
| 1 | 1x TF140448 |
| 2 | 1x |
| 3 | 1x PCSP60R |
| 4 | 1x PCSP60L |
| 5 | 1x PCS14 |
| 6 | 1x PCGU2049 |
| 7 | 1x M6X8ISO7380 |
| 8 | 2x M5X14ISO4762 |
| 9 | 2x PCD005 |
| 10 | 1x M6X20ISO4762 |
| 11 | 2x FED0418 |
| 12 | 2x M5X10ISO4762 |
| kg | ~1,2 |

Bestellbeispiel / Ordering example: 1x PS1R19N49-20 & 1x B21

| | B20 | B21 | B22 |
|----|--------|--------|-------|
| C | 16 | 16 | 16 |
| H | 20 | 20 | 20 |
| L | 19 | 19 | 19 |
| D | 6,5 | 6,5 | 6,5 |
| ø | 12 | 12 | 12 |
| i | HV700 | HV700 | * |
| | x0,2mm | x0,2mm | |
| kg | ~0,06 | ~0,06 | ~0,06 |

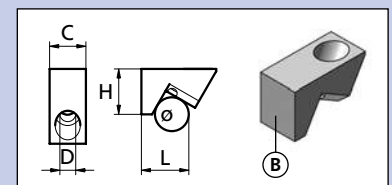

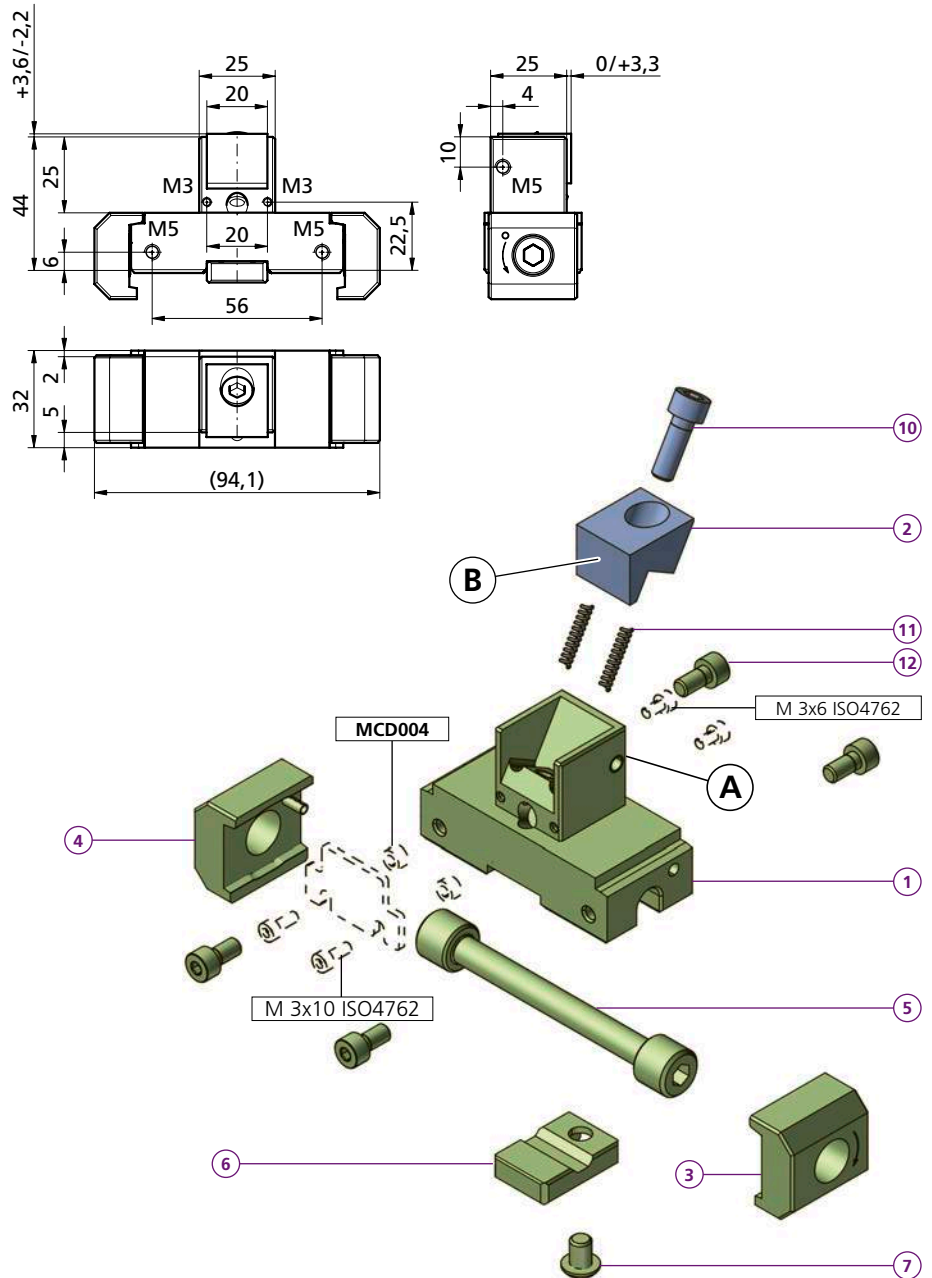
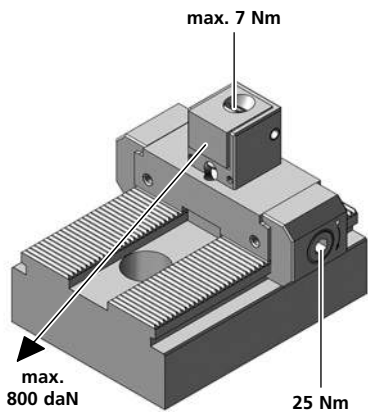

| PS1F25N44-13 | |
|--------------|-----------------|
| 1 | 1x TF150960 |
| PS1R25N44-13 | |
| 1 | 1x TF140450 |
| 2 | 1x |
| 3 | 1x PCSP30R |
| 4 | 1x PCSP30L |
| 5 | 1x PCS14 |
| 6 | 1x PCGU2030 |
| 7 | 1x M6X8ISO7380 |
| 10 | 1x M6X16ISO4762 |
| 11 | 2x FED03018 |
| 12 | 4x M5X10ISO4762 |
| kg | ~0,6 |

| Bestellbeispiel / Ordering example: 1x PS1R25N44-13 & 1x B14 | | | | |
|--|--------|--------|-------|-------|
| | B13 | B14 | B15 | B16 |
| C | 20 | 20 | 20 | 20 |
| H | 16 | 16 | 16 | 16 |
| L | 13,8 | 13,8 | 13,8 | 19 |
| D | 6,5 | 6,5 | 6,5 | 6,5 |
| e | 10 | 10 | 10 | 10 |
| i | HV700 | HV700 | * | * |
| | x0,2mm | x0,2mm | | |
| kg | ~0,05 | ~0,05 | ~0,05 | ~0,06 |

| | H | B | N | kg |
|----------|------|----|---|--------|
| MCU11037 | 11 | 23 | 2 | ~0,004 |
| MCU15037 | 15 | 23 | 2 | ~0,006 |
| MCU18037 | 18 | 23 | 2 | ~0,008 |
| MCU20037 | 20 | 23 | 2 | ~0,008 |
| MCU22537 | 22,5 | 23 | 2 | ~0,008 |

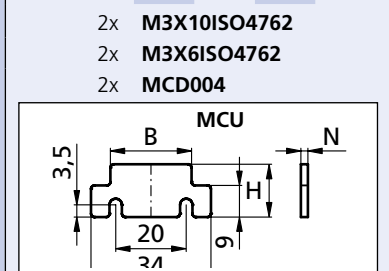

- 2x M3X10ISO4762
- 2x M3X6ISO4762
- 2x MCD004

* = weicher Stahl / soft steel

Separat bestellen / Order separately

PS1R/F26N49-26

PS5X26N49-26

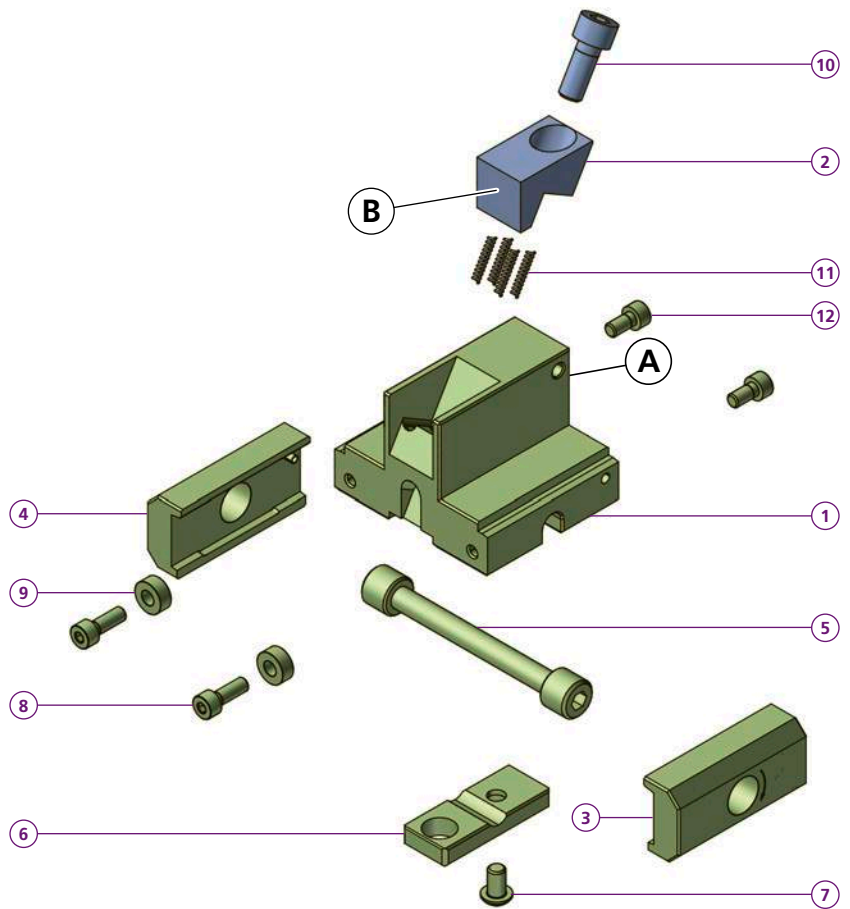
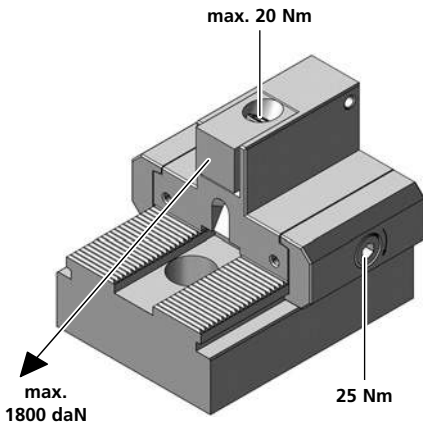
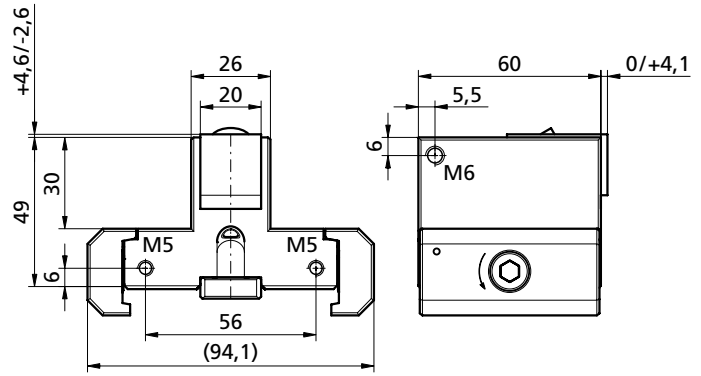
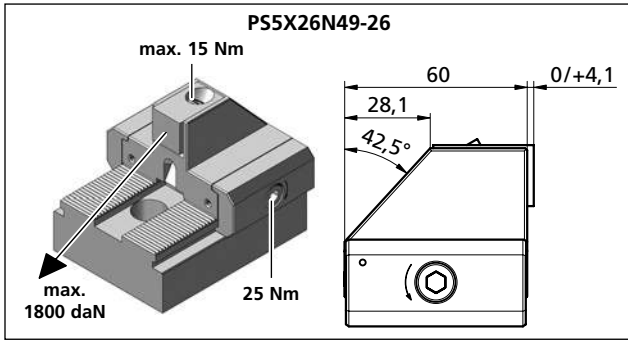

| | |
|---------------------|-----------------|
| PS5X26N49-26 | |
| 1 | 1x TF140453 |
| 9 | 2x PCD005 |
| 8 | 2x M5X14ISO4762 |
| kg | ~1,1 |
| PS1F26N49-26 | |
| 1 | 1x TF140451 |
| PS1R26N49-26 | |
| 1 | 1x TF140452 |
| 2 | 1x |
| 3 | 1x PCSP60R |
| 4 | 1x PCSP60L |
| 5 | 1x PCS14 |
| 6 | 1x PCGU2049 |
| 7 | 1x M6X8ISO7380 |
| 8 | 2x M5X14ISO4762 |
| 9 | 2x PCD005 |
| 10 | 1x M8X20ISO4762 |
| 11 | 4x FED0418 |
| 12 | 2x M5X10ISO4762 |
| kg | ~1,2 |

| | | | |
|-----------|------------|------------|------------|
| B | B26 | B27 | B28 |
| C | 20 | 20 | 20 |
| H | 20 | 20 | 20 |
| L | 19 | 19 | 19 |
| D | 9 | 9 | 9 |
| e | 12 | 12 | 12 |
| i | HV700 | HV700 | * |
| | x0,2mm | x0,2mm | |
| kg | ~0,07 | ~0,07 | ~0,07 |

Bestellbeispiel / Ordering example: 1x PS1R26N49-26 & 1x B26

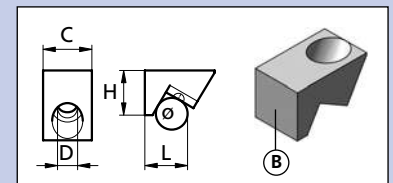

Separat bestellen / Order separately

PS1R/F34N49-45

PS5X34N49-45

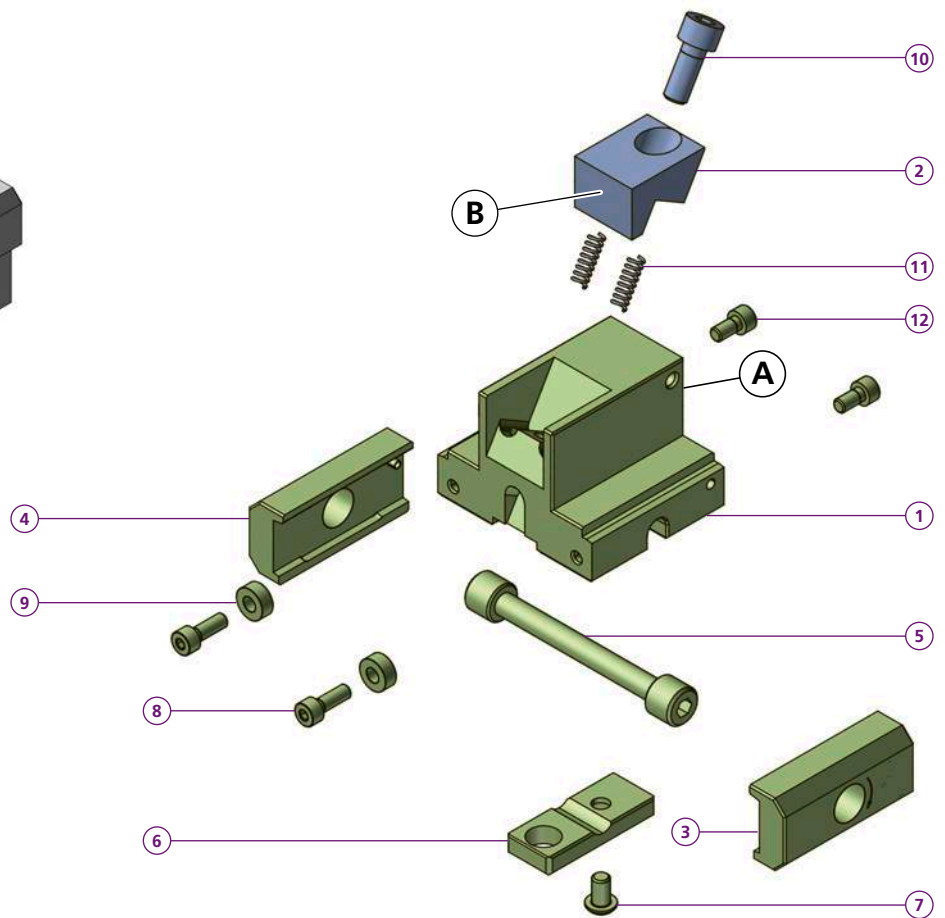
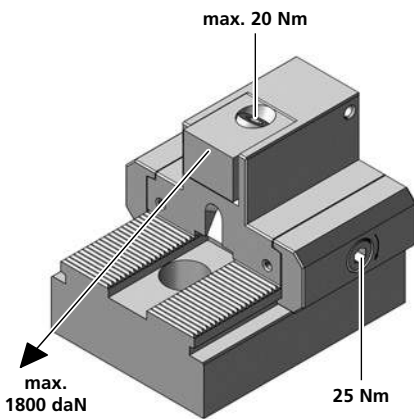
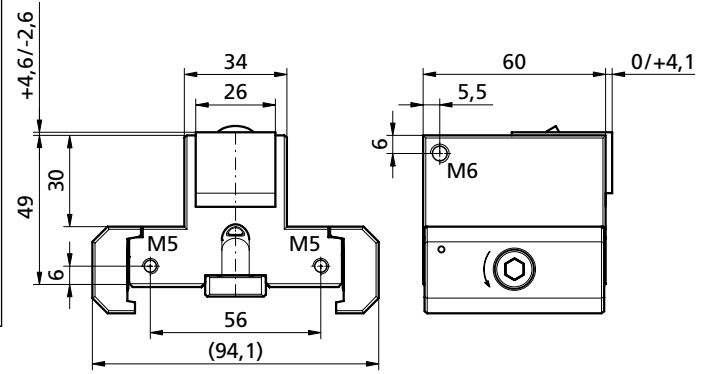
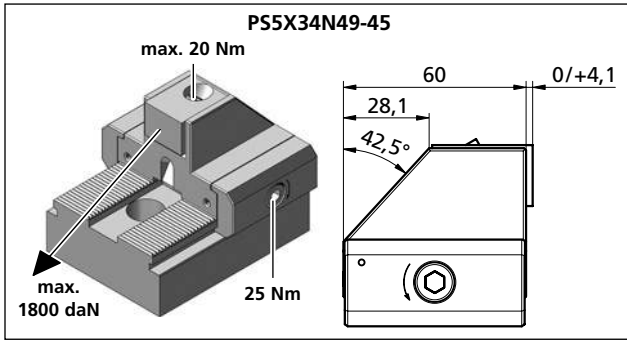

| | |
|---------------------|-----------------|
| PS5X34N49-45 | |
| 1 | 1x TF140455 |
| 9 | 2x PCD005 |
| 8 | 2x M5X14ISO4762 |
| kg | ~1,2 |
| PS1F34N49-45 | |
| 1 | 1x TF191071 |
| PS1R34N49-45 | |
| 1 | 1x TF140454 |
| 2 | 1x |
| 3 | 1x PCSP60R |
| 4 | 1x PCSP60L |
| 5 | 1x PCS14 |
| 6 | 1x PCGU2049 |
| 7 | 1x M6X8ISO7380 |
| 8 | 2x M5X14ISO4762 |
| 9 | 2x PCD005 |
| 10 | 1x M8X20ISO4762 |
| 11 | 2x FED0618 |
| 12 | 2x M5X10ISO4762 |
| kg | ~1,3 |

Bestellbeispiel / Ordering example: 1x **PS5X34N49-45** & 1x **B47HM**

| | B45 | B46 | B47 | B47HM |
|----|--------|--------|------|-------|
| C | 26 | 26 | 26 | 26 |
| H | 20 | 20 | 20 | 20 |
| L | 19 | 19 | 19,1 | 19,1 |
| D | 9 | 9 | 9 | 9 |
| e | 12 | 12 | 12 | 12 |
| i | HV700 | HV700 | * | HM |
| | x0,2mm | x0,2mm | | |
| kg | ~0,1 | ~0,1 | ~0,1 | ~0,1 |

* = weicher Stahl / soft steel

HM = Hartmetallbeschichtet / Carbide coated

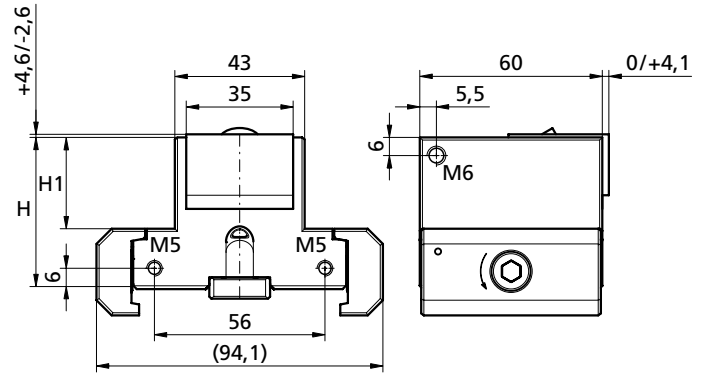
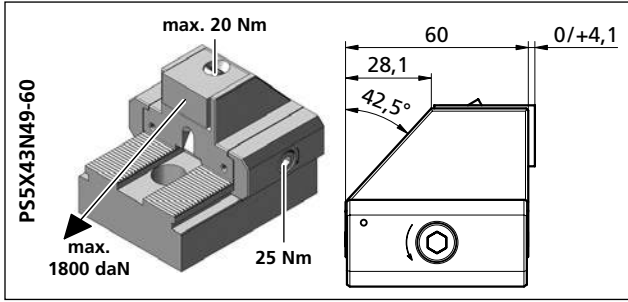

- PS5X43N49-60**
- 1x TF140458
 - 2x PCD005
 - 2x M5X14ISO4762
- kg ~1,3
- PS1F43N49-60**
- 1x TF140456
- PS1R43N49-60**
- 1x TF140457
 - 1x PCSP60R
 - 1x PCSP60L
 - 1x PCS14
 - 1x PCGU2049
 - 1x M6X8ISO7380
 - 2x M5X14ISO4762
 - 2x PCD005
 - 1x M8X20ISO4762
 - 2x FED0618
 - 2x M5X10ISO4762
- H = 49
H1 = 30
kg ~1,4
- PS1F43N62-60**
- 1x TF140459
- PS1R43N62-60**
- 1x TF140460
- H = 62
H1 = 43
kg ~1,7

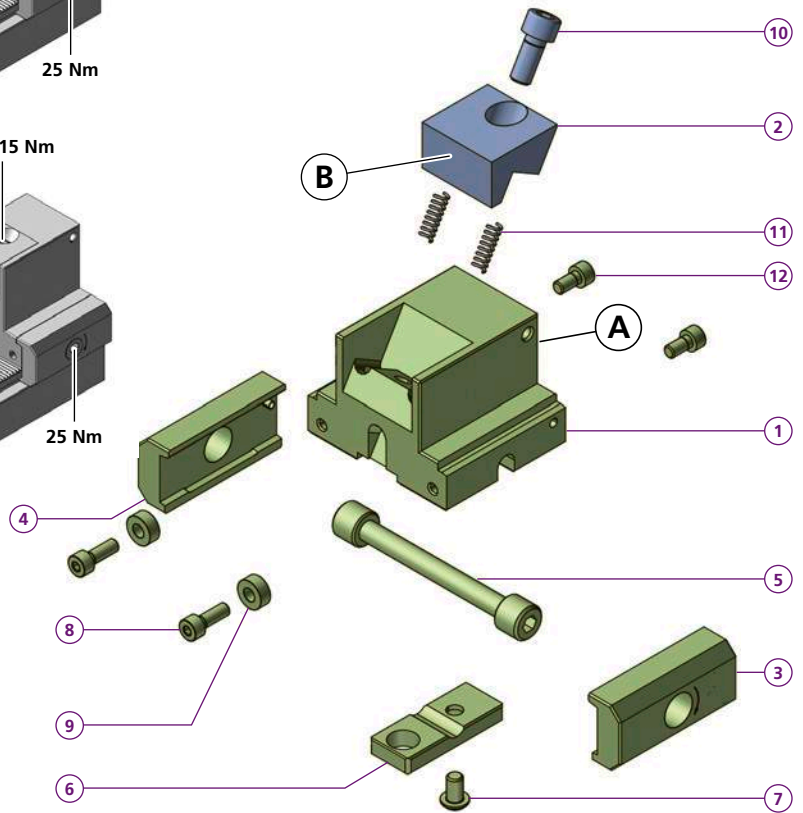
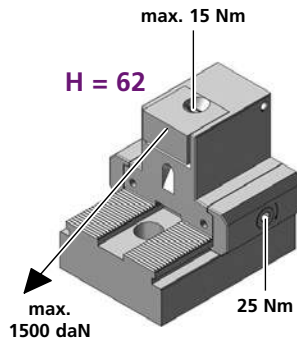
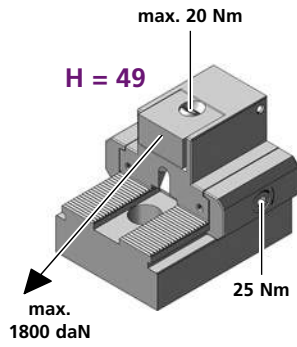

Bestellbeispiel / Ordering example: 1x PS1R43N49-60 & 1x B61

| | B58 | B60 | B61 | B62 | B62HM | B65 | B66 | B67 | B68 | B69 | B77 | B79F | B79R |
|----|-------|-------|-------|-------|-------|-----------------|-----------------|-----------------|-------|-------|-------|-----------------|-----------------|
| C | 35 | 35 | 35 | 35 | 35 | 35 | 35 | 35 | 35 | 35 | 35 | 35 | 35 |
| H | 20 | 20 | 20 | 20 | 20 | 20 | 20 | 20 | 20 | 25 | 20 | 20 | 20 |
| L | 26 | 19 | 19 | 19 | 19 | 19 | 19 | 24 | 26 | 22 | 22 | 25 | 25 |
| D | 9 | 9 | 9 | 9 | 9 | 9 | 9 | 9 | 9 | 9 | 9 | 9 | 9 |
| o | 12 | 12 | 12 | 12 | 12 | 12 | 12 | 12 | 12 | 12 | 12 | 12 | 12 |
| i | ALU | 56HRC | 56HRC | * | HM | HV700 x0,2mm | HV700 x0,2mm | HV700 x0,2mm | * | * | 56HRC | HV700 x0,2mm | HV700 x0,2mm |
| kg | ~0,07 | ~0,12 | ~0,12 | ~0,12 | ~0,12 | ~0,12 | ~0,12 | ~0,14 | ~0,15 | ~0,15 | ~0,12 | ~0,18 | ~0,18 |

B58

B60, B61, B62, B62HM

B65, B66, B67

B68

B77

B79F, B79R

B69
M5X10ISO4762
+11,5/-0,7
0/+7

FED 0628

Separat bestellen / Order separately

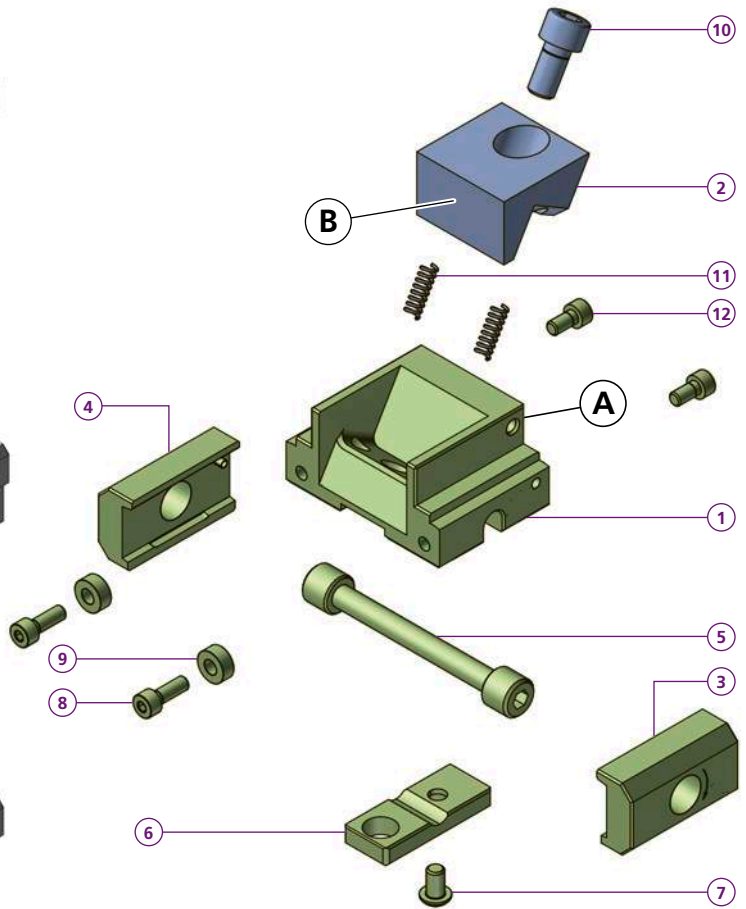
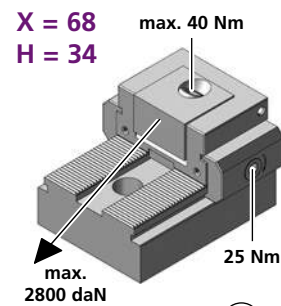
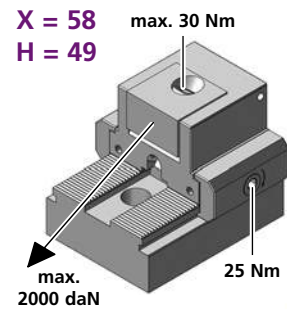
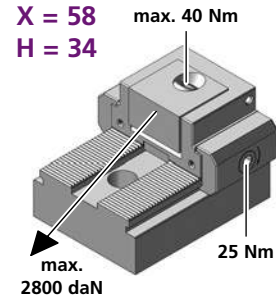
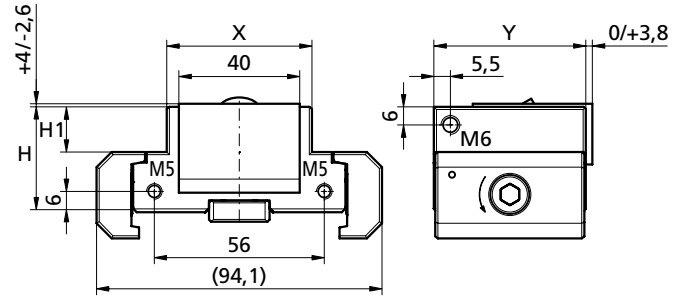
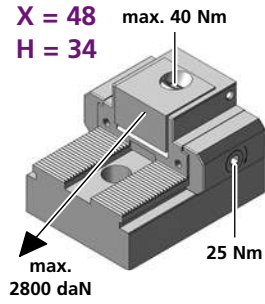

- PS1F48N34-80**
- 1 1x TF140461
- PS1R48N34-80**
- 1 1x TF140462
 - 2 1x
 - 3 1x PCSP50R
 - 4 1x PCSP50L
 - 5 1x PCS14
 - 6 1x PCGU2049
 - 7 1x M6X8ISO7380
 - 8 2x M5X14ISO4762
 - 9 2x PCD005
 - 10 1x M10X25ISO4762
 - 11 2x FED0618
 - 12 2x M5X10ISO4762
- X = 48
H = 34
H1 = 15
Y = 50
kg ~0,9

- PS1F58N34-80**
- 1 1x TF140463
- PS1R58N34-80**
- 1 1x TF140464
- X = 58
H = 34
H1 = 15
Y = 50
kg ~0,9

- PS1R58N49-80**
- 1 1x TK120129
 - 3 1x PCSP60R
 - 4 1x PCSP60L
- X = 58
H = 49
H1 = 30
Y = 60
kg ~1,6

- PS1F68N34-80**
- 1 1x TF140465
- PS1R68N34-80**
- 1 1x TF140466
- X = 68
H = 34
H1 = 15
Y = 50
kg ~1,0

Bestellbeispiel / Ordering example: 1x PS1F68N34-80 & 1x B82HM

| | B80 | B80N | B81 | B82 | B82L33 | B82HM | B83 | B84 | B89F | B89R |
|----|-------|-----------------|-------|------|--------|-------|-----------------|------|-----------------|-----------------|
| C | 40 | 40 | 40 | 40 | 40 | 40 | 40 | 40 | 40 | 40 |
| H | 25 | 25 | 25 | 25 | 25 | 25 | 25 | 25 | 25 | 25 |
| L | 22 | 22 | 22 | 22,2 | 33 | 22,2 | 22 | 26,3 | 29 | 29 |
| D | 11 | 11 | 11 | 11 | 11 | 11 | 11 | 11 | 11 | 11 |
| ø | 15 | 15 | 15 | 15 | 15 | 15 | 15 | 15 | 15 | 15 |
| i | 56HRC | HV700 x0,2mm | 56HRC | * | * | 56HRC | HV700 x0,2mm | * | HV700 x0,2mm | HV700 x0,2mm |
| kg | ~0,2 | ~0,2 | ~0,2 | ~0,2 | ~0,28 | ~0,2 | ~0,2 | ~0,2 | ~0,24 | ~0,24 |

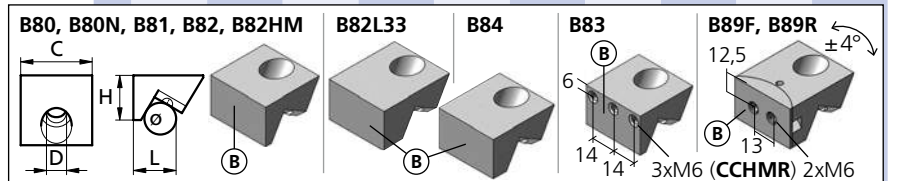

* = weicher Stahl / soft steel

HM = Hartmetallbeschichtet / Carbide coated

Separat bestellen / Order separately

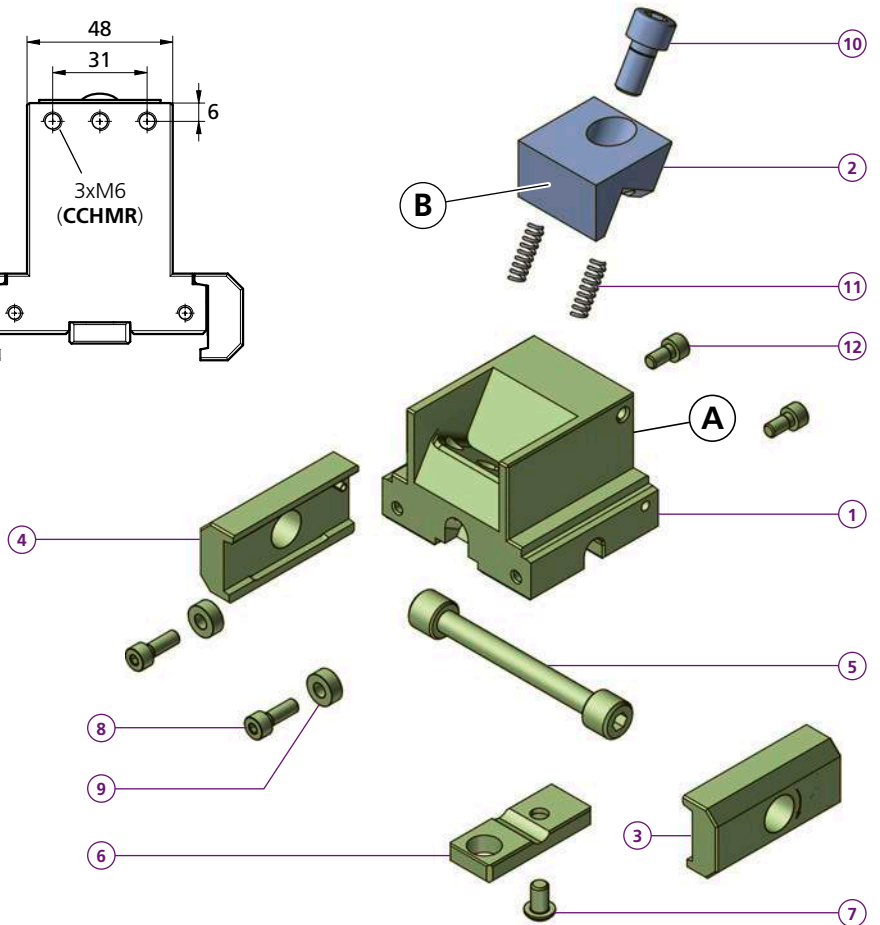
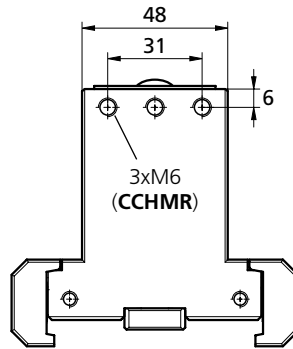
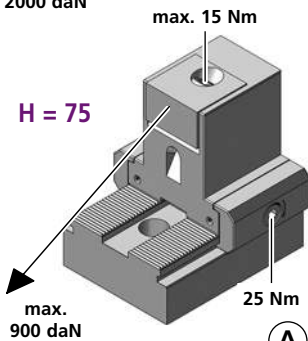
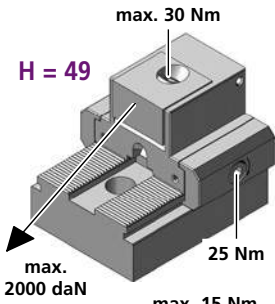
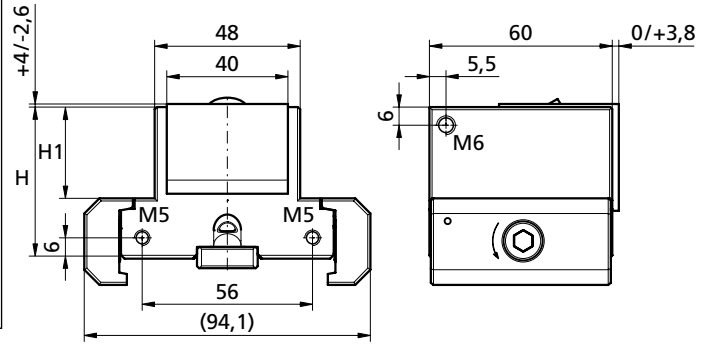
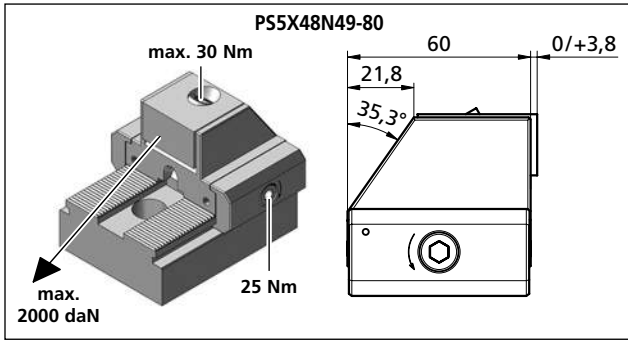

| |
|---------------------|
| PS5X48N49-80 |
| 1 1x TF140469 |
| 9 2x PCD005 |
| 8 2x M5X14ISO4762 |
| kg ~1,3 |
| PS1F48N49-80 |
| 1 1x TF140467 |
| PS1R48N49-80 |
| 1 1x TF140468 |
| 2 1x |
| 3 1x PCSP60R |
| 4 1x PCSP60L |
| 5 1x PCS14 |
| 6 1x PCGU2049 |
| 7 1x M6X8ISO7380 |
| 8 2x M5X14ISO4762 |
| 9 2x PCD005 |
| 10 1x M10X25ISO4762 |
| 11 2x FED0618 |
| 12 2x M5X10ISO4762 |
| H = 49 |
| H1 = 30 |
| kg ~1,4 |

| |
|---------------------|
| PS1R48N75-80 |
| 1 1x TF140471 |
| H = 75 |
| H1 = 56 |
| kg ~2,0 |

Bestellbeispiel / Ordering example: 1x PS1F48N49-80 & 1x B80

| | B80 | B80N | B81 | B82 | B82L33 | B82HM | B83 | B84 | B89F | B89R |
|----|-------|-----------------|-------|------|--------|-------|-----------------|------|-----------------|-----------------|
| C | 40 | 40 | 40 | 40 | 40 | 40 | 40 | 40 | 40 | 40 |
| H | 25 | 25 | 25 | 25 | 25 | 25 | 25 | 25 | 25 | 25 |
| L | 22 | 22 | 22 | 22,2 | 33 | 22,2 | 22 | 26,3 | 29 | 29 |
| D | 11 | 11 | 11 | 11 | 11 | 11 | 11 | 11 | 11 | 11 |
| ø | 15 | 15 | 15 | 15 | 15 | 15 | 15 | 15 | 15 | 15 |
| i | 56HRC | HV700 x0,2mm | 56HRC | * | * | 56HRC | HV700 x0,2mm | * | HV700 x0,2mm | HV700 x0,2mm |
| kg | ~0,2 | ~0,2 | ~0,2 | ~0,2 | ~0,28 | ~0,2 | ~0,2 | ~0,2 | ~0,24 | ~0,24 |

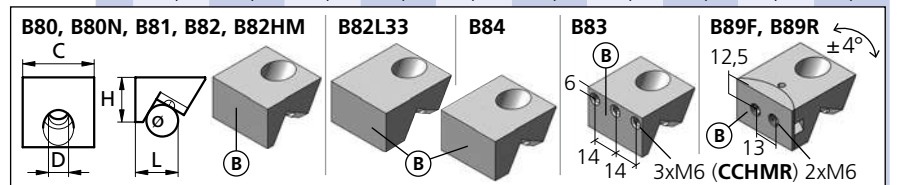

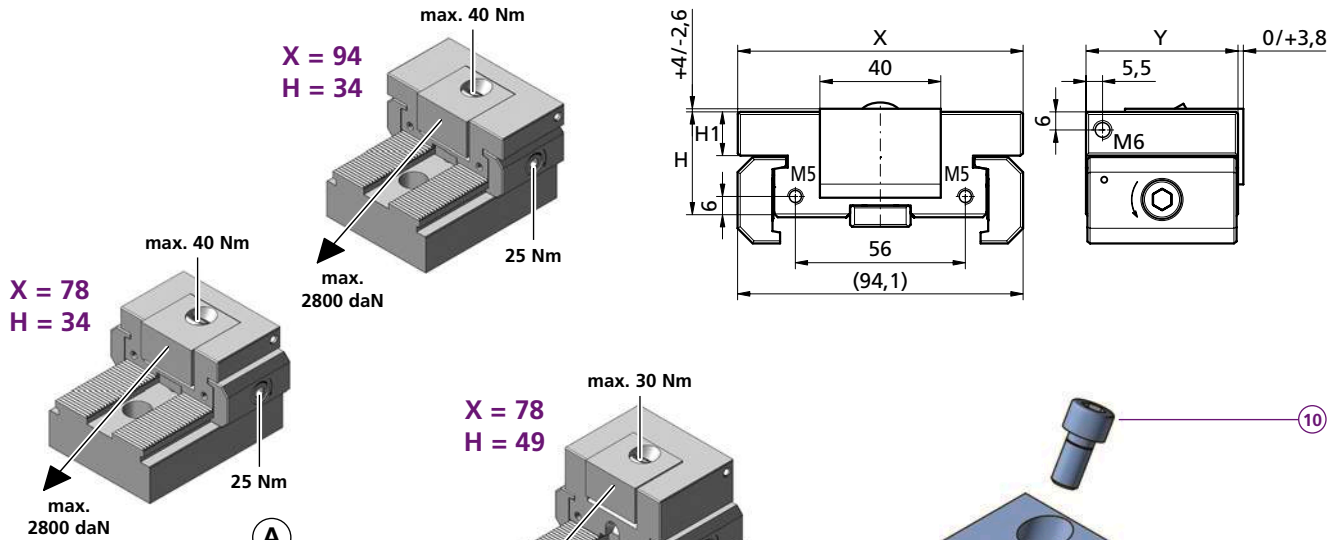

- PS1F78N34-80**
- 1 1x TF140472
- PS1R78N34-80**
- 1 1x TF140473
 - 2 1x [Material Icon]
 - 3 1x PCSP50R
 - 4 1x PCSP50L
 - 5 1x PCS14
 - 6 1x PCGU2049
 - 7 1x M6X8ISO7380
 - 8 2x M5X14ISO4762
 - 9 2x PCD005
 - 10 1x M10X25ISO4762
 - 11 2x FED0618
 - 12 2x M5X10ISO4762
- X = 48
H = 34
H1 = 15
Y = 50
kg ~1,1

- PS1F94N34-80**
- 1 1x TF140476
- PS1R94N34-80**
- 1 1x TF140477
- X = 94
H = 34
H1 = 15
Y = 50
kg ~1,1

- PS1F78N49-80**
- 1 1x TF140474
- PS1R78N49-80**
- 1 1x TF140475
 - 3 1x PCSP60R
 - 4 1x PCSP60L
- X = 78
H = 49
H1 = 30
Y = 60
kg ~1,8

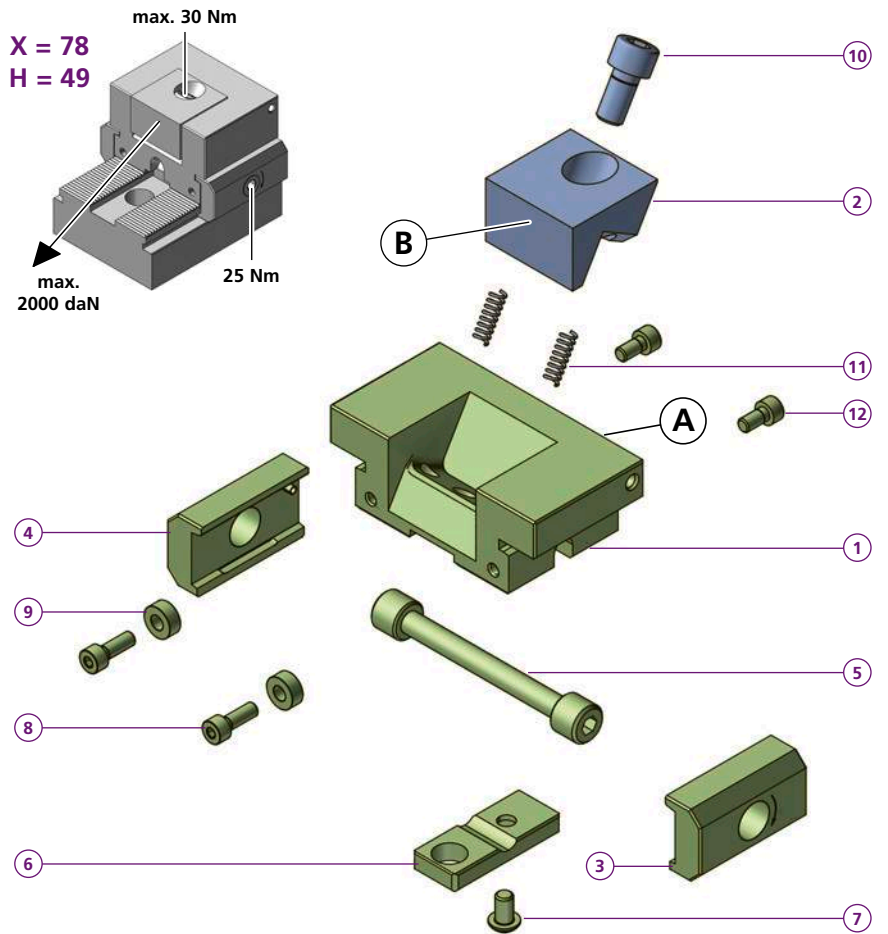

Bestellbeispiel / Ordering example: 1x PS1R94N34-80 & 1x B80

| | B80 | B80N | B81 | B82 | B82L33 | B82HM | B83 | B84 | B89F | B89R |
|----|-------|-----------------|-------|------|--------|-------|-----------------|------|-----------------|-----------------|
| C | 40 | 40 | 40 | 40 | 40 | 40 | 40 | 40 | 40 | 40 |
| H | 25 | 25 | 25 | 25 | 25 | 25 | 25 | 25 | 25 | 25 |
| L | 22 | 22 | 22 | 22,2 | 33 | 22,2 | 22 | 26,3 | 29 | 29 |
| D | 11 | 11 | 11 | 11 | 11 | 11 | 11 | 11 | 11 | 11 |
| ø | 15 | 15 | 15 | 15 | 15 | 15 | 15 | 15 | 15 | 15 |
| i | 56HRC | HV700 x0,2mm | 56HRC | * | * | 56HRC | HV700 x0,2mm | * | HV700 x0,2mm | HV700 x0,2mm |
| kg | ~0,2 | ~0,2 | ~0,2 | ~0,2 | ~0,28 | ~0,2 | ~0,2 | ~0,2 | ~0,24 | ~0,24 |

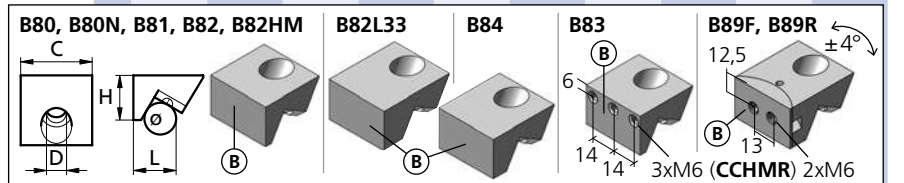

* = weicher Stahl / soft steel

HM = Hartmetallbeschichtet / Carbide coated

Separat bestellen / Order separately

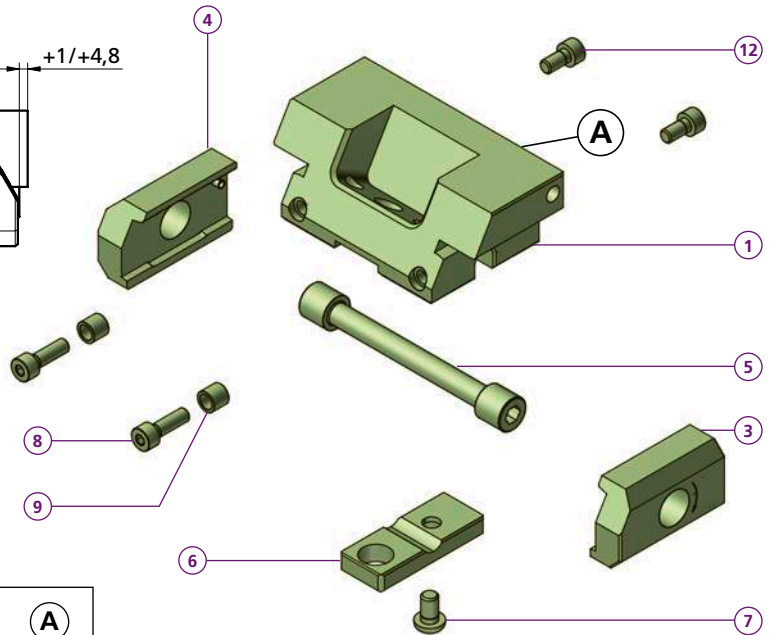
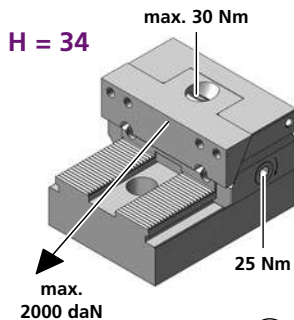
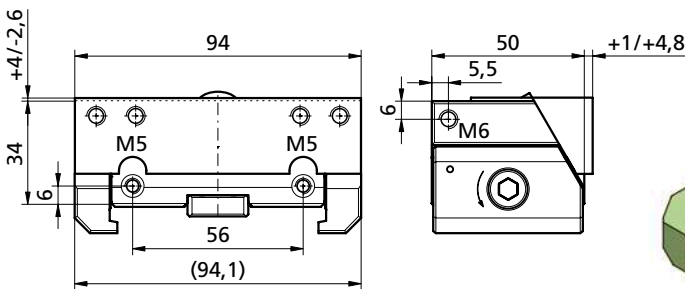
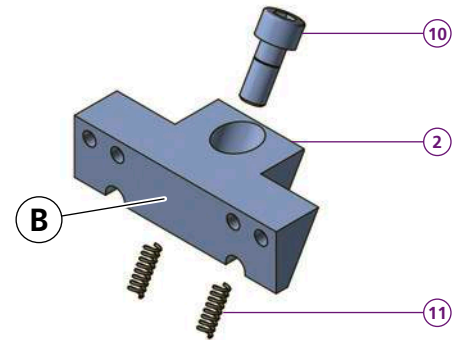
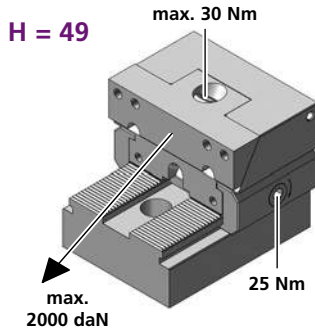
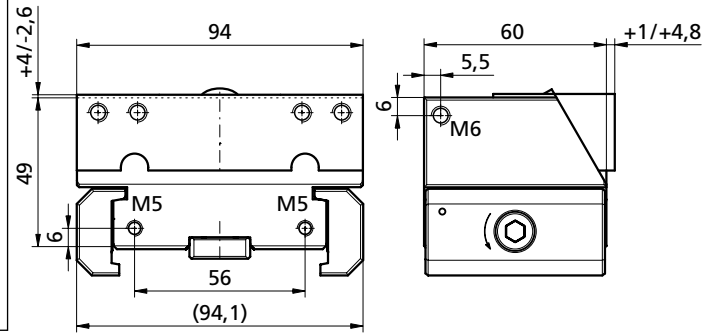
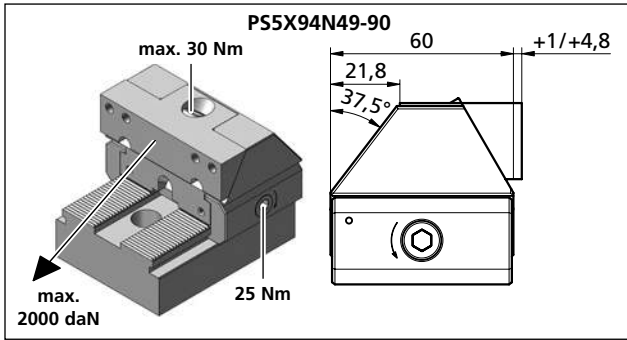

| PS1F94N34-90 | | PS1R94N34-90 | | PS5X94N49-90 | |
|--------------|------------------|--------------|-----------------|--------------|-----------------|
| 1 | 1x TF140478 | 1 | 1x TF140479 | 1 | 1x TF140482 |
| 2 | 1x | 2 | 1x | 3 | 1x PCSP60R |
| 3 | 1x PCSP50RF | 3 | 1x PCSP60L | 4 | 1x PCSP60L |
| 4 | 1x PCSP50LF | 9 | 2x PCD005 | 9 | 2x PCD005 |
| 5 | 1x PCS14 | 8 | 2x M5X14ISO4762 | 8 | 2x M5X14ISO4762 |
| 6 | 1x PCGU2049 | kg | ~1,8 | kg | ~1,8 |
| 7 | 1x M6X8ISO7380 | PS1F94N49-90 | | PS1R94N49-90 | |
| 8 | 2x M5X16ISO4762 | 1 | 1x TF140480 | 1 | 1x TF140481 |
| 9 | 2x PCD008 | 2 | 1x | 2 | 1x |
| 10 | 1x M10X25ISO4762 | 3 | 1x PCSP60R | 3 | 1x PCSP60R |
| 11 | 2x FED0618 | 4 | 1x PCSP60L | 4 | 1x PCSP60L |
| 12 | 2x M5X10ISO4762 | 8 | 2x M5X14ISO4762 | 8 | 2x M5X14ISO4762 |
| H | = 34 | 9 | 2x PCD005 | 9 | 2x PCD005 |
| kg | ~1,0 | H | = 49 | H | = 49 |
| | | kg | ~2,0 | kg | ~2,0 |

Bestellbeispiel / Ordering example:
1x PS1F94N34-90 & 1x B91

| | B90 | B91 | B92 | B93 | B94 |
|----|-----------------|-----------------|-------|-----------------|-------|
| C | 94 | 94 | 94 | 94 | 94 |
| H | 25 | 25 | 25 | 25 | 25 |
| L | 23 | 23 | 23 | 23 | 40 |
| D | 11 | 11 | 11 | 11 | 11 |
| e | 15 | 15 | 15 | 15 | 15 |
| i | HV700 x0,2mm | HV700 x0,2mm | * | HV700 x0,2mm | * |
| kg | ~0,33 | ~0,33 | ~0,33 | ~0,33 | ~0,64 |

Separat bestellen / Order separately

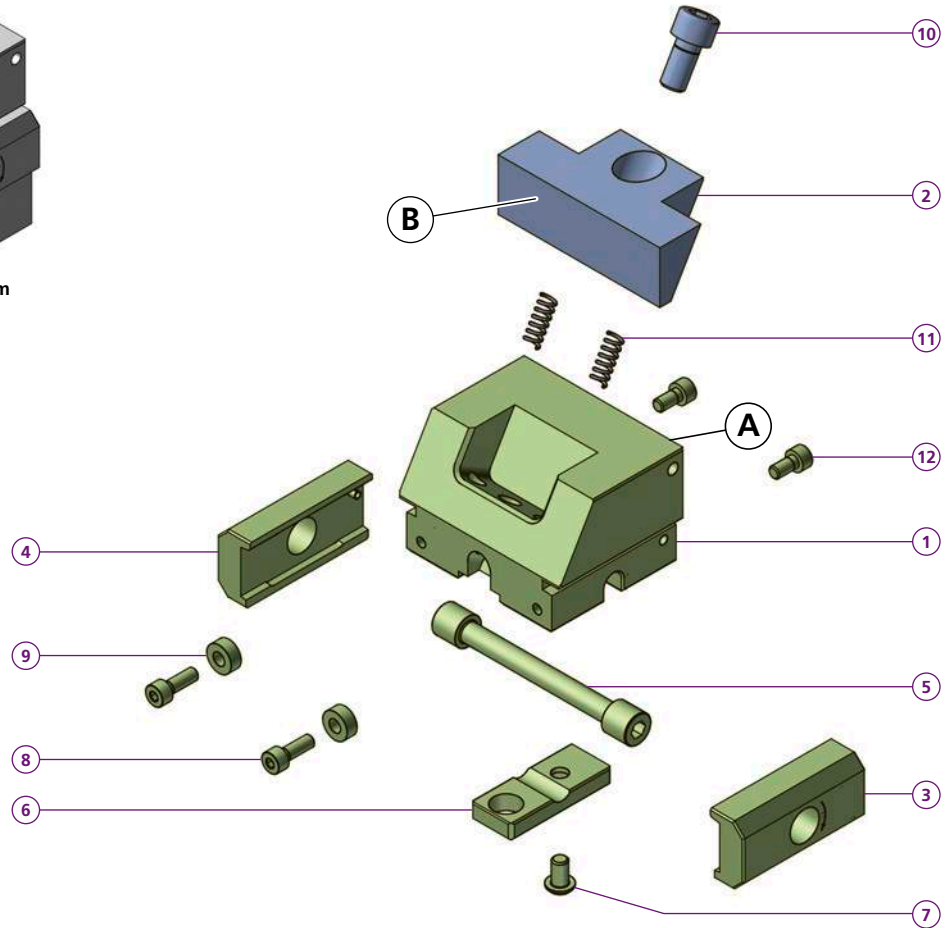
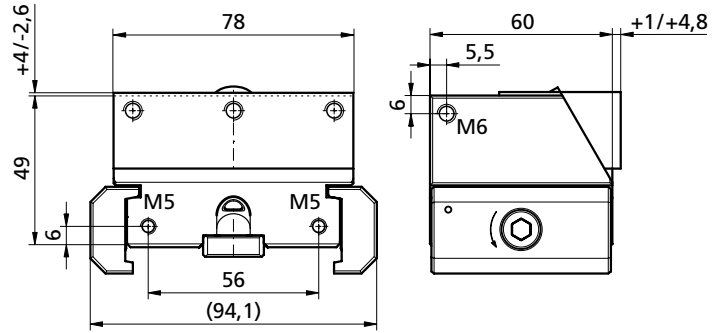
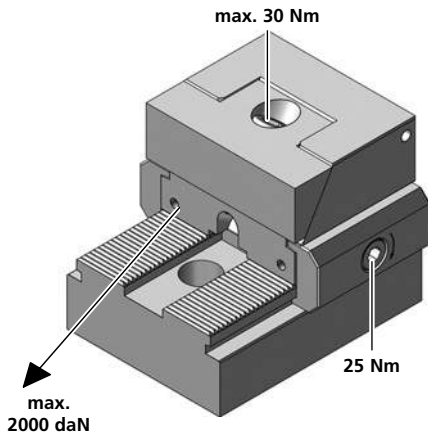

| | |
|---------------------|------------------|
| PS1F78N49-90 | |
| 1 | 1x TH160490 |
| PS1R78N49-90 | |
| 1 | 1x TH160490 |
| 2 | 1x |
| 3 | 1x PCSP60R |
| 4 | 1x PCSP60L |
| 5 | 1x PCS14 |
| 6 | 1x PCGU2049 |
| 7 | 1x M6X8ISO7380 |
| 8 | 2x M5X14ISO4762 |
| 9 | 2x PCD005 |
| 10 | 1x M10X25ISO4762 |
| 11 | 2x FED0618 |
| 12 | 2x M5X10ISO4762 |
| kg | ~1,8 |

Bestellbeispiel / Ordering example:
1x PS1F78N49-90 & 1x B90F78

| | B90F78 | B90W78 | B90R78 |
|----|--------|--------|--------|
| C | 78 | 78 | 78 |
| H | 25 | 25 | 25 |
| L | 23 | 28 | 23 |
| D | 11 | 11 | 11 |
| e | 15 | 15 | 15 |
| i | HV700 | * | HV700 |
| | x0,2mm | | x0,2mm |
| kg | ~0,3 | ~0,37 | ~0,3 |

| | |
|-----------------------|--------------|
| B90F78, B90W78 | |
| | |
| | 3xM6 (CCHMR) |

* = weicher Stahl / soft steel

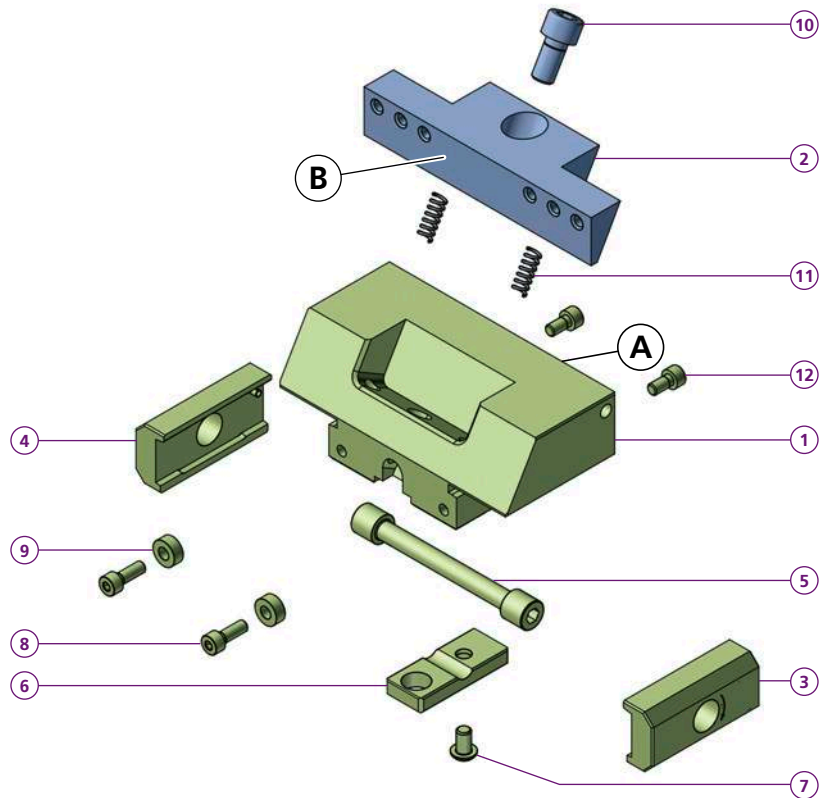
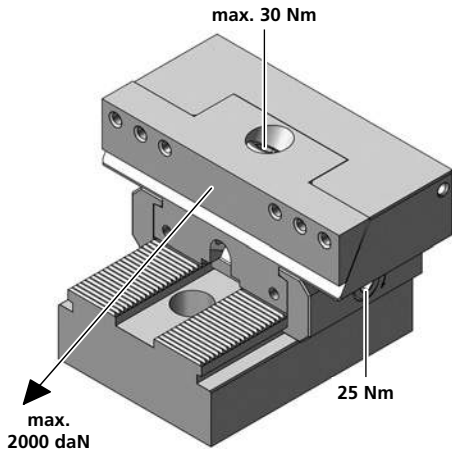
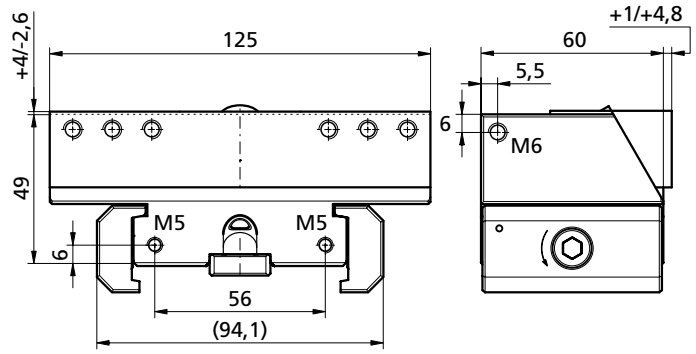
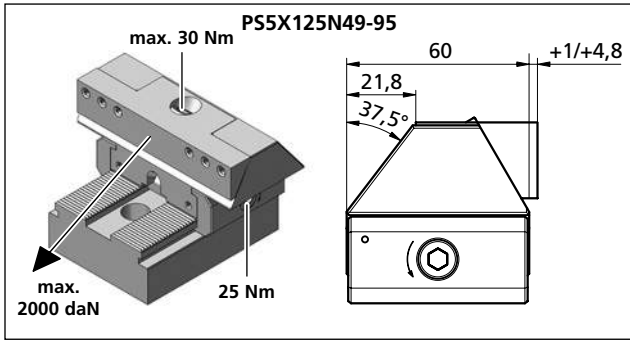

| | |
|--------------|----------------------|
| 37,5° | PS5X125N49-95 |
| 1 | 1x TF140485 |
| 9 | 2x PCD005 |
| 8 | 2x M5X14ISO4762 |
| kg | ~2,0 |
| | PS1F125N49-95 |
| 1 | 1x TF140483 |
| | PS1R125N49-95 |
| 1 | 1x TF140484 |
| 2 | 1x — |
| 3 | 1x PCSP60R |
| 4 | 1x PCSP60L |
| 5 | 1x PCS14 |
| 6 | 1x PCGU2049 |
| 7 | 1x M6X8ISO7380 |
| 8 | 2x M5X14ISO4762 |
| 9 | 2x PCD005 |
| 10 | 1x M10X25ISO4762 |
| 11 | 2x FED0618 |
| 12 | 2x M5X10ISO4762 |
| kg | ~2,3 |

Bestellbeispiel / Ordering example: 1x PS5X125N49-95 & 1x B95

| | B95 | B96 | B97 | B98 | B99 |
|----|--------|--------|-------|-------|--------|
| C | 125 | 125 | 125 | 125 | 125 |
| H | 25 | 25 | 25 | 25 | 25 |
| L | 23 | 23 | 23 | 30 | 23 |
| D | 11 | 11 | 11 | 11 | 11 |
| ø | 15 | 15 | 15 | 15 | 15 |
| i | HV700 | HV700 | * | * | HV700 |
| | x0,2mm | x0,2mm | | | x0,2mm |
| kg | ~0,46 | ~0,45 | ~0,46 | ~0,63 | ~0,45 |

| B95, B96, B97, B99 | | B98 | |
|--------------------|--|-----|--|
| | | | |
| 6xM6 (CCHMR) | | 110 | |
| | | 84 | |
| | | 58 | |
| | | 6 | |

Separat bestellen / Order separately

PS2G94N44-13

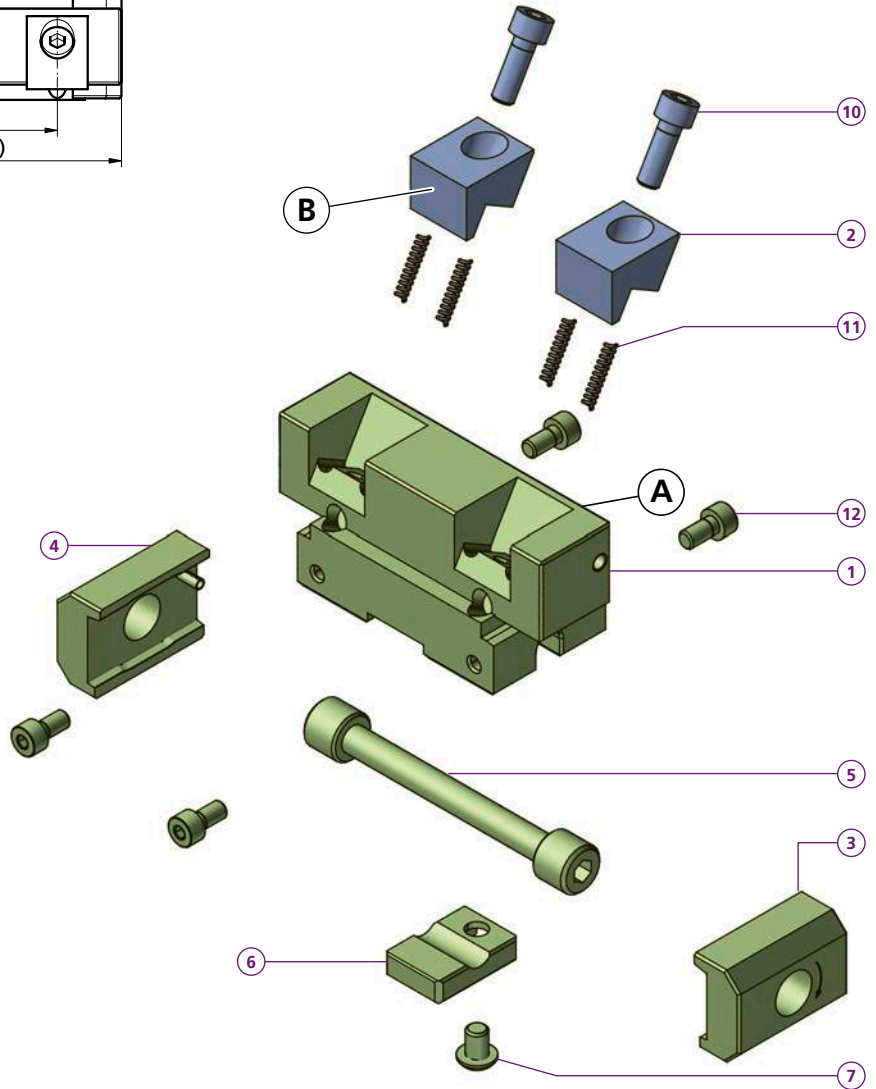
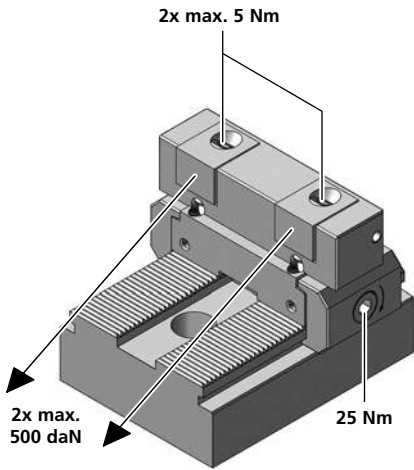
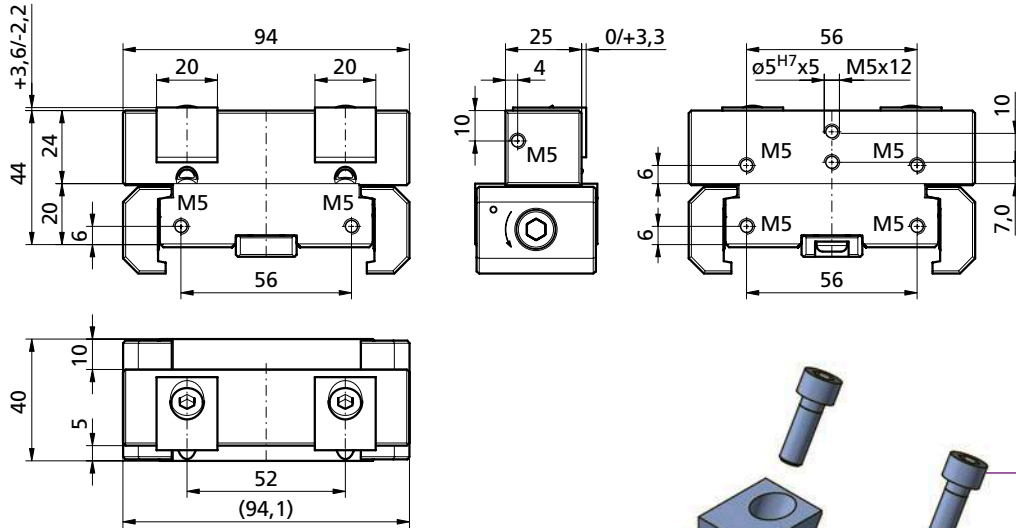

| PS2G94N44-13 | |
|--------------|-----------------|
| 1 | 1x TF140486 |
| 2 | 2x |
| 3 | 1x PCSP40R |
| 4 | 1x PCSP40L |
| 5 | 1x PCS14 |
| 6 | 1x PCGU2030 |
| 7 | 1x M6X8ISO7380 |
| 10 | 2x M6X16ISO4762 |
| 11 | 4x FED0318 |
| 12 | 4x M5X10ISO4762 |
| kg | ~1,0 |

| | B13 | B14 | B15 | B16 |
|----|--------|--------|-------|-------|
| C | 20 | 20 | 20 | 20 |
| H | 16 | 16 | 16 | 16 |
| L | 13,8 | 13,8 | 13,8 | 19 |
| D | 6,5 | 6,5 | 6,5 | 6,5 |
| ø | 10 | 10 | 10 | 10 |
| i | HV700 | HV700 | * | * |
| | x0,2mm | x0,2mm | | |
| kg | ~0,05 | ~0,05 | ~0,05 | ~0,06 |

Bestellbeispiel / Ordering example: 1x PS2G94N44-13 & 2x B14

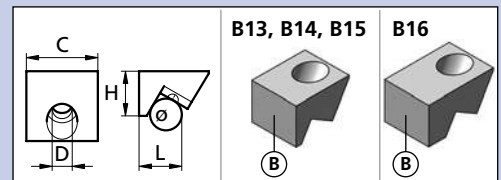

* = weicher Stahl / soft steel

Separat bestellen / Order separately

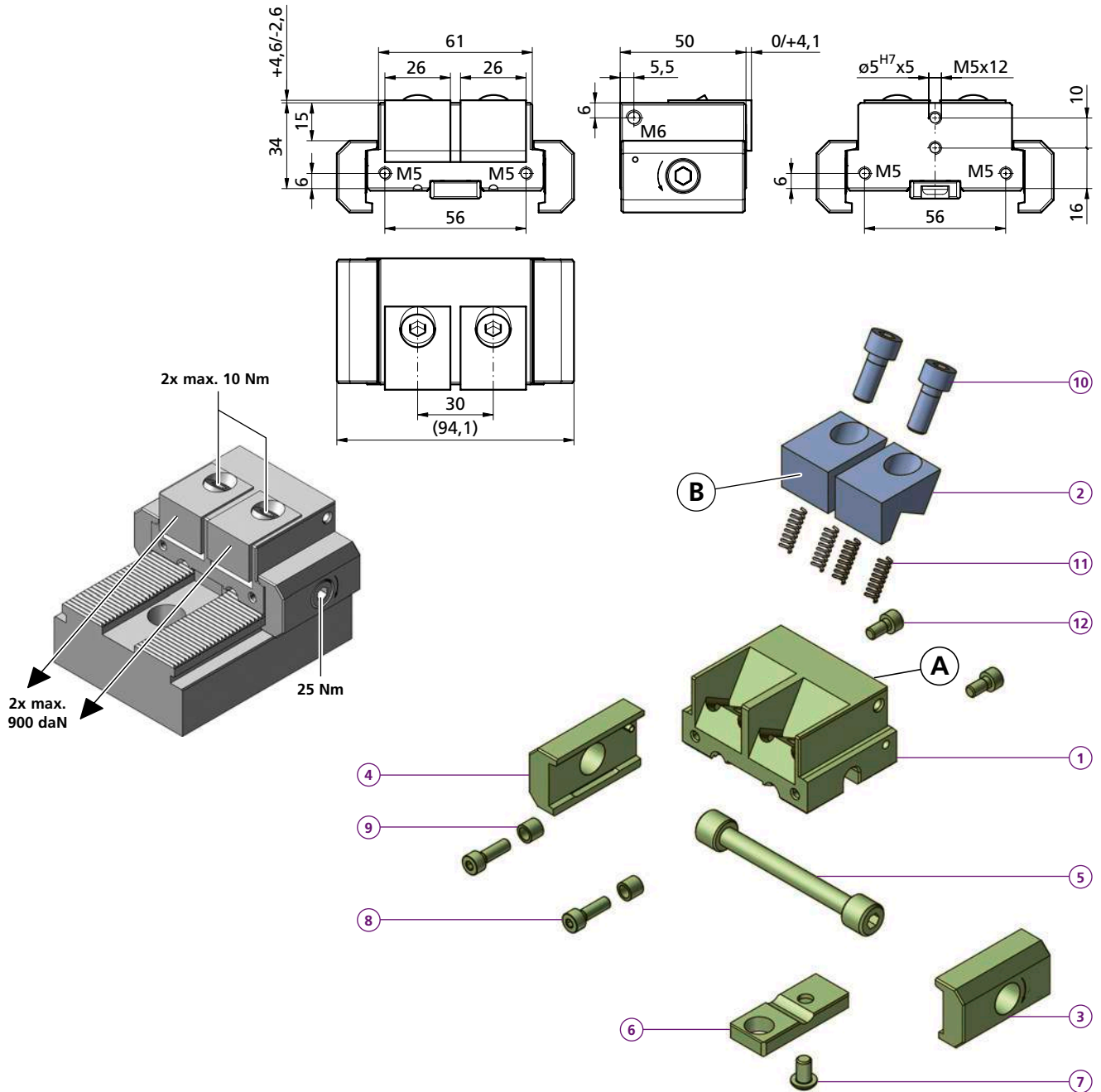

| | |
|----------|---------------------|
| A | PS2F61N34-45 |
| 1 | 1x TF140487 |
| A | PS2R61N34-45 |
| 1 | 1x TF140488 |
| 2 | 2x |
| 3 | 1x PCSP50R |
| 4 | 1x PCSP50L |
| 5 | 1x PCS14 |
| 6 | 1x PCGU2049 |
| 7 | 1x M6X8ISO7380 |
| 8 | 2x M5X16ISO4762 |
| 9 | 2x PCD008 |
| 10 | 2x M8X20ISO4762 |
| 11 | 4x FED0618 |
| 12 | 2x M5X10ISO4762 |
| kg | ~1,0 |

Bestellbeispiel / Ordering example: 1x PS2R61N34-45 & 2x B47HM

| | B45 | B46 | B47 | B47HM |
|-----------|------------|------------|------------|--------------|
| C | 26 | 26 | 26 | 26 |
| H | 20 | 20 | 20 | 20 |
| L | 19 | 19 | 19,1 | 19,1 |
| D | 9 | 9 | 9 | 9 |
| e | 12 | 12 | 12 | 12 |
| i | HV700 | HV700 | * | HM |
| | x0,2mm | x0,2mm | | |
| kg | ~0,1 | ~0,1 | ~0,1 | ~0,1 |

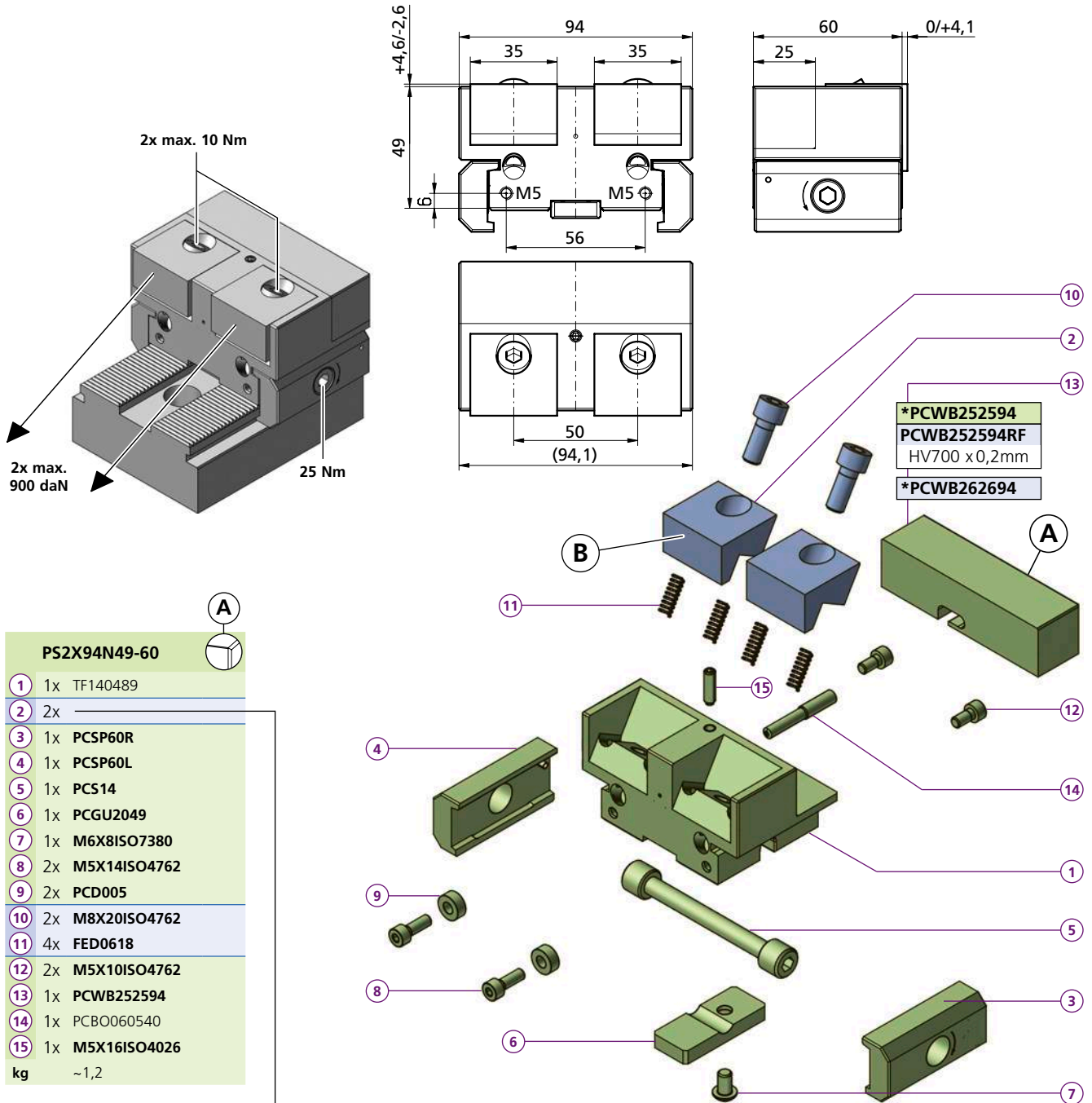

PS2X94N49-60

| | | |
|----|----|--------------|
| 1 | 1x | TF140489 |
| 2 | 2x | |
| 3 | 1x | PCSP60R |
| 4 | 1x | PCSP60L |
| 5 | 1x | PCS14 |
| 6 | 1x | PCGU2049 |
| 7 | 1x | M6X8ISO7380 |
| 8 | 2x | M5X14ISO4762 |
| 9 | 2x | PCD005 |
| 10 | 2x | M8X20ISO4762 |
| 11 | 4x | FED0618 |
| 12 | 2x | M5X10ISO4762 |
| 13 | 1x | PCWB252594 |
| 14 | 1x | PCBO060540 |
| 15 | 1x | M5X16ISO4026 |
| kg | | ~1,2 |

Bestellbeispiel / Ordering example: 1x PS2X94N49-60 & 2x B58

| | B58 | B60 | B61 | B62 | B62HM | B65 | B66 | B67 | B68 | B69 | B77 | B79F | B79R |
|----|-------|-------|-------|-------|-------|-----------------|-----------------|-----------------|-------|-------|-------|-----------------|-----------------|
| C | 35 | 35 | 35 | 35 | 35 | 35 | 35 | 35 | 35 | 35 | 35 | 35 | 35 |
| H | 20 | 20 | 20 | 20 | 20 | 20 | 20 | 20 | 20 | 25 | 20 | 20 | 20 |
| L | 26 | 19 | 19 | 19 | 19 | 19 | 19 | 24 | 26 | 22 | 22 | 25 | 25 |
| D | 9 | 9 | 9 | 9 | 9 | 9 | 9 | 9 | 9 | 9 | 9 | 9 | 9 |
| o | 12 | 12 | 12 | 12 | 12 | 12 | 12 | 12 | 12 | 12 | 12 | 12 | 12 |
| i | ALU | 56HRC | 56HRC | * | HM | HV700 x0,2mm | HV700 x0,2mm | HV700 x0,2mm | * | * | 56HRC | HV700 x0,2mm | HV700 x0,2mm |
| kg | ~0,07 | ~0,12 | ~0,12 | ~0,12 | ~0,12 | ~0,12 | ~0,12 | ~0,14 | ~0,15 | ~0,15 | ~0,12 | ~0,18 | ~0,18 |

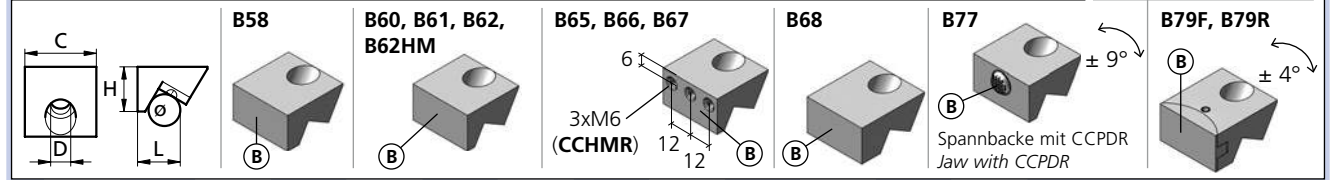
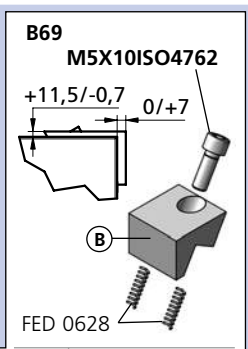

* = weicher Stahl / soft steel HM = Hartmetallbeschichtet / Carbide coated ALU = ENAW-7022

Separat bestellen / Order separately

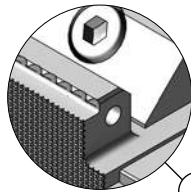
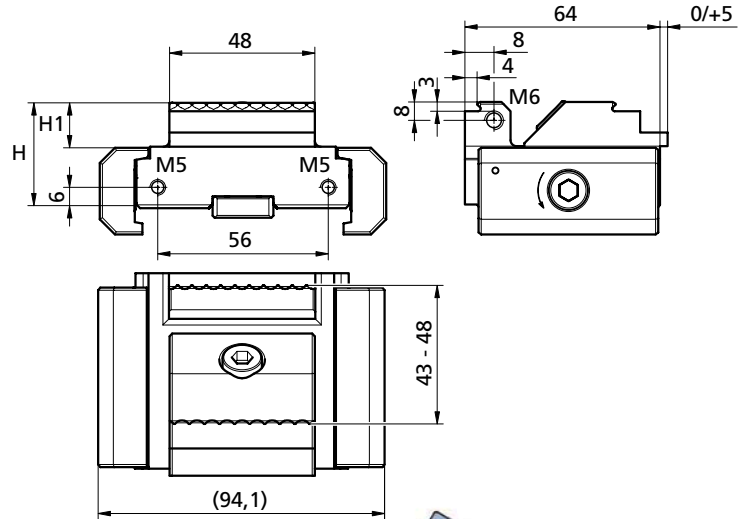
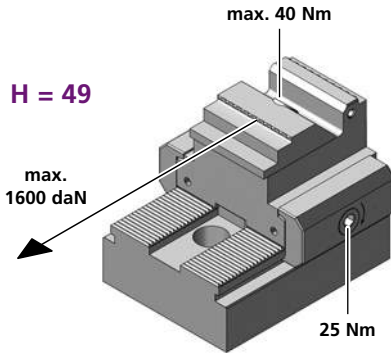
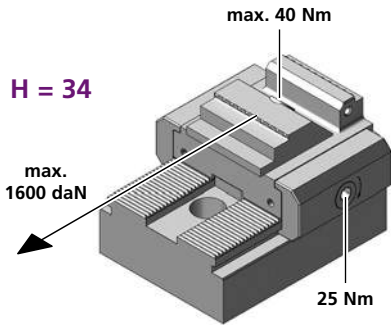

PS1P48L34-105

- 1 1x TW100098-01
- 2 1x
- 3 1x PCSP60R
- 4 1x PCSP60L
- 5 1x PCS14
- 6 1x PCGU2059
- 7 1x M6X8ISO7380
- 8 2x M5X14ISO4762
- 9 2x PCD005
- 10 1x M8X28ISO4762
- 11 1x PCUSR16
- 12 2x M5X10ISO4762
- 13 1x PCKMR45M8
- 14 2x D=6 DIN 5401
- H = 34
- H1 = 15
- kg ~1,0

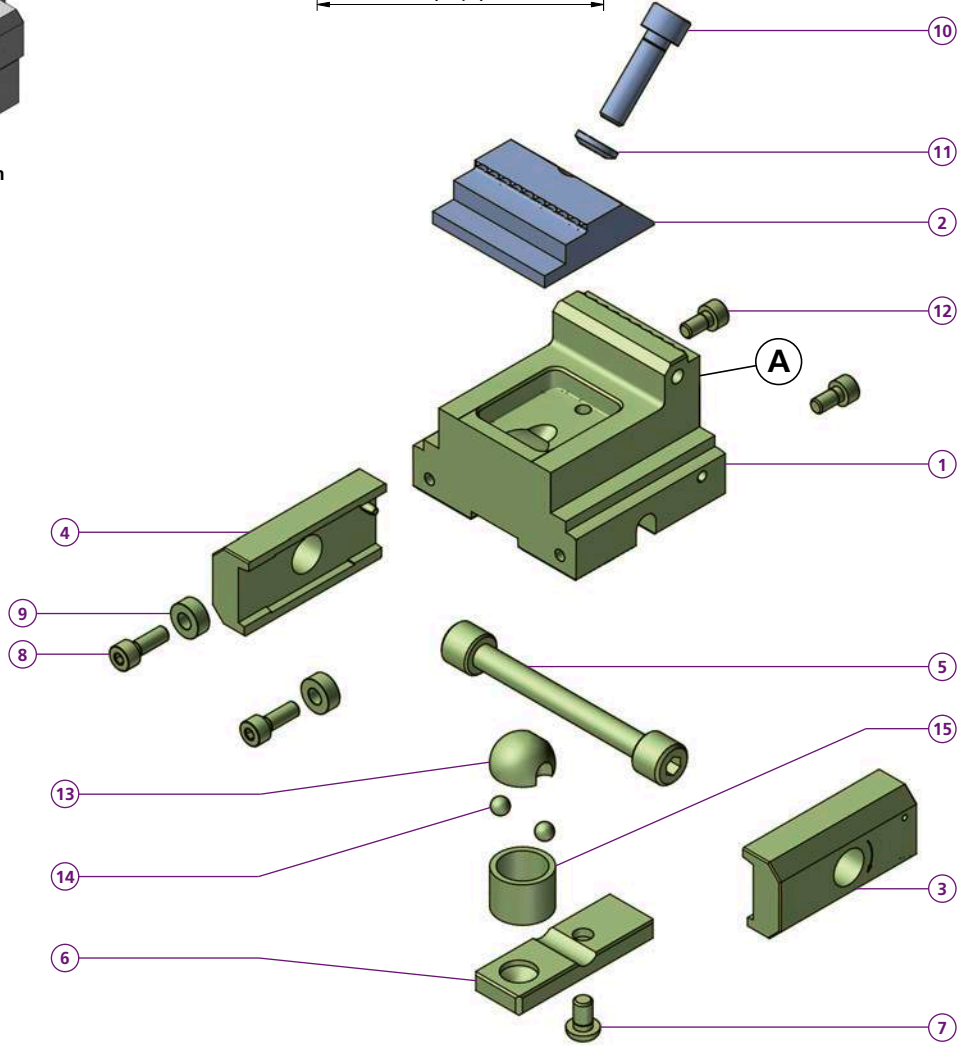

p. 84, 85

PS1PF48L34-105

- 1 1x TK140780
- H = 49
- H1 = 30
- kg ~1,0

PS1P48L49-105

- 1 1x TK120011
- 15 1x PCD20L15
- H = 49
- H1 = 30
- kg ~1,4

PS1PF48L49-105

- 1 1x TK140781
- 15 1x PCD20L15
- H = 49
- H1 = 30
- kg ~1,4

Bestellbeispiel / Ordering example:
1x PS1P48L34-105 & 1x B115

| Drehmoment Torque | | Spannkraft Workholding force | | |
|----------------------|---------|---------------------------------|-------|-----|
| Nm | (lb-ft) | ~daN | ~(lb) | ~t |
| 10 | 7,4 | = 400 | 880 | 0,4 |
| 20 | 14,8 | = 800 | 1'760 | 0,8 |
| 30 | 22,2 | = 1'200 | 2'650 | 1,2 |
| 40 | 29,6 | = 1'600 | 3'530 | 1,6 |

PS1P94L34-105

PS1P694L34-105

PS1P94L49-105

PS1PF94L49-105

PS1PF94L34-105

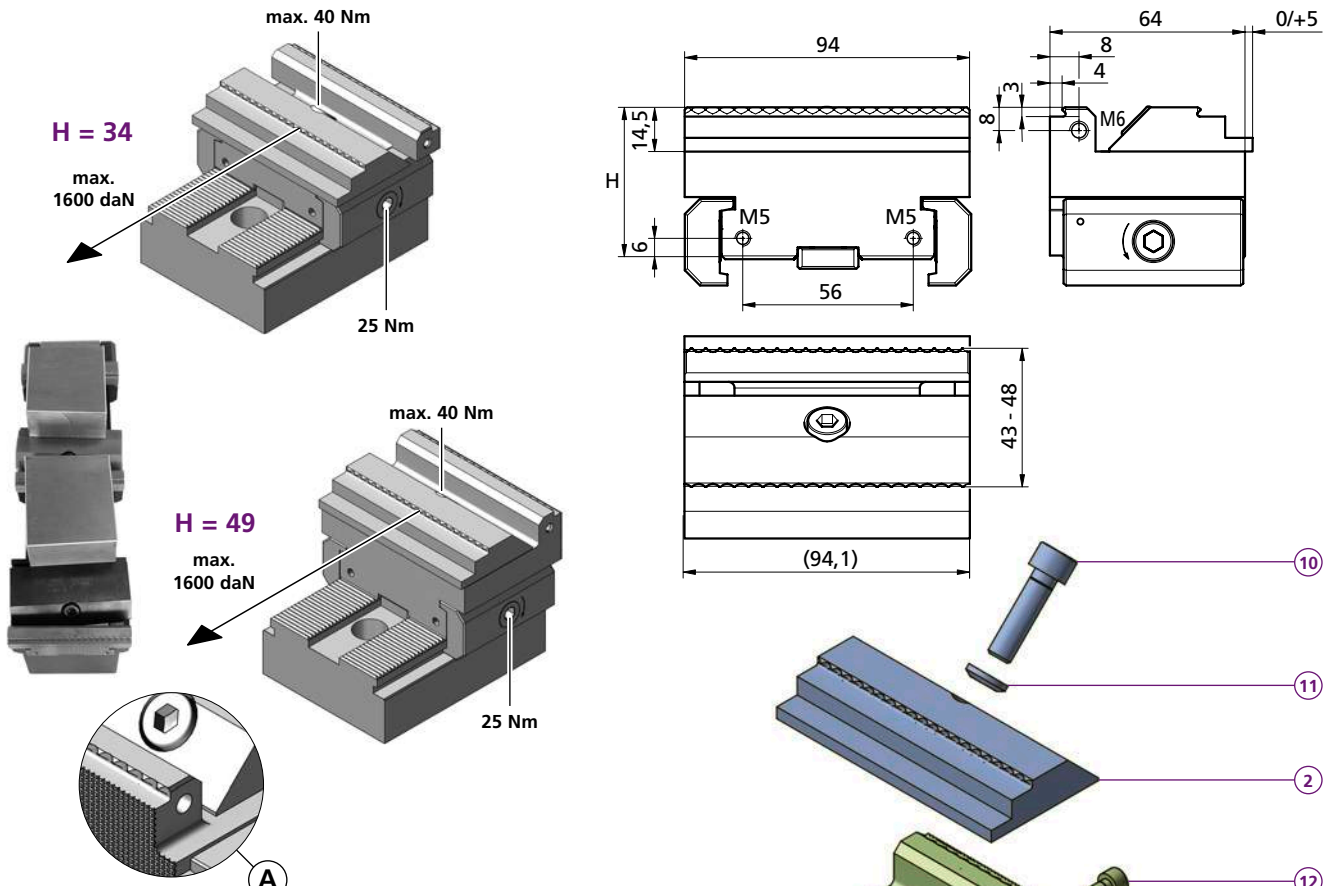

PS1P94L34-105

- 1 1x TW100100-01
- 2 1x
- 3 1x PCSP60R
- 4 1x PCSP60L
- 5 1x PCS14
- 6 1x PCGU2059
- 7 1x M6X8ISO7380
- 8 2x M5X14ISO4762
- 9 2x PCD005
- 10 1x M8X28ISO4762
- 11 1x PCUSR16
- 12 2x M5X10ISO4762
- 13 1x PCKMR45M8
- 14 2x D=6 DIN 5401

H = 34
kg ~1,1

PS1P694L34-105

- 1 1x TW100100-02
- Y 6,0 mm

kg ~1,1

PS1PF94L34-105

- 1 1x TK140782

H = 49
kg ~1,1

p. 84, 85

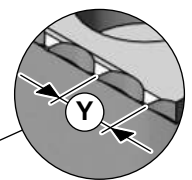

PS1P94L49-105

- 1 1x TK120857
- 15 1x PCD20L15

H = 49
kg ~1,8

PS1PF94L49-105

- 1 1x TK140783
- 15 1x PCD20L15

H = 49
kg ~1,8

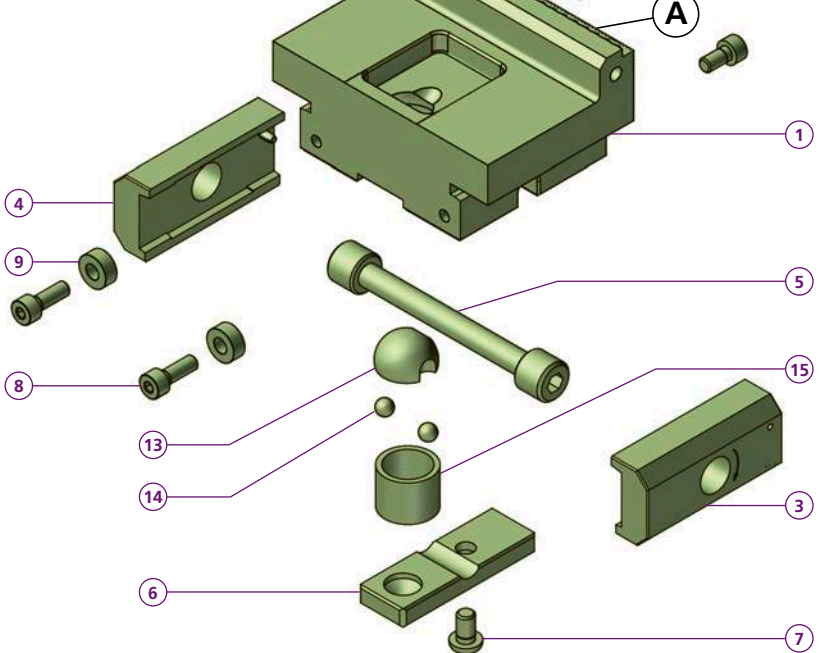

Bestellbeispiel / Ordering example:
1x PS1P94L34-105 & 1x B120

| Drehmoment Torque | | Spannkraft Workholding force | | |
|----------------------|---------|---------------------------------|-------|-----|
| Nm | (lb-ft) | ~daN | ~(lb) | ~t |
| 10 | 7,4 | = 400 | 880 | 0,4 |
| 20 | 14,8 | = 800 | 1'760 | 0,8 |
| 30 | 22,2 | = 1'200 | 2'650 | 1,2 |
| 40 | 29,6 | = 1'600 | 3'530 | 1,6 |

Separat bestellen / Order separately

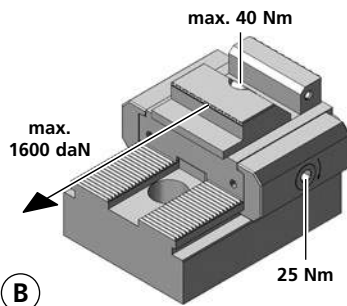
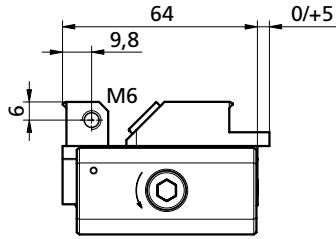
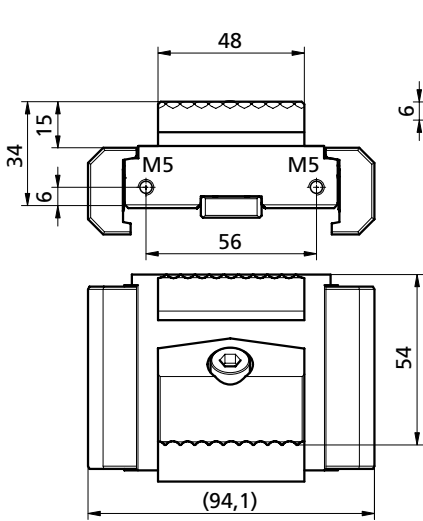

- PS1PV48L34-105**
- 1x TK140762
 - 1x _____
 - 1x PCSP60R
 - 1x PCSP60L
 - 1x PCS14
 - 1x PCGU2059
 - 1x M6X8ISO7380
 - 2x M5X14ISO4762
 - 2x PCD005
 - 1x M8X28ISO4762
 - 1x PCUSR16
 - 2x M5X10ISO4762
 - 1x PCKMR45M8
 - 2x D=6 DIN 5401
- kg ~1,0

B123P

| | |
|----|-------|
| C | 48 |
| H | 14,5 |
| L | 47 |
| i | 56HRC |
| kg | ~0,21 |

- PS1R48L34-105**
- 1x TF140573
- PS1F48L34-105**
- 1x TF140572
 - 1x _____
 - 1x PCSP60R
 - 1x PCSP60L
 - 1x PCS14
 - 1x PCGU2059
 - 1x M6X8ISO7380
 - 2x M5X14ISO4762
 - 2x PCD005
 - 1x M8X30ISO4762
 - 1x PCUSR14
 - 2x M5X10ISO4762
 - 1x PCKMR45M8
 - 2x D=6 DIN 5401
- kg ~1,0

p. 84, 85

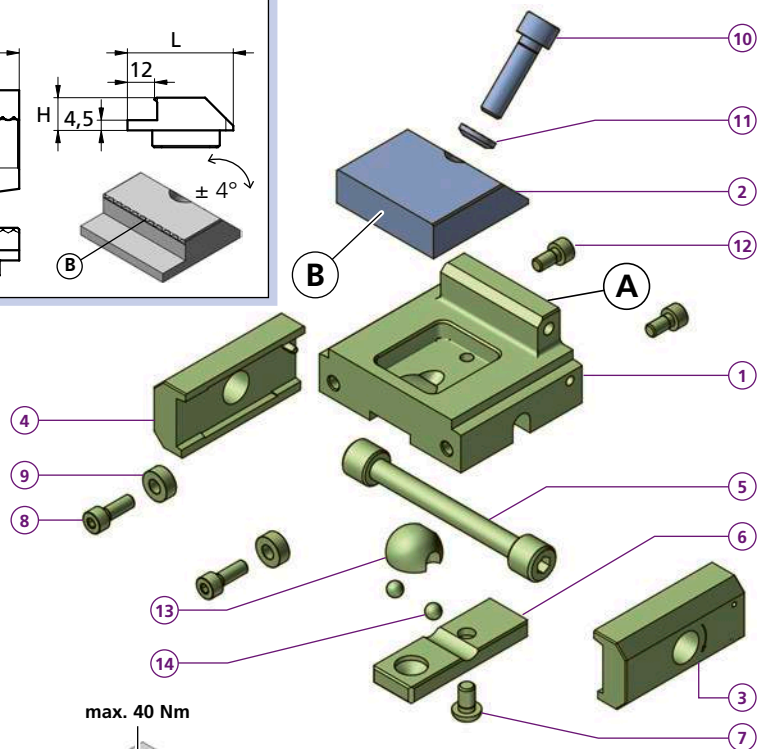
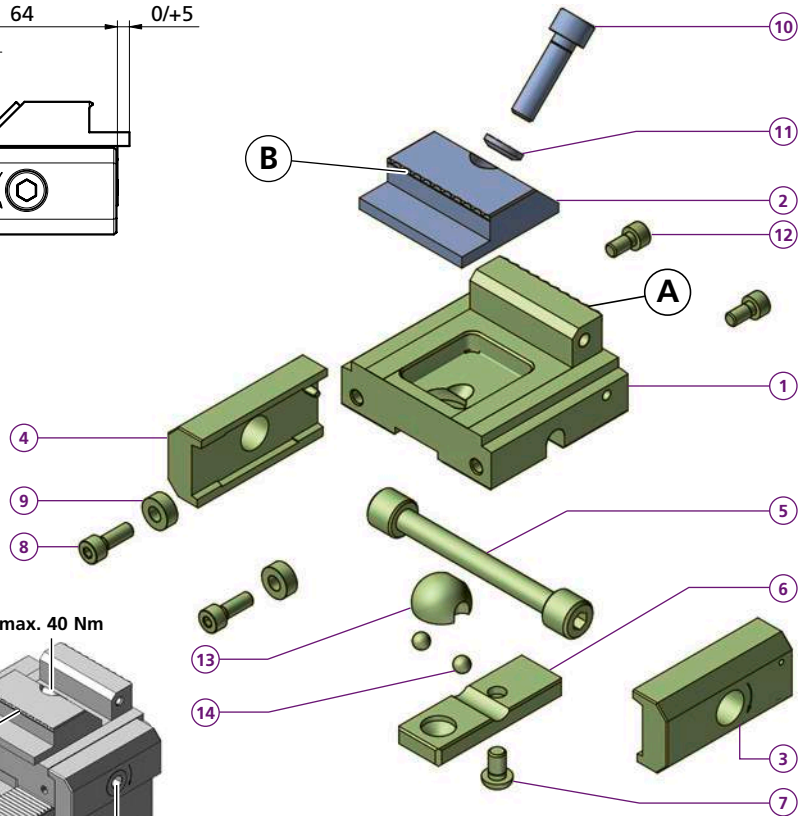
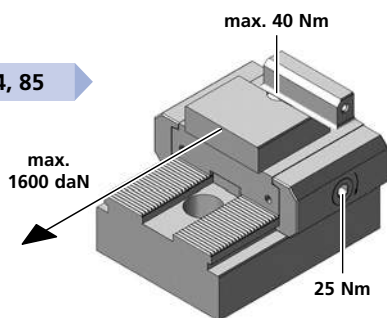

Bestellbeispiel / Ordering example:
 1x PS1R48L34-105 & 1x B123P

| Drehmoment Torque | | Spannkraft Workholding force | | |
|----------------------|---------|---------------------------------|-------|-----|
| Nm | (lb-ft) | ~daN | ~(lb) | ~t |
| 10 | 7,4 | = 400 | 880 | 0,4 |
| 20 | 14,8 | = 800 | 1'760 | 0,8 |
| 30 | 22,2 | = 1'200 | 2'650 | 1,2 |
| 40 | 29,6 | = 1'600 | 3'530 | 1,6 |

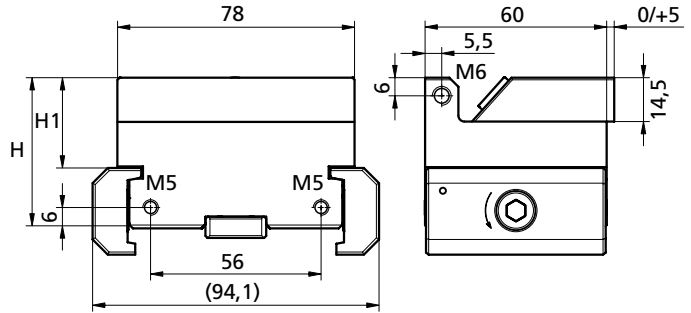
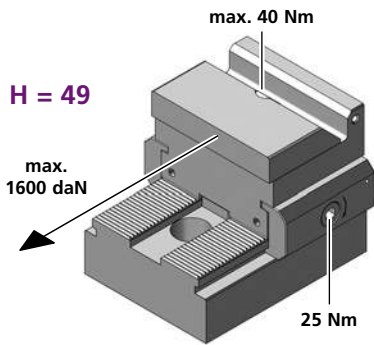
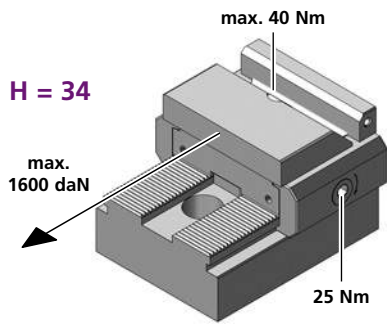

- PS1R78L34-105**
- 1** 1x TF140575
- PS1F78L34-105**
- 1** 1x TF140574
- 2** 1x
- 3** 1x PCSP60R
- 4** 1x PCSP60L
- 5** 1x PCS14
- 6** 1x PCGU2059
- 7** 1x M6X8ISO7380
- 8** 2x M5X14ISO4762
- 9** 2x PCD005
- 10** 1x M8X30ISO4762
- 11** 1x PCUSR14
- 12** 2x M5X10ISO4762
- 13** 1x PCKMR45M8
- 14** 2x D=6 DIN 5401
- H** = 34
- H1** = 15
- kg** ~1,0

p. 84, 85

- PS1R78L49-105**
- 1** 1x TK110399
- 15** 2x PCD20L15
- PS1F78L49-105**
- 1** 1x TK110400
- 15** 2x PCD20L15
- H** = 49
- H1** = 30
- kg** ~1,5

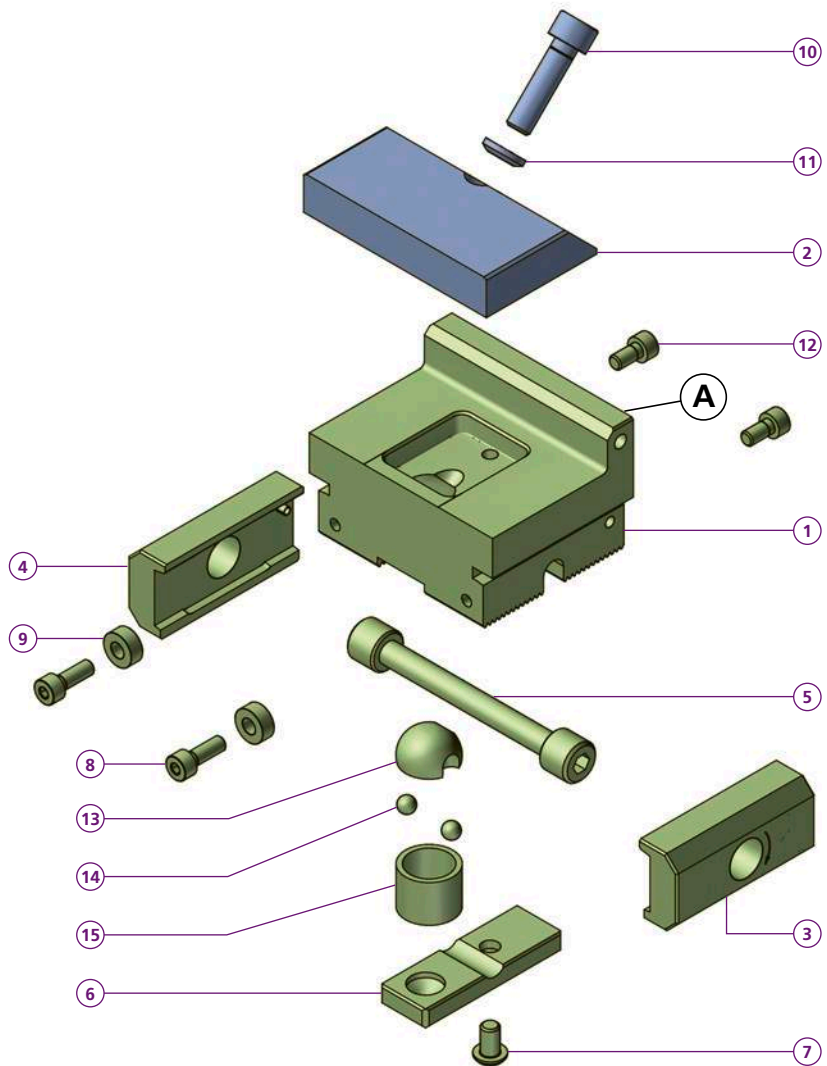

Bestellbeispiel / Ordering example:
1x PS1R48L34-105 & 1x B105

| Drehmoment Torque | Spannkraft Workholding force | | |
|----------------------|---------------------------------|-------|-----------|
| | Nm (lb-ft) | ~daN | ~(lb) ~t |
| 10 | 7,4 = | 400 | 880 0,4 |
| 20 | 14,8 = | 800 | 1'760 0,8 |
| 30 | 22,2 = | 1'200 | 2'650 1,2 |
| 40 | 29,6 = | 1'600 | 3'530 1,6 |

PS1PV94L34-105
PS1PV94L49-105

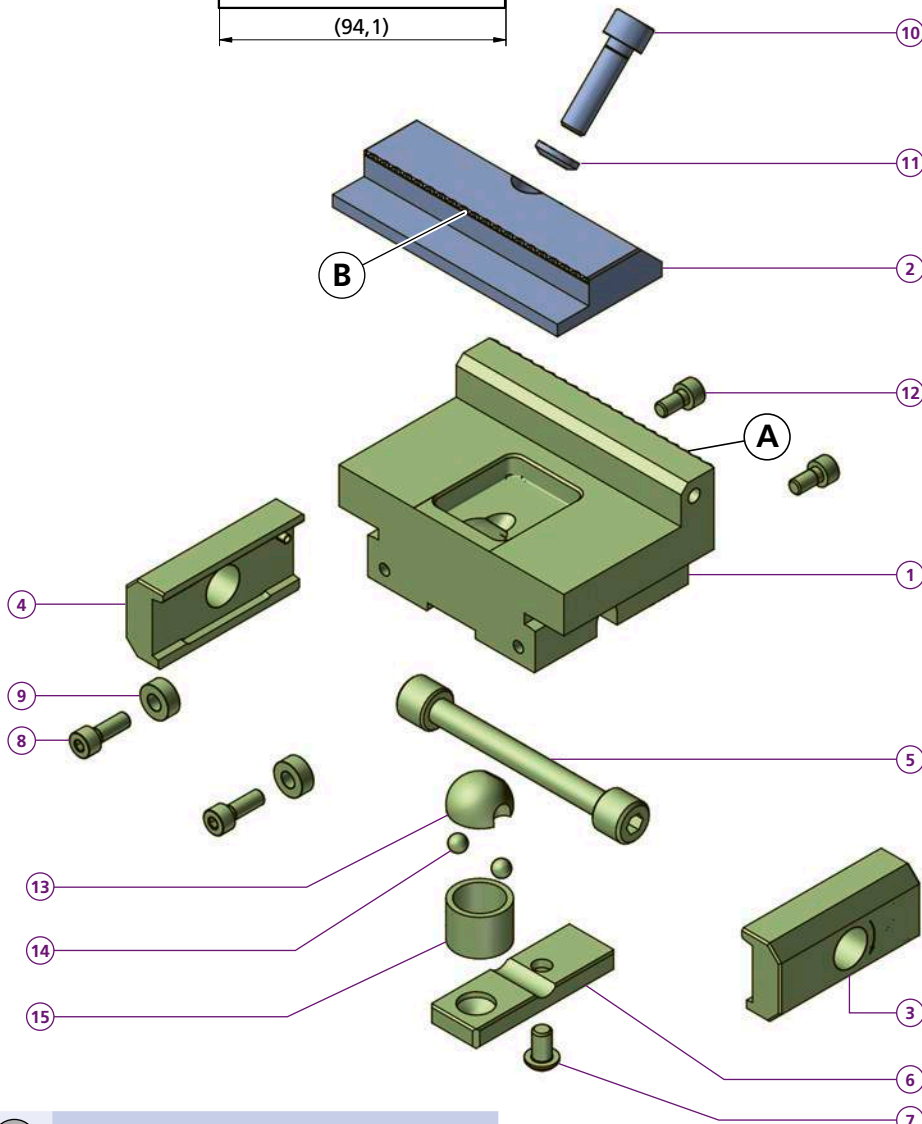
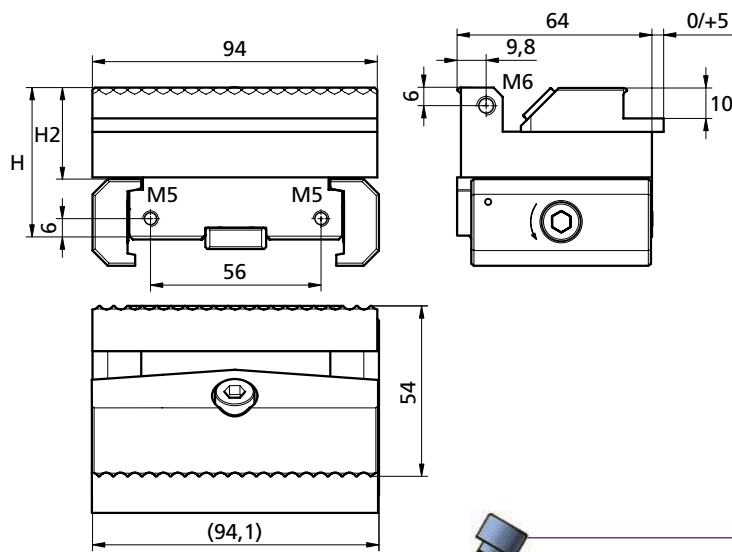
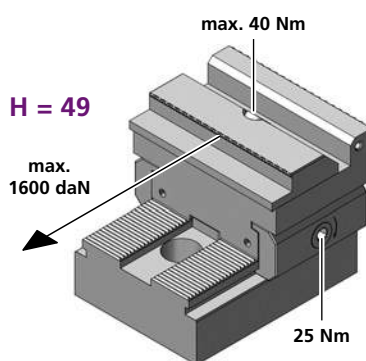
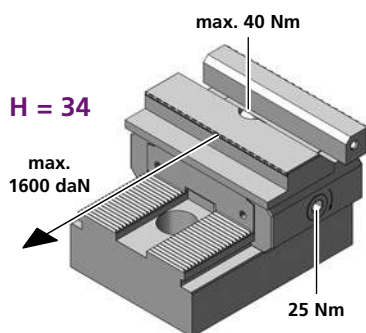

- PS1PV94L34-105**
- ① 1x TK120230
 - ② 1x _____
 - ③ 1x PCSP60R
 - ④ 1x PCSP60L
 - ⑤ 1x PCS14
 - ⑥ 1x PCGU2059
 - ⑦ 1x M6X8ISO7380
 - ⑧ 2x M5X14ISO4762
 - ⑨ 2x PCD005
 - ⑩ 1x M8X28ISO4762
 - ⑪ 1x PCUSR16
 - ⑫ 2x M5X10ISO4762
 - ⑬ 1x PCKMR45M8
 - ⑭ 2x D=6 DIN 5401
 - H = 34
 - H1 = 15
 - kg ~1,1

- PS1PV94L49-105**
- ① 1x TK110250
 - ⑮ 1x PCD20L15
 - H = 49
 - H1 = 30
 - kg ~1,8

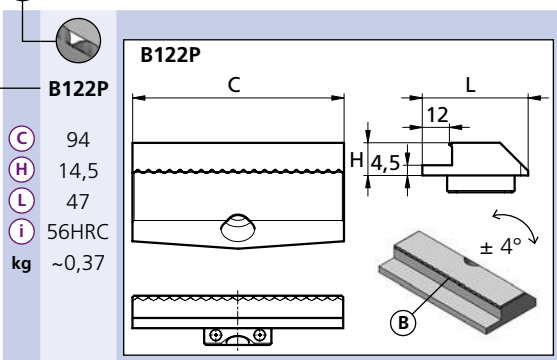

Bestellbeispiel / Ordering example:
1x PS1PV94L49-105 & 1x B122P

| Nm | Drehmoment Torque | | Spannkraft Workholding force | | |
|----|----------------------|---|---------------------------------|-------|-----|
| | (lb-ft) | = | ~daN | ~(lb) | ~t |
| 10 | 7,4 | = | 400 | 880 | 0,4 |
| 20 | 14,8 | = | 800 | 1'760 | 0,8 |
| 30 | 22,2 | = | 1'200 | 2'650 | 1,2 |
| 40 | 29,6 | = | 1'600 | 3'530 | 1,6 |

Separat bestellen / Order separately

**PS1R/F48L49-105
PS5X48L49-105**

**Linear 5axes
powerCLAMP**

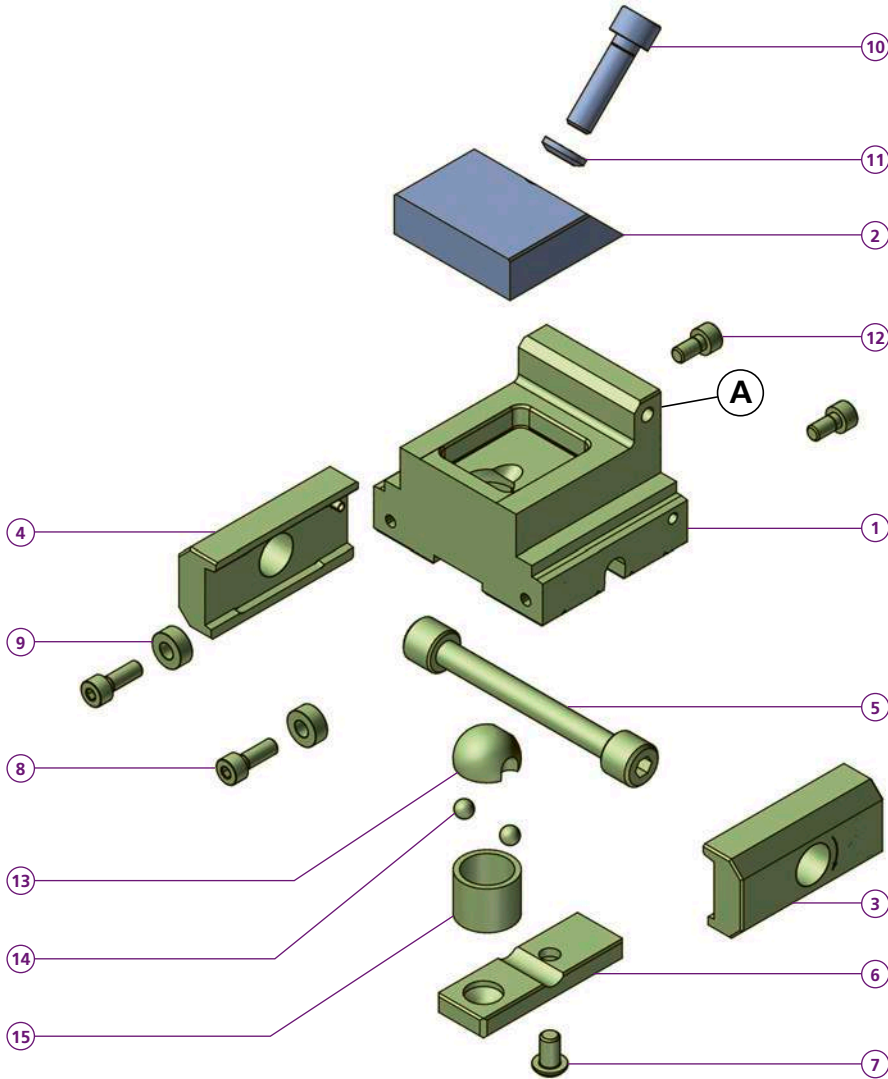
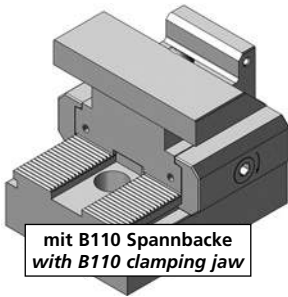
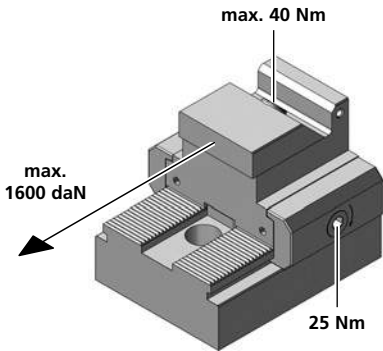
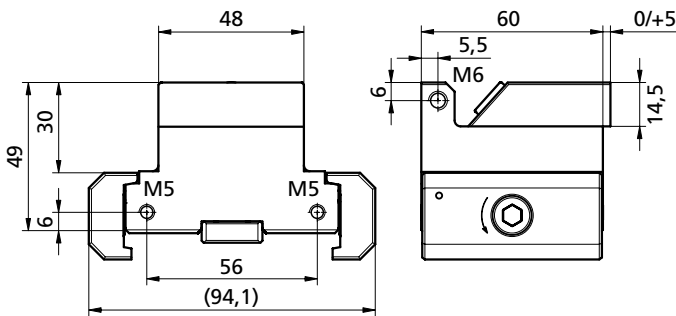
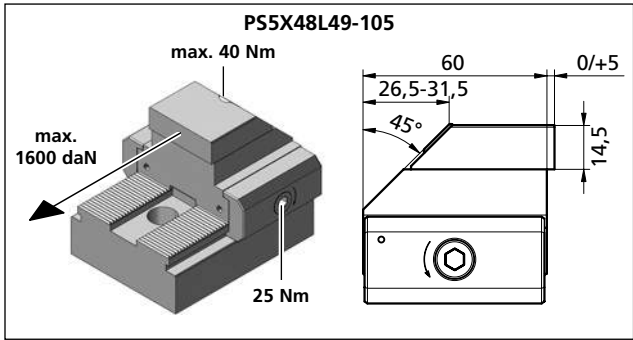

| | |
|----|----------------------|
| | PS5X48L49-105 |
| ① | 1x TF190651 |
| ⑨ | 2x PCD005 |
| ⑧ | 2x M5X14ISO4762 |
| kg | ~1,2 |
| | PS1F48L49-105 |
| ① | 1x TF140673 |
| | PS1R48L49-105 |
| ① | 1x TF140672 |
| ② | 1x — |
| ③ | 1x PCSP60R |
| ④ | 1x PCSP60L |
| ⑤ | 1x PCS14 |
| ⑥ | 1x PCGU2059 |
| ⑦ | 1x M6X8ISO7380 |
| ⑧ | 2x M5X14ISO4762 |
| ⑨ | 2x PCD005 |
| ⑩ | 1x M8X30ISO4762 |
| ⑪ | 1x PCUSR14 |
| ⑫ | 2x M5X10ISO4762 |
| ⑬ | 1x PCKMR45M8 |
| ⑭ | 2x D=6 DIN 5401 |
| ⑮ | 1x PCD20L15 |
| kg | ~1,3 |

p. 84, 85



Bestellbeispiel / Ordering example:
1x PS1F48L49-105 & 1x B105

| Drehmoment Torque | Spannkraft Workholding force | | |
|----------------------|---------------------------------|-------|----------|
| | Nm (lb-ft) | ~daN | ~(lb) ~t |
| 10 | 7,4 = 400 | 880 | 0,4 |
| 20 | 14,8 = 800 | 1'760 | 0,8 |
| 30 | 22,2 = 1'200 | 2'650 | 1,2 |
| 40 | 29,6 = 1'600 | 3'530 | 1,6 |

Separat bestellen / Order separately

PS5X48L34-105

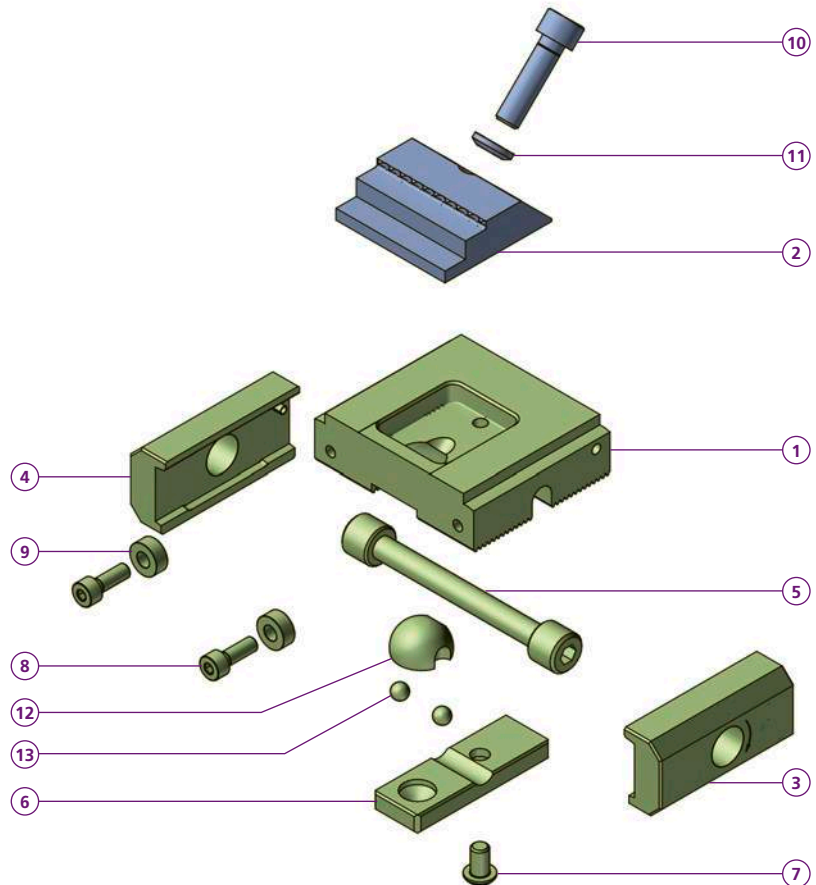
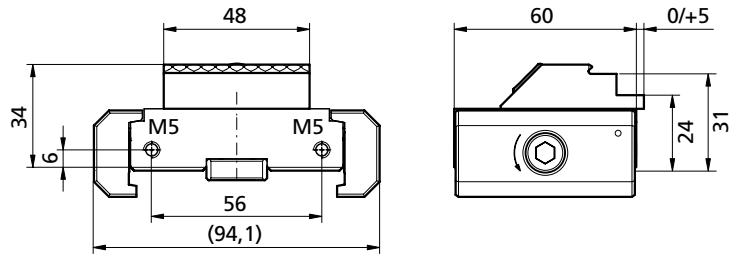
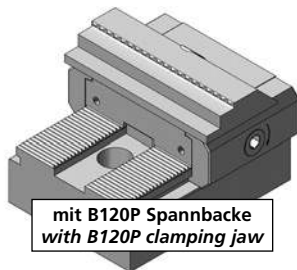
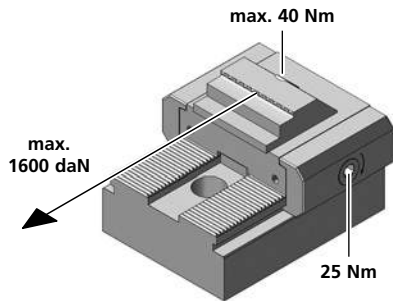

PS5X48L34-105

- ① 1x T00365
- ② 1x —————
- ③ 1x PCSP60R
- ④ 1x PCSP60L
- ⑤ 1x PCS14
- ⑥ 1x PCGU2059
- ⑦ 1x M6X8ISO7380
- ⑧ 2x M5X14ISO4762
- ⑨ 2x PCD005
- ⑩ 1x M8X28ISO4762
- ⑪ 1x PCUSR16
- ⑫ 1x PCKMR45M8
- ⑬ 2x D=6 DIN 5401

p. 84, 85

kg ~0,9

Bestellbeispiel / Ordering example:
1x PS5X48L34-105 & 1x B105

| Drehmoment Torque | | Spannkraft Workholding force | | |
|----------------------|---------|---------------------------------|-------|-----|
| Nm | (lb-ft) | ~daN | ~(lb) | ~t |
| 10 | 7,4 | = 400 | 880 | 0,4 |
| 20 | 14,8 | = 800 | 1'760 | 0,8 |
| 30 | 22,2 | = 1'200 | 2'650 | 1,2 |
| 40 | 29,6 | = 1'600 | 3'530 | 1,6 |

Separat bestellen / Order separately

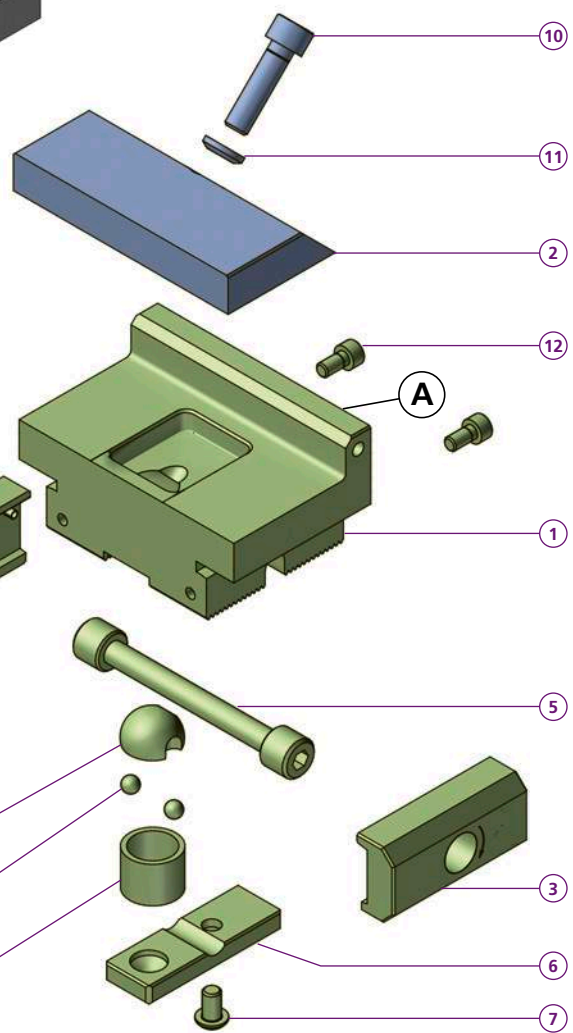
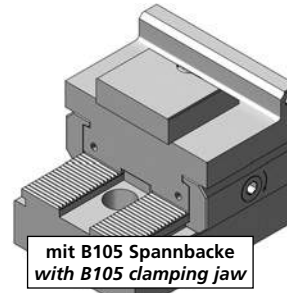
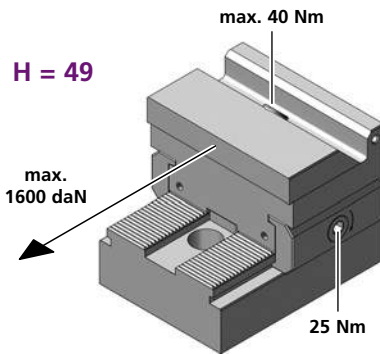
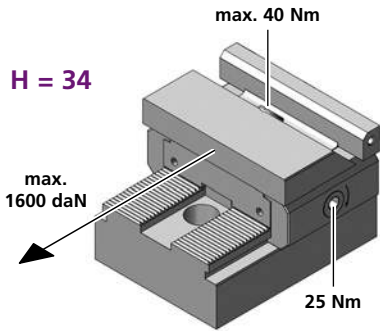
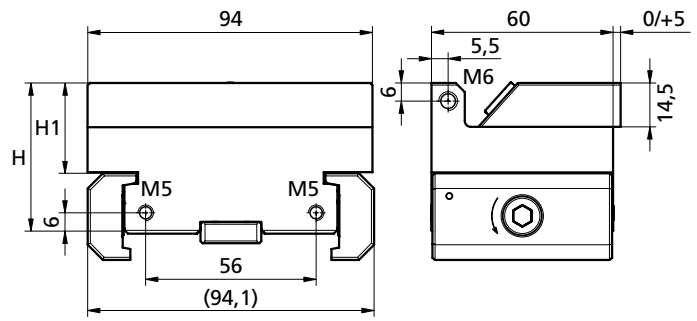
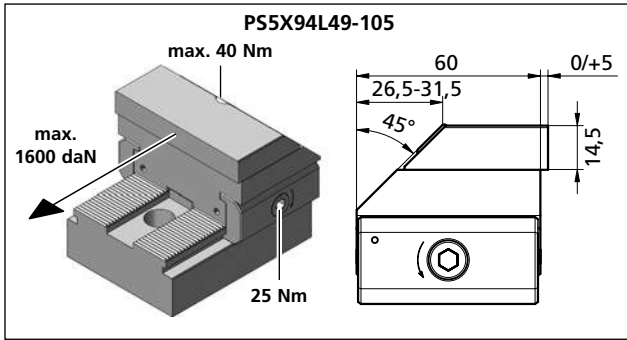

- PS5X94L49-105**
- 1x TW100186
 - 2x PCD20L15
 - 2x PCD005
 - 2x M5X14ISO4762
 - kg ~1,5
- PS1F94L34-105**
- 1x TH130785
- PS1R94L34-105**
- 1x TH130786
 - 1x — p. 84, 85
 - 1x PCSP60R
 - 1x PCSP60L
 - 1x PCS14
 - 1x PCGU2059
 - 1x M6X8ISO7380
 - 2x M5X14ISO4762
 - 2x PCD005
 - 1x M8X30ISO4762
 - 1x PCUSR14
 - 2x M5X10ISO4762
 - 1x PCKMR45M8
 - 2x D=6 DIN 5401
 - H = 34
 - H1 = 15
 - kg ~1,0

- PS1F94L49-105**
- 1x TF140674
 - 2x PCD20L15
- PS1R94L49-105**
- 1x TF140675
 - 2x PCD20L15
 - H = 49
 - H1 = 30
 - kg ~1,7

Bestellbeispiel / Ordering example:
1x PS1R94L49-105 & 1x B105

| Nm | Drehmoment Torque | | Spannkraft Workholding force | | |
|----|----------------------|---|---------------------------------|-------|-----|
| | (lb-ft) | | ~daN | ~(lb) | ~t |
| 10 | 7,4 | = | 400 | 880 | 0,4 |
| 20 | 14,8 | = | 800 | 1'760 | 0,8 |
| 30 | 22,2 | = | 1'200 | 2'650 | 1,2 |
| 40 | 29,6 | = | 1'600 | 3'530 | 1,6 |

Separat bestellen / Order separately

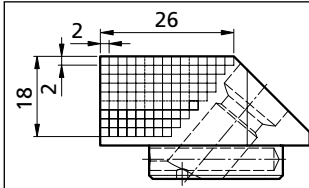

Zum Erstellen Ihrer individuellen Formbacke: *If a dedicated jaw is being machined:*
 Schnittzeichnung zum Ermitteln der maximalen Bearbeitungsprofiltiefe
Sectional drawing to determine the maximum machining depth

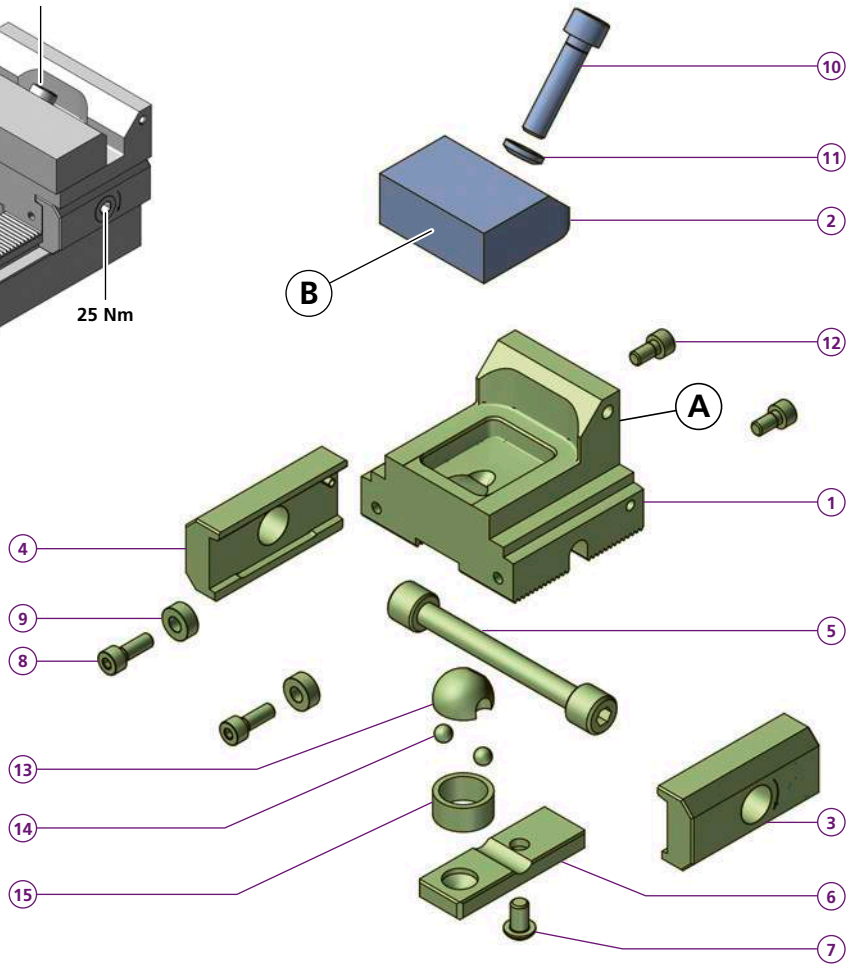
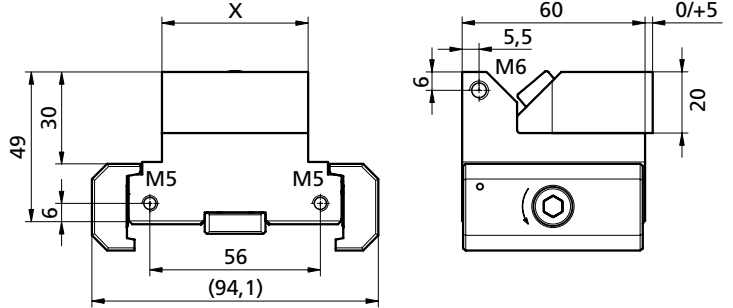
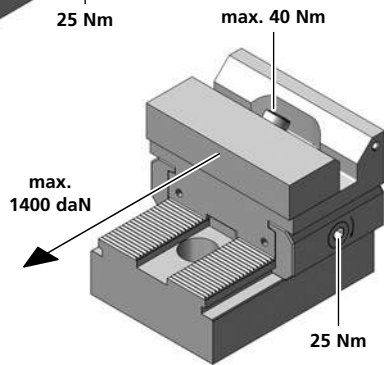
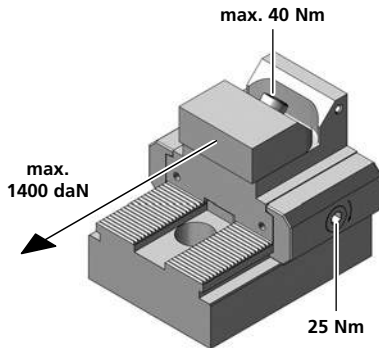

| | |
|-------------------------|-----------------|
| PS1R48L49-105H20 | |
| 1 | 1x TW100161-01 |
| 2 | 1x |
| 3 | 1x PCSP60R |
| 4 | 1x PCSP60L |
| 5 | 1x PCS14 |
| 6 | 1x PCGU2059 |
| 7 | 1x M6X8ISO7380 |
| 8 | 2x M5X14ISO4762 |
| 9 | 2x PCD005 |
| 10 | 1x M8X35ISO4762 |
| 11 | 1x PCUSR14 |
| 12 | 2x M5X10ISO4762 |
| 13 | 1x PCKMR45M8 |
| 14 | 2x D=6 DIN 5401 |
| 15 | 1x PCD20L095 |
| X | = 48 |
| kg | ~1,2 |
| PS1R94L49-105H20 | |
| 1 | 1x TW100161-07 |
| X | = 94 |
| kg | ~1,5 |

Bestellbeispiel / Ordering example: 1x PS1R48L49-105H20 & 1x B107H20

| | B105H20 | B106H20 | B107H20 | B110H20 | B111H20 | B112H20 |
|----|-----------------|-----------------|---------|-----------------|-----------------|---------|
| C | 48 | 48 | 48 | 94 | 94 | 94 |
| H | 20 | 20 | 20 | 20 | 20 | 20 |
| L | 47 | 47 | 47 | 47 | 47 | 47 |
| i | HV700 x0,2mm | HV700 x0,2mm | * | HV700 x0,2mm | HV700 x0,2mm | * |
| kg | ~0,38 | ~0,38 | ~0,38 | ~0,57 | ~0,56 | ~0,56 |

B105H20, B106H20, B107H20

B110H20, B111H20, B112H20

Separat bestellen / Order separately

PS1R125L49-105H20

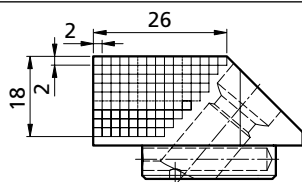

Zum Erstellen Ihrer individuellen Formbacke: *If a dedicated jaw is being machined:*
 Schnittzeichnung zum Ermitteln der maximalen Bearbeitungsprofiltiefe
 Sectional drawing to determine the maximum machining depth

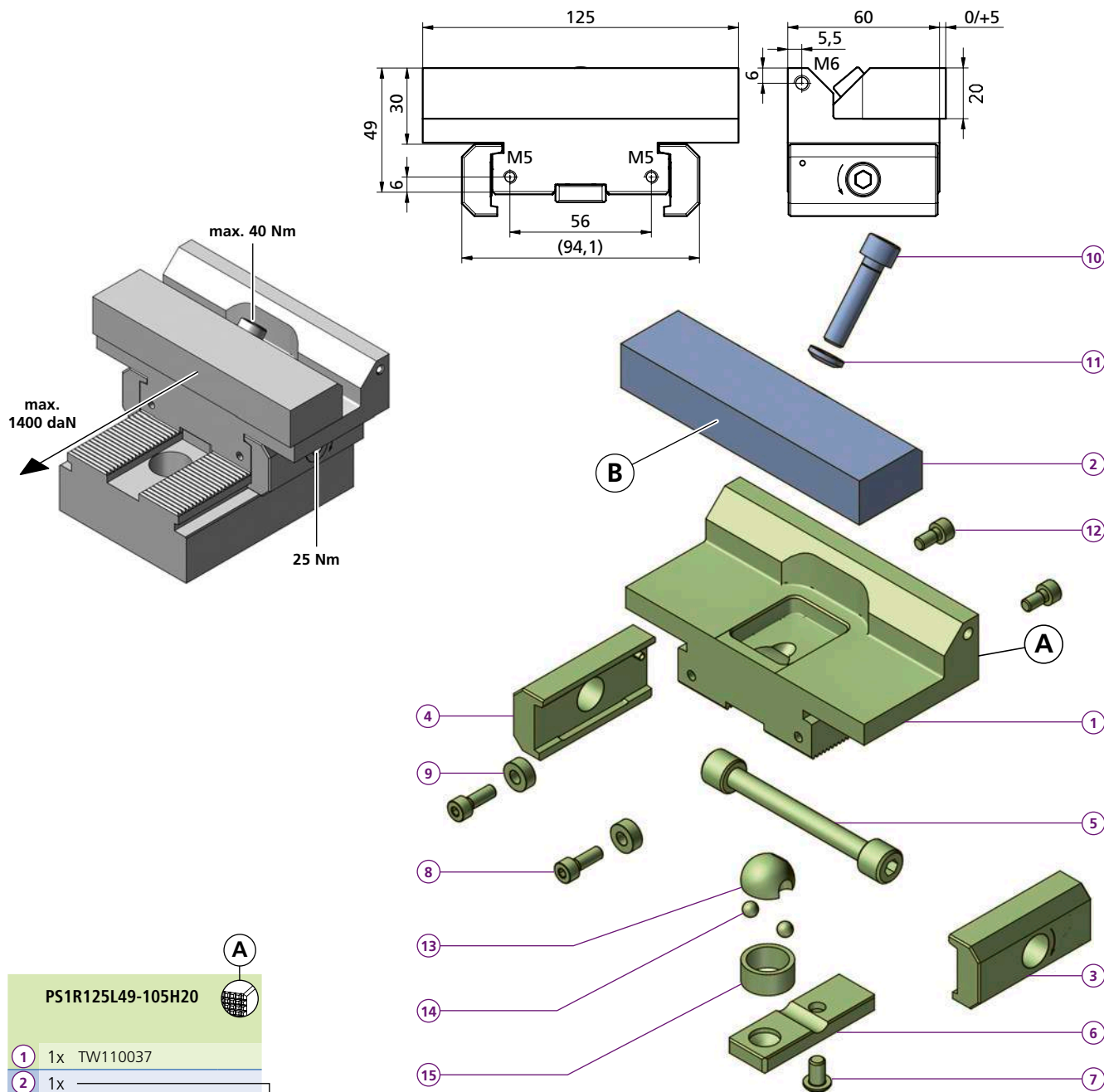

| PS1R125L49-105H20 | |
|-------------------|-----------------|
| 1 | 1x TW110037 |
| 2 | 1x |
| 3 | 1x PCSP60R |
| 4 | 1x PCSP60L |
| 5 | 1x PCS14 |
| 6 | 1x PCGU2059 |
| 7 | 1x M6X8ISO7380 |
| 8 | 2x M5X14ISO4762 |
| 9 | 2x PCD005 |
| 10 | 1x M8X35ISO4762 |
| 11 | 1x PCUSR14 |
| 12 | 2x M5X10ISO4762 |
| 13 | 1x PCKMR45M8 |
| 14 | 2x D=6 DIN 5401 |
| 15 | 1x PCD20L095 |
| kg | ~1,7 |

Bestellbeispiel / Ordering example: 1x PS1R125L49-105H20 & 1x B132H20P

| | B130H20P | B131H20P | B132H20P |
|----|----------|----------|----------|
| C | 125 | 125 | 125 |
| H | 20 | 20 | 20 |
| L | 47 | 47 | 47 |
| i | HV700 | HV700 | * |
| | x0,2mm | x0,2mm | |
| kg | ~0,71 | ~0,71 | ~0,71 |

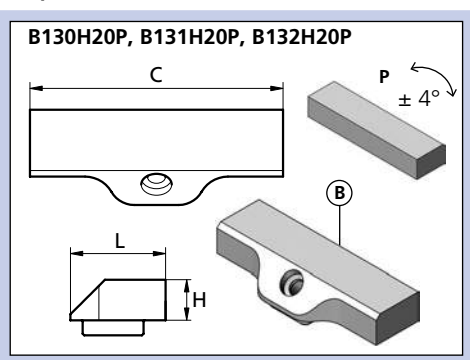

* = weicher Stahl / soft steel

Separat bestellen / Order separately

Linear- Spannbacken ... Linear clamping jaws ...



powerCLAMP

zum Einsatz in unterschiedlichen Spannsituationen
for use in different clamping situations

| Art. Nr. | | | | kg |
|--------------|---------------|---------------|--|-------|
| B110 | HV700 x 0,2mm | | | ~0,49 |
| B110P | HV700 x 0,2mm | $\pm 4^\circ$ | | ~0,49 |



mit Prägeinsätzen
with direct-stamping inserts

| Art. Nr. | | | kg |
|--------------------|---------------|--|-------|
| B110P-PRGM8 | HV700 x 0,2mm | | ~0,46 |

| Art. Nr. | | | kg |
|--------------|---------------|---------------|-------|
| B111 | HV700 x 0,2mm | | ~0,48 |
| B111P | HV700 x 0,2mm | $\pm 4^\circ$ | ~0,48 |

| | | | |
|---------------|---|---------------|-------|
| B112 | weicher Stahl soft steel (1.2312) | | ~0,49 |
| B112P | weicher Stahl soft steel (1.2312) | $\pm 4^\circ$ | ~0,49 |
| B112HG | Hochgenau High-precision | | ~0,49 |
| B112E | Einsatzstahl (1.5752) Case hardening steel | | ~0,49 |
| B112EP | Einsatzstahl (1.5752) Case hardening steel | $\pm 4^\circ$ | ~0,47 |

| | | | |
|--------------|---------------|---------------|-------|
| B113 | HV700 x 0,2mm | | ~0,39 |
| B113P | HV700 x 0,2mm | $\pm 4^\circ$ | ~0,39 |

| | | | |
|--------------|-------|---------------|-------|
| B117P | 57HRC | $\pm 4^\circ$ | ~0,46 |
|--------------|-------|---------------|-------|

| | | | |
|-------------|-------|--|------|
| B120 | 57HRC | | ~0,4 |
|-------------|-------|--|------|

| | | | |
|--------------|-------|---------------|------|
| B120P | 57HRC | $\pm 4^\circ$ | ~0,4 |
|--------------|-------|---------------|------|

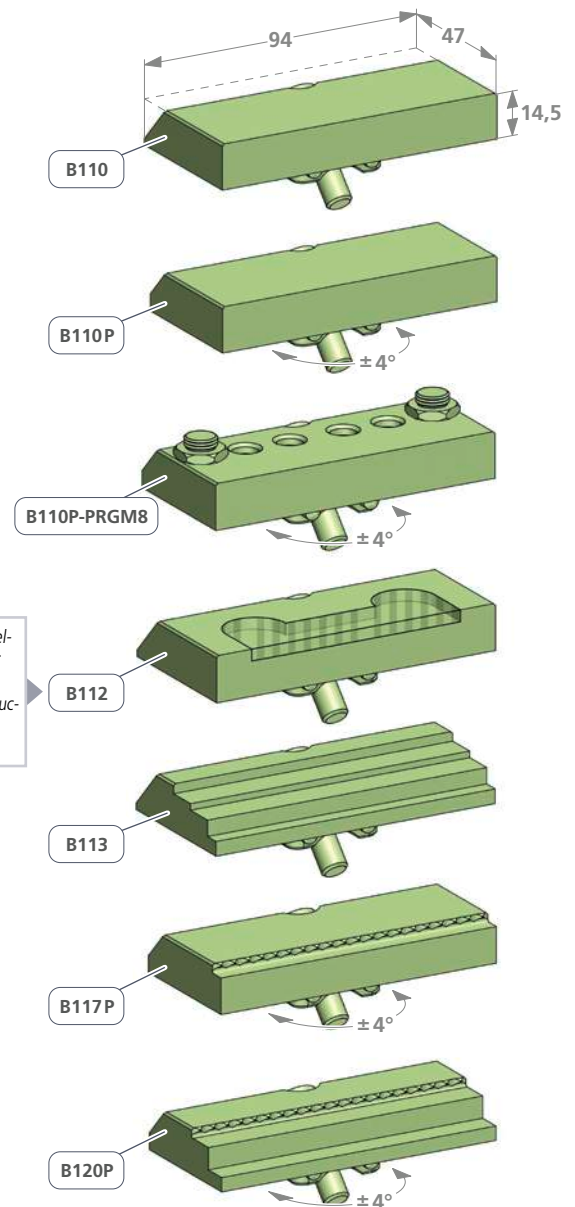

Weich, zur Herstellung individueller Formbacke.
Soft, for the production of individual moulding jaw.

Modulhöhen / Module heights 34 / 49 mm

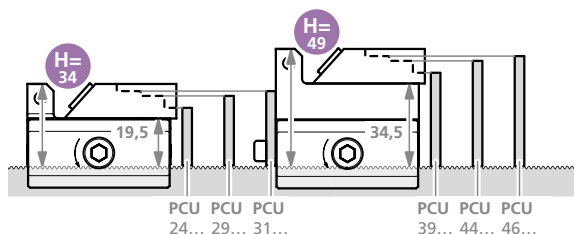

Beim Einsatz einer Stufenbacke, ist die richtige Modulspannhöhe 34 mm / 49 mm zu berücksichtigen. Die Werkstücke auf der Anschlagseite werden mit den passenden Parallelunterlagen abgestützt.

When using a step jaw is applied, the correct module clamping height 34 mm / 49 mm must be taken into account. The workpieces on the end module are supported with the appropriate steel parallel.

Eingesetzte Stufenbacken / Inserted stepped jaws (B113)

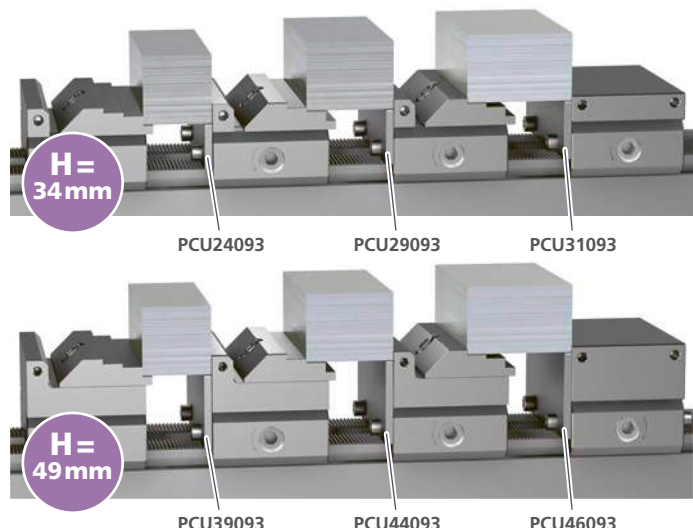

Linear- Spannbacken ... Linear clamping jaws ...

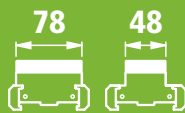

powerCLAMP

zum Einsatz in unterschiedlichen Spannsituationen
for use in different clamping situations

| Art.Nr. | | | | kg |
|----------------|--------------------------------------|---------------|--|-------|
| B140 | HV700 x 0,2mm | | | ~0,41 |
| B140P | HV700 x 0,2mm | $\pm 4^\circ$ | | ~0,41 |
| B141 | HV700 x 0,2mm | | | ~0,41 |
| B141P | HV700 x 0,2mm | $\pm 4^\circ$ | | ~0,41 |
| B105 | HV700 x 0,2mm | | | ~0,27 |
| B105P | HV700 x 0,2mm | $\pm 4^\circ$ | | ~0,27 |
| B105-15 | HV700 x 0,2mm | | | ~0,27 |
| B106 | HV700 x 0,2mm | | | ~0,27 |
| B106P | HV700 x 0,2mm | $\pm 4^\circ$ | | ~0,27 |
| B107 | weicher Stahl soft steel (1.2312) | | | ~0,27 |
| B107P | weicher Stahl soft steel (1.2312) | $\pm 4^\circ$ | | ~0,27 |
| B108 | HV700 x 0,2mm | | | ~0,22 |
| B108P | HV700 x 0,2mm | $\pm 4^\circ$ | | ~0,22 |
| B115 | 57HRC | | | ~0,21 |
| B115P | 57HRC | $\pm 4^\circ$ | | ~0,21 |
| B116P | 57HRC | $\pm 4^\circ$ | | ~0,25 |

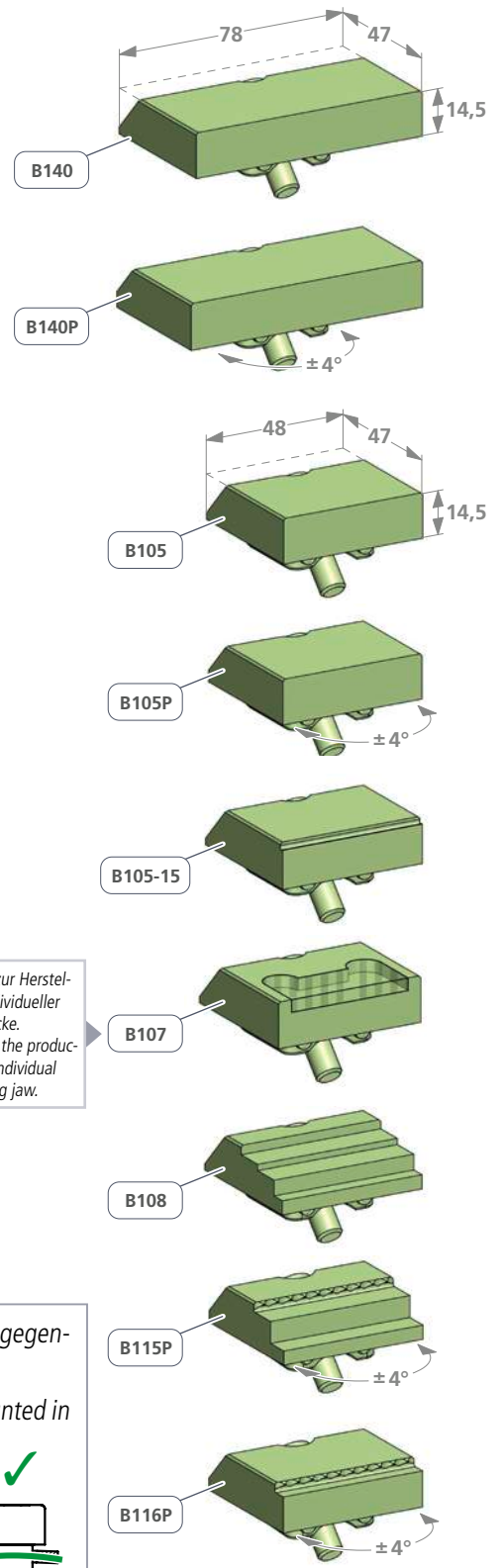

Für Prägebacken / For stamping jaws

PF-SET Kräftehaltung mit Nachfederung
Spring loaded mechanism to maintain clamping force

Bei allen Prägebacken kann die Kräftehaltung mit den nachfedernden Tellerfedern eingesetzt werden um ein Freiwigeln des Werkstücks zu verhindern.

On every spring loaded stamping jaw, the force retention with the disc springs can be used to prevent the workpiece from wiggling free.



Die Tellerfedern werden gegenläufig montiert.

The disc springs are mounted in opposite directions.

Detailvermessung der Stufenbacken / Detailed dimensioning of the stepped jaws

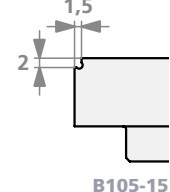
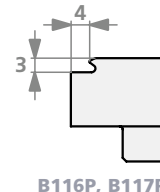
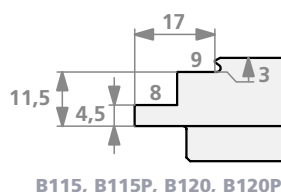
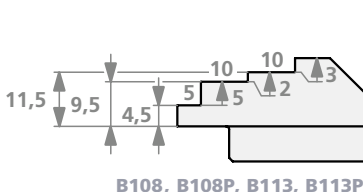

Anschlagmodule ... End module ...

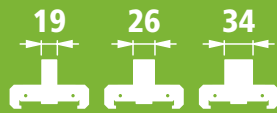

5axes powerCLAMP

für die horizontale und vertikale Bearbeitung
for horizontal and vertical machining

| Art. Nr. | kg | X |
|------------------|------|----|
| PAND19-49 | ~1,2 | 19 |
| PAND26-49 | ~2,2 | 26 |
| PAND34-49 | ~2,3 | 34 |

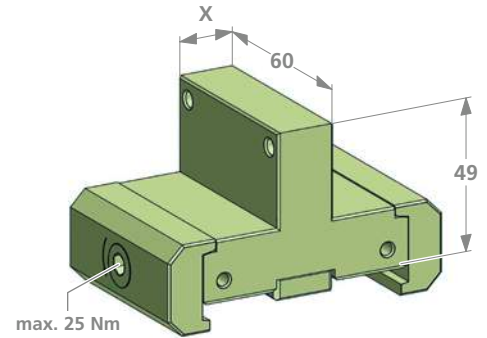

Schmale Anschlagmodule und Werkstücke
in der Mehrfachspannung.

Slim stop modules and workpieces in
multiple clamping.

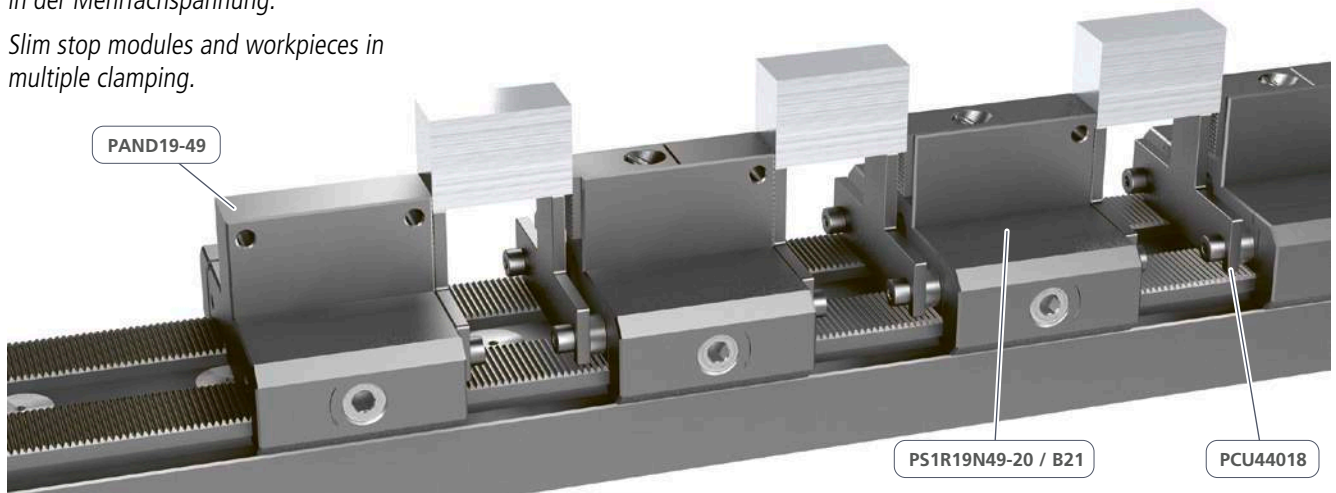

für 5-Achs Bearbeitung
for 5-axis machining

| Art. Nr. | kg | X |
|-------------------|------|----|
| PA5X19-49F | ~1,1 | 19 |
| PA5X19-49R | ~1,1 | 19 |
| PA5X26-49F | ~1,2 | 26 |
| PA5X26-49R | ~1,2 | 26 |
| PA5X34-49F | ~1,2 | 34 |
| PA5X34-49R | ~1,2 | 34 |

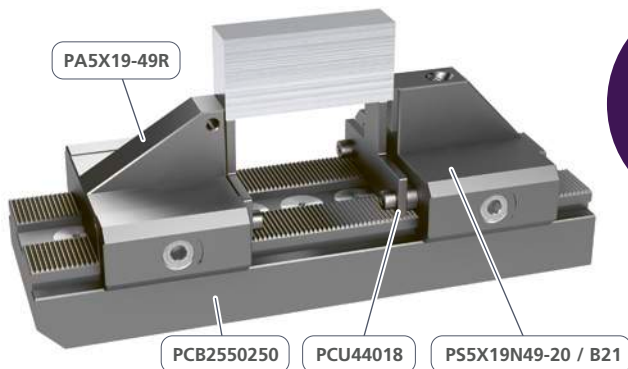
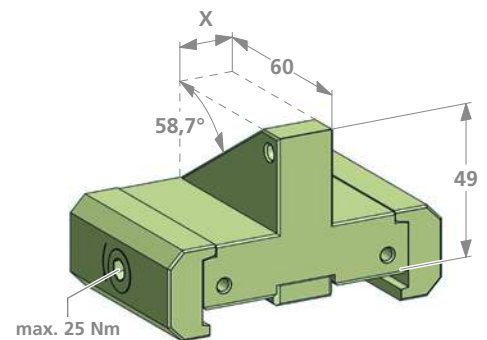

Module
einsetzbar auf
Zentrischspannern
oder Basisschienen.
Modules
can be used on self
centrig vises or
base rails.



Anschlagmodule ...
End module ...

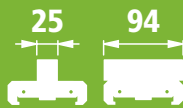

powerCLAMP

für die horizontale und vertikale Bearbeitung
for horizontal and vertical machining

| Art. Nr. | kg |
|------------------|------|
| PAND25-44 | ~1,1 |

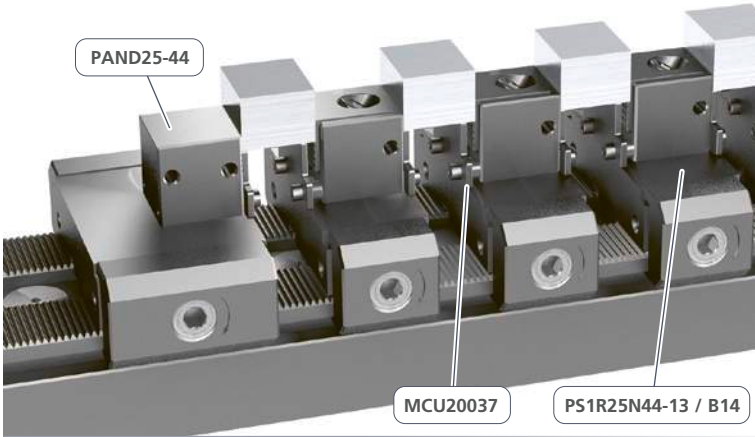
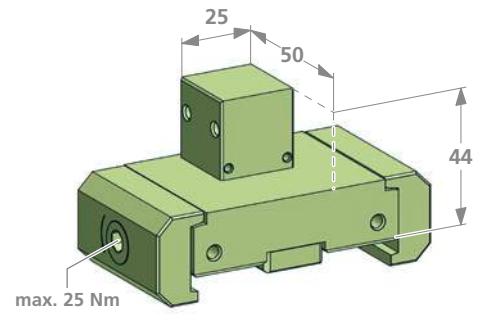

Schlankes und kurzes Anschlagmodul für Kleinteil-Serien (Mehrfachspannung).

Slim and short end module for small part series (Multiple workholding).

| Art. Nr. | kg |
|------------------|------|
| PAND94-44 | ~1,3 |

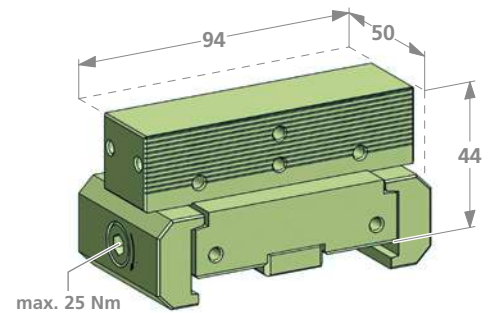

Die Anschlagfläche enthält 2 Passbohrungen. Mit MS50 Passschrauben kann mittig ein Seitenanschlag präzise platziert werden.

The stop surface contains 2 fitting holes. A side stop can be placed precisely in the centre with MS50 fitting screws.

Anschlagmodul mit Doppelspannfunktion. Verdoppelt die Anzahl Spannbereiche auf gleichbleibendem Raum.

End module with double clamping function. Doubles the number of clamping areas in the same amount of working space.

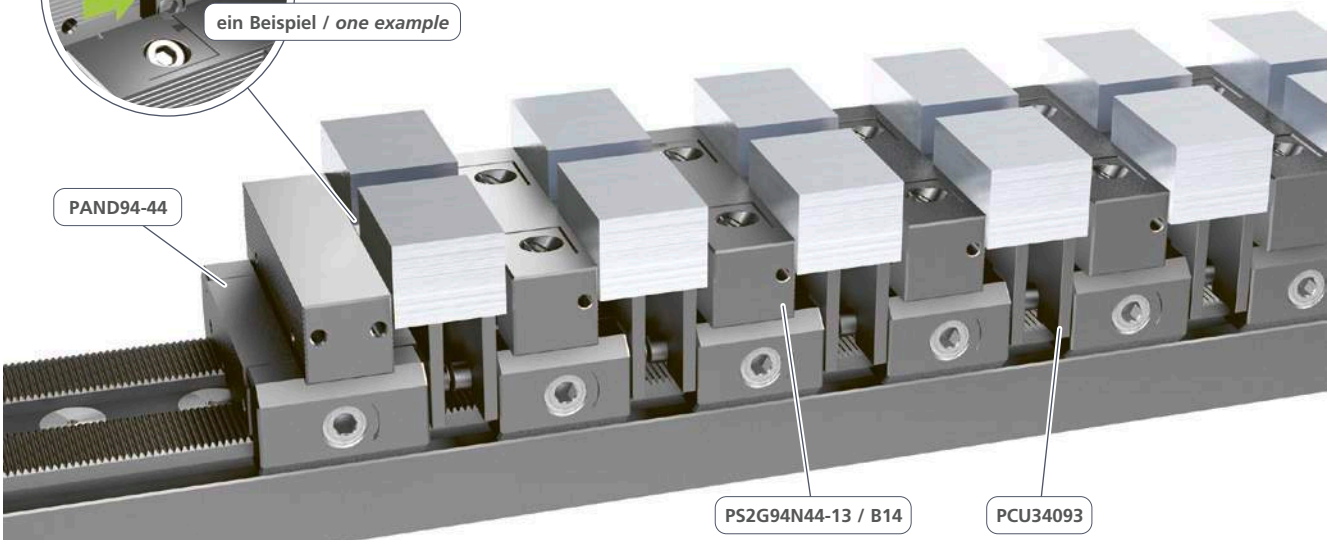

Anschlagmodule ...
End module ...

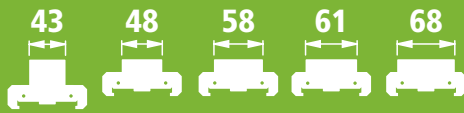

5axes
powerCLAMP

für die horizontale und vertikale Bearbeitung
for horizontal and vertical machining

| Art. Nr. | | kg | X | H |
|-----------|--|------|----|----|
| PAND43-49 | | ~1,6 | 43 | 49 |
| PAND48-34 | | ~1,3 | 48 | 34 |
| PAND48-49 | | ~1,6 | 48 | 49 |
| PAND48-75 | | ~2,2 | 48 | 75 |
| PAND58-34 | | ~1,4 | 58 | 34 |
| PAND58-49 | | ~1,8 | 58 | 49 |
| PAND61-34 | | ~1,4 | 61 | 34 |
| PAND68-34 | | ~2,3 | 68 | 34 |

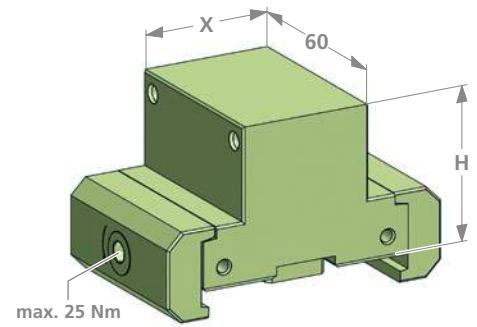

43 mm bis 68 mm breite Anschlagmodule für die Einzel- und Mehrfachspannung.
43 mm to 68 mm wide end modules for single and multiple clamping.

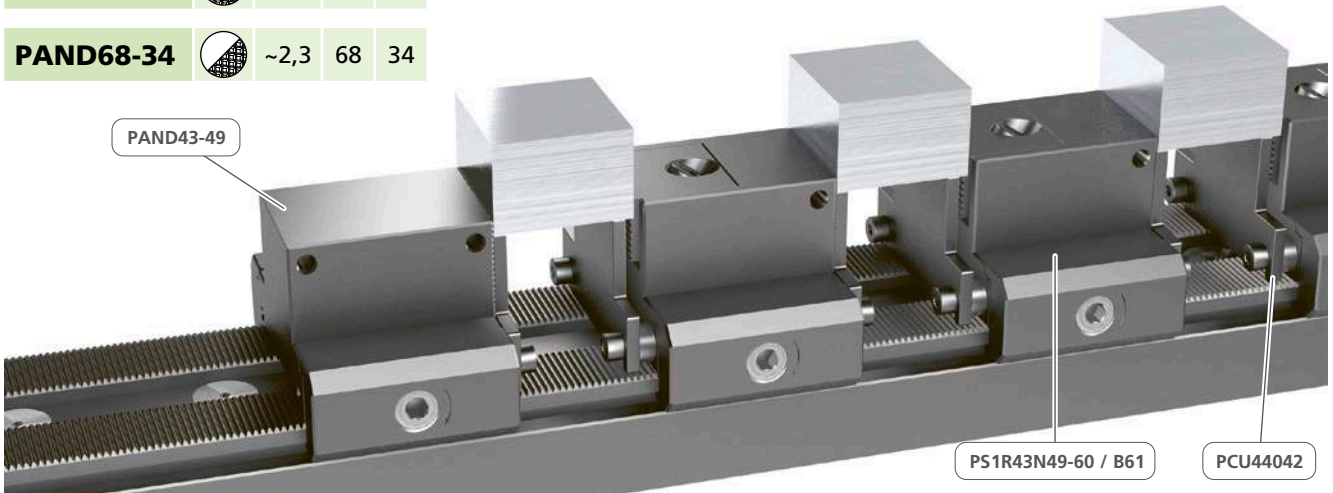

für 5-Achs Bearbeitung
for 5-axis machining

| Art. Nr. | | kg | X |
|------------|--|------|----|
| PA5X43-49F | | ~1,3 | 43 |
| PA5X43-49R | | ~1,3 | 43 |
| PA5X48-49F | | ~1,4 | 48 |
| PA5X48-49R | | ~1,4 | 48 |



Module einsetzbar auf Zentrischspannern oder Basisschienen.
Modules can be used on self centrig vises or base rails.

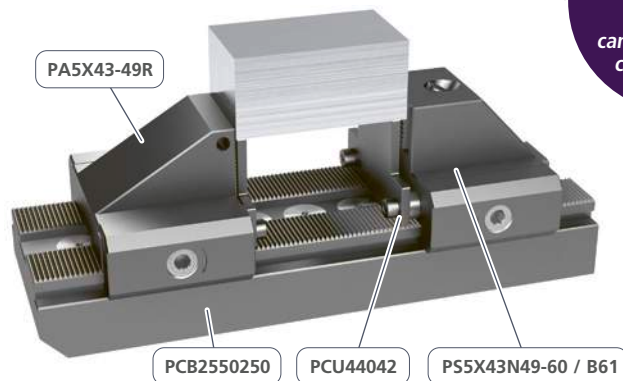
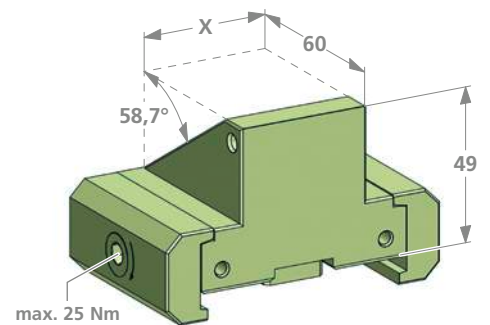

Anschlagmodule ... End module ...

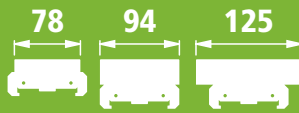

5axes powerCLAMP

für die horizontale und vertikale Bearbeitung
for horizontal and vertical machining

| Art. Nr. | kg | X | H |
|-------------------|------|-----|----|
| PAND78-34 | ~1,5 | 78 | 34 |
| PAND78-49 | ~2,1 | 78 | 49 |
| PAND94-34 | ~2,3 | 94 | 34 |
| PAND94-49 | ~2,7 | 94 | 49 |
| PAND125-49 | ~2,7 | 125 | 49 |

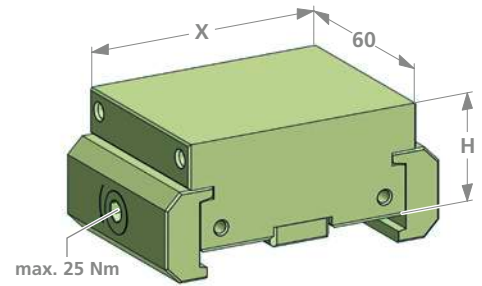

78 mm bis 125 mm breite Anschlagmodule
für die Einzel- und Mehrfachspannung.

78 mm to 125 mm wide end modules for
single and multiple clamping.

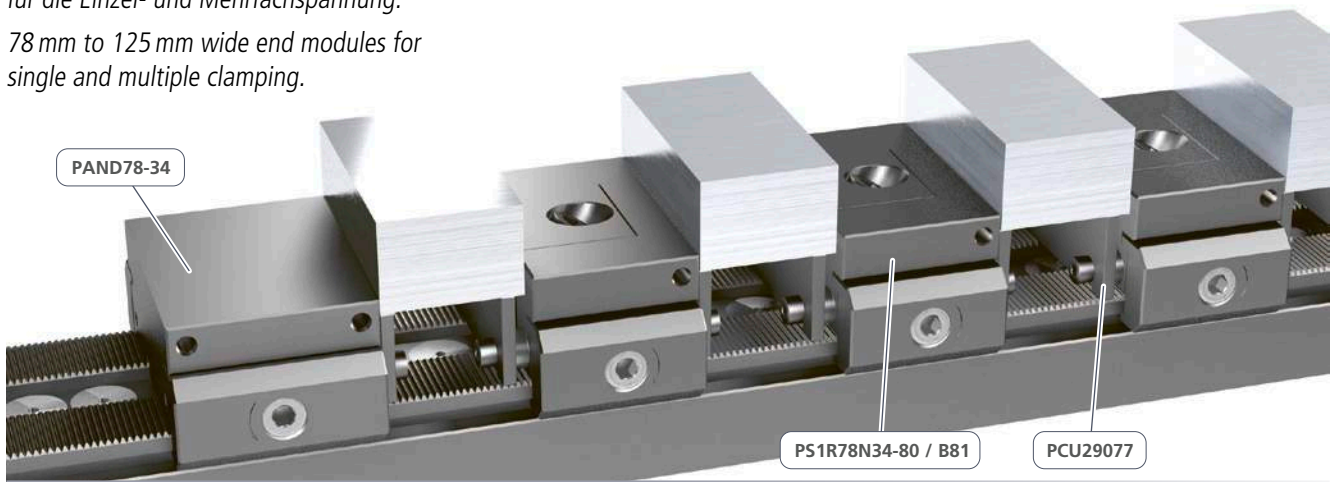

für 5-Achs Bearbeitung
for 5-axis machining

| Art. Nr. | kg | X |
|--------------------|------|-----|
| PA5X94-49F | ~1,8 | 94 |
| PA5X94-49R | ~1,8 | 94 |
| PA5X125-49F | ~2,0 | 125 |
| PA5X125-49R | ~2,0 | 125 |

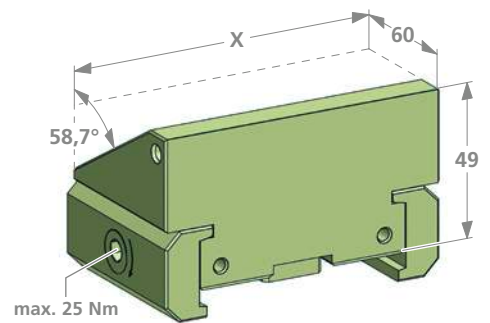

Module
einsetzbar auf
Zentrischspannern
oder Basisschienen.
Modules
can be used on self
centrig vises or
base rails.

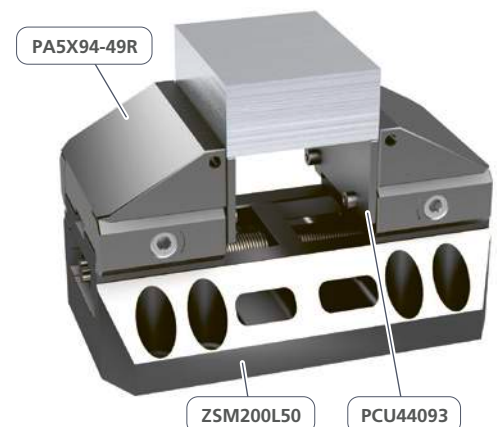
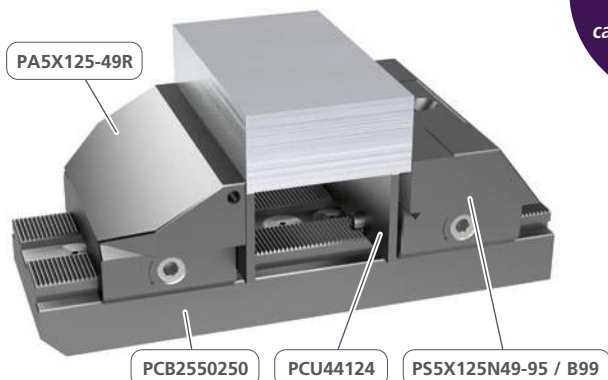

PAND48-34PRG-A1

1x TH120684

PAND48-34PRF-A1

1x TK140239
3x PCSP60R
4x PCSP60L
5x PCS14
6x PCGU2049
7x M6X8ISO7380
12x M5X10ISO4762

X = 48
H = 34
H1 = 15
kg ~1,1

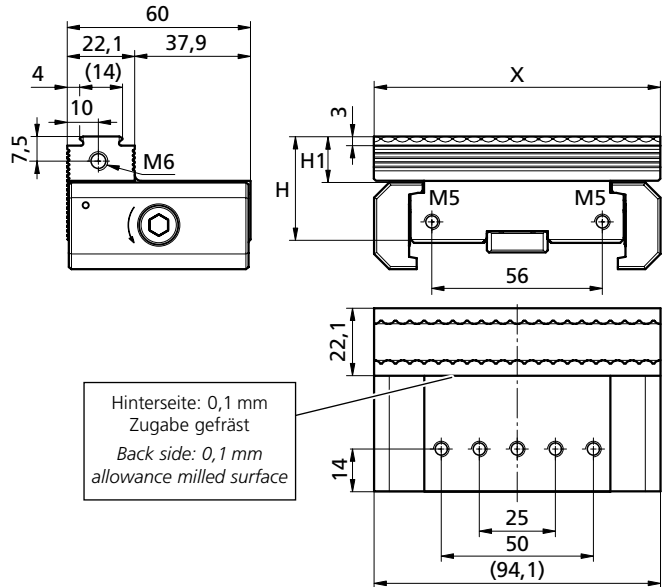
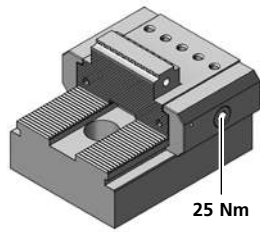

PAND48-49PRG-A1

1x TH120685

PAND48-49PRF-A1

1x TK140597

X = 48
H = 49
H1 = 30
kg ~1,3

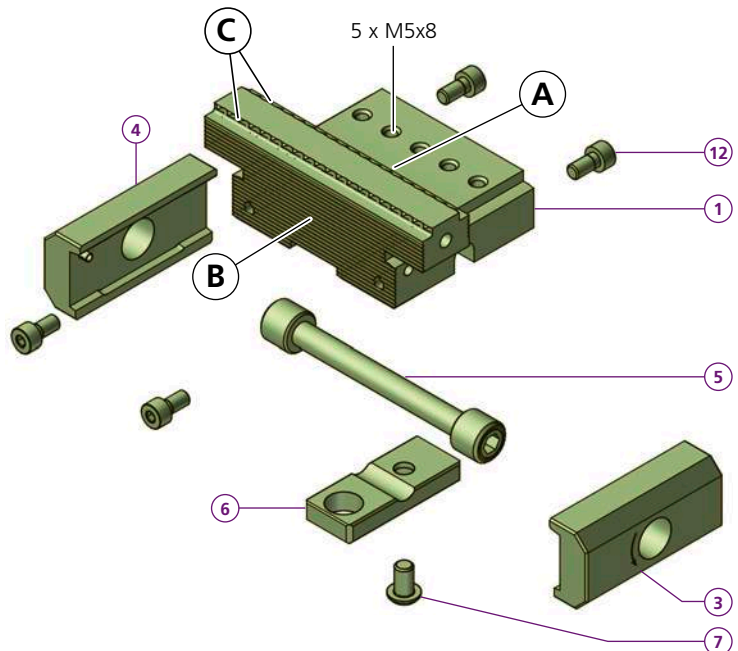
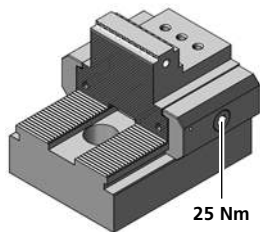

PAND94-34PRG-A1

1x TH120686

PAND94-34PRF-A1

1x TH140185

X = 94
H = 34
H1 = 15
kg ~1,2

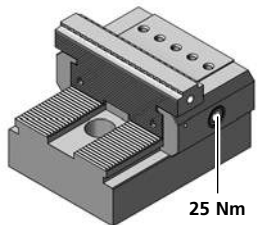

PAND94-49PRG-A1

1x TH120687

PAND94-49PRF-A1

1x TH130754

X = 94
H = 49
H1 = 30
kg ~1,6

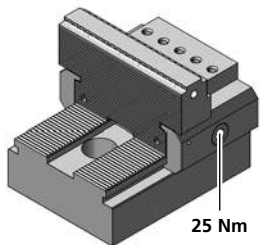

PAND125-49PRG-A1

1x TB160295

X = 125
H = 49
H1 = 30
kg ~1,7

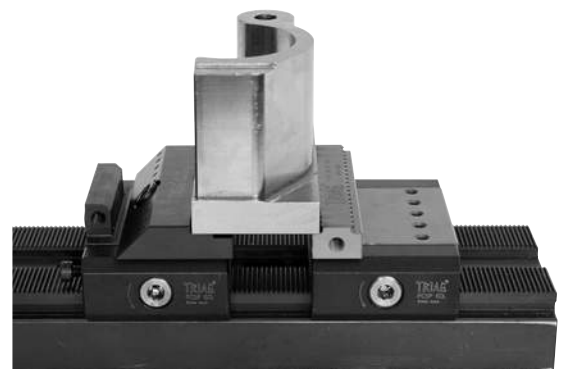
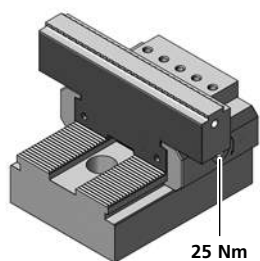

Bestellbeispiel / Ordering example: PAND94-34PRG-A1



X = 125

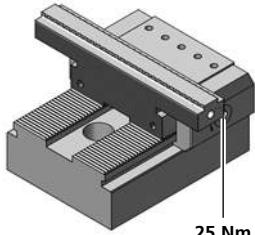

25 Nm

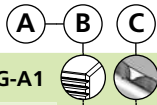

PAND125-34PRG-A1

- 1 1x TB180899
- X = 125
- kg ~1,2

PAND150-34PRG-A1

- 1 1x TB160145
- 3 1x PCSP50R
- 4 1x PCSP50L
- 5 1x PCS14
- 6 1x PCGU2049
- 7 1x M6X8ISO7380
- 12 4x M5X10ISO4762
- X = 150
- kg ~1,2

X = 150

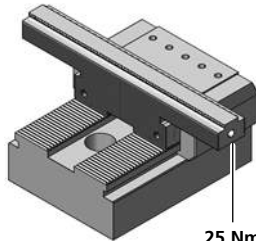

25 Nm

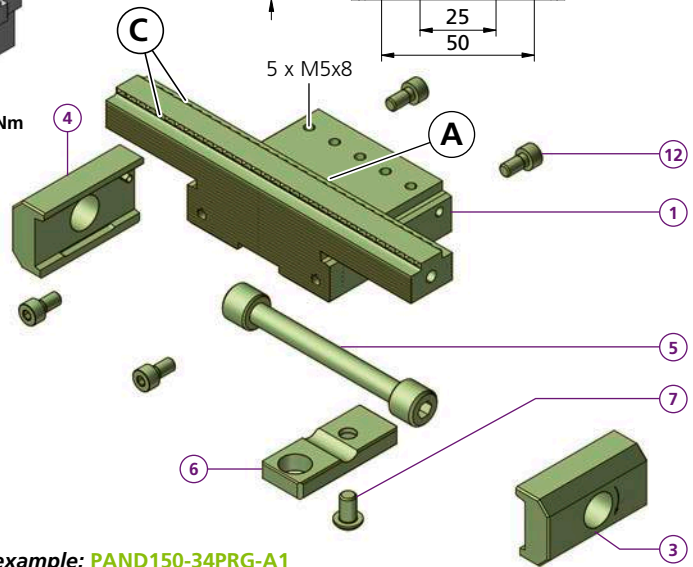
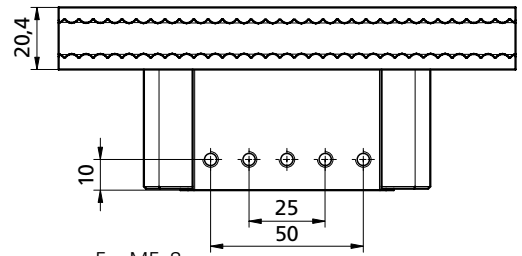
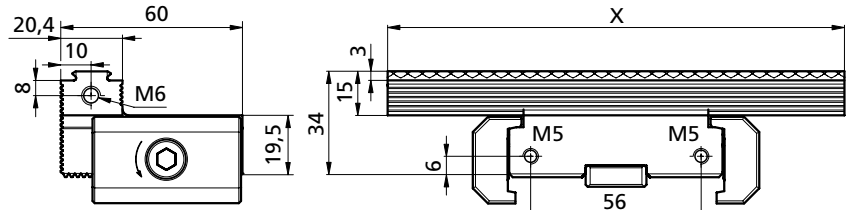

Bestellbeispiel / Ordering example: PAND150-34PRG-A1

H = 34

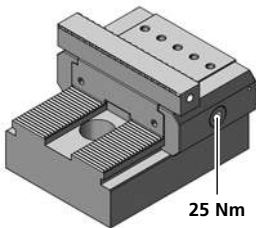

25 Nm



PAND94-34PRGV

- 1 1x TH171180
- 3 1x PCSP60R
- 4 1x PCSP60L
- 5 1x PCS14
- 6 1x PCGU2049
- 7 1x M6X8ISO7380
- 12 4x M5X10ISO4762
- H = 34
- H1 = 15
- A = 17,5
- kg ~1,2

PAND94-49PRGV

- 1 1x TH171179
- H = 49
- H1 = 30
- A = 17
- kg ~1,6

H = 49

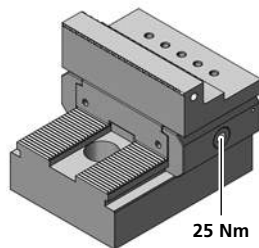

25 Nm

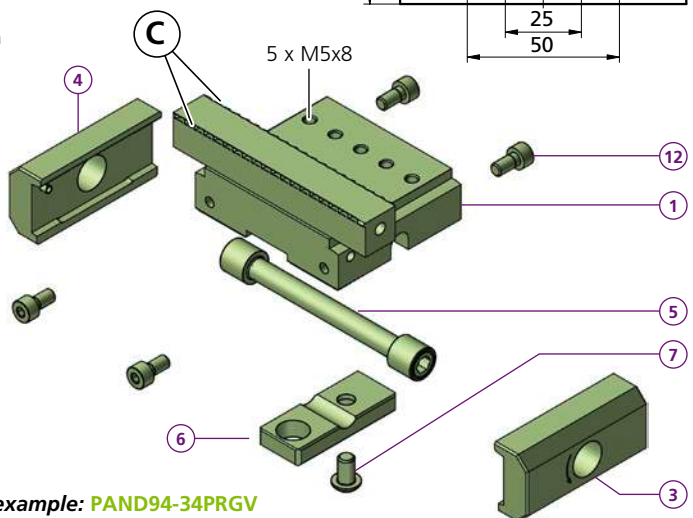
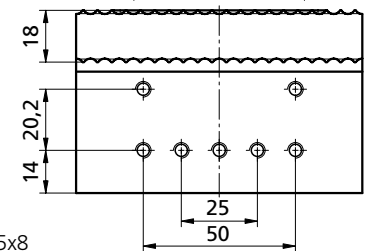
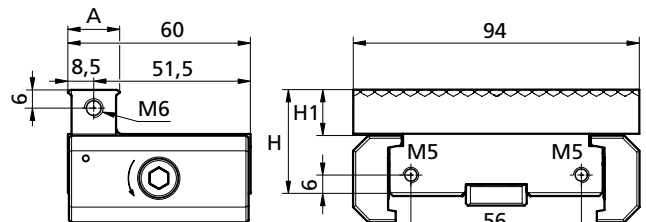





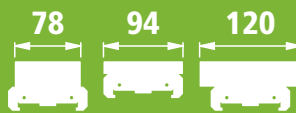

Bestellbeispiel / Ordering example: PAND94-34PRGV

Anschlagmodule zum Prägen ... End modules for stamping ...



**5axes
powerCLAMP**

für die horizontale und vertikale Bearbeitung
for horizontal and vertical machining

| Art. Nr. | | kg | Z | H |
|-------------------------|---|------|----|----|
| PAND78-34UPRG |   | ~1,2 | 60 | 34 |
| PAND78-49UPRG |   | ~1,5 | 60 | 49 |
| PAND78-34X50UPRG |   | ~1,0 | 50 | 34 |

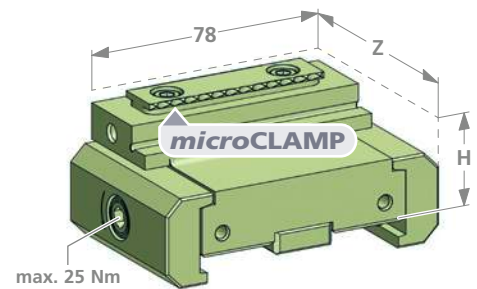

| Art. Nr. | kg |
|-----------------------|------|
| PAND120-49UPRG | ~1,8 |

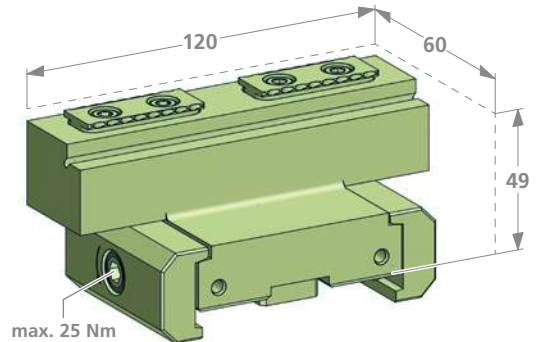

| Art. Nr. | kg |
|-----------------------|------|
| PANF94-34PRGM8 | ~1,5 |

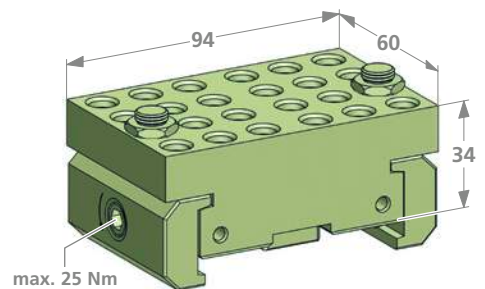

Module einsetzbar auf Zentrischspannern oder Basisschienen.

Modules can be used on self centrig vises or base rails.

Der Einsatz dieser Spannmodule erweitert die Spannmöglichkeiten für runde und unförmige Werkstücke erheblich.

The use of these clamping modules expands the clamping possibilities for round and bulky workpieces considerably.

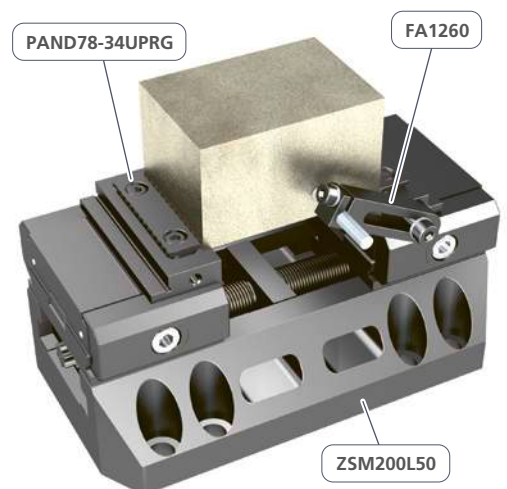
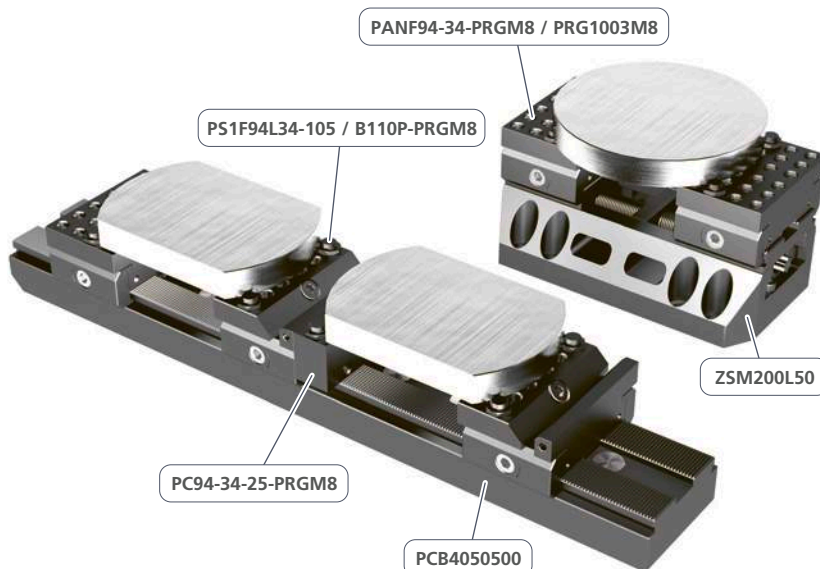

Bei knapp gespannten Werkstücken sind direkt-Prägebacken die ideale Wahl zum spannen.

For tight clamped workpieces, direct stamping jaws are the ideal choice for clamping.

Rohlingsmodule
Blank module

PT-F80-30X60
PT-F80-30X60NS
PT-F80-30X30NS

PT-F61-25X60
PT-F61-25X50
PT-F61-25X30

5axes
powerCLAMP

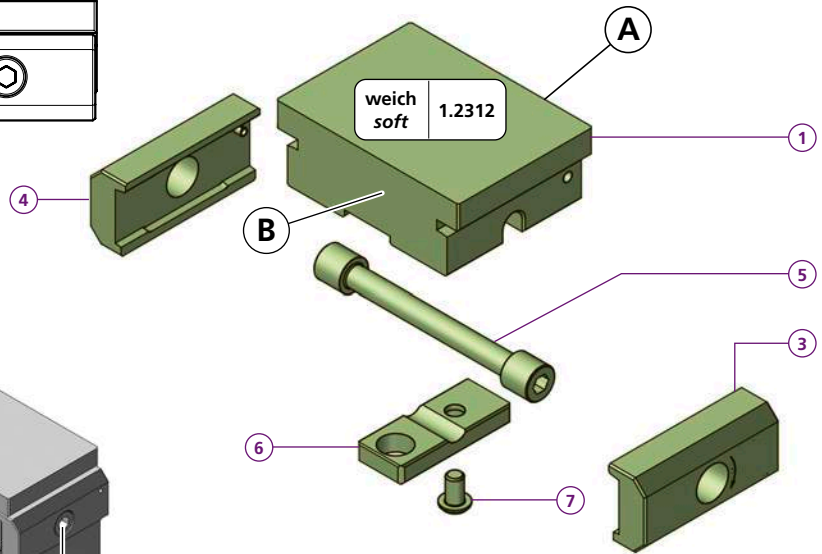
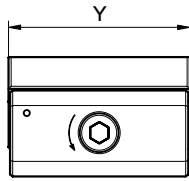
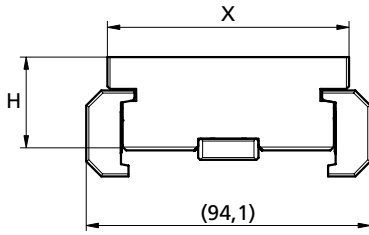

PT-F80-30X60

- 1 1x TF140637
- 3 1x PCSP60R
- 4 1x PCSP60L
- 5 1x PCS14
- 6 1x PCGU2049
- 7 1x M6X8ISO7380

X = 80
H = 30
Y = 60
kg ~1,4

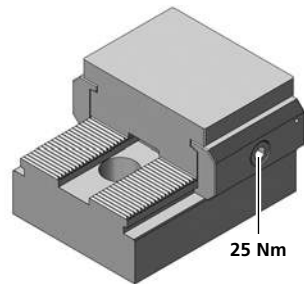

PT-F80-30X60NS

NS = Rohlingsmodul freie Positionierung ohne Verzahnung
Carrier module without positioning serration for free positioning

- 1 1x TF140635
- 3 1x PCSP60R
- 4 1x PCSP60L
- 5 1x PCS14
- 6 1x PCGU2049
- 7 1x M6X8ISO7380

X = 80
H = 30
Y = 60
kg ~1,4

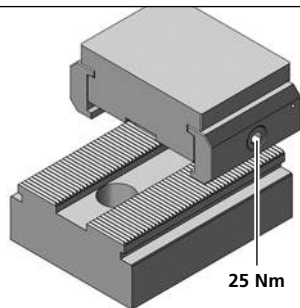

PT-F80-30X30NS

NS = Rohlingsmodul freie Positionierung ohne Verzahnung
Carrier module without positioning serration for free positioning

- 1 1x TF140749
- 3 1x PCSP30R
- 4 1x PCSP30L
- 5 1x PCS14
- 6 1x PCGU2030
- 7 1x M6X8ISO7380

X = 80
H = 30
Y = 30
kg ~0,7

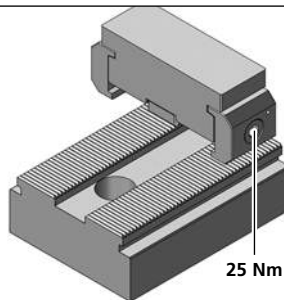

PT-F61-25X60

- 1 1x TF140638
- 3 1x PCSP60R
- 4 1x PCSP60L
- 5 1x PCS14
- 6 1x PCGU2049
- 7 1x M6X8ISO7380

X = 61
H = 25
Y = 60
kg ~1,1

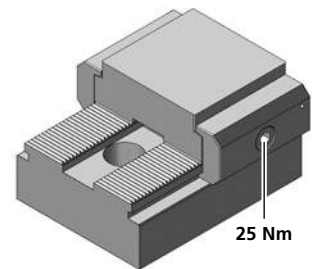

PT-F61-25X50

- 1 1x TF140750
- 3 1x PCSP50R
- 4 1x PCSP50L
- 5 1x PCS14
- 6 1x PCGU2049
- 7 1x M6X8ISO7380

X = 61
H = 25
Y = 50
kg ~1,0

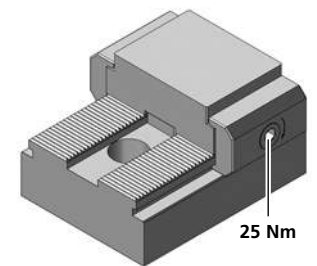

PT-F61-25X30

- 1 1x TF140636
- 3 1x PCSP30R
- 4 1x PCSP30L
- 5 1x PCS14
- 6 1x PCGU2049
- 7 1x M6X8ISO7380

X = 61
H = 25
Y = 30
kg ~0,6

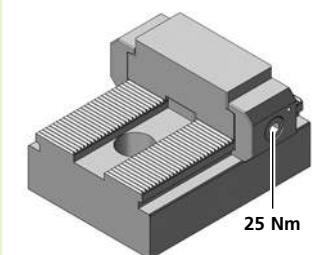

Bestellbeispiel / Ordering example: **PT-F80-30X60**

PR94-49SET

PR94-39-50SET

Rohlingsmodule
Blank module

PR125-49SETALU
PT-F132-34RDSET

PR150-49SET
PR125-49SET

5axes
powerCLAMP

A B C

- PR94-49SET**
- 1 1x PR94-49
 - 3 1x PCSP50R
 - 4 1x PCSP50L
 - 5 1x PCS14
 - 6 1x PCGU2049
 - 7 1x M6X8ISO7380
- X = 94
H = 49
Y = 60,4
kg ~2,3

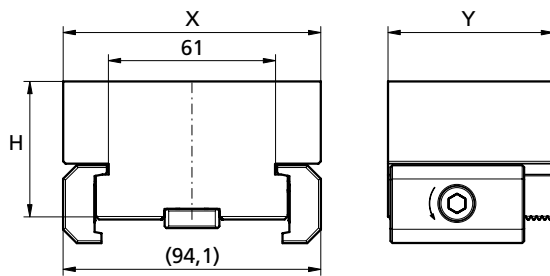
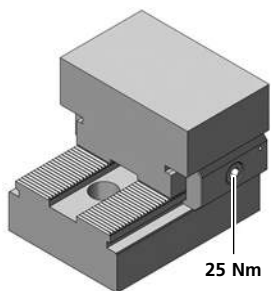

- PR94-39-50SET**
- 1 1x PR94-39-50
- X = 94
H = 39
Y = 50,4
kg ~1,6

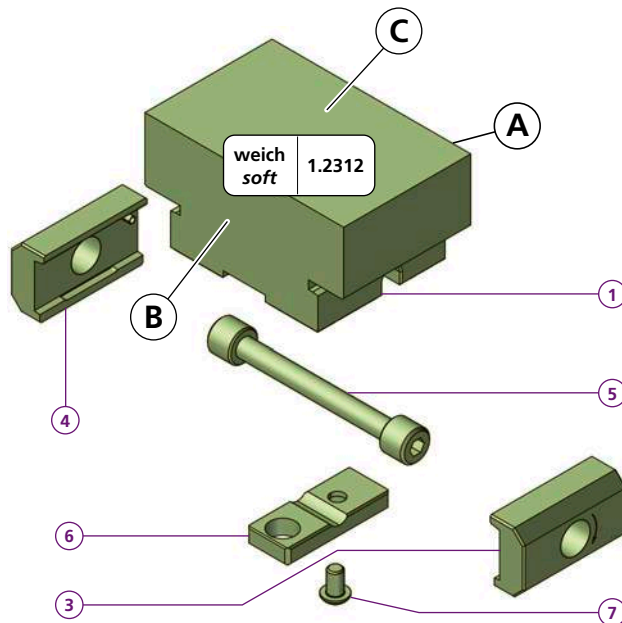
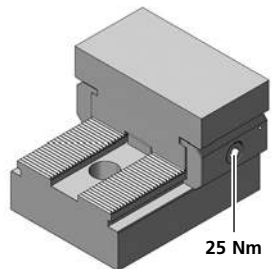

- PR125-49SET**
- 1 1x PR125-49
- X = 125
H = 49
Y = 60,4
kg ~2,7

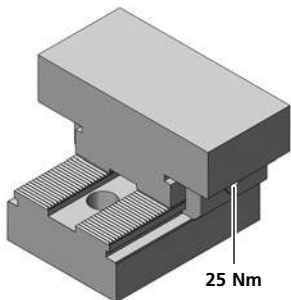

- PR125-49SETALU**
- 1 1x *PR125-49ALU
- X = 125
H = 49
Y = 60,4
kg ~0,83

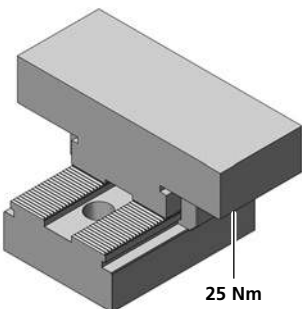

- PR150-49SET**
- 1 1x PR150-49
- X = 150
H = 49
Y = 60,4
kg ~3,1

* ALU = ENAW-7022 Bestellbeispiel / Ordering example: PR94-49SET

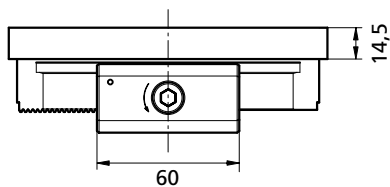
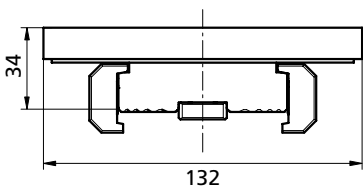

- PT-F132-34RDSET**
- 1 1x PT-F132-34RD
 - 3 1x PCSP60R
 - 4 1x PCSP60L
 - 5 1x PCS14
 - 6 1x PCGU2059
 - 7 1x M6X8ISO7380
- kg ~3,1

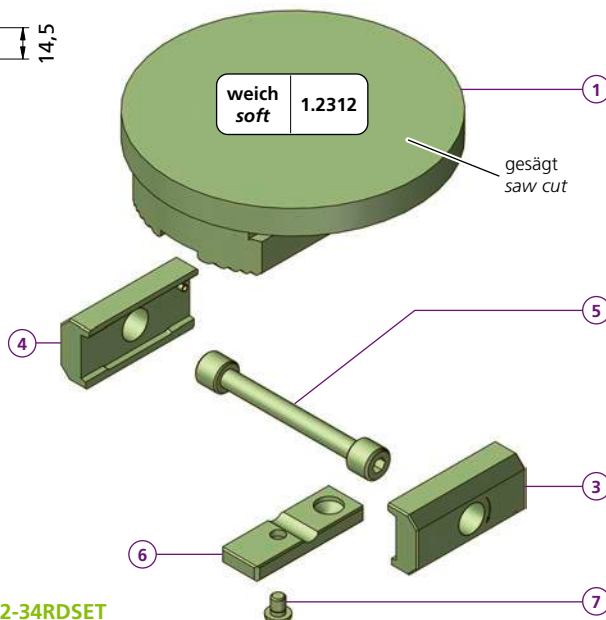
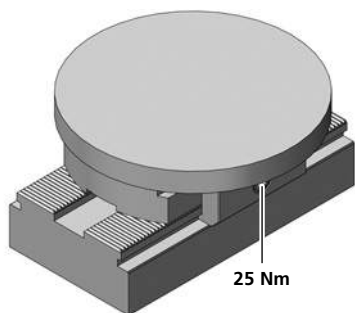

Bestellbeispiel / Ordering example: PT-F132-34RDSET

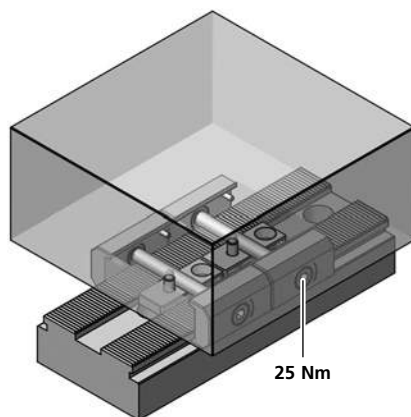
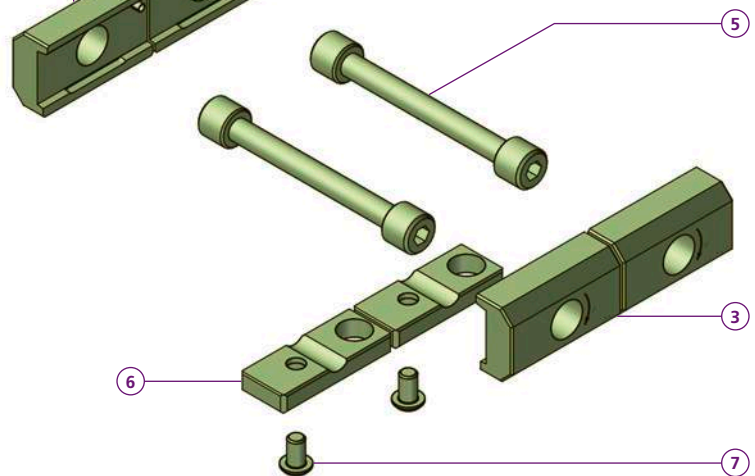
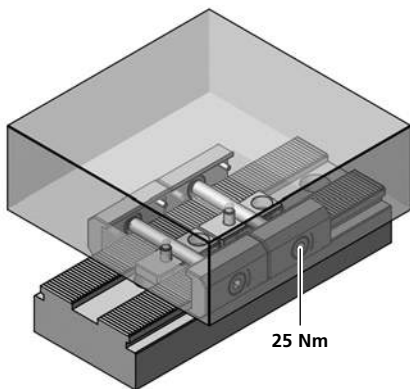
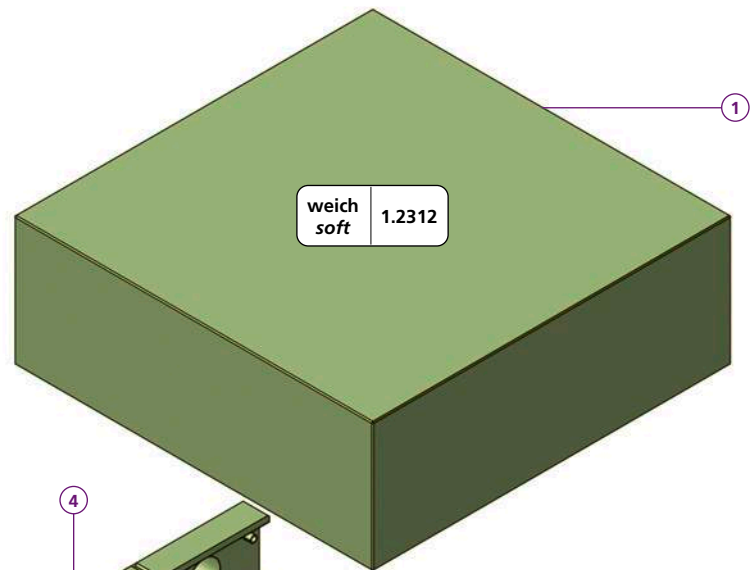
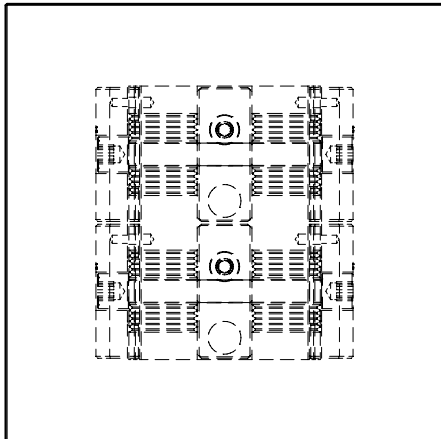
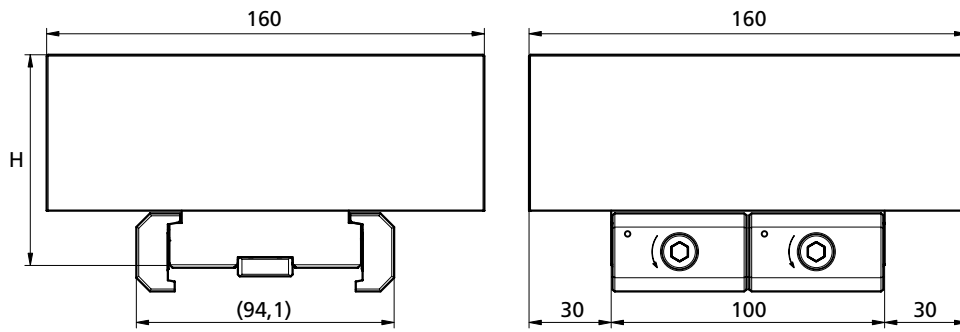

PTX160-57S

- ① 1x TH130539
- ③ 2x PCSP50R
- ④ 2x PCSP50L
- ⑤ 2x PCS14
- ⑥ 2x PCGU2049
- ⑦ 2x M6X8ISO7380

H = 57

kg ~9

PTX160-77S

- ① 1x TH130723

H = 77

kg ~13

Bestellbeispiel / Ordering example: **PTX160-57S**

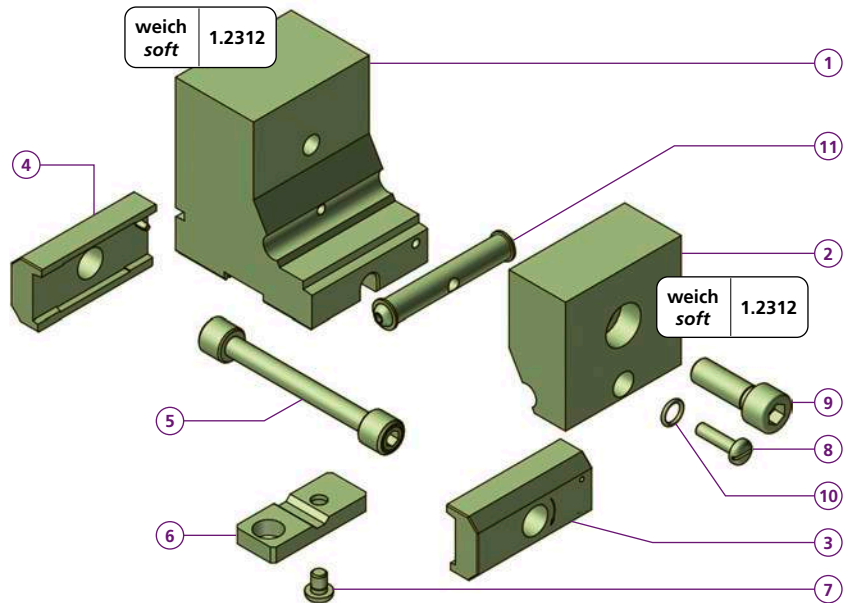
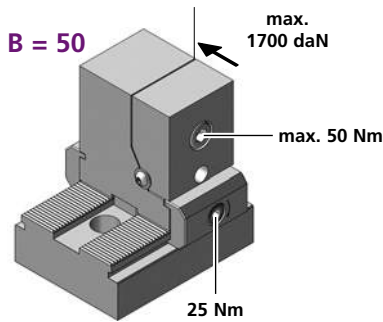
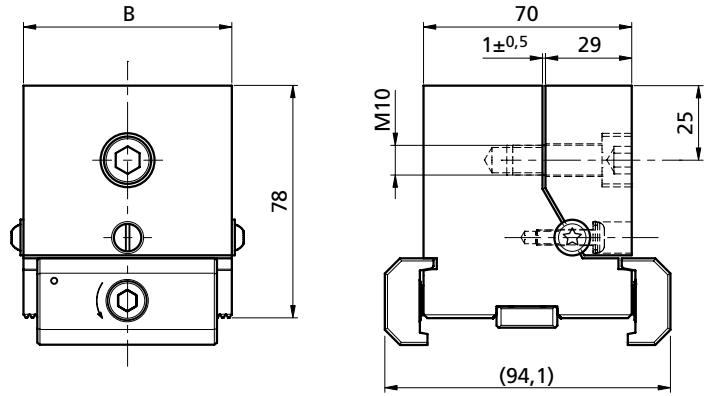
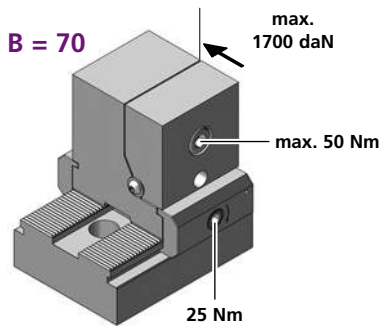

- PS1X70L78ST**
- ① 1x PRS7078AST
 - ② 1x PRS7078SST
 - ③ 1x PCSP60R
 - ④ 1x PCSP60L
 - ⑤ 1x PCS14
 - ⑥ 1x PCGU2049
 - ⑦ 1x M6X8ISO7380
 - ⑧ 1x M5X20BN1362
 - ⑨ 1x M10X30ISO4762
 - ⑩ 1x OR Ø 8x1,5
 - ⑪ 1x PRS7078G
- B** = 70
kg ~3,2

- PS1X50L78ST**
- ① 1x PRS5078AST
 - ② 1x PRS5078SST
 - ③ 1x PCSP50R
 - ④ 1x PCSP50L
 - ⑪ 1x PRS5078G
- B** = 50
kg ~2,3

- PRS70L78ST**
- ① 1x PRS7078AST
 - ② 1x PRS7078SST
 - ⑪ 1x PRS7078G
- B** = 70
kg ~2,8

- PRS50L78ST**
- ① 1x PRS5078AST
 - ② 1x PRS5078SST
 - ⑪ 1x PRS5078G
- B** = 50
kg ~2,0

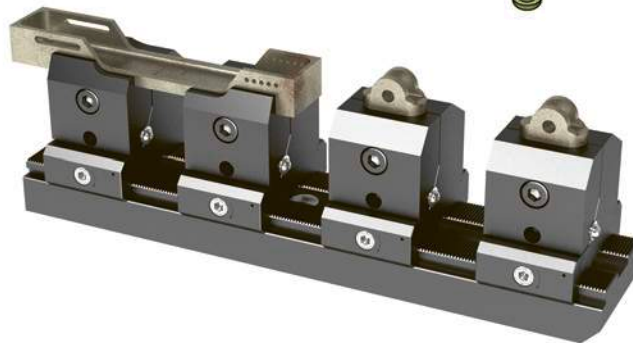

| Drehmoment Torque | | Spannkraft Workholding force | | |
|----------------------|---------|---------------------------------|-------|-----|
| Nm | (lb-ft) | ~daN | ~(lb) | ~t |
| 10 | 7,4 | = 400 | 880 | 0,4 |
| 20 | 14,8 | = 800 | 1'760 | 0,8 |
| 30 | 22,2 | = 1'200 | 2'650 | 1,2 |
| 40 | 29,6 | = 1'600 | 3'530 | 1,6 |

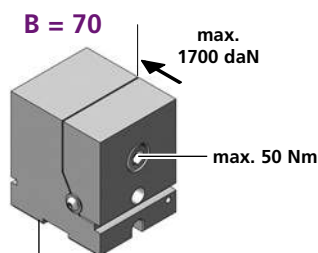

PRS = Rohlingsmodul ohne Spannpratzen
Blank module side clamp



Spannbacken Rohling auf Kundenwunsch angepasst
Jaw blank machined to customer specification

Bestellbeispiel / Ordering example: **PS1X70L78ST**



Anschlagmodul für runde Werkstücke
Endmodule for round workpieces

| Art. Nr. | | Ø | X | kg |
|-------------------------|--|---------|----|-------|
| PAND30-34RV12-35 | | 12 – 35 | 30 | ~1,1 |
| PAND61-34RV35-80 | | 35 – 80 | 61 | ~1,26 |

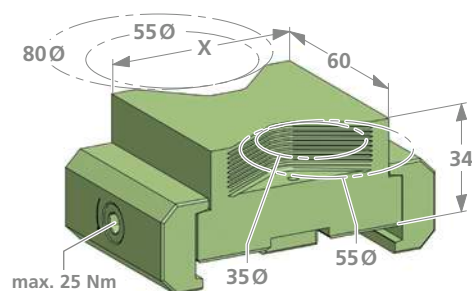
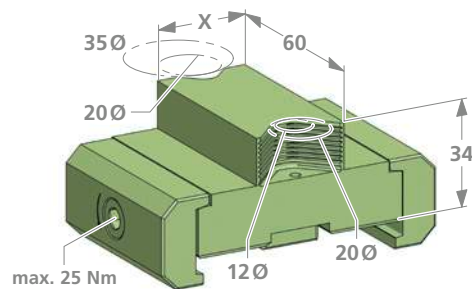

Runde Werkstücke, die einen Durchmesserbereich von 12 – 80 mm abdecken, können auf vielfältige Art gespannt werden.

Round workpieces covering a diameter range from 12 - 80 mm can be clamped in a variety of ways.

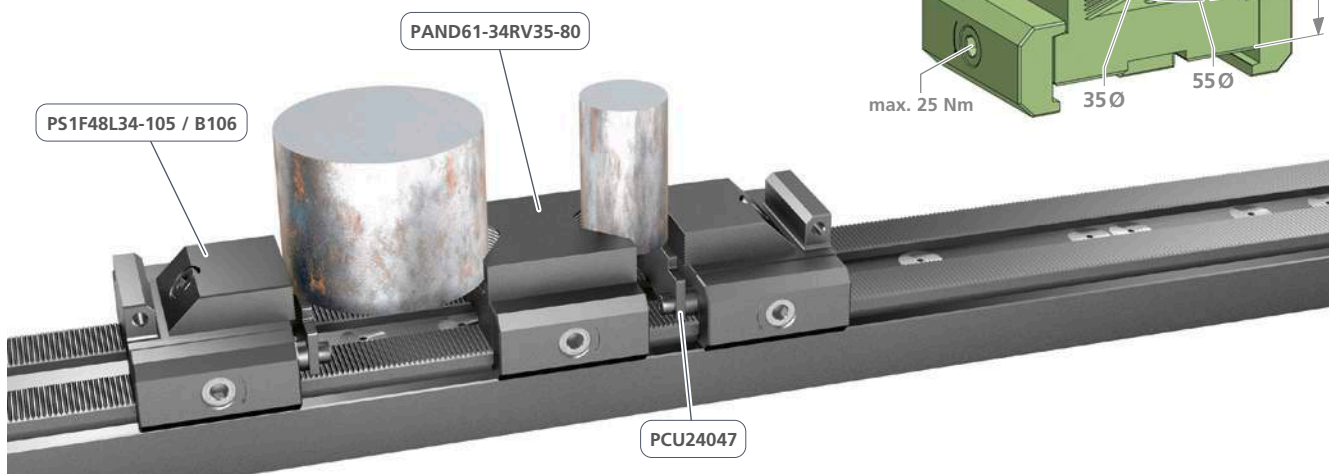

Module einsetzbar auf Zentrischspannern oder Basisschienen.
Modules can be used on self centrig vises or base rails.

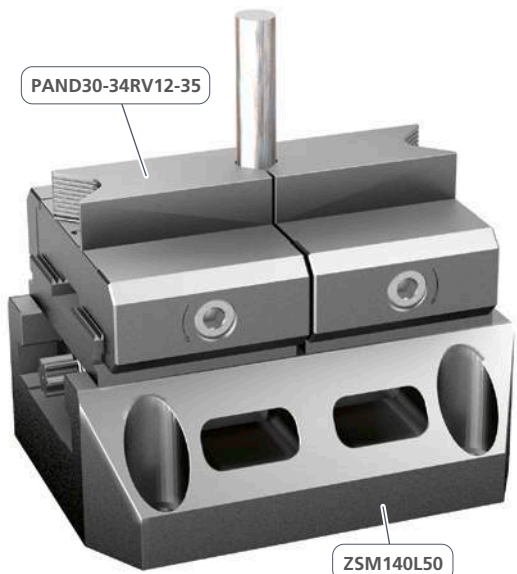
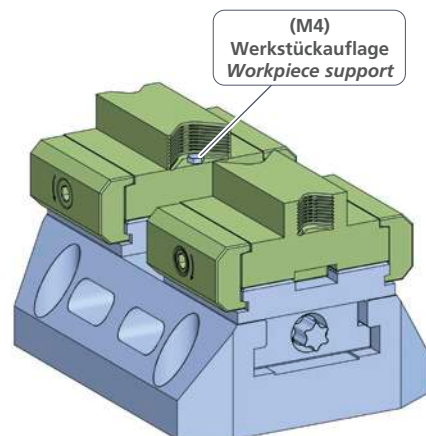

| Drehmoment Torque | | Spannkraft Workholding force | | |
|----------------------|---------|---------------------------------|-------|-----|
| Nm | (lb-ft) | ~daN | ~(lb) | ~t |
| 10 | 7,4 | = 200 | 440 | 0,2 |
| 20 | 14,8 | = 500 | 1'102 | 0,5 |
| 30 | 22,2 | = 1'000 | 2'204 | 1,0 |
| 40 | 29,6 | = 1'300 | 2'866 | 1,3 |
| 50 | 37,0 | = 1'600 | 3'527 | 1,6 |

NUSS3/8"TX30E14

WICHTIG!
Bitte separat bestellen
IMPORTANT!
Please order separately



Dreibackenfutter
Three jaw chuck

PS3X80L75BSET
PS3X100L82BSET
PS3X125L87BSET

5axes
powerCLAMP

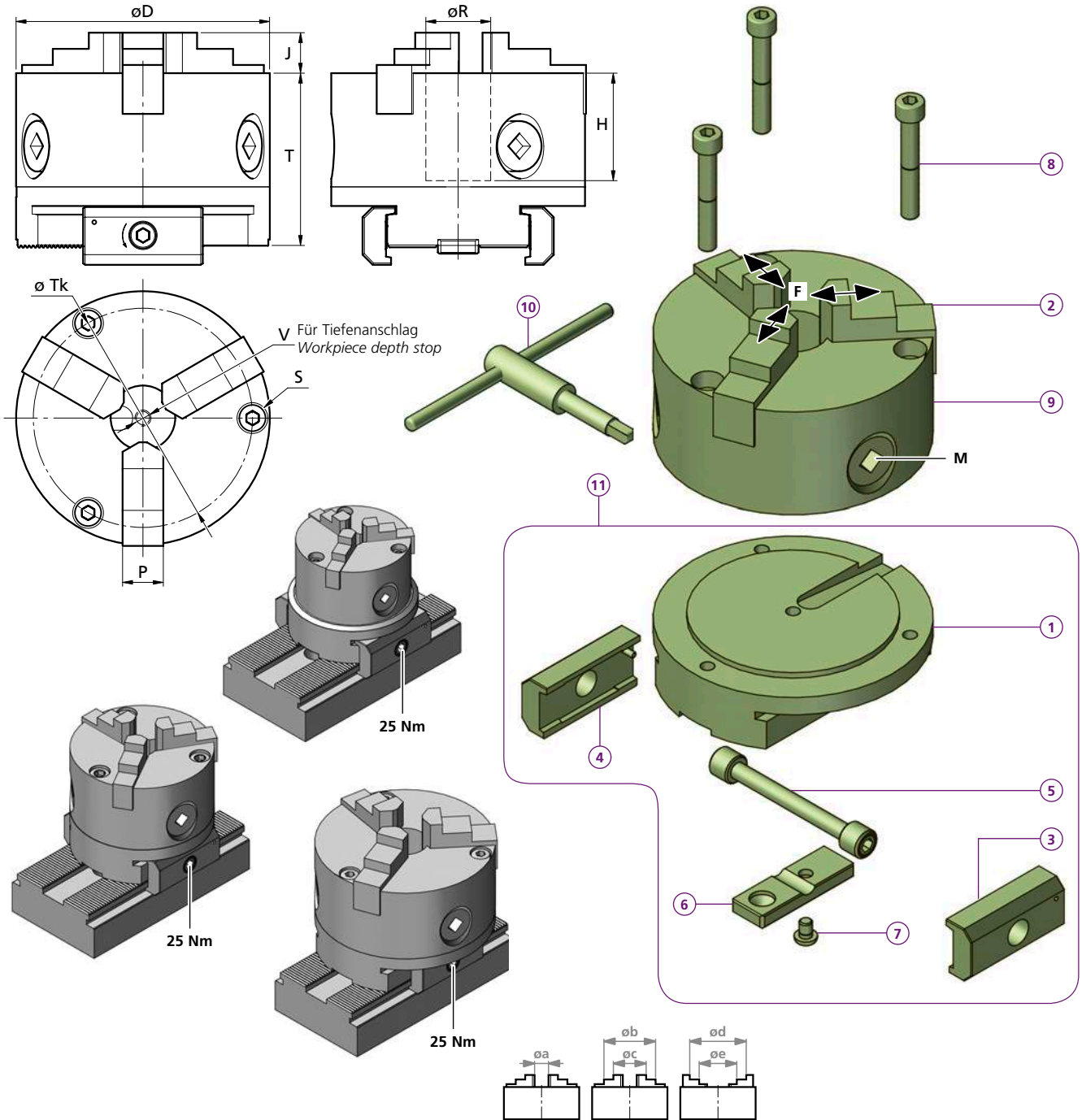

| | D | J | T | R | H | P | V | a mm | b mm | c mm | d mm | e mm | M (max.) | F (max.) | ø Tk | S |
|-----------------------|-----|----|----|----|------|----|----|--------|----------|---------|----------|---------|----------|----------|------|----|
| PS3X80L75BSET | 80 | 13 | 75 | 15 | 42,5 | 10 | M6 | 3...27 | 48...73 | 23...48 | 52...76 | 27...51 | 28 Nm | 1300 daN | 67 | M6 |
| PS3X100L82BSET | 100 | 17 | 82 | 20 | 49,5 | 14 | M8 | 3...39 | 58...94 | 24...60 | 64...100 | 30...66 | 38 Nm | 1600 daN | 83 | M8 |
| PS3X125L87BSET | 125 | 19 | 87 | 32 | 55 | 16 | M8 | 3...49 | 70...116 | 30...75 | 83...125 | 38...84 | 55 Nm | 2600 daN | 108 | M8 |

PS3X80L75BSET

- 1 1x TW090013_01
- 2 2x 3 Stk. / pcs
- 3 1x PCSP60R
- 4 1x PCSP60L
- 5 1x PCS14
- 6 1x PCGU2059
- 7 1x M6X8ISO7380
- 8 3x M6X45ISO4762
- 9 1x 243809.0083220
- 10 1x 243864.0080000
- 11 PTX80-30

kg ~2,8

PS3X100L82BSET

- 1 1x TW090012_01
- 2 2x 3 Stk. / pcs
- 8 3x M8X50ISO4762
- 9 1x 243809.0103220
- 10 1x 243864.0100000
- 11 PTX100-30

kg ~4,3

PS3X125L87BSET

- 1 1x TW080027_01
- 2 2x 3 Stk. / pcs
- 8 3x M8X55ISO4762
- 9 1x 243809.0123220
- 10 1x 243864.0120000
- 11 PTX125-29

kg ~6,3

Ø 80
100
125

243849.0083200 243850.0083200 *243834.0083300
243849.0103200 243850.0103200 *243834.0103300
243849.0123200 243850.0123200 *243834.0123300

3x
3x
3x

Ø 3 - 49 Ø 38 - 125

16MnCr5

Bestellbeispiel / Ordering example: **PS3X125L87BSET**

Separat bestellen / Order separately

Spannzangenmodule Collet modules

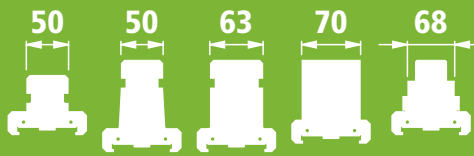

**5axes
powerCLAMP**

für die horizontale und vertikale Bearbeitung
for horizontal and vertical machining

| Art. Nr. | kg | Ø | Y | H |
|------------------------|------|------|----|-----|
| PS1X50N62-ER32 | ~1,3 | 2-22 | 60 | 62 |
| PS1X50N100-ER32 | ~2,2 | 2-22 | 60 | 100 |
| PS1X63N100-ER40 | ~2,3 | 3-29 | 80 | 100 |

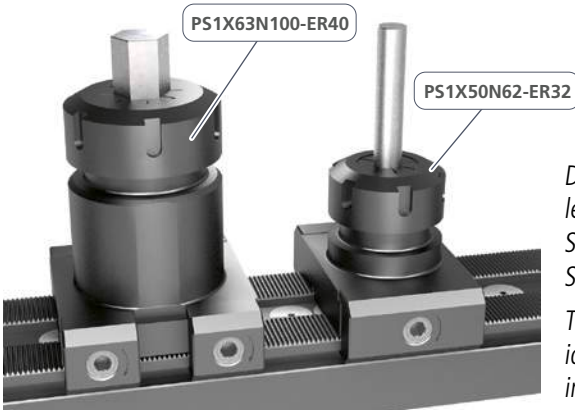
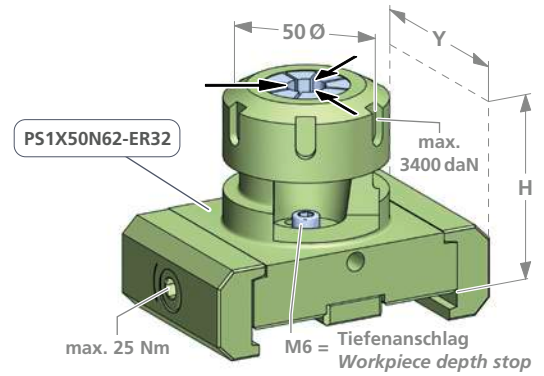

Diese Spannzangenmodule ermöglichen das ideale Spannen und Bearbeiten von Stangenmaterial.

These collet modules enable ideal clamping and machining of bar material.

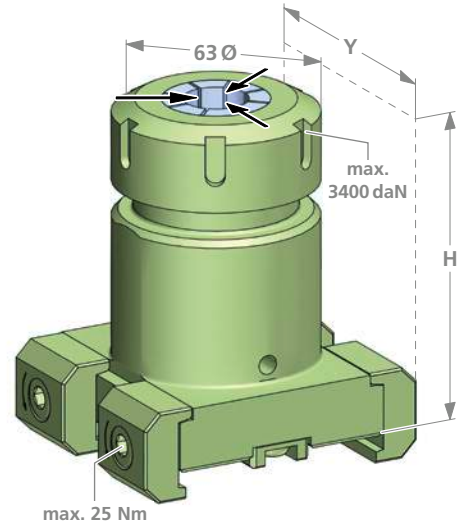

| Art. Nr. | kg | Ø |
|---------------------------|-------|------|
| PS1X50N70H-ER32-NS | ~2,98 | 2-22 |

Die seitlichen Spannpratzen können um 90° gedreht werden, dadurch kann das Spannzangenmodul auch quer zur Schiene platziert werden.

The side clamps can be turned by 90°, the module can therefore be placed crosswise to the rail.

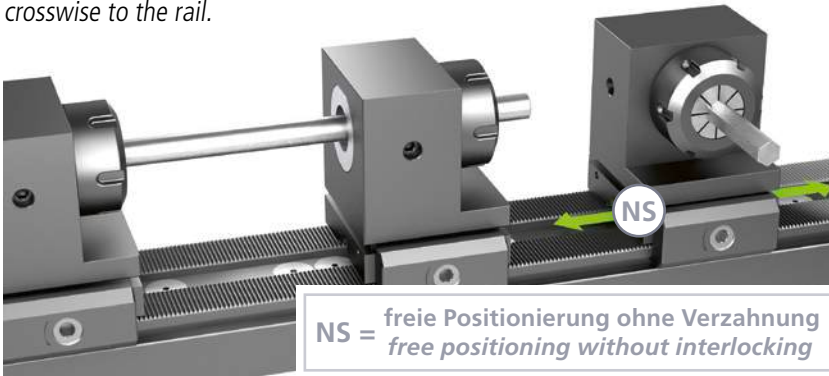

NS = freie Positionierung ohne Verzahnung
free positioning without interlocking

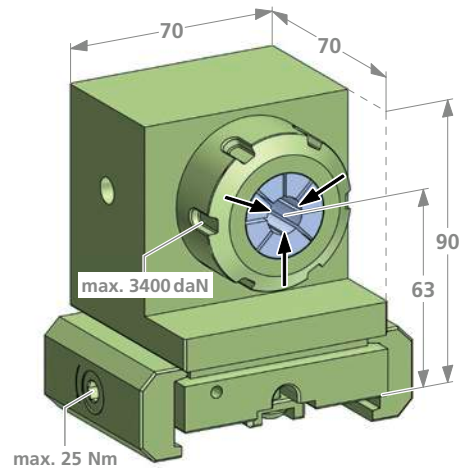

| Art. Nr. | kg | Ø | M |
|----------------------|------|--------|---------|
| PS1X68N80-W20 | ~1,8 | 0,5-20 | M37,6x3 |

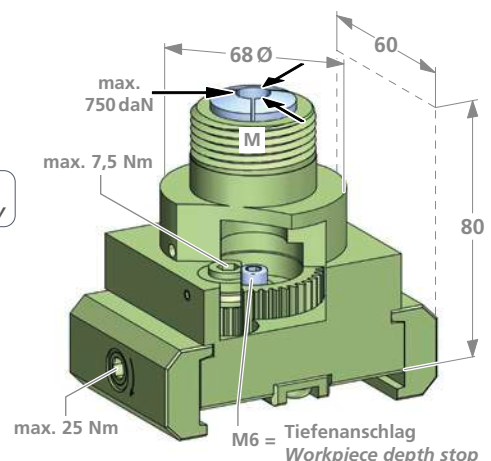
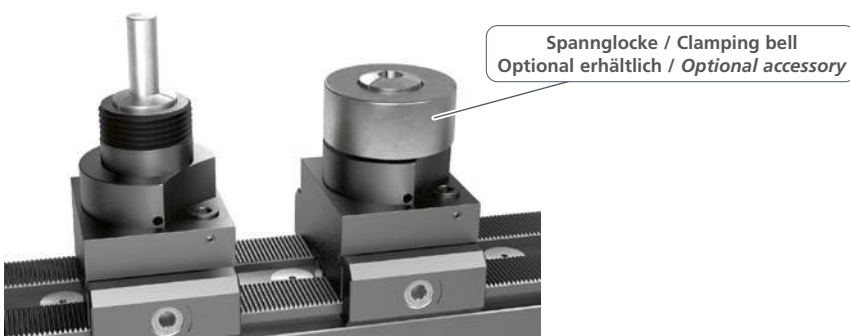

PS1F-KLD1
PS1F-KLD1NS

powerCLAMP

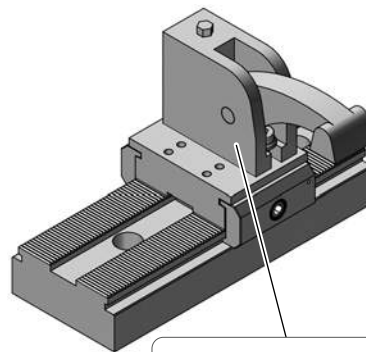
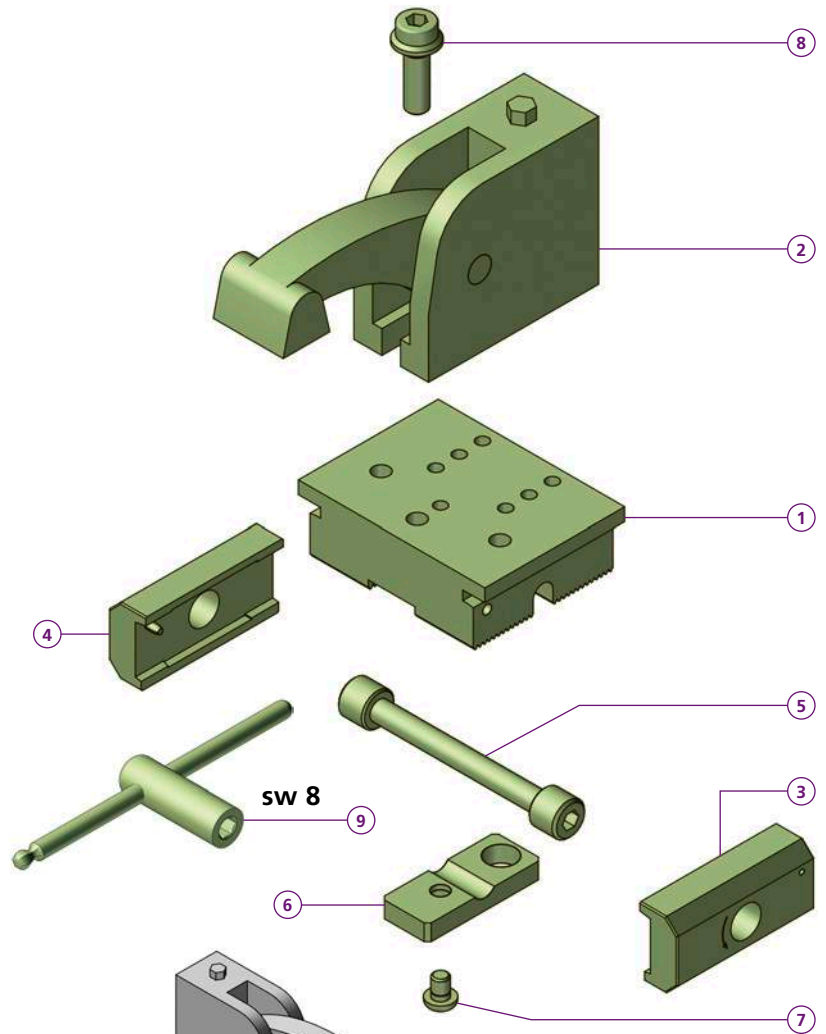
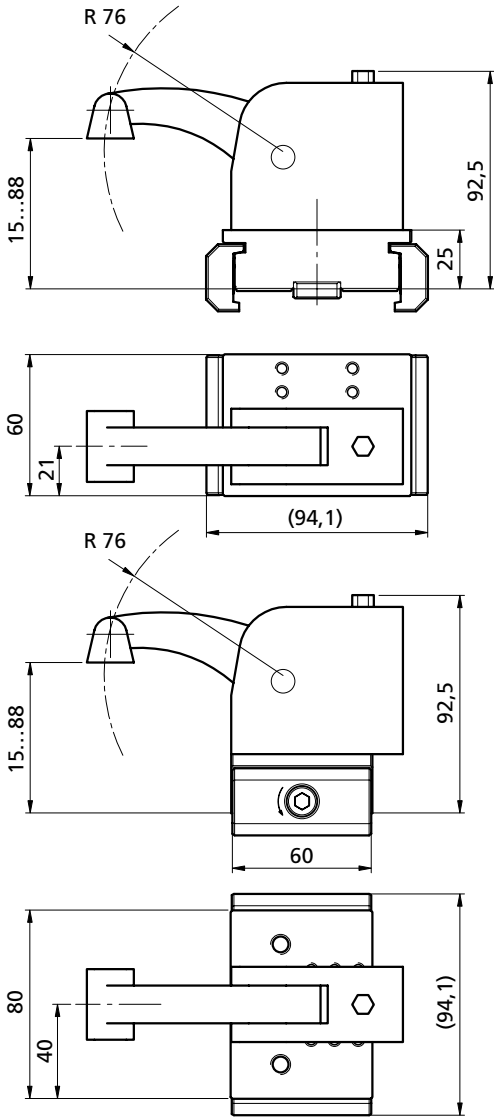

Spanner quer montiert
Clamp mounted transversely

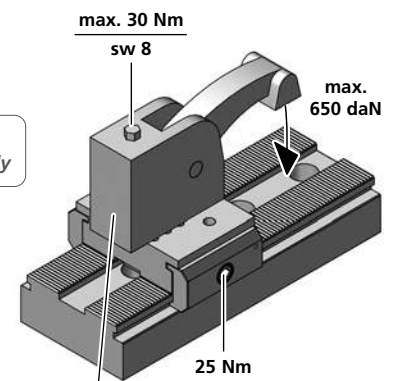

Spanner längs montiert
Clamp mounted longitudinally



NS = Trägermodul freie Positionierung ohne Verzahnung
Carrier module without positioning serration for free positioning

| PS1F-KLD1 | |
|-------------|----------------------|
| 1 | 1x PCTMV1F |
| 2 | 1x 07-020 |
| 3 | 1x PCSP60R |
| 4 | 1x PCSP60L |
| 5 | 1x PCS14 |
| 6 | 1x PCGU2049 |
| 7 | 1x M6X8ISO7380 |
| 8 | 1x M8x25 TW080012-02 |
| 9 | 1x 07-180 |
| kg | ~2,1 |
| PS1F-KLD1NS | |
| 2 | 1x PCTMV1FNS |
| kg | ~2,1 |

Bestellbeispiel / Ordering example: **PS1F-KLD1NS**

Plattenspanner / Plate clamping modul PS1F20L35BV1
Trägermodul für Micro Zentrischspanner PS1F20L35BV1NS
Support module for micro self centering vise PTX-MCZ40L30 powerCLAMP

PS1F20L35BV1

- ① 1x PCTMV1F
- ② 1x MV1F20L35BV1
- ③ 1x PCSP60R
- ④ 1x PCSP60L
- ⑤ 1x PCS14
- ⑥ 1x PCGU2049
- ⑦ 1x M6X8ISO7380

kg ~1,4

PS1F20L35BV1NS

- ① 1x PCTMV1FNS

kg ~1,4

NS = Trägermodul freie Positionierung ohne Verzahnung
Carrier module without positioning serration for free positioning

microCLAMP p. 177

max. 920 daN max. 15 Nm

25 Nm

PTX-MCZ40L30

- ① 1x ZB200681
- ② 1x TB200682
- ③ 1x PCSP60R
- ④ 1x PCSP60L
- ⑤ 1x PCS14
- ⑥ 1x PCGU2049
- ⑦ 1x TN100008

kg ~0,94

triCENTRO p. 116

Nach Ihren Bedürfnissen können die Micro Zentrischspanner ausgewählt werden.
The micro self centering vise can be selected according to your needs.

25 Nm

Bestellbeispiel / Ordering example: **PS1F20L35BV1**

Magnetspannplatte

Magnetic chuck

PS1X150L60-250MAG11

powerCLAMP

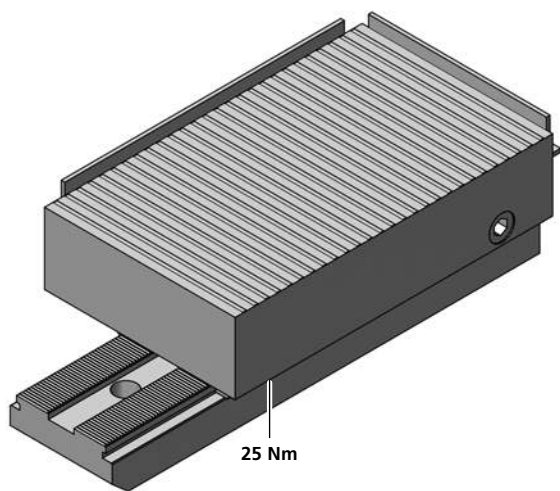
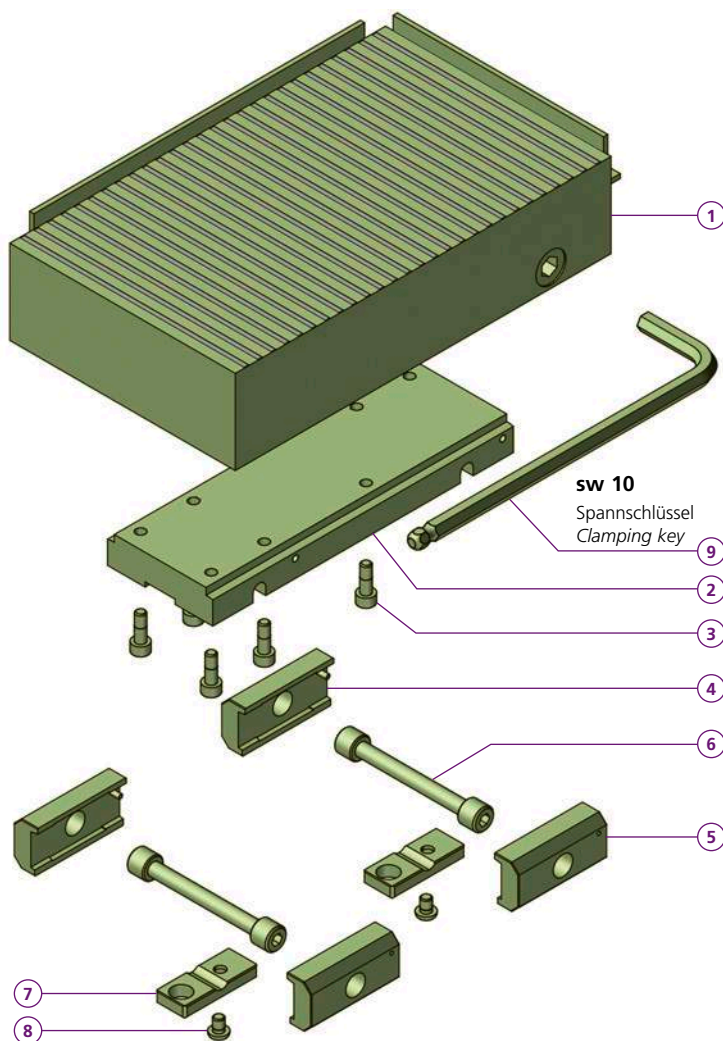
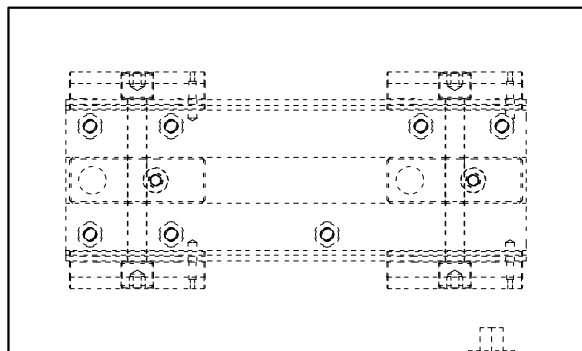
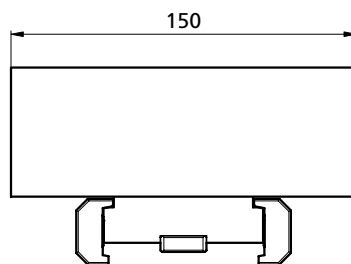
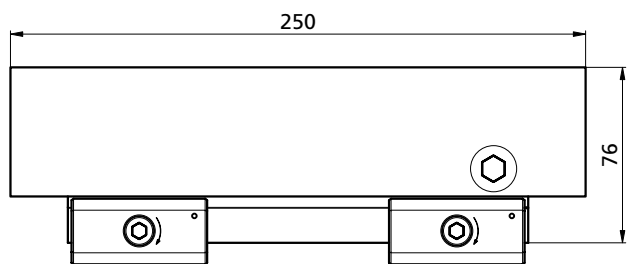

PS1X150L60-250MAG11

- 1x XNeomill 250x150
- 1x TL110010-01
- 7x MS60
- 2x PCSP60L
- 2x PCSP60R
- 2x PCS14
- 2x PCGU2049
- 2x M6X8ISO7380
- 1x ISL10 DIN 911L

kg ~19,5

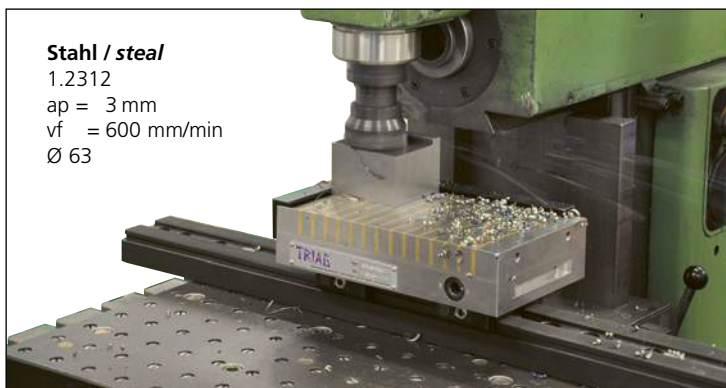

Stahl / steel
 1.2312
 ap = 3 mm
 vf = 600 mm/min
 Ø 63

max. Haltekraft / max. holding force = 120 N/cm²

- Werkstücke ab 26 mm Länge und 6 mm Stärke werden optimal gespannt
- Workpieces from 26 mm length and 6mm thickness will be optimally hold

Bestellbeispiel / Ordering example: PS1X150L60-250MAG11

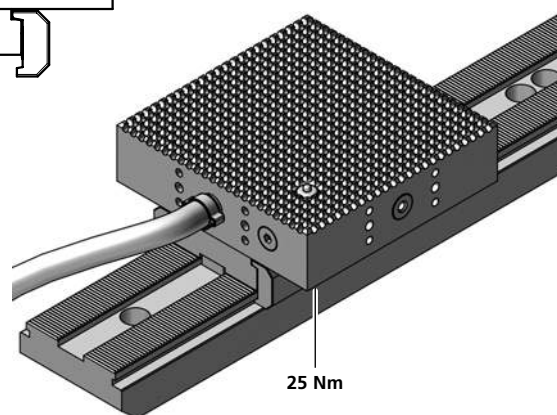
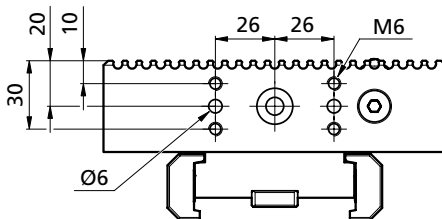
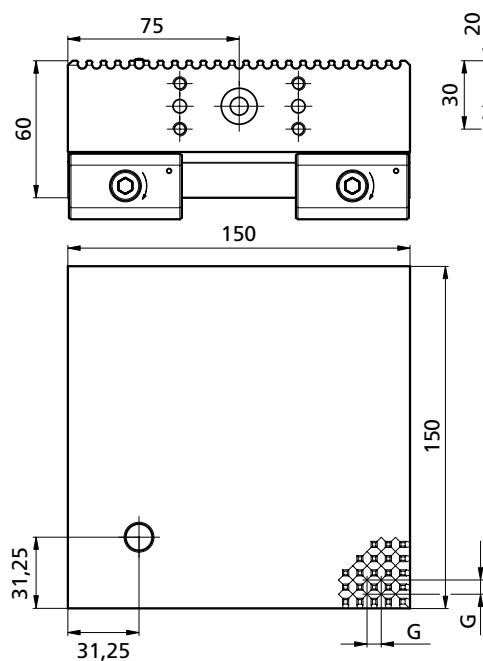

trivaCLAMP p. 318

Mehr Informationen siehe Vacuum
For more information check the vacuum workholding

Bestellbeispiel / Ordering example: PS1X150L60-VAC



PCZ100L50

Mehr Informationen siehe Zentrischspanner
For more information check the self centring vise p. 126 - 132

triCENTRO p. 113 - 152

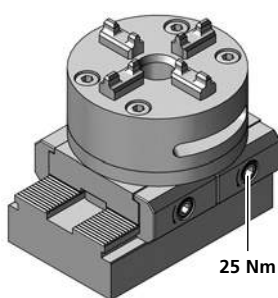
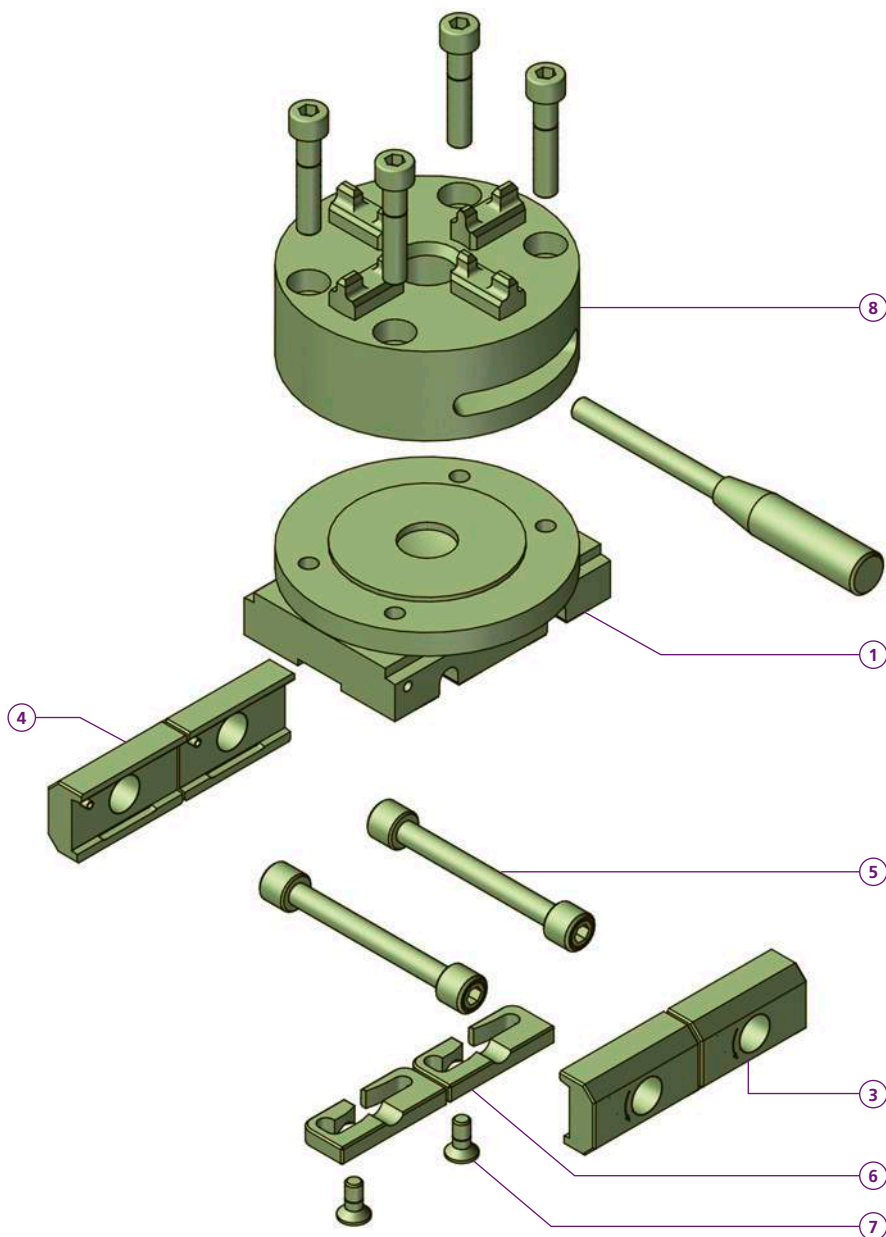
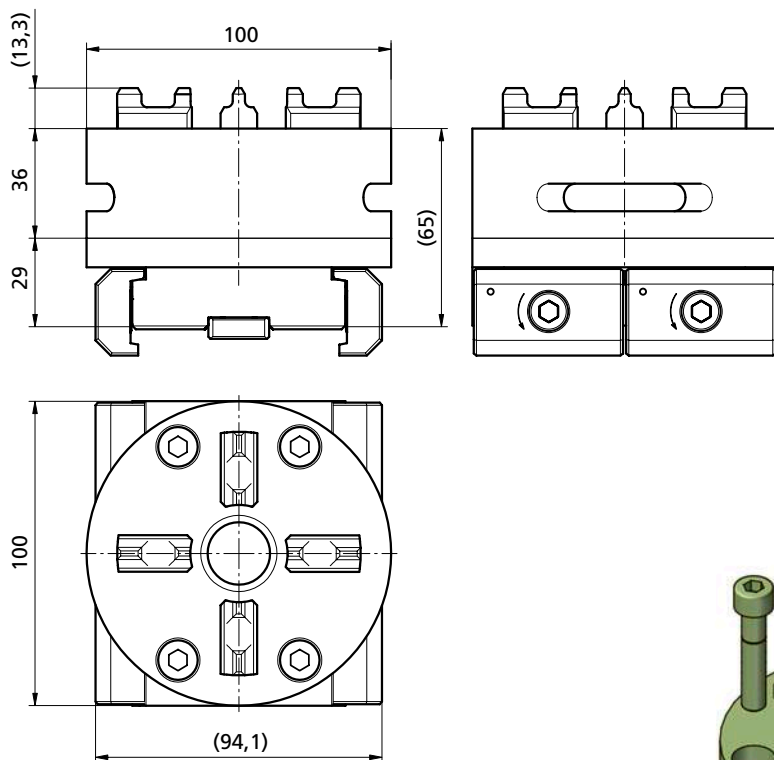

PS1X100-65ER-036345

- 1 1x PTX100-29
 - 3 2x PCSP50L
 - 4 2x PCSP50R
 - 5 2x PCS14
 - 6 2x PCGU2049F
 - 7 2x M6X14ISO10642
 - 8 1x ER-036345
- kg ~4,0

Bestellbeispiel / Ordering example: PS1X100-65ER-036345

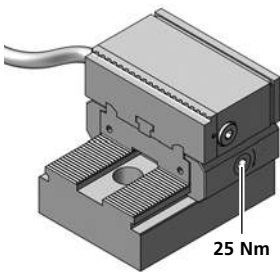
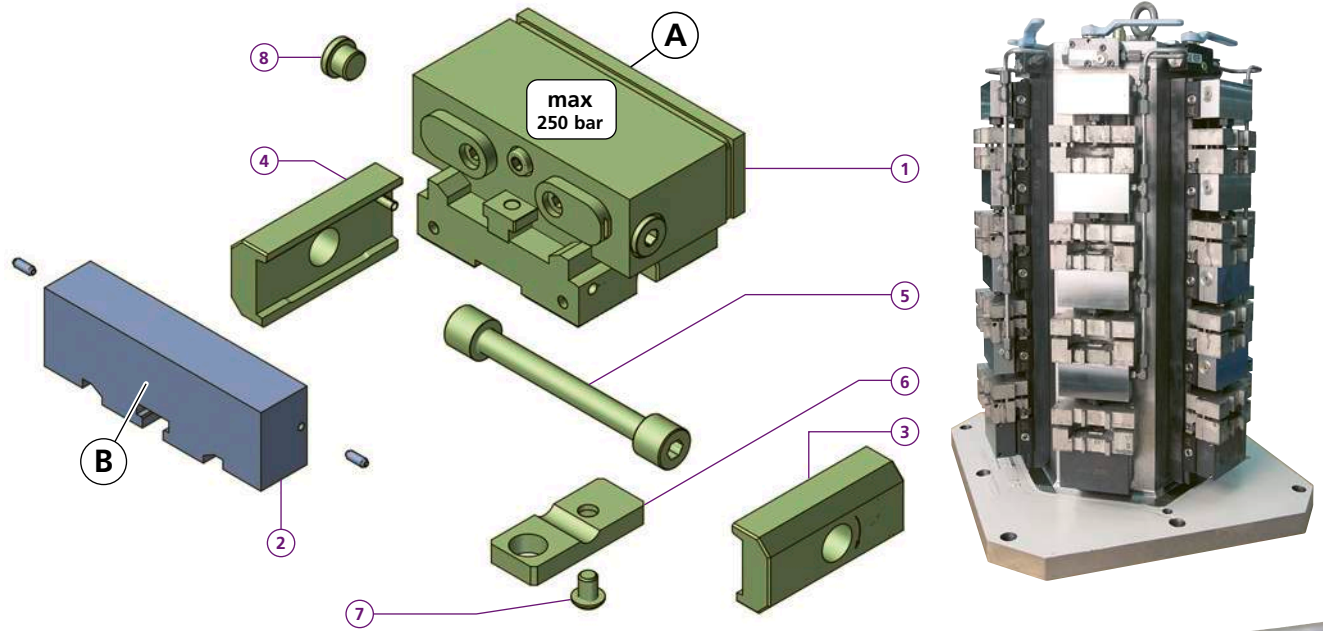
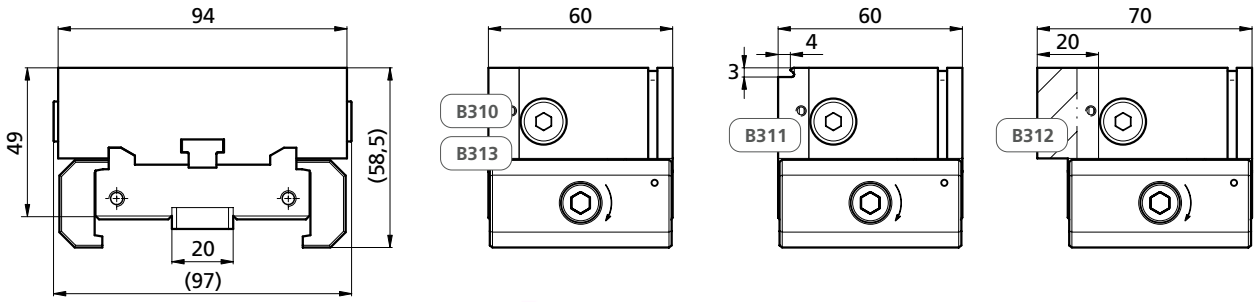

| | |
|------------------------|--|
| Ölvolumen / Oil volume | |
| Spannen / Clamping | |
| 8 cm ³ | |

| | | | |
|-------------------|---------|-------|------|
| 5 mm Hub / Stroke | | | |
| bar | ~daN | ~(lb) | ~t |
| 100 | = 960 | 2116 | 0,96 |
| 150 | = 1'440 | 3175 | 1,44 |
| 200 | = 1'920 | 4233 | 1,92 |
| 250 | = 2'400 | 5291 | 2,4 |



Bestellbeispiel / Ordering example: PSH1X94L49-310 & 1 x B310

| | B310 | B311 | B312 | B313 |
|-----------|-----------------|------------|-------|-----------------|
| C | 94 | 94 | 94 | 94 |
| H | 31,5 | 31,5 | 31,5 | 31,5 |
| L | 10 | 10 | 20 | 10 |
| i | HV700 x0,2mm | 57HRC * | * | HV700 x0,2mm |
| kg | ~0,18 | ~0,17 | ~0,39 | ~0,17 |

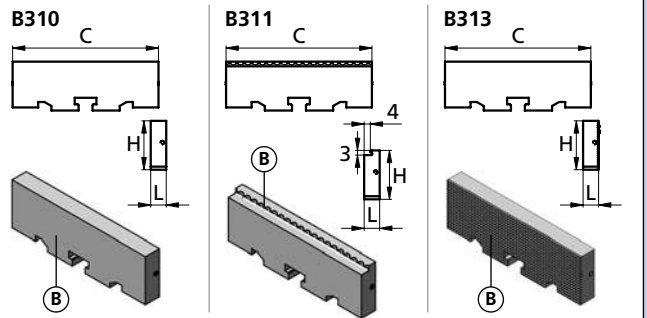

- PSH1X94L49-310**
- ① 1x ZF191349
 - ② 1x _____
 - ③ 1x PCSP60R
 - ④ 1x PCSP60L
 - ⑤ 1x PCS14
 - ⑥ 1x PCGU2049
 - ⑦ 1x M6X81507380
 - ⑧ 2x TN100014
- kg** ~1,94

B312

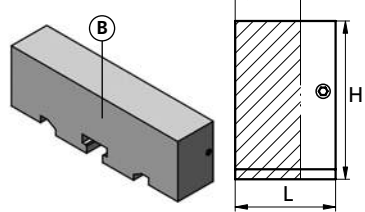

Zum Erstellen Ihrer individuellen Formbacke:

Schnittzeichnung zum Ermitteln der maximalen Bearbeitungsprofiliefe

If a dedicated jaw is being machined:
Sectional drawing to determine the maximum machining depth

für Hartmetalldruckstücke
for carbide grippers

| Art. Nr. | kg | Y | X |
|----------------|-------|-----|----|
| PC4349 | ~0,21 | 43 | 49 |
| PC4834 | ~0,17 | 48 | 34 |
| PC12549 | ~0,46 | 125 | 49 |

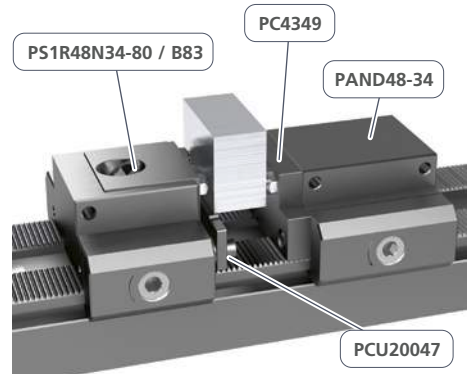
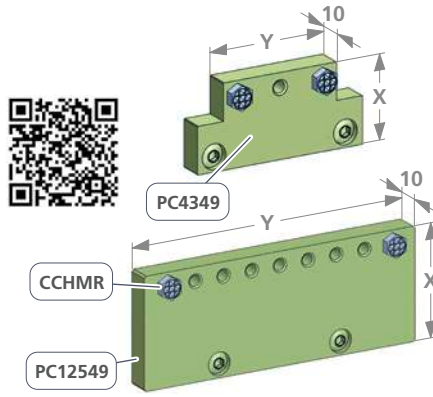

für Hartmetalldruckstücke und Fräsanschlag
for carbide grippers and milling buffer

| Art. Nr. | kg | X |
|-----------------|-------|----|
| PC4834RF | ~0,34 | 34 |
| PC4849RF | ~0,44 | 49 |
| PC9434RF | ~0,43 | 34 |
| PC9449RF | ~0,43 | 49 |

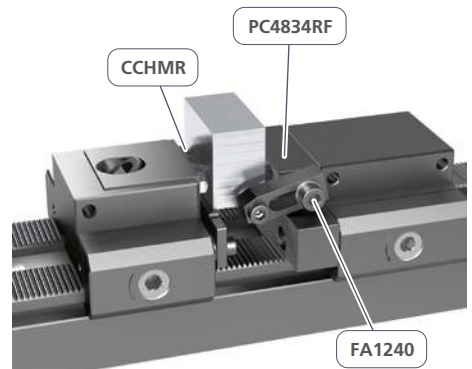
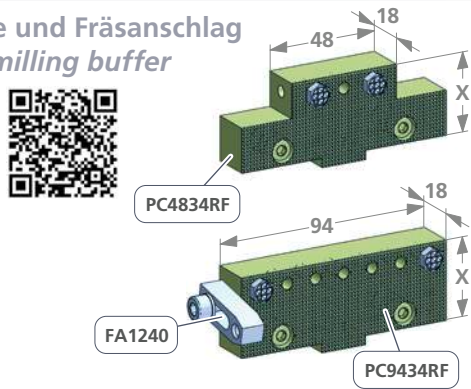

mit pendelnden Kugeldruckstücken
with swinging ball thrust grippers

| Art. Nr. | kg |
|----------------|-------|
| PC9460 | ~0,45 |
| PC9460R | ~0,45 |

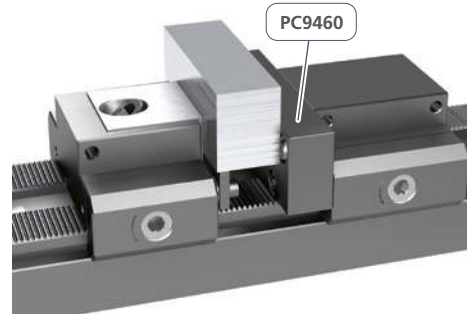
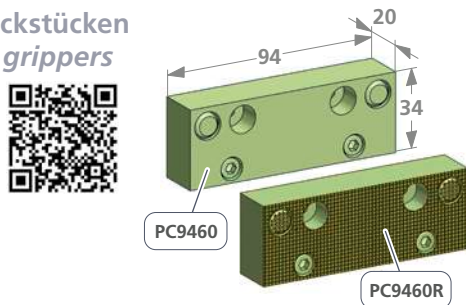

mit Prägeeinsätzen
with embossed inserts

| Art. Nr. | kg |
|-----------------------|-------|
| PC9434-25PRGM8 | ~0,64 |

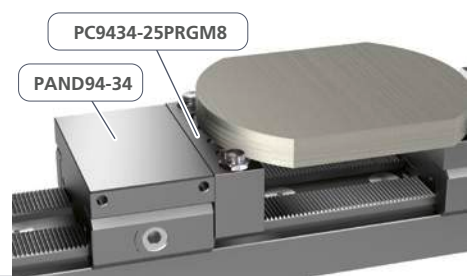
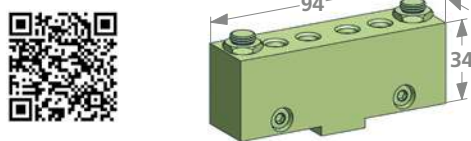

mit direkt-Prägezähnen und Spannstufen
with direct stamping teeth and clamping steps

| Art. Nr. | kg | H |
|-------------------|-------|----|
| PC48-34PRG | ~0,18 | 34 |
| PC48-49PRG | ~0,24 | 49 |
| PC94-34PRG | ~0,25 | 34 |
| PC94-49PRG | ~0,48 | 49 |
| PC4834-15 | ~0,19 | 34 |
| PC4849-15 | ~0,24 | 49 |

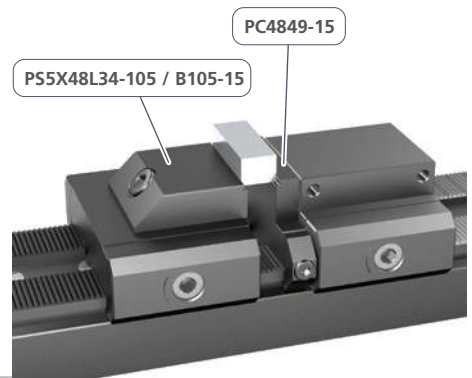
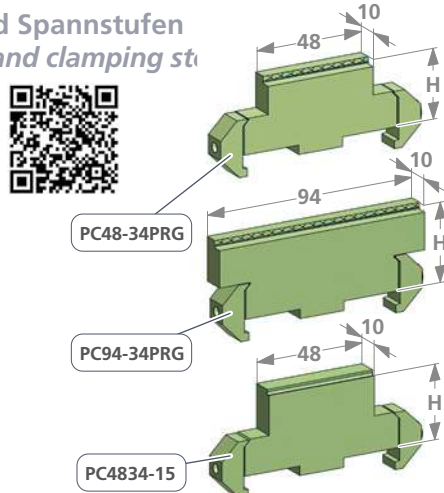

mit Druckstiften
with pressure pins

| Art. Nr. | kg | Y | X |
|------------------|-------|-----|----|
| PC4349DS | ~0,22 | 43 | 49 |
| PC4834DS | ~0,17 | 48 | 34 |
| PC4849DS | ~0,23 | 48 | 49 |
| PC9434DS | ~0,27 | 94 | 34 |
| PC9449DS | ~0,38 | 94 | 49 |
| PC12549DS | ~0,49 | 125 | 49 |



Druckstift
Pressure pin
DSE0402-60°

weitere Druckstücke
more gripping pens
p. 337

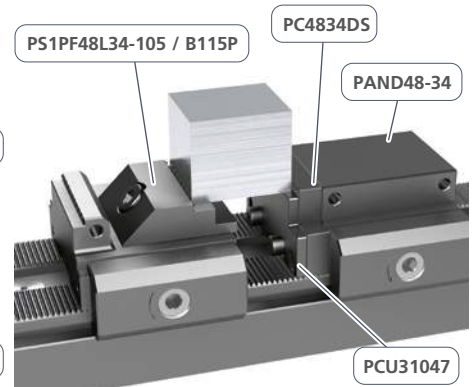
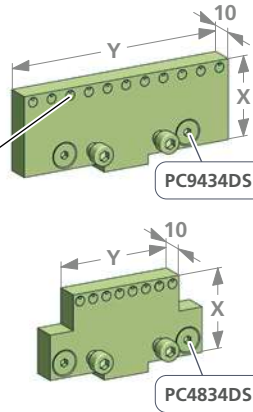

aus weichem Stahl, zur Herstellung Ihrer individuellen Backe
made of soft steel, for the production of your individual clamping jaw

| Art. Nr. | kg | Z | Y | X |
|--|-------|-----|----|----|
| PC943425W weicher Stahl soft steel (1.0570) | ~0,64 | 94 | 25 | 34 |
| PC943430W weicher Stahl soft steel (1.0570) | ~0,77 | 94 | 30 | 34 |
| PC944930W weicher Stahl soft steel (1.0570) | ~1,10 | 94 | 30 | 49 |
| PC1254930W weicher Stahl soft steel (1.0570) | ~1,46 | 125 | 30 | 49 |

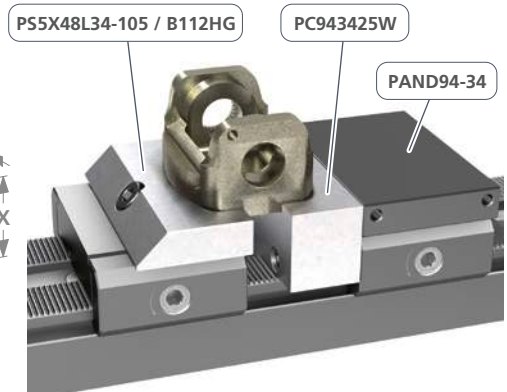
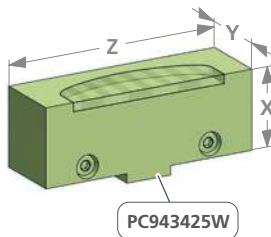

in Prismaform
in prism form

| Art. Nr. | kg | Y | X |
|--------------------|-------|----|----|
| PC9434V90-2 | ~0,58 | 28 | 34 |
| PC9449V90-2 | ~0,58 | 28 | 49 |
| PC9434V120 | ~0,62 | 35 | 34 |
| PC9449V120 | ~0,89 | 35 | 49 |

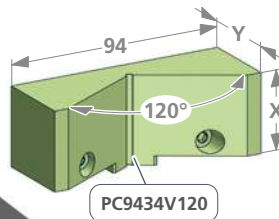
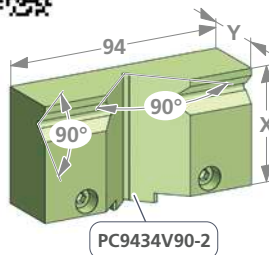

Ø
min 8
max 158
Spanndurchmesser vertikal
Clamping diameter vertical

PC9434V120

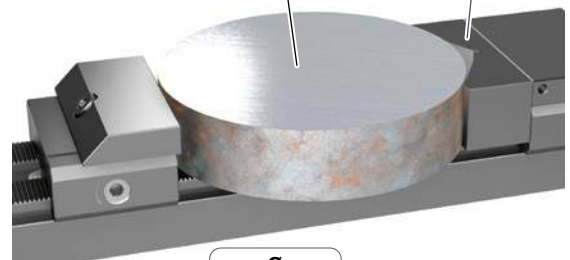

Ø
min 5
max 16
Spanndurchmesser horizontal
Clamping diameter horizontal

PC9449V90-2

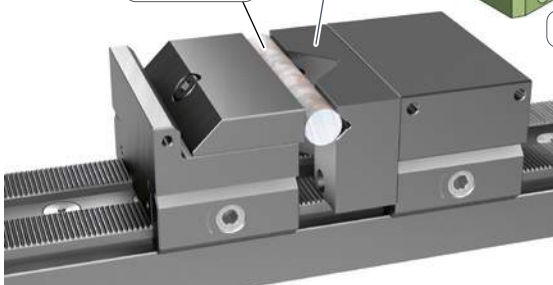

Ø
min 16
max 52
Spanndurchmesser vertikal
Clamping diameter vertical

PAND94-49

PS1F94L49-105 / B110

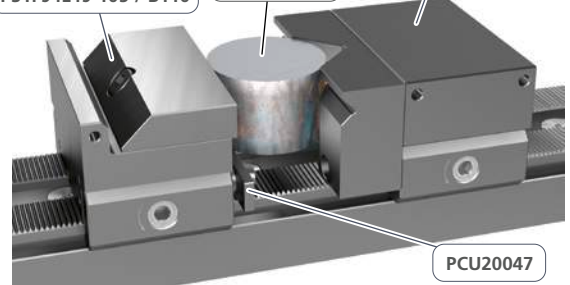

PCU20047

Von Niederzug zu Linear!
From pull down jaws to linear stroke!

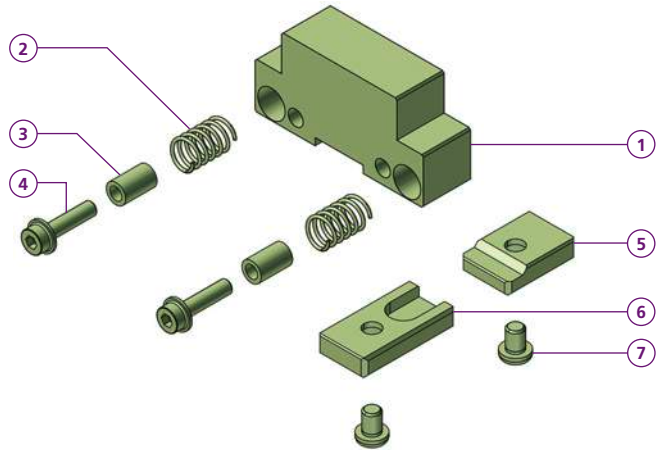
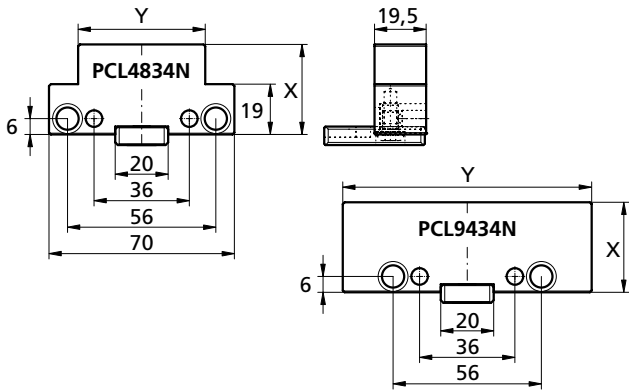

PCL4349N

- ① 1x TF140697
- ② 2x FED10175
- ③ 2x PCD0813
- ④ 2x M5X20BN1392
- ⑤ 1x PCGU2028
- ⑥ 1x PCGU2030LB
- ⑦ 2x M6X8ISO7380
- X = 49
- Y = 43
- kg ~0,43

Spannhub
Clamping stroke
 0/+3,8

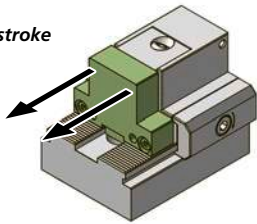

PCL4834N

- ① 1x TF140698
- ② 2x FED10175
- ③ 2x PCD0813
- ④ 2x M5X20BN1392
- ⑤ 1x PCGU2028
- ⑥ 1x PCGU2030LB
- ⑦ 2x M6X8ISO7380
- ⑧ 1x M10X22ISO4762
- X = 34
- Y = 48
- kg ~0,35

Spannhub
Clamping stroke
 0/+3,8

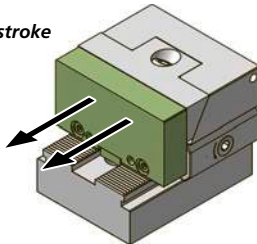

Spannhub
Clamping stroke
 0/+4,8

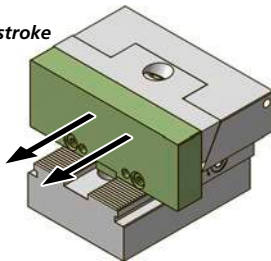

PCL9449N

- ① 1x TF140700
- X = 49
- Y = 94
- kg ~0,74

PCL12549N

- ① 1x T00317
- X = 49
- Y = 125
- kg ~0,97

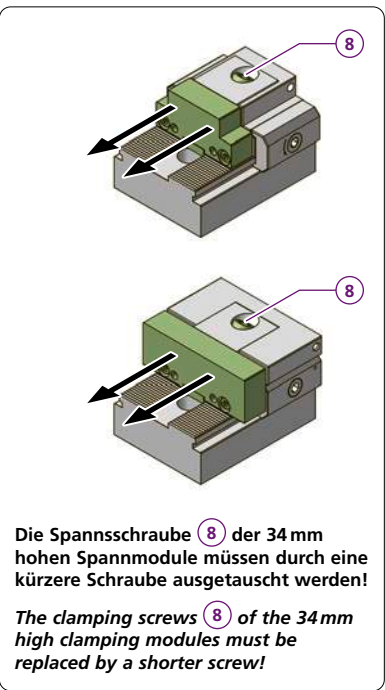

Bestellbeispiel / Ordering example: **PCL4834N**

Montagehilfe und Ersatzteile für Linearbacken
Assembling tool for linear jaws and spare parts

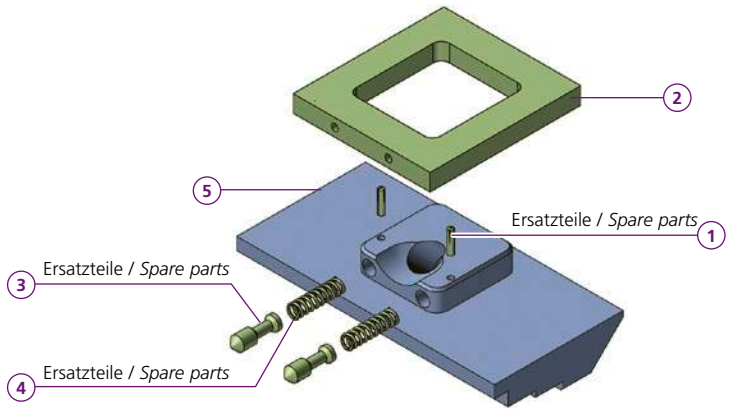
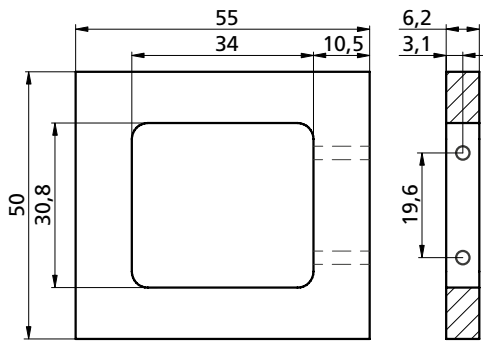

BL-SET

- ① 2x TN100823
- ② 1x TK160609
- ③ 2x PCB0516
- ④ 2x TN100614
- ⑤ 1x —————
- kg ~0,08

p. 84, 85

Alle Linearbacken
 All linear jaws

Version mit Stiften / Version with pins
 ab August / as of August 2018

Montageanleitung siehe Video
 Assembly instructions see video

Version mit Kugeln / Version with balls
 vor August / before August 2018



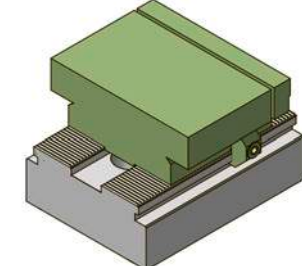
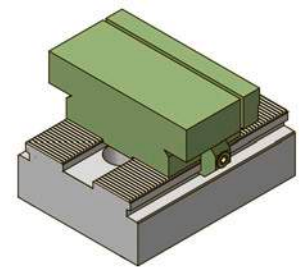
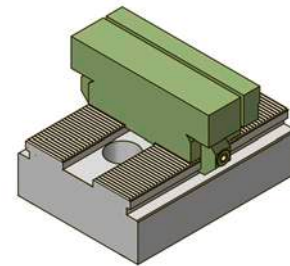
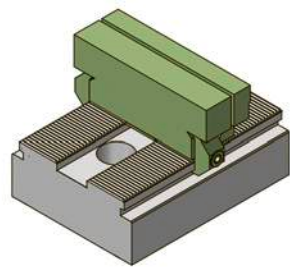
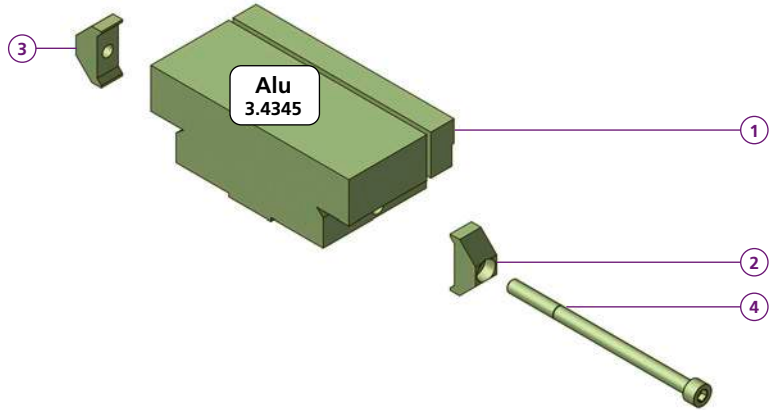
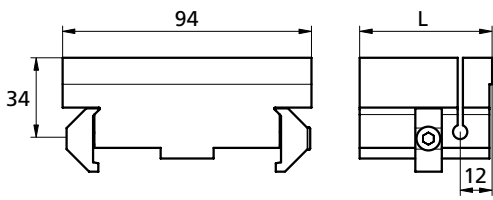

- PCFX30**
- ① 1x TF140702
 - ② 1x PCSP10B
 - ③ 1x PCSP10G
 - ④ 1x M5X85ISO4762
- L = 30
kg ~0,27

- PCFX35**
- ① 1x TF140703
- L = 35
kg ~0,31

- PCFX50**
- ① 1x TF140704
 - ② 1x PCSP10B
 - ③ 1x PCSP10G
 - ④ 1x M5X85ISO4762
- L = 50
kg ~0,45

- PCFX70**
- ① 1x TF140705
- L = 70
kg ~0,62

Auf Anfrage in Stahl erhältlich
On request also in steel

Bestellbeispiel / Ordering example: PCFX30

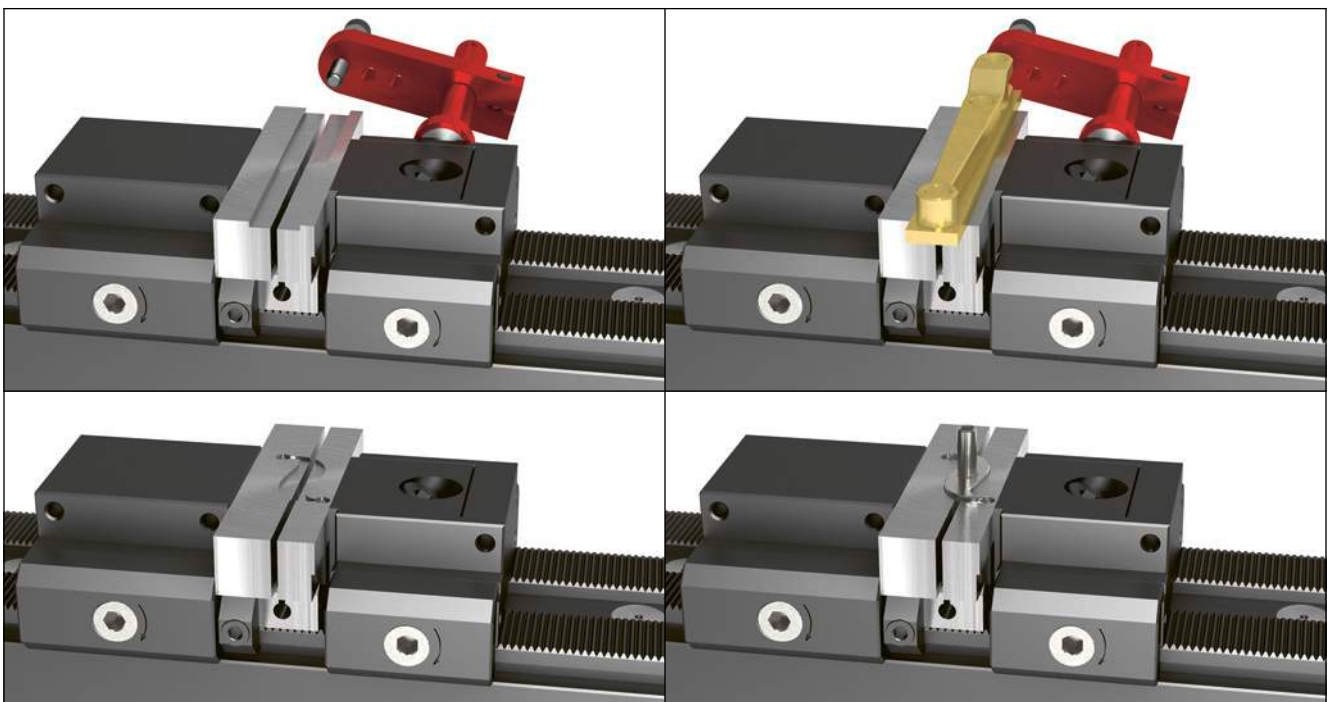

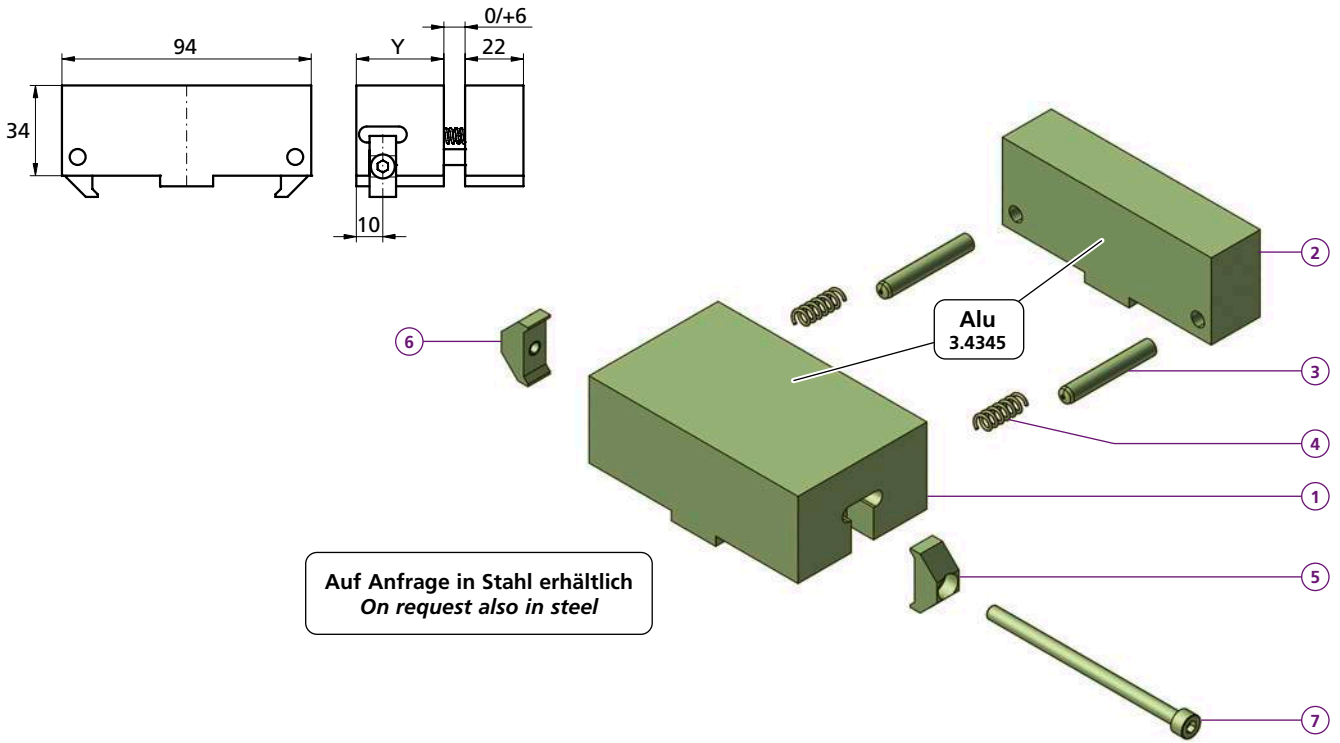

Auf Anfrage in Stahl erhältlich
On request also in steel

PCFM3322

- ① 1x PCFM33
- ② 1x PCFF22
- ③ 2x CCBO0801
- ④ 2x FED0618
- ⑤ 1x PCSP10B
- ⑥ 1x PCSP10G
- ⑦ 1x M5X85ISO4762

Y = 33
kg ~0,52

PCFM5822

- ① 1x PCFM58

Y = 58
kg ~0,75

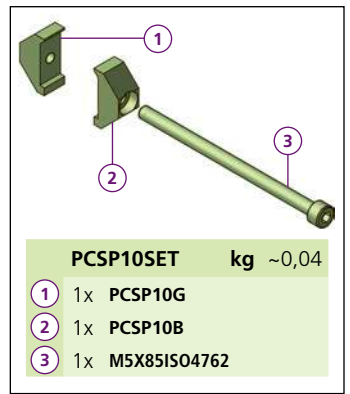
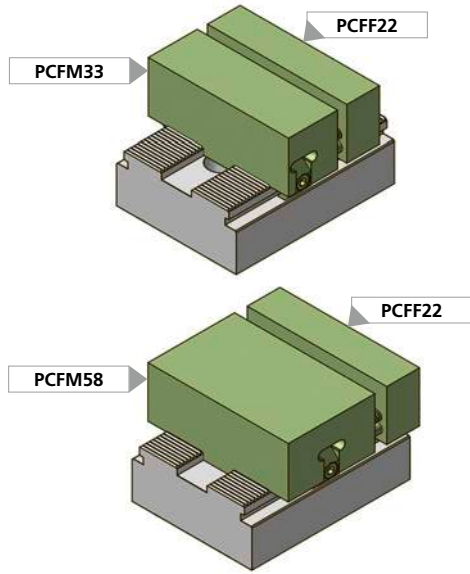

Bestellbeispiel / Ordering example: **PCFM3322**

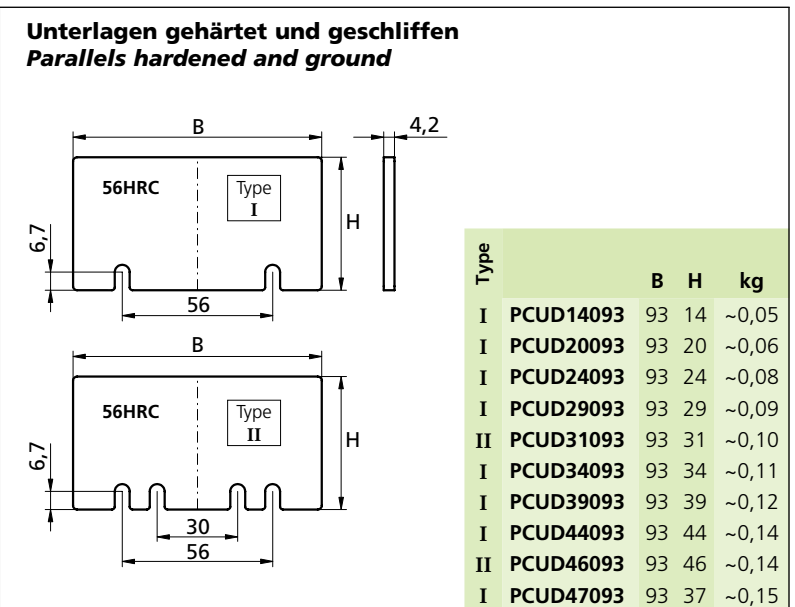
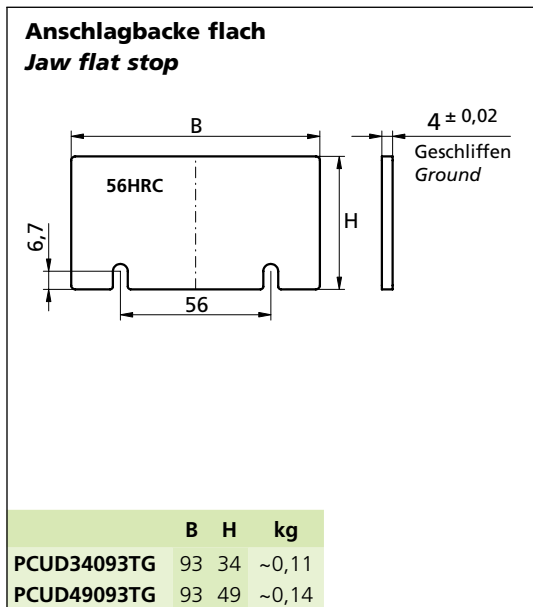

Niederzugbacken für die Anschlagseite
Pull-down jaws for the solid reference fase

| Art. Nr. | kg | H | Z |
|------------------|-------|-----------|------------|
| PC9434NVB | ~0,24 | 49,8 – 49 | 10,21 – 10 |
| PC9449NVB | ~0,35 | 34,8 – 34 | 10,21 – 10 |

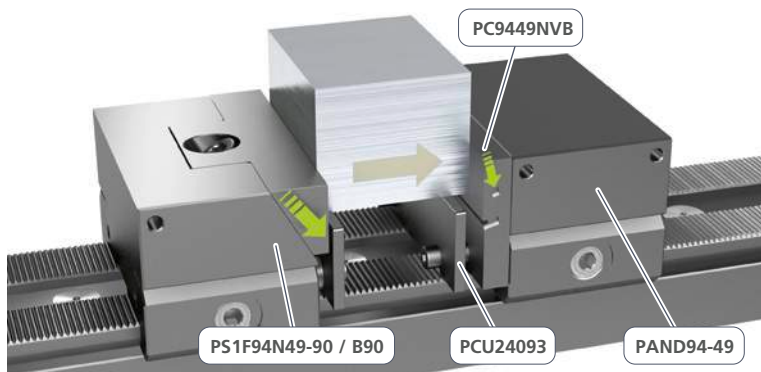
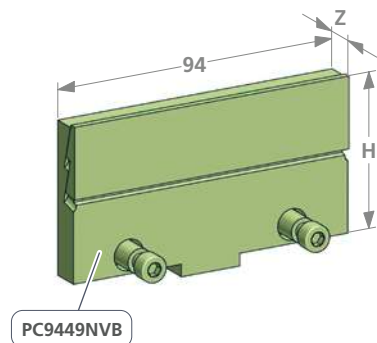

Die Niederzugbacke dient um einen zusätzlichen Niederzug-Klemmdruck auf der Anschlagseite zu erhalten.

The pull-down jaw is used to obtain an additional pull-down clamping pressure on the end module side.

Magnetische Parallelunterlagen
Magnetic steel parallels

| Art. Nr. | kg | H |
|--------------------|-------|----|
| PCUM1409308 | ~0,09 | 14 |
| PCUM2009308 | ~0,13 | 20 |
| PCUM2409308 | ~0,15 | 24 |
| PCUM2909308 | ~0,18 | 29 |
| PCUM3109308 | ~0,20 | 31 |
| PCUM3409308 | ~0,21 | 34 |
| PCUM3909308 | ~0,24 | 39 |
| PCUM4409308 | ~0,27 | 44 |
| PCUM4609308 | ~0,28 | 46 |

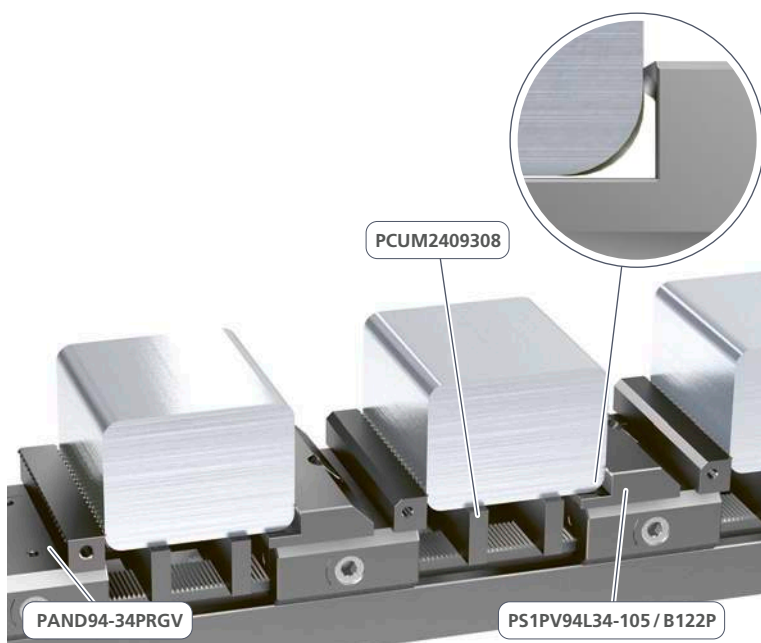
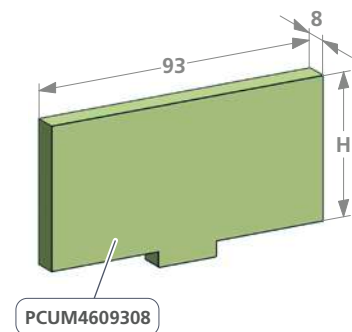

Mit diesen magnetischen Parallelunterlagen ist die Positionierung auf der Basisschiene frei wählbar. Bei Werkstücken mit grösseren Rundungen sind die Spannbacken B122P / B123P zusammen mit den Anschlagmodulen PAND94-34PRGV / PAND94-49PRGV bestens geeignet.

With these magnetic steel parallels, the positioning on the base rail is freely selectable. For workpieces with larger curves, the clamping jaws B122P / B123P together with the end modules PAND94-34PRGV / PAND94-49PRGV are best suited.



triCENTRO

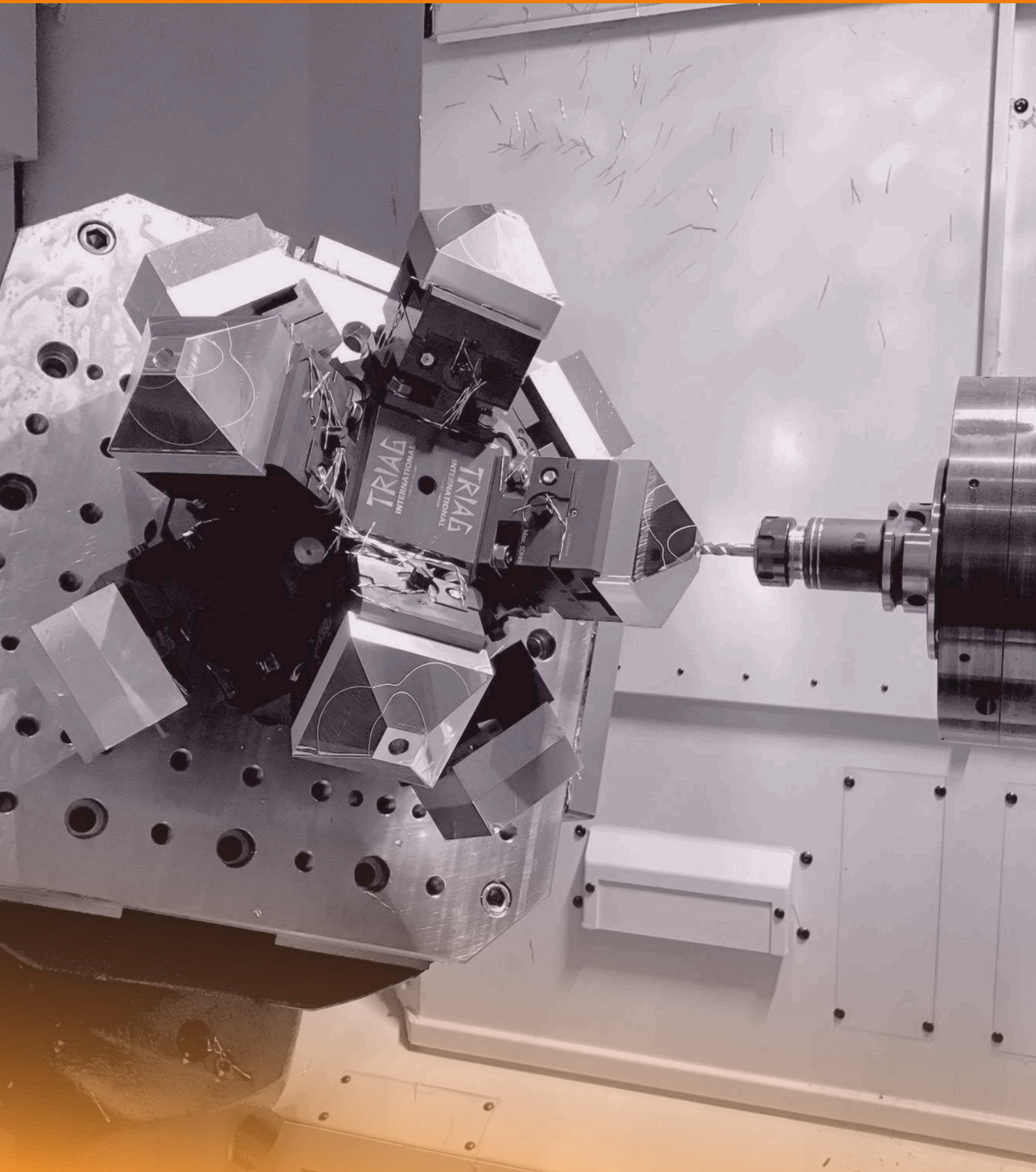



Einleitung und Anwendungsbeispiele | *Introduction and examples of application* 115

Micro - Zentrierspanner | *Micro - self centering vise* 116 - 117

5-Achs Pyramidenlösungen
5-axis pyramid solutions 35° 118

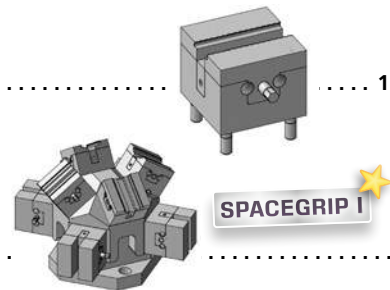

5-Achs Pyramidenlösungen
5-axis pyramid solutions 45° 119



5-Achs Pyramidenlösungen
5-axis pyramid solutions 20° 122



Kompakter Zentrischspanner | *Compact self centering vise* 123 - 124

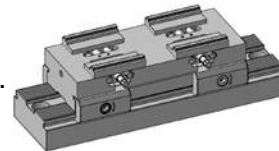

Mini Zentrierspanner | *Mini - self centering vise* 126 - 129

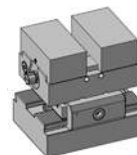

Zentrischspanner mit Anschlagbrücke
Self centering vise with center stop 130 - 131



Mini Zentrischspanner / Spannvielfalt der Backen | *Mini - self centering vise / Clamping variety of jaws* 132

5-Achs Pyramidenlösungen
5-axis pyramid solutions 45° / 90° 133

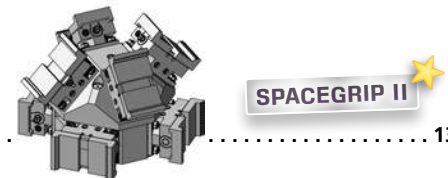

5-Achs Pyramidenlösungen
5-axis pyramid solutions 45° 136



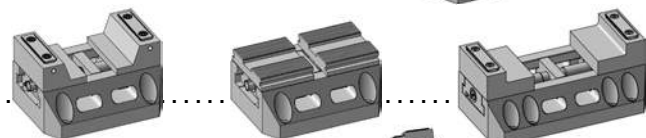

Zentrischspanner X M Q Serien
Self centering vises X M Q series 137 - 149

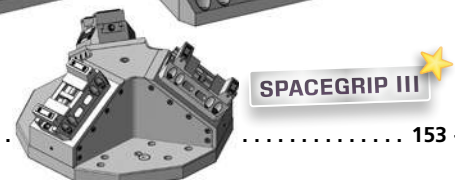

5-Achs Pyramidenlösungen
5-axis pyramid solutions 35°-3 153 - 154

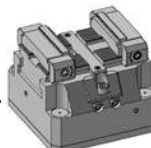

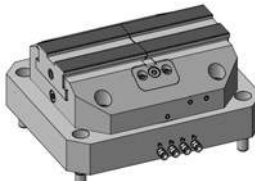
| | | |
|--|---|-----------------|
| ZSP Micro - Zentrischspanner ZSP Micro - self centering vise |  | 156 |
| ZSP125 Mini - Pneumatischer Zentrischspanner (einfacher Kolben) ZSP125 Mini - Pneumatic self centering vise (single piston) |  | 157 |
| ZSP125 Mini - Pneumatischer Zentrischspanner (Doppelkolben) ZSP125 Mini - Pneumatic self centering vise (Double piston) |  | 158 |
| ZSP Grande - Pneumatischer Zentrierspanner ZSP Grande - Pneumatic self centering vise |  | 160 - 161 |

Triag International AG bietet ein breites Sortiment an Zentrischspannern an. Neben den Zentrischspannern, die auf die Schienensysteme Power Clamp das Nullpunktsystem oppSystem passen, sind auch Ausführungen für Lochraster erhältlich.

Mit unseren modularen Zentrischspannblöcken bieten wir eine optimale Lösung für die Mehrfachspannung in Ihrer 5-Achs Fräsmaschine an. Für alle Zentrischspanner sind verschiedene Aufsatz- und Prägebacken erhältlich.

Triag International AG offers a wide range of self centering vices. In addition to the self centering vice that fit into the rail systems Power Clamp the zero point system oppSystem, mechanical self centering vice are also available.

With our modular self centric vice blocks we offer an optimal solution for multiple workholding in your 5-axis milling machine. Different jaws and stamping jaws are available for all self centering vices.

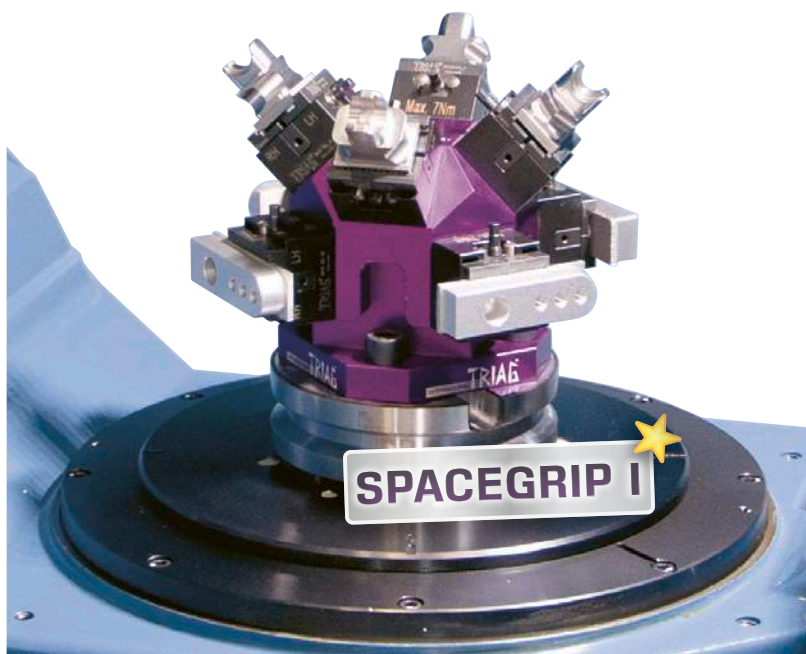
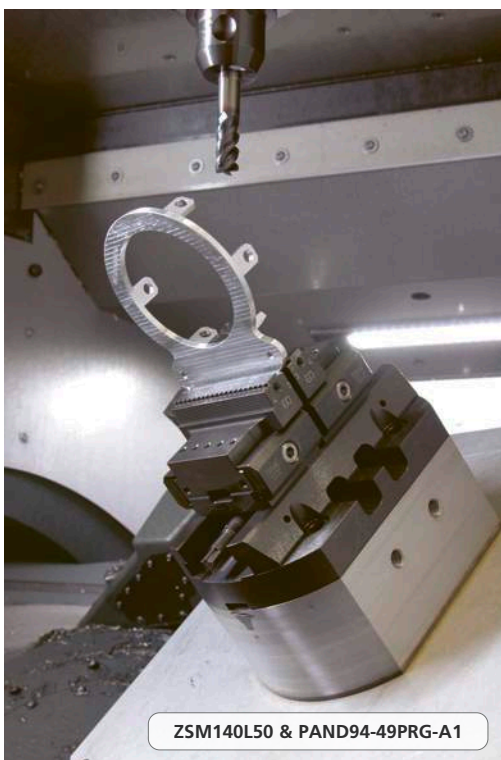

Für den Vorrichtungsbau
For dedicated fixtures

| Art. Nr. | i | | A mm | kg |
|----------------------|---|--|--------------------------------------|----------------|
| MCZ40L30PRG13 | | | 3 – 13 | ~0,34 |
| MCZ40L30PRG22 | | | 12 – 22 | ~0,33 |
| MCZ40L30PRG31 | | | 21 – 31 | ~0,32 |
| MCZ40L30W6 | | | weicher Stahl soft steel (1.7225) | variabel ~0,33 |
| MCZ40L30W10 | | | weicher Stahl soft steel (1.7225) | variabel ~0,37 |
| MCZ40L30W20 | | | weicher Stahl soft steel (1.7225) | variabel ~0,47 |
| MCZ40L30W30 | | | weicher Stahl soft steel (1.7225) | variabel ~0,57 |

NUSS 1/4" 4.5MM

WICHTIG!
Bitte separat bestellen
IMPORTANT!
Please order separately

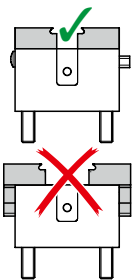

ACHTUNG / CAUTION

Die Angaben der Spannereiche bei den verschiedenen Backen sind unbedingt zu beachten und einzuhalten! Bei unsachgemäßer Anwendung übernimmt TRIAG International keine Haftung.

The details of the clamping ranges for the different jaws must be strictly followed! In case of improper use, TRIAG International assumes no liability.

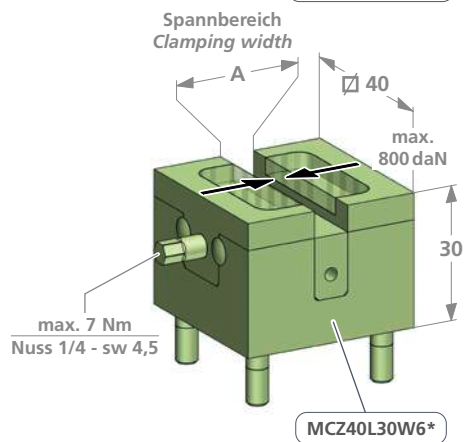
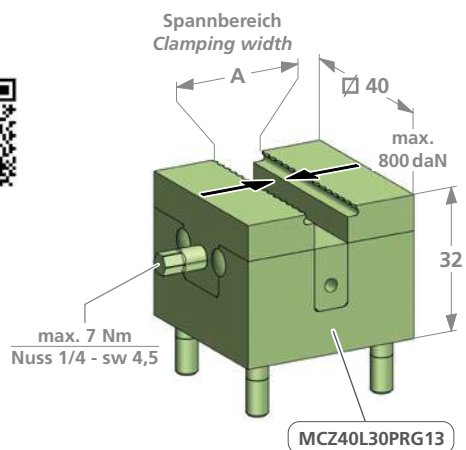

z.B. Fräsanschlag / f.e. Milling buffer



| Art. Nr. | B190-13 | B190-22 | B190-31 |
|----------|----------------|----------------|----------------|
| i | 57HRC | 57HRC | 57HRC |
| kg | ~0,09 | ~0,08 | ~0,08 |
| | | | |

Für den Vorrichtungsbau / Mit einstellbarem Mittellager
For dedicated fixtures / With adjustable center position

| Art. Nr. | Backen Jaws | A mm | kg |
|------------------|-------------------|----------|-------|
| MCZ40L30E | B190-13 | 3 – 13 | ~0,24 |
| | B190-22 | 12 – 22 | |
| | B190-31 | 21 – 31 | |
| | B190W6-40 | variabel | |
| | B190W10-40 | variabel | |
| | B190W20-40 | variabel | |
| | B190W30-40 | variabel | |

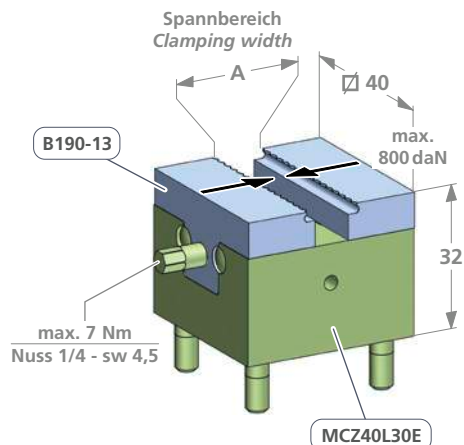

Das Zentrum kann durch das Mittellager um +/- 0,5 mm
verstellt werden. Eine schwimmende
Werkstückspannung ist auch möglich.

Lieferzustand:

Zentriert mit einer Toleranz von +/- 0,03 mm

The center can be adjusted by +/- 0,5 mm through the center
support. A floating fixture is also possible.

Delivery condition:

Centered with a tolerance of +/- 0,03 mm

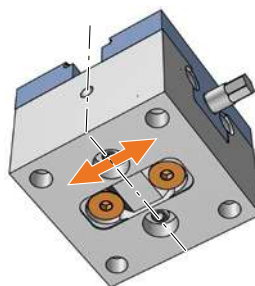

Bedienungsanleitung
Operating instruction



Ohne einstellbares Mittellager
Without adjustable center position

| Art. Nr. | Backen Jaws | A mm | kg |
|-----------------|-------------------|----------|-------|
| MCZ40L30 | B190-13 | 3 – 13 | ~0,24 |
| | B190-22 | 12 – 22 | |
| | B190-31 | 21 – 31 | |
| | B190W6-40 | variabel | |
| | B190W10-40 | variabel | |
| | B190W20-40 | variabel | |
| | B190W30-40 | variabel | |

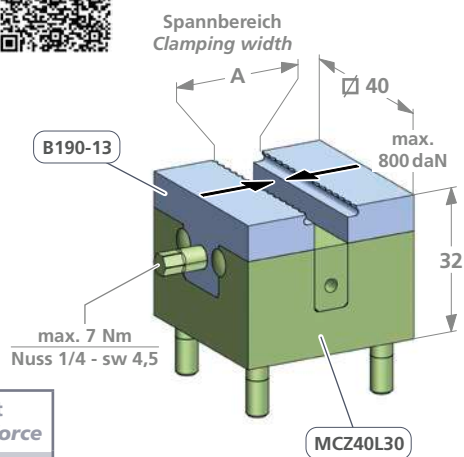

| Drehmoment Torque | | Spannkraft Workholding force | | |
|----------------------|---------|---------------------------------|-------|------|
| Nm | (lb-ft) | ~daN | ~(lb) | ~t |
| 4 | 3 | = 457 | 1'007 | 0,46 |
| 5 | 3,7 | = 571 | 1'259 | 0,57 |
| 6 | 4,4 | = 686 | 1'512 | 0,69 |
| 7 | 5,2 | = 800 | 1'764 | 0,8 |

| B190W6-40 | B190W10-40 | B190W20-40 | B190W30-40 |
|--------------------------------------|--------------------------------------|--------------------------------------|--------------------------------------|
| weicher Stahl soft steel (1.7225) | weicher Stahl soft steel (1.7225) | weicher Stahl soft steel (1.7225) | weicher Stahl soft steel (1.7225) |
| ~0,08 | ~0,012 | ~0,22 | ~0,32 |
| | | | |

Weich, zur Herstellung individueller Formbacke. / Soft, for the production of individual moulding jaw.



SEPARAT BESTELLEN
ORDER SEPARATELY

spaceGRIP I

Die spaceGRIP Baureihe wurde speziell für die effizientere Nutzung von 5-Achsen Maschinen entwickelt. Dabei zeichnen sich alle drei Baureihen der spaceGRIP Serie mit unterschiedlichen Merkmalen aus.

Sehr kompakte Bauweise zur Aufnahme von 4 oder 8 Micro Zentrischspannmodulen. Für die Rohteilebearbeitung gibt es drei Bausätze Prägebacken (3-13 mm, 12-22 mm und 21-31 mm).

Für die zweite Spannung gibt es vier Sätze unterschiedlicher Backenrohlinge für die Einarbeitung einer Kontur. Die Spannkraft liegt bei 7 Nm 0,8t 800 daN.

spaceGRIP I

The spaceGRIP series was specially developed to improve the out puts of 5-axis machines. All three types of the spaceGRIP series have different features.

Very compact design to hold 4 or 8 micro self centering clamping modules. There are three assembly kits of stamping jaws (3-13 mm, 12-22 mm and 21-31 mm) for raw part machining.

For the second clamping, there are four sets of different jaw blanks to integrate any shapes. The clamping force is at 7 Nm 0.8t 800 daN.

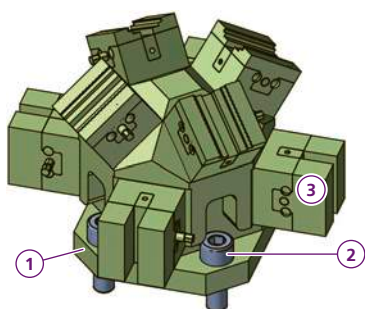
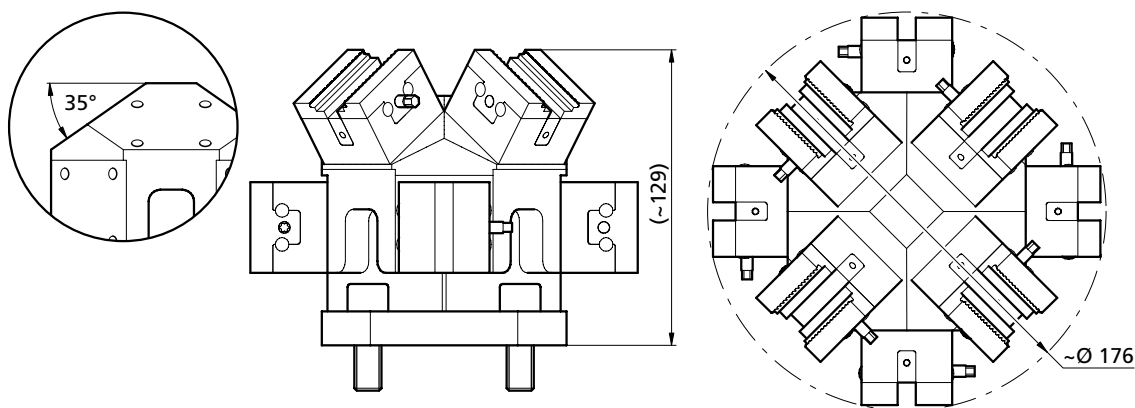

- UB5AXMCZ4035SET8**
- 1** 1x TB170676
- 2** 4x M12X35ISO4762
- 3** 8x Ihre Wahl/ Your choice p. 116 - 117
- kg ~5,1



Detailzeichnung zu dieser Schnittstelle
Detail drawing to interface

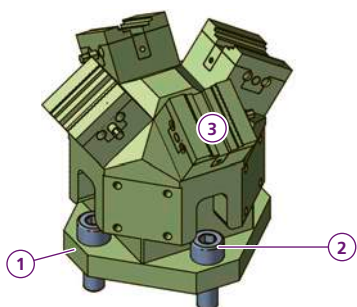

- UB5AXMCZ4035SET4**
- 1** 1x TB170676
- 2** 4x M12X35ISO4762
- 3** 4x Ihre Wahl/ Your choice p. 116 - 117
- kg ~3,2



Detailzeichnung zu dieser Schnittstelle
Detail drawing to interface

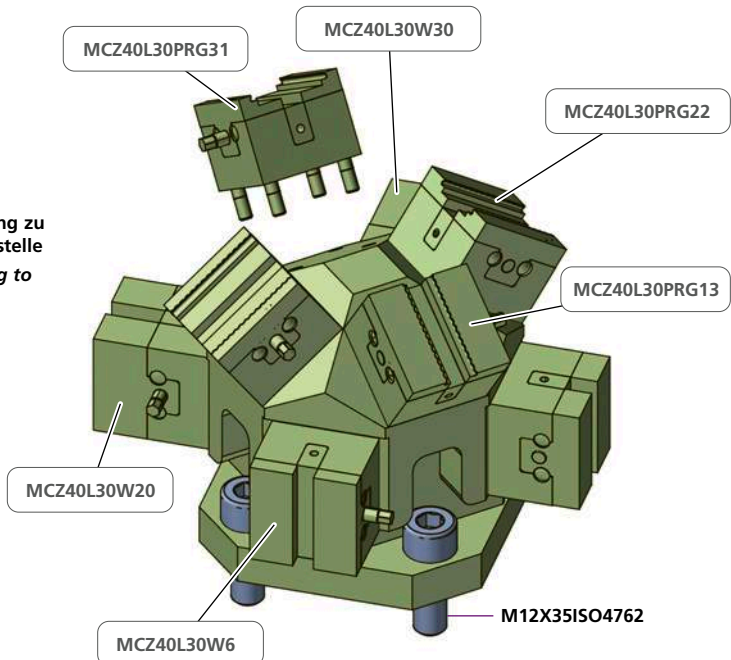

NUSS 1/4" 4.5MM

WICHTIG!
Bitte separat bestellen

IMPORTANT!
Please order separately

Bestellbeispiel / Ordering example:
2 x UB5AXMCZ40-35SET8 & 8 x MCZ40L30W10 &
8 x MCZ40L30PRG22 & 1 x Nuss 1/4 - sw 4,5

Separat bestellen / Order separately

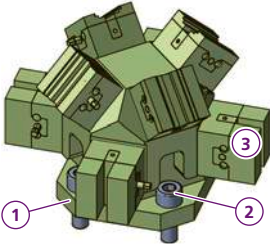

- UB5AXMCZ40-45SET8**
- 1x TK140867
 - 4x M12X35ISO4762
 - 8x Ihre Wahl/ Your choice
- kg ~5,2



Detailzeichnung zu dieser Schnittstelle
Detail drawing to interface

p. 116 - 117

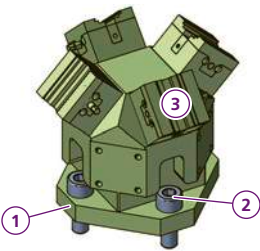
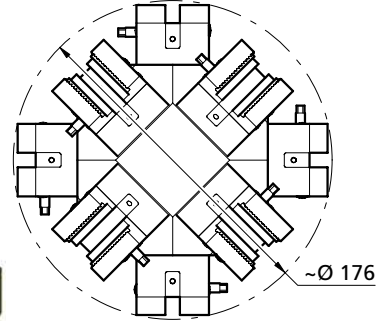
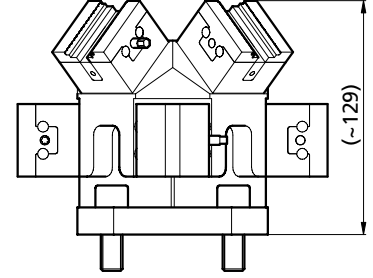
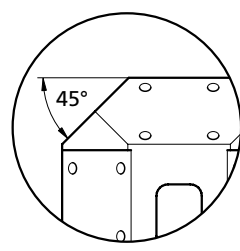

- UB5AXMCZ4045SET4**
- 1x TK140867
 - 4x M12X35ISO4762
 - 4x Ihre Wahl/ Your choice
- kg ~4,2



Detailzeichnung zu dieser Schnittstelle
Detail drawing to interface

p. 116 - 117

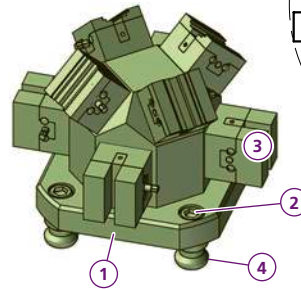

- UB5AXMCZ4045SET8-OPBM**
- 1x TK160869
 - 4x M12X20ISO4762
 - 8x Ihre Wahl/ Your choice
 - 4x OPBM18M12
- kg ~6,2



Detailzeichnung zu dieser Schnittstelle
Detail drawing to interface

p. 116 - 117

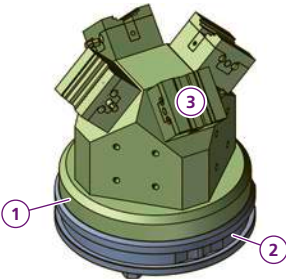

- UB5AXMCZ4045SET4-ER**
- 1x TB161062
 - 1x ER041912 EROWA ITS-Palette
 - 4x Ihre Wahl/ Your choice
- kg ~4,1



Detailzeichnung zu dieser Schnittstelle
Detail drawing to interface

p. 116 - 117

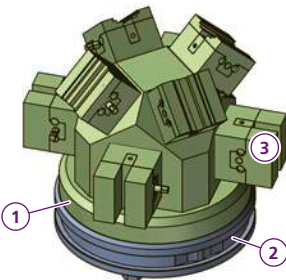

- UB5AXMCZ40-45SET8-ER**
- 1x TB161062
 - 1x ER041912 EROWA ITS-Palette
 - 8x Ihre Wahl/ Your choice
- kg ~6,1



Detailzeichnung zu dieser Schnittstelle
Detail drawing to interface

p. 116 - 117

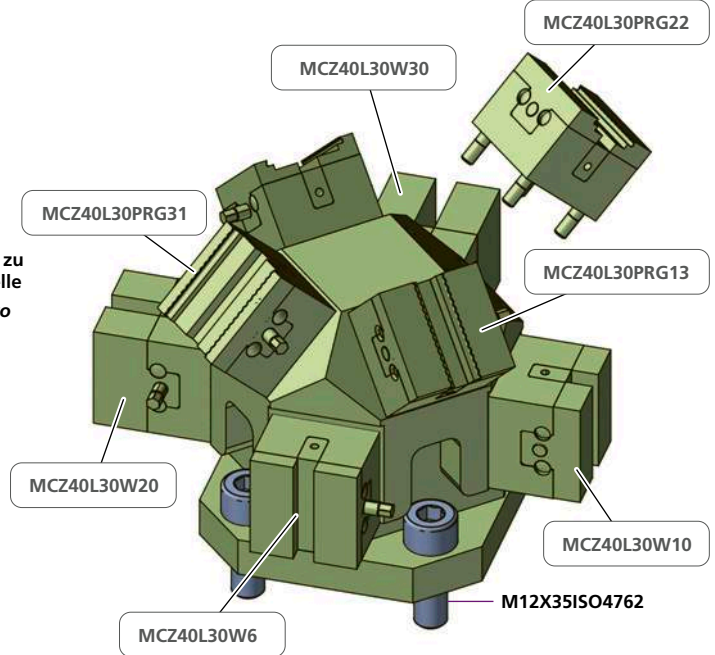

NUSS 1/4" 4.5MM

WICHTIG!
Bitte separat bestellen
IMPORTANT!
Please order separately



Bestellbeispiel / Ordering example:
2 x UB5AXMCZ40-45SET8 & 8 x MCZ40L30W20 & 8 x MCZ40L30PRG22 & 1 x Nuss 1/4 - sw 4,5

Separat bestellen / Order separately

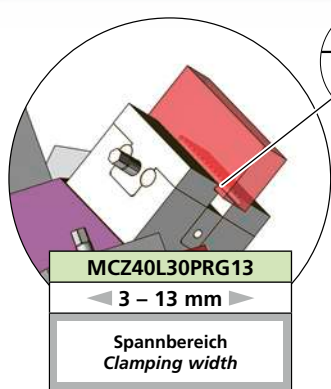

MCZ40L30PRG13

◀ 3 – 13 mm ▶

Spannbereich
Clamping width

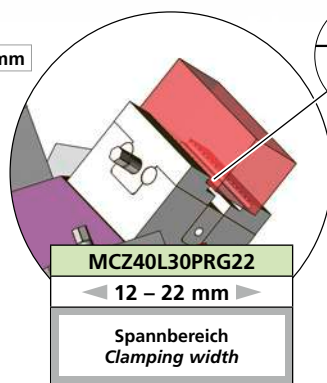
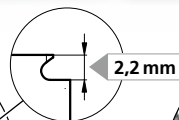

MCZ40L30PRG22

◀ 12 – 22 mm ▶

Spannbereich
Clamping width

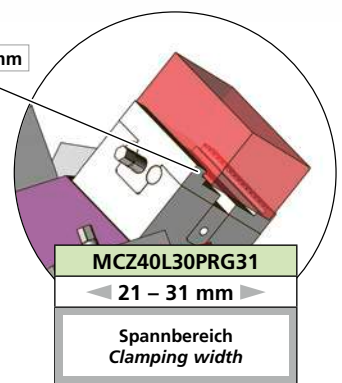
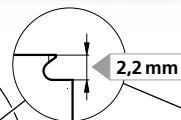

MCZ40L30PRG31

◀ 21 – 31 mm ▶

Spannbereich
Clamping width

p. 116 Micro Zentrischspanner / Micro - self centering vise



MCZ40L30W6

Zum Erstellen Ihrer individuellen Formbacke
If a dedicated jaw is being machined



MCZ40L30W10

Zum Erstellen Ihrer individuellen Formbacke
If a dedicated jaw is being machined

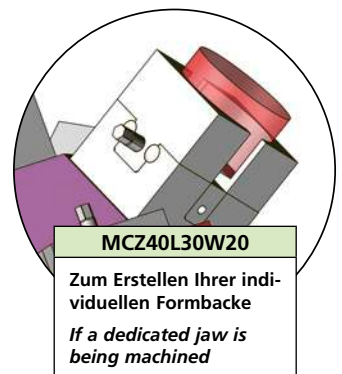

MCZ40L30W20

Zum Erstellen Ihrer individuellen Formbacke
If a dedicated jaw is being machined

p. 116 Micro Zentrischspanner / Micro - self centering vise

Anwendungsbilder
Pictures of application to

MICRO

Zentrischspanner
self centering vise

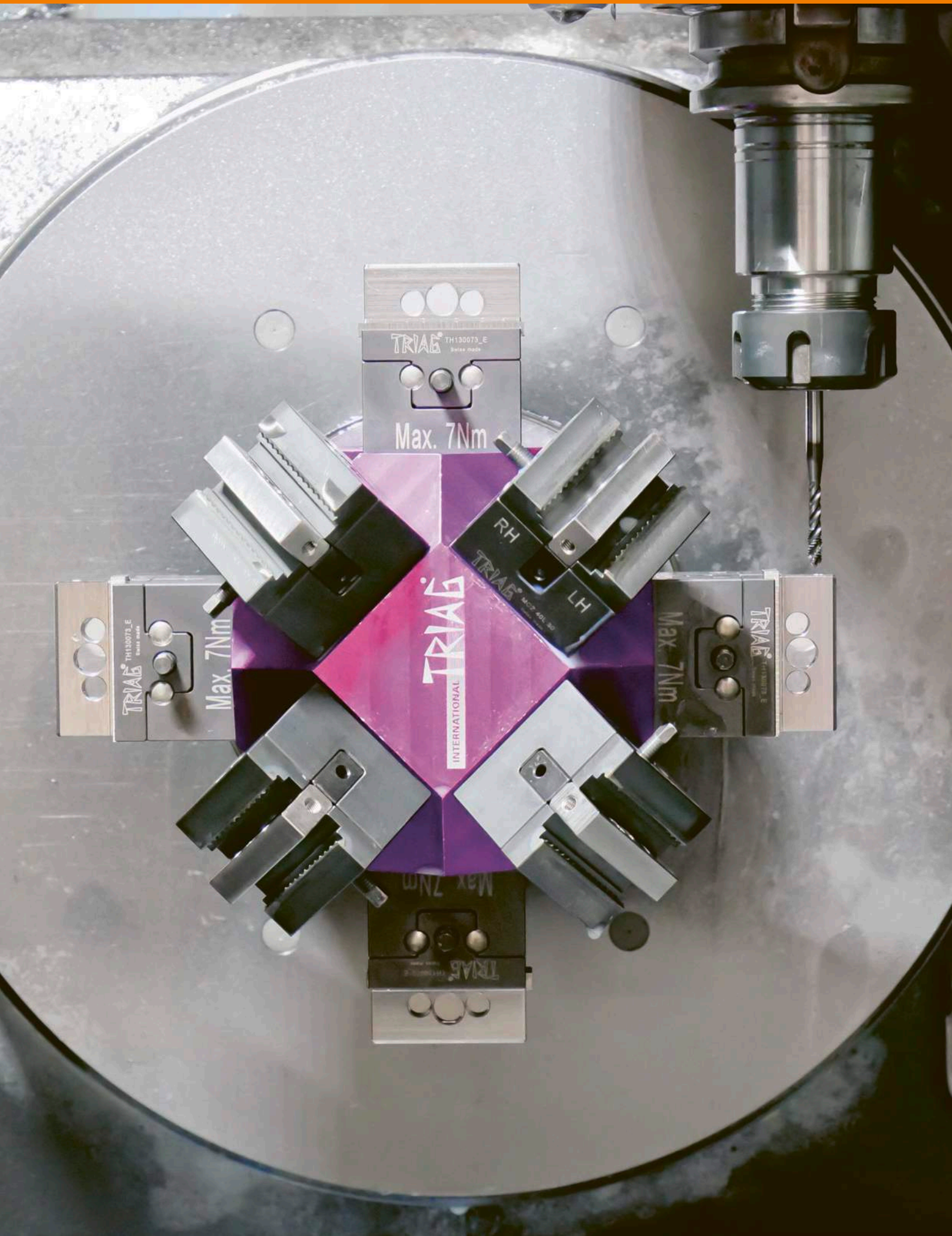

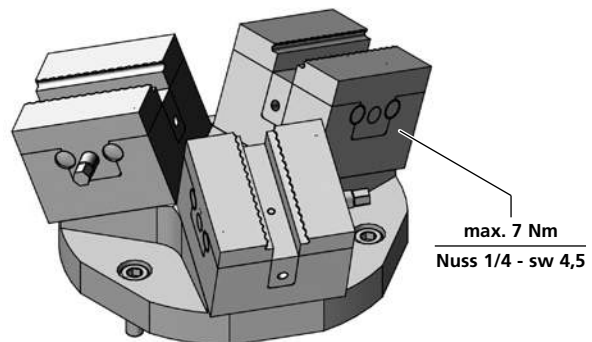
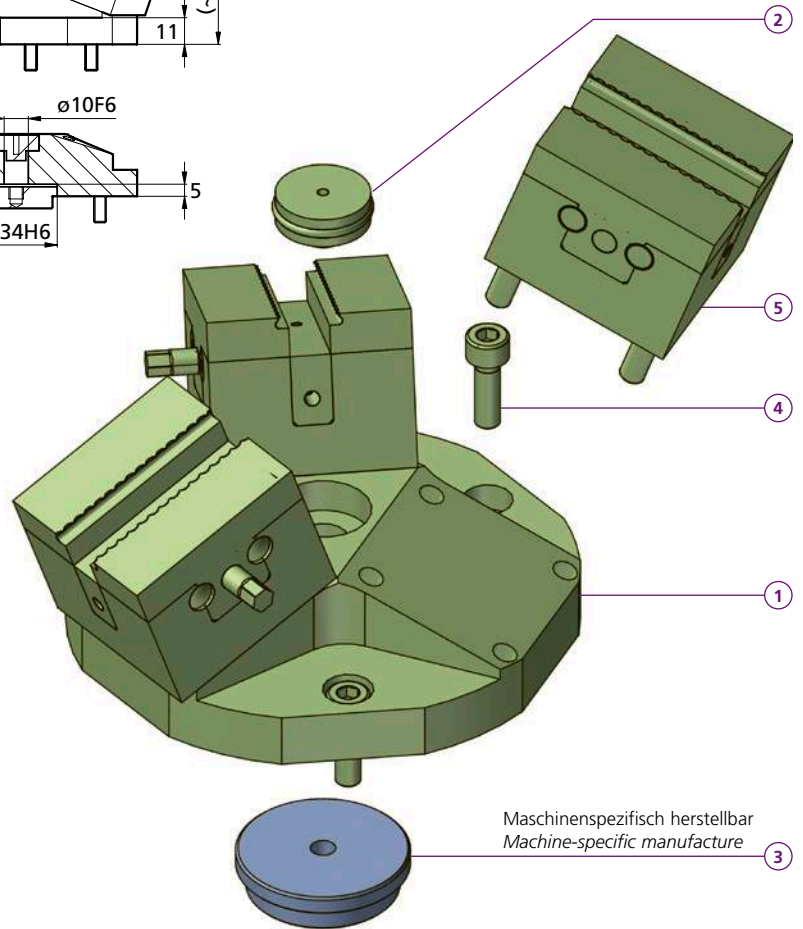
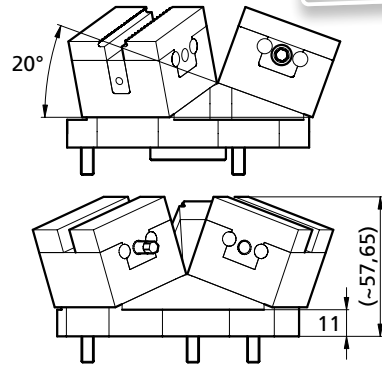
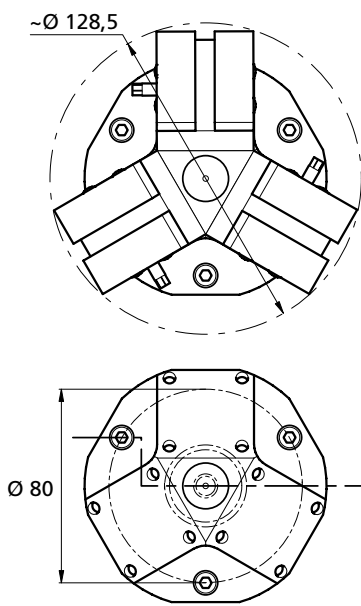

20° UB5AXSET18-3

- 1 1x TH170934
- 2 1x PCPF16L6
- 3 1x TH171176
- 4 3x M5X16ISO4762
- 5 3x Ihre Wahl / Your choice

p. 116 - 117

kg ~1,45

Drehmoment und Spannkraft siehe Seite
Torque and clamping force see page

117

NUSS 1/4" 4.5MM

WICHTIG!
Bitte separat bestellen
IMPORTANT!
Please order separately



Bestellbeispiel / Ordering example : 1 x UB5AXSET18-3 & 1x TH171176 & 3x M5x16

Kompakter Zentrischspanner Compact self centering vise

triCENTRO

| Art. Nr. | Backen Jaws | A mm | B mm | kg |
|----------------------|----------------|----------|----------|-------|
| PCZ80L40PRG62 | B210-26 | 32 – 62 | 6 – 35 | ~1,71 |
| | B210W11-60 | variabel | variabel | |
| | B210W20-60 | variabel | variabel | |

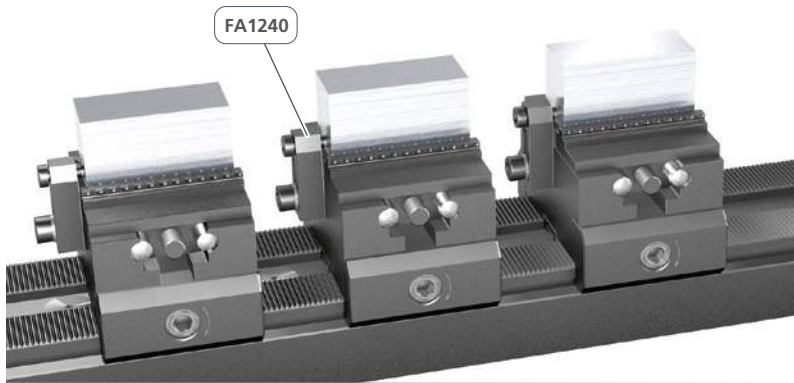
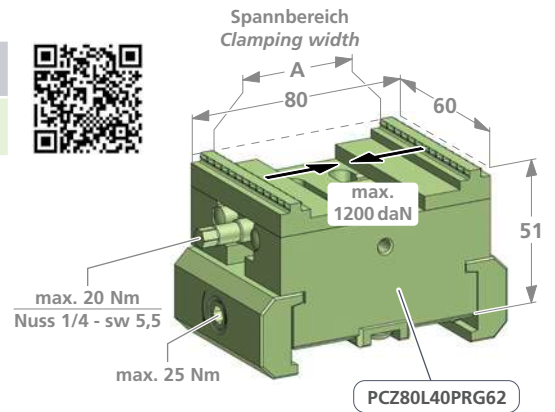

| Drehmoment Torque | | Spannkraft Workholding force | | |
|----------------------|---------|---------------------------------|-------|------|
| Nm | (lb-ft) | ~daN | ~(lb) | ~t |
| 5 | 3,7 | = 410 | 900 | 0,41 |
| 10 | 7,4 | = 830 | 1'830 | 0,83 |
| 15 | 11,0 | = 1'250 | 2'760 | 1,25 |
| 20 | 14,8 | = 1'200 | 2'645 | 1,20 |

Für den Vorrichtungsbau
For dedicated fixtures

| Art. Nr. | Backen Jaws | A mm | B mm | kg |
|----------------------|----------------|----------|----------|-------|
| MCZ80L32PRG62 | B210-26 | 32 – 62 | 6 – 35 | ~1,39 |
| | B210W11-60 | variabel | variabel | |
| | B210W20-60 | variabel | variabel | |

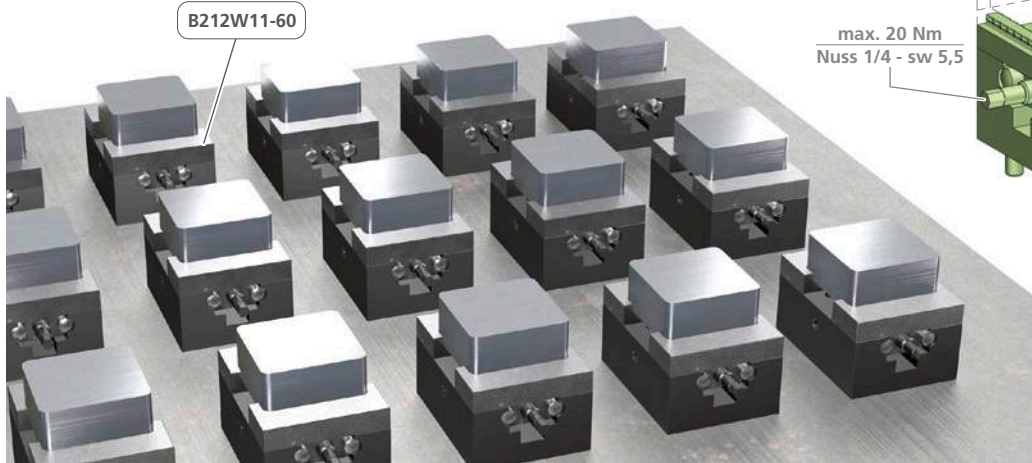
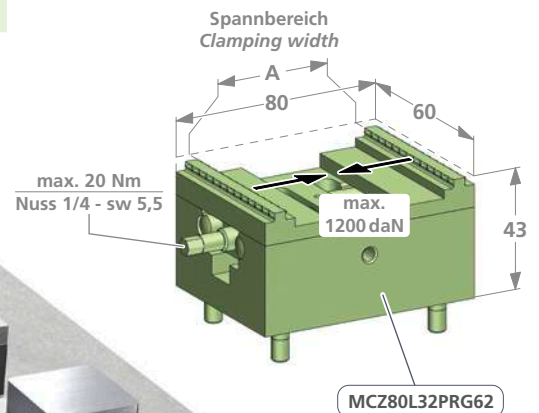

Linear- Spannbacke / Linear clamping jaw

| Art. Nr. | B210-62 | B212W11-60 | B212W20-60 |
|-----------|---------|---|---|
| i | 57HRC | Vergütungsstahl Tempering steel (1.7225) | Vergütungsstahl Tempering steel (1.7225) |
| kg | ~0,31 | ~0,31 | ~0,52 |
| | | | |

Weich, zur Herstellung individueller Formbacke. / Soft, for the production of individual moulding jaw.

NUSS 1/4" 5.5MM

WICHTIG!
Bitte separat bestellen
IMPORTANT!
Please order separately



**SEPARAT BESTELLEN
ORDER SEPARATELY**

Kompakter doppelter Zentrischspanner Compact double self centering vise

triCENTRO

| Art. Nr. | Backen Jaws | A mm | B mm | kg |
|-----------------------|----------------|----------|----------|------|
| PC2Z80L40PRG62 | B210-26 | 32 – 62 | 6 – 35 | ~4,7 |
| | B210W11-60 | variabel | variabel | |
| | B210W20-60 | variabel | variabel | |

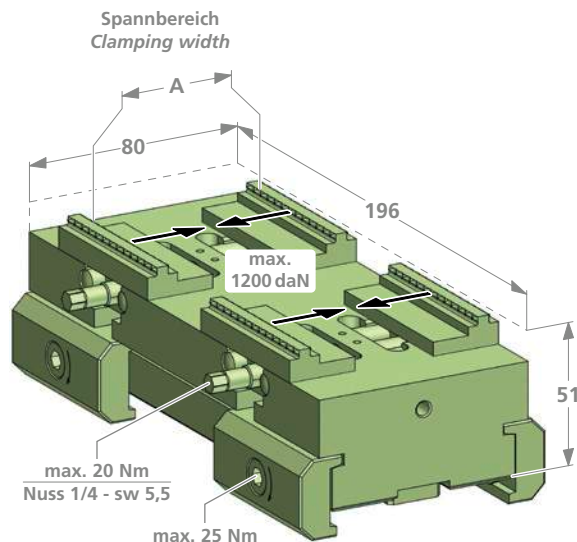

| Drehmoment Torque | | Spannkraft Workholding force | | |
|----------------------|---------|---------------------------------|-------|------|
| Nm | (lb-ft) | ~daN | ~(lb) | ~t |
| 5 | 3,7 | = 410 | 900 | 0,41 |
| 10 | 7,4 | = 830 | 1'830 | 0,83 |
| 15 | 11,0 | = 1'250 | 2'760 | 1,25 |
| 20 | 14,8 | = 1'650 | 2'640 | 1,65 |



Linear- Spannbacke / Linear clamping jaw →

| Art. Nr. | B210-62 | B212W11-60 | B212W20-60 |
|-----------|----------------|---|---|
| i | 57HRC | Vergütungsstahl Tempering steel (1.7225) | Vergütungsstahl Tempering steel (1.7225) |
| kg | ~0,31 | ~0,31 | ~0,52 |
| | | | |

Weich, zur Herstellung individueller Formbacke. / Soft, for the production of individual moulding jaw.

NUSS 1/4" 5.5MM

WICHTIG!
Bitte separat bestellen
IMPORTANT!
Please order separately





Zwei Mini - Zentrischspanner mit Direktprägebacken halten verschieden lange Titanbleche. Um die verschiedenen Längen zu adaptieren, können die Spanner in 2 mm schritten seitlich versetzt werden.

Two mini - self centering vises with direct stamping jaws holding titanium sheets in different length. To adapt the different length's the vises can be moved side words in 2 mm steps.

Sondervorrichtung für Velo-Pedale mit dem schnellwechsel Nullpunkt-System OPP
Dedicated fixture for high end bicycle pedals with quick change system OPP

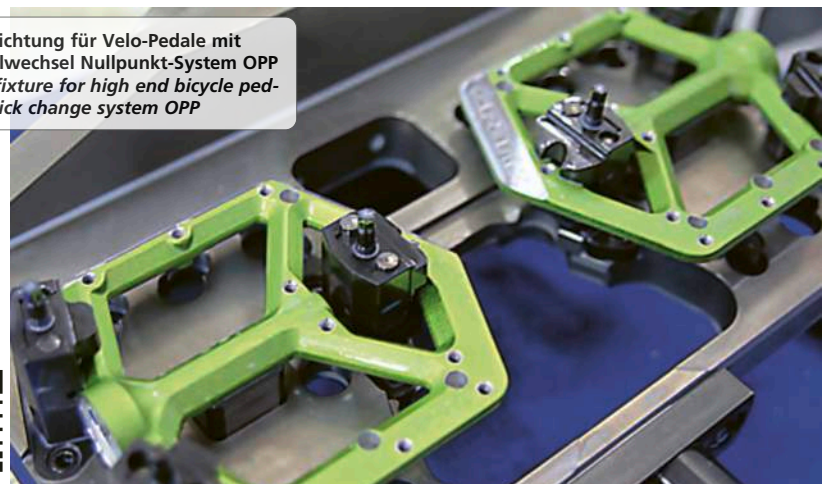

siehe Video
see video



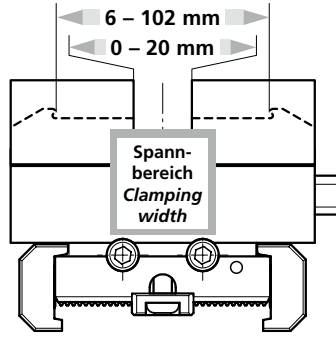
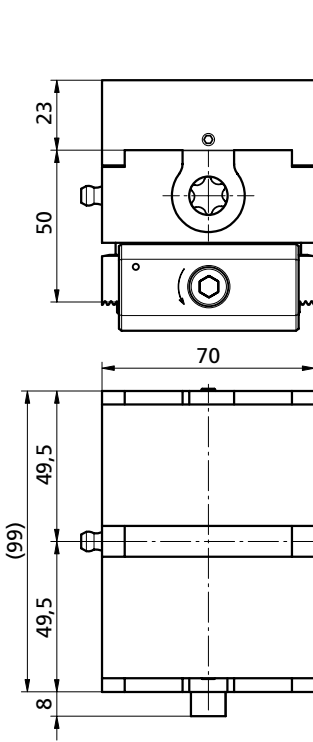

| Drehmoment Torque | | Spannkraft Workholding force | | |
|----------------------|---------|---------------------------------|-------|-----|
| Nm | (lb-ft) | ~daN | ~(lb) | ~t |
| 10 | 7,4 | = 200 | 440 | 0,2 |
| 20 | 14,8 | = 500 | 1'102 | 0,5 |
| 30 | 22,2 | = 1'000 | 2'204 | 1,0 |
| 40 | 29,6 | = 1'300 | 2'866 | 1,3 |
| 50 | 37,0 | = 1'600 | 3'527 | 1,6 |

Innenspannung-Set / Inner clamping set

Mit diesem Set ist es möglich das Werkstück von innen zu spannen. *With this set it is possible to clamp the workpiece from the inside.*

ACHTUNG / CAUTION

Folgende Spannbacken sind dazu nicht geeignet.

The following clamping jaws are not suitable for this purpose.

B175-102, B175-121, B173-102

PCZS2439-ID-SET

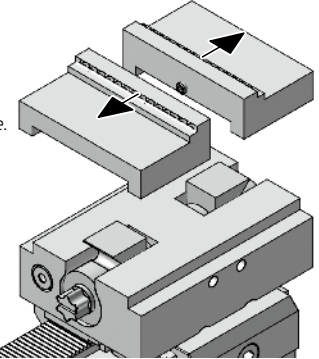

Nullpunkt des Zentrischspanners neu einstellen
How to readjust the zero point adjustment

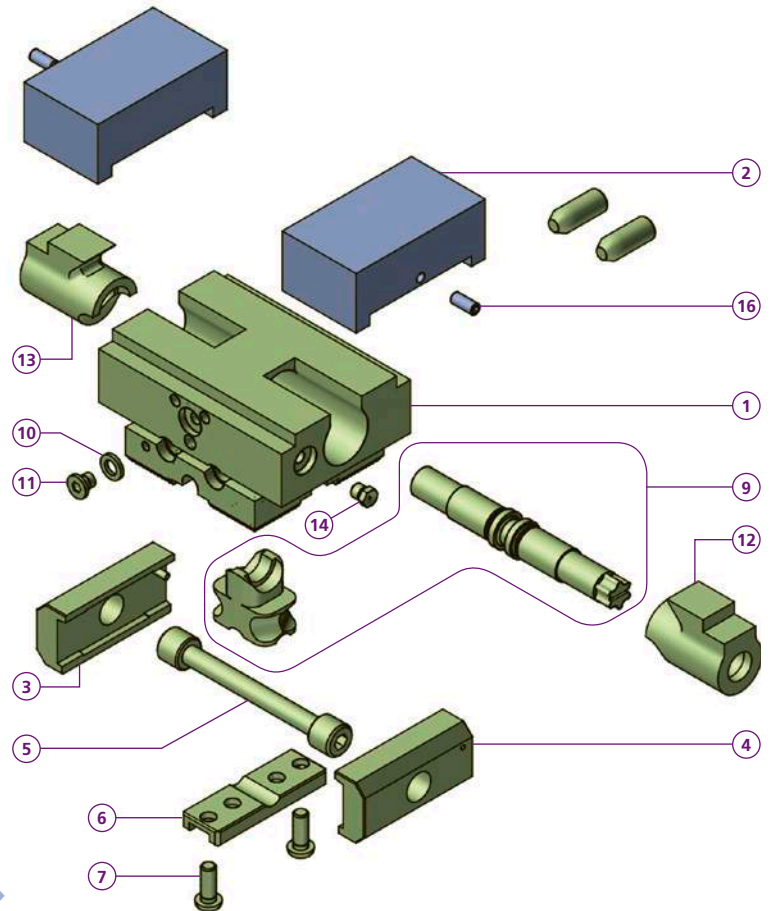
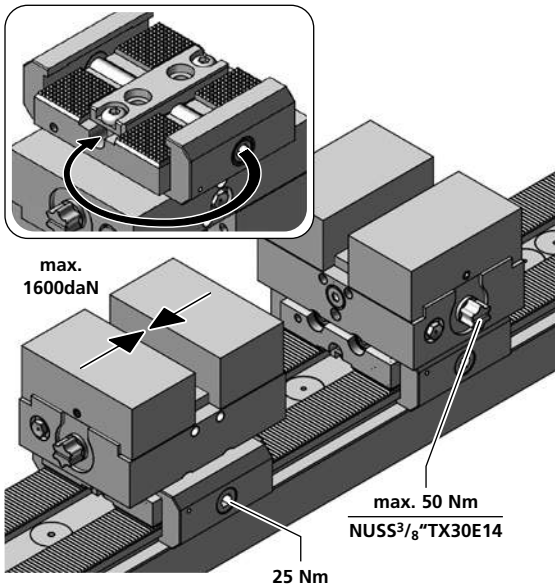

| PCZ100L50 | |
|-----------|----------------------|
| 1 | 1x PCZ100L50M |
| 2 | 2x — |
| 3 | 1x PCSP60L |
| 4 | 1x PCSP60R |
| 5 | 1x PCS14 |
| 6 | 1x PCGUW20 |
| 7 | 2x M6X16ISO7380 |
| 9 | 1x PCS14M107SET |
| 10 | 1x BN726 ISO 7092 M6 |
| 11 | 1x BN1206 M6x6 |
| 12 | 1x PCZS2439L |
| 13 | 1x PCZS2439R |
| 14 | 1x PCZSNP |
| 15 | 4x PCZJ1025 |
| 16 | 2x TN100140 |
| kg | ~2,5 |

p. 128 - 129

NUSS3/8"TX30E14

WICHTIG!
Bitte separat bestellen
IMPORTANT!
Please order separately



Bestellbeispiel / Ordering example:
3 x PCZ100L50 & 6 x B170 & 1 x NUSS3/8"TX30E14

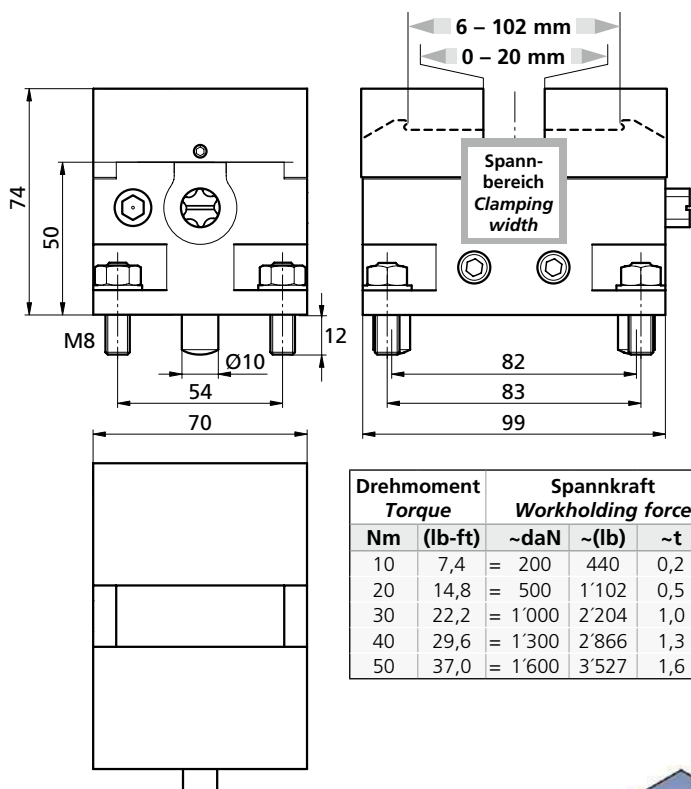

| Drehmoment Torque | | Spannkraft Workholding force | | |
|----------------------|---------|---------------------------------|-------|-----|
| Nm | (lb-ft) | ~daN | ~(lb) | ~t |
| 10 | 7,4 | = 200 | 440 | 0,2 |
| 20 | 14,8 | = 500 | 1'102 | 0,5 |
| 30 | 22,2 | = 1'000 | 2'204 | 1,0 |
| 40 | 29,6 | = 1'300 | 2'866 | 1,3 |
| 50 | 37,0 | = 1'600 | 3'527 | 1,6 |

Innenspannung-Set / Inner clamping set

Mit diesem Set ist es möglich das Werkstück von innen zu spannen. *With this set it is possible to clamp the workpiece from the inside.*

ACHTUNG / CAUTION

Folgende Spannbacken sind dazu nicht geeignet.
The following clamping jaws are not suitable for this purpose.

B175-102, B175-121,
B173-102

PCZS2439-ID-SET

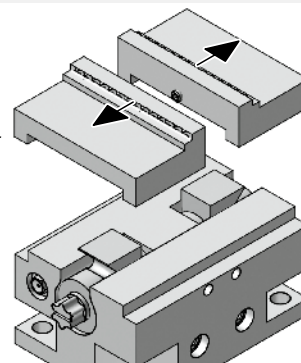

Nullpunkt des Zentrischspanners neu einstellen
How to readjust the zero point adjustment

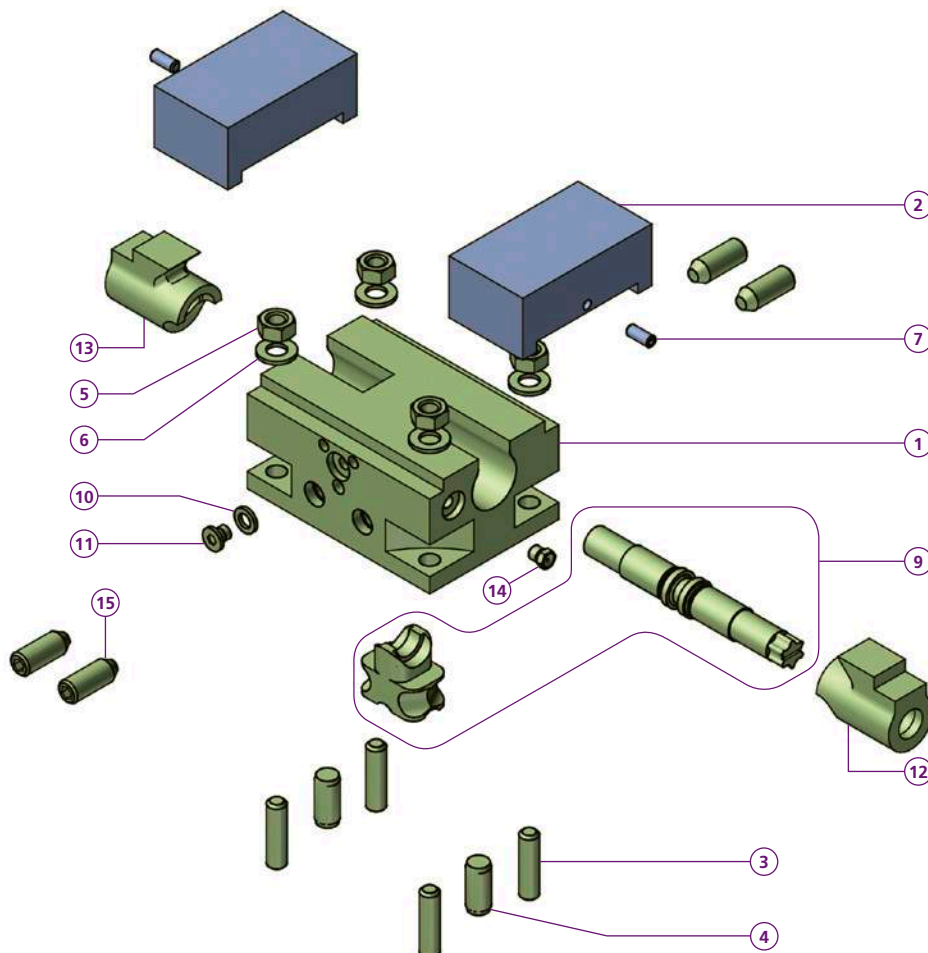
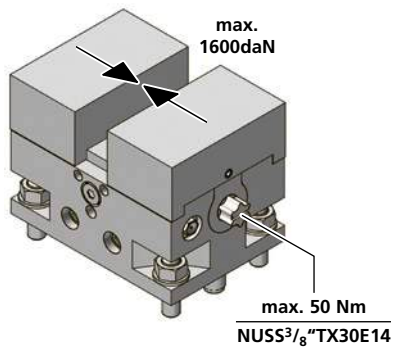

| MCZ100L50 | |
|-----------|----------------------|
| 1 | 1x MCZ100L50M |
| 2 | 2x — |
| 3 | 2x 10m6x22 ISO 8734 |
| 4 | 4x M8X30DIN913 |
| 5 | 4x M8 DIN 934 |
| 6 | 4x 8,4 DIN 125 A |
| 7 | 2x TN100140 |
| 9 | 1x PCS14M107SET |
| 10 | 1x BN726 ISO 7092 M6 |
| 11 | 1x BN1206 M6x6 |
| 12 | 1x PCZS2439L |
| 13 | 1x PCZS2439R |
| 14 | 1x PCZSNP |
| 15 | 4x PCZJ1025 |
| kg | ~2,6 |

p. 128 - 129

NUSS3/8"TX30E14

WICHTIG!
Bitte separat bestellen
IMPORTANT!
Please order separately

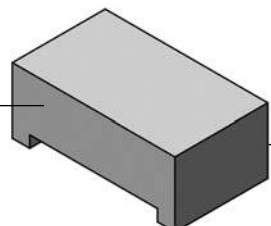
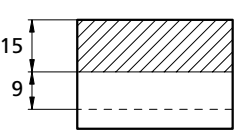
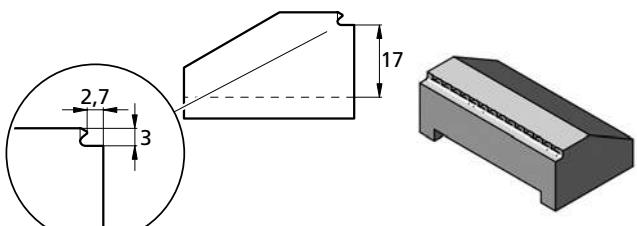
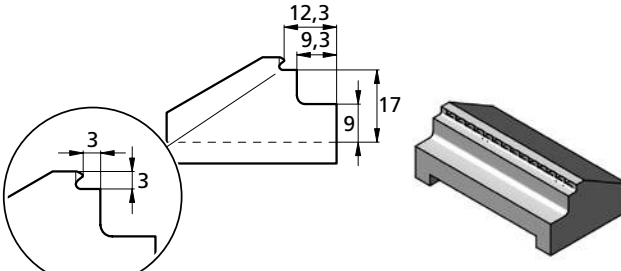
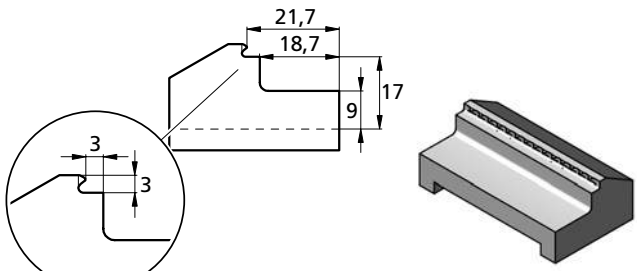
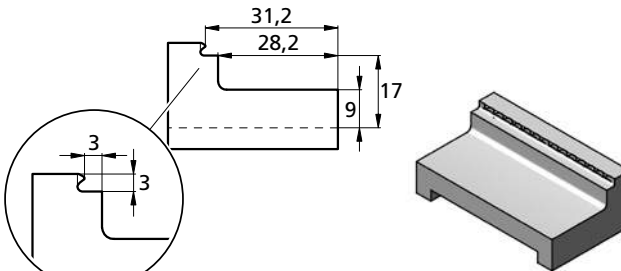
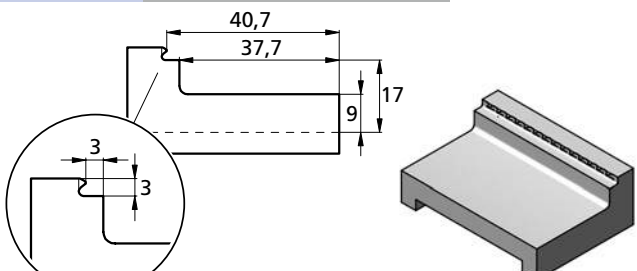
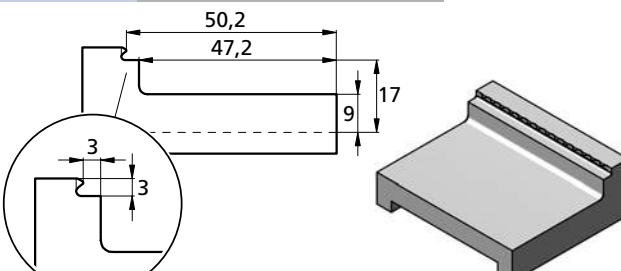

Bestellbeispiel / Ordering example:
3 x MCZ100L50 & 6 x B170 & 1 x NUSS3/8"TX30E14

| | |
|--|--|
| <p>B170, B172 Spannereich / Clamping width ◀ 0 – 20 mm ▶</p>  <p>B170 HV700 x 0,2 mm</p> <p>B172 weich / soft 1.7225</p> | <p>Zum Erstellen Ihrer individuellen Formbacke: Schnittzeichnung zum Ermitteln der maximalen Bearbeitungs- profiltiefe</p> <p><i>If a dedicated jaw is being machined:</i> Sectional drawing to determine the maximum machining depth</p>  <p>für / for B170, B172</p> |
| <p>B175-26 Spannereich / Clamping width ◀ 6 – 26 mm ▶</p>  | <p>B175-45 Spannereich / Clamping width ◀ 25 – 45 mm ▶</p>  |
| <p>B175-64 Spannereich / Clamping width ◀ 44 – 64 mm ▶</p>  | <p>B175-83 Spannereich / Clamping width ◀ 63 – 83 mm ▶</p>  |
| <p>B175-102 Spannereich / Clamping width ◀ 82 – 102 mm ▶</p>  | <p>B175-121 Spannereich / Clamping width ◀ 101 – 121 mm ▶</p>  |

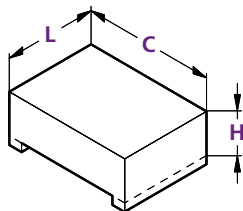

Bestellbeispiel / Ordering example: 2 x B170

| | B170 | B172 | B175-26 | B175-45 | B175-64 | B175-83 | B175-102 | B175-121 | B175SET |
|-----------|-----------------|------|---------|---------|---------|---------|----------|----------|-------------|
| C | 70 | 70 | 70 | 70 | 70 | 70 | 70 | 70 | 2x B175-26 |
| H | 24 | 24 | 20 | 20 | 20 | 20 | 20 | 20 | 2x B175-45 |
| L | 40 | 40 | 40 | 40 | 40 | 40 | 50 | 60 | 2x B175-64 |
| i | HV700 x0,2mm | * | 57HRC | 57HRC | 57HRC | 57HRC | 57HRC | 57HRC | 2x B175-83 |
| kg | ~0,5 | ~0,5 | ~0,34 | ~0,29 | ~0,28 | ~0,25 | ~0,31 | ~0,37 | 2x B175-102 |



* = weich / soft (1.7225 Vergütungsstahl / Tempering steel)

| | |
|---|--|
| <p>B173-26 Spannereich / Clamping width ◀ 6 – 26 mm ▶</p> | <p>B173-45 Spannereich / Clamping width ◀ 25 – 45 mm ▶</p> |
| <p>B173-64 Spannereich / Clamping width ◀ 44 – 64 mm ▶</p> | <p>B173-83 Spannereich / Clamping width ◀ 63 – 83 mm ▶</p> |
| <p>B173-102 Spannereich / Clamping width ◀ 82 – 102 mm ▶</p> | <p>B176-80 Spannereich / Clamping width ◀ 8 – 80 mm ▶</p> <p>2x Inklusive /Included PRG1003M8</p> |
| <p>ZK160798M5</p> <p>Extra Zubehör: Schraube zum schnellen Wechseln der Backen</p> <p>Additional accessories: Screw for quick change of jaws</p> | <p>PRG1003M8</p> <p>Bohrbild Hole pattern</p> |

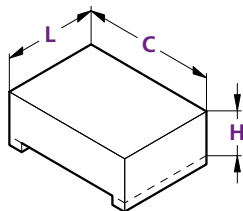

Bestellbeispiel / Ordering example: 2 x B173-26

| B | B173-26 | B173-45 | B173-64 | B173-83 | B173-102 | B176-80 | B173SET |
|-----------|---------|---------|---------|---------|----------|---------|-------------|
| C | 70 | 70 | 70 | 70 | 70 | 70 | 2x B173-26 |
| H | 24 | 24 | 24 | 24 | 24 | 20 | 2x B173-45 |
| L | 40 | 40 | 40 | 40 | 50 | 40 | 2x B173-64 |
| i | HV700 | HV700 | HV700 | HV700 | HV700 | HV700 | 2x B173-83 |
| | x0,2mm | x0,2mm | x0,2mm | x0,2mm | x0,2mm | x0,2mm | 2x B173-102 |
| kg | ~0,31 | ~0,32 | ~0,32 | ~0,28 | ~0,34 | ~0,4 | |

Separat bestellen / Order separately

Doppelte Spannung – doppelt effizient
Twice the clamping – twice the efficiency

| Art. Nr. | kg | Backen Jaws | A = 2 x |
|----------------|------|----------------|----------|
| B172-MB | ~0,3 | B172 | variabel |

weicher Stahl
soft steel (1.7225)

| | | | |
|----------------|------------------|---------|------------|
| B173-MB | ~0,3 | B173-45 | 10 – 17 mm |
| | HV700 x 0,2mm | B173-64 | 17 – 27 mm |

B173-83 27 – 37 mm

B173-102 36 – 46 mm

B175-121 46 – 55 mm

| | | | |
|----------------|-------|---------|------------|
| B175-MB | ~0,3 | B175-45 | 8 – 16 mm |
| | 57HRC | B175-64 | 16 – 26 mm |

B175-83 25 – 35 mm

B175-102 35 – 45 mm

B175-121 45 – 54 mm

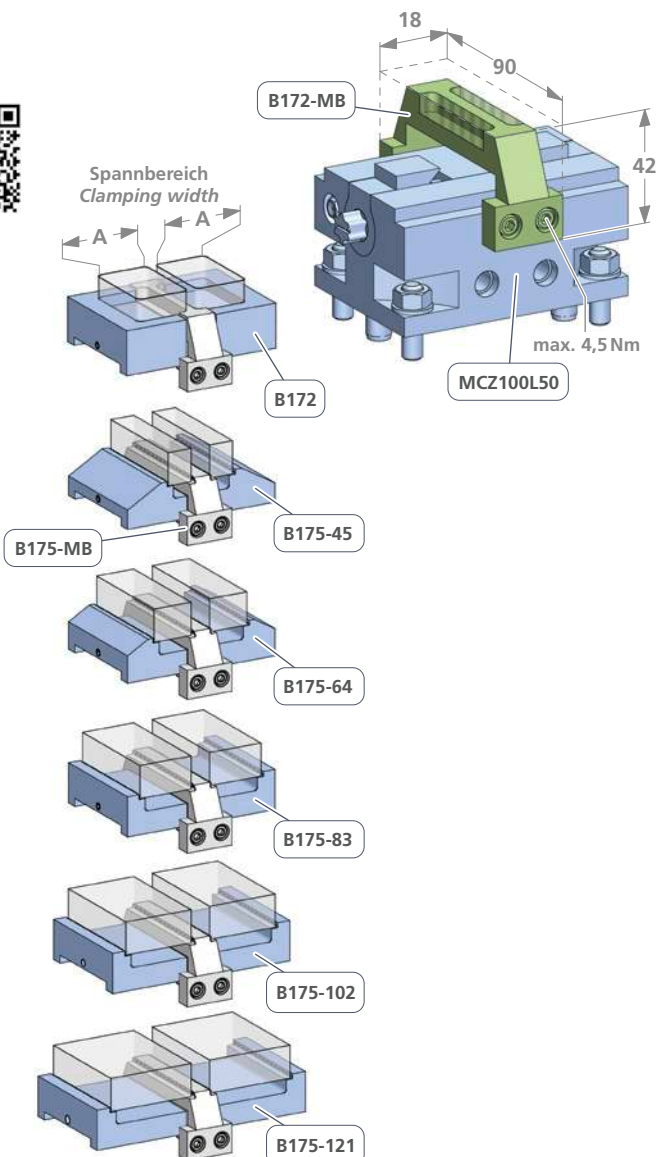

Die Anschlagbrücken **B172-MB**, **B173-MB** und **B175-MB** können in Kombination mit den Zentrischspannern PCZ100L50 / MCZ100L50 als Doppelspanner eingesetzt werden.

The **B172-MB**, **B173-MB**, and **B175-MB** stop bridges can be used as double clamps in combination with the PCZ100L50 / MCZ100L50 self centering vise.

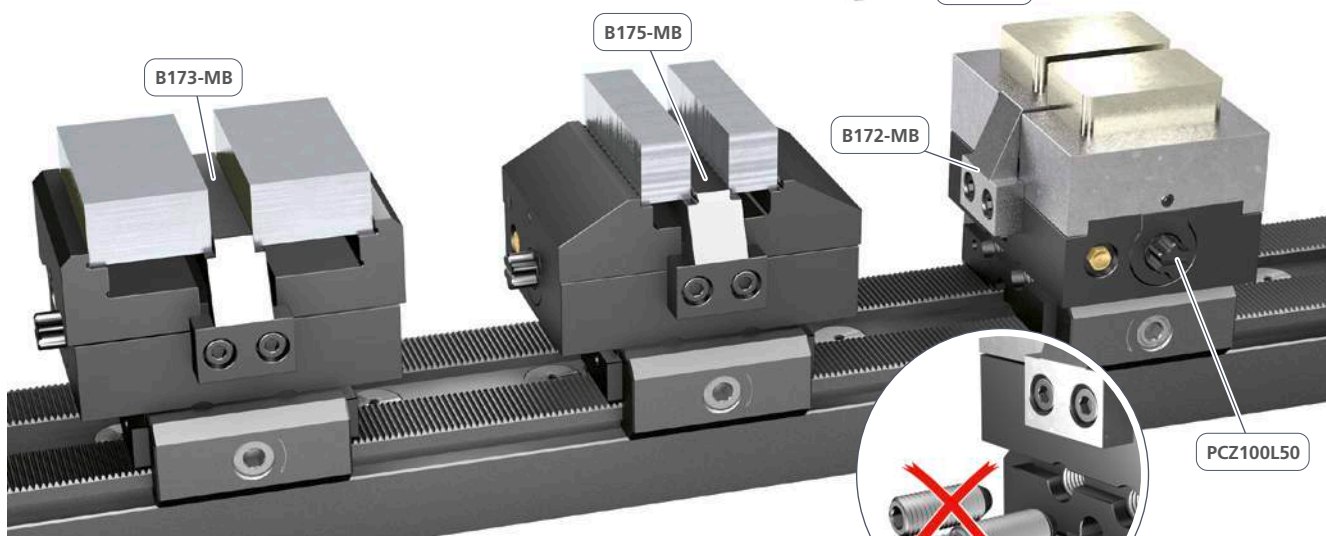

Folgende Spannbacken sind dazu nicht geeignet.

The following clamping jaws are not suitable for this purpose.

B170, **B173-26**, **B175-26**, **B176-80**

ACHTUNG / CAUTION

Beim Einsatz der Anschlagbrücke muss der Spanner schwimmend eingestellt werden, dabei werden die vier Zentrierschrauben entfernt.

When using the stop bridge, the tensioner must be adjusted to float, removing the four centring screws in the process.

Montageanleitung der Anschlagbrücke auf dem Mini-Zentrischspanner
Operating instructions for this pneumatic self centering vise



MINI

Zentrischspanner mit Anschlagbrücke
Self centering vise with center stop

triCENTRO

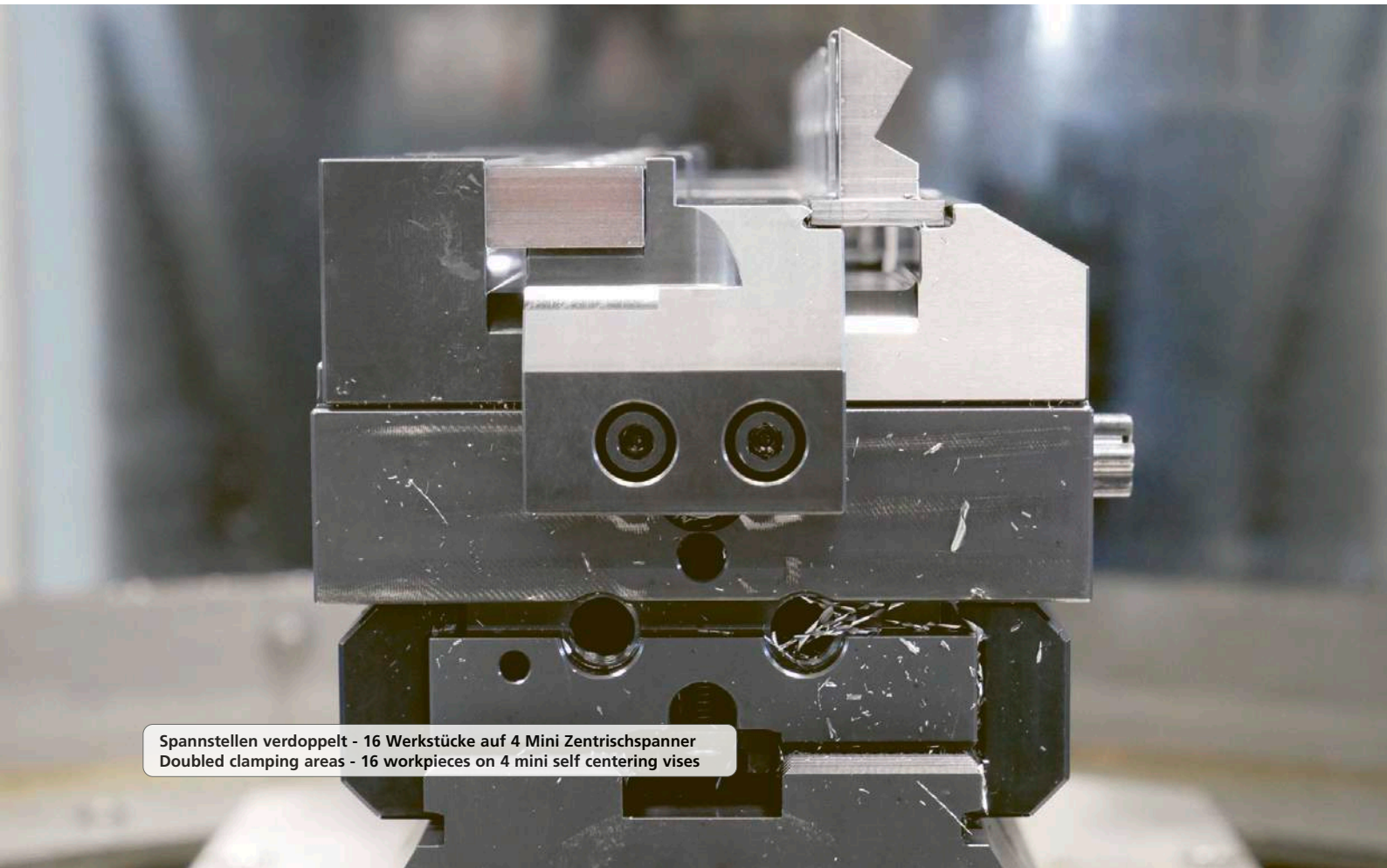
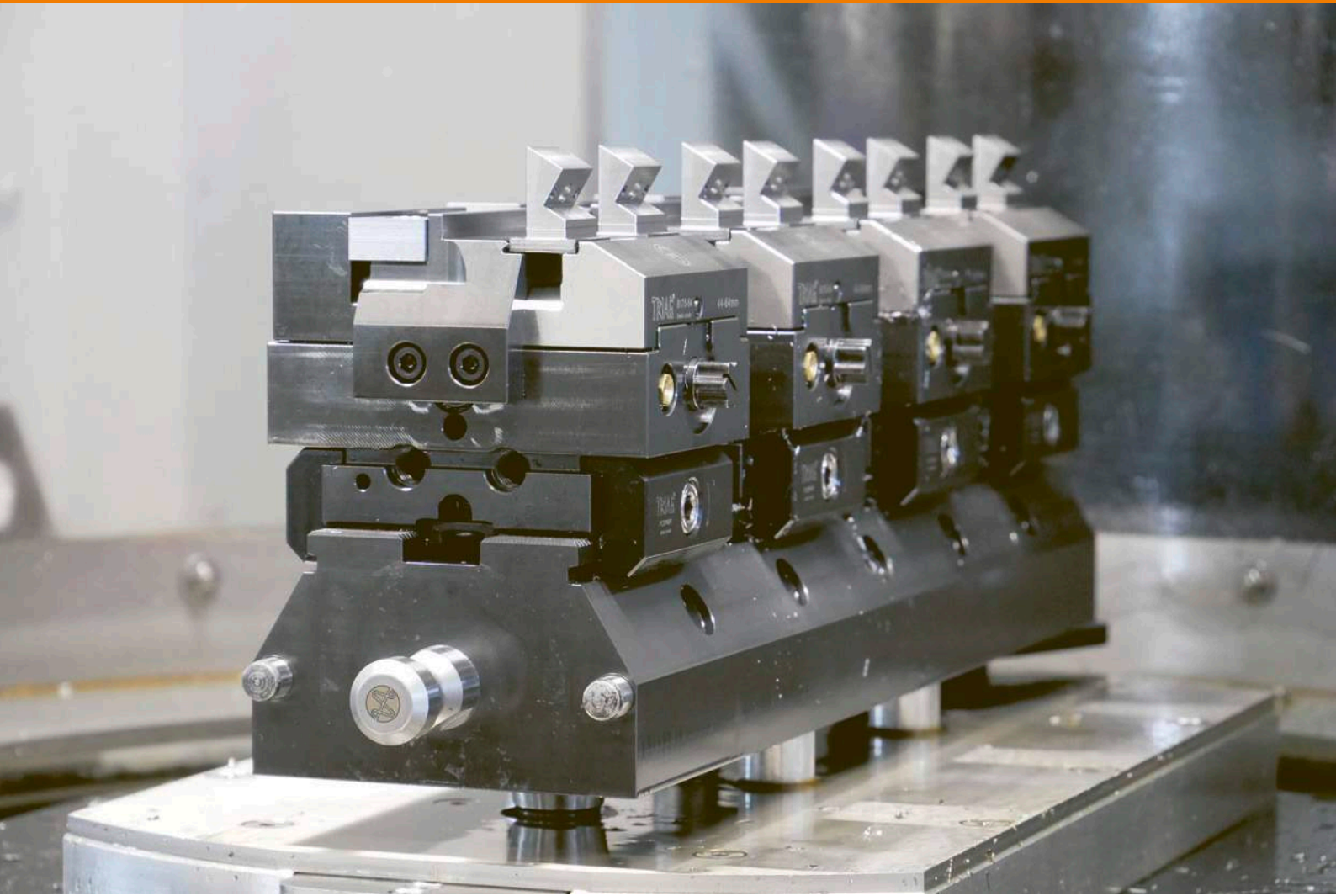

Spannstellen verdoppelt - 16 Werkstücke auf 4 Mini Zentrischspanner
Doubled clamping areas - 16 workpieces on 4 mini self centering vises

Diese Spannbacken sind für die Innenspannung geeignet.
These clamping jaws are suitable for internal clamping.

Diese Spannbacken sind für die Spannung mit der Anschlagbrücke geeignet.
These clamping jaws are suitable for clamping with the stop bridge.

PCZ100L50 MCZ100L50 p. 130 B172-MB PCZS2439-ID-SET p. 126

14 verschiedene Backenvarianten passend zu dieser Schnellwechselschnittstelle.
More than 14 different jaw modules to match this rapidly changing interface.

SPACEGRIP II

spaceGRIP II

Ein einzigartig auf Modulbauweise ausgelegtes Spannkonzzept für den Einsatz der Zentrischspanner **MCZ100L50**.

Es können 4, 8 oder gar 12 Spanner, je nach Wunsch, eingesetzt werden. Das Ganze ist so modular wie ein «Lego»-Baukasten-System. Wieder stehen Prägebacken, weiche Backen und zusätzlich Stufen- und Universalbacken zur Verfügung. Sogar das Zentrum der einzelnen Spannstöcke kann eingestellt werden.

spaceGRIP II

A unique clamping concept with modular construction design for using the self-centering vice **MCZ100L50**.

Four, eight or even twelve clamping vices can be used as needed. The whole system is modular like a «Lego» building kit. Again, stamping jaws, soft jaws and universal as well as stepped jaws are available. Even the centre of the individual vices can be adjusted.

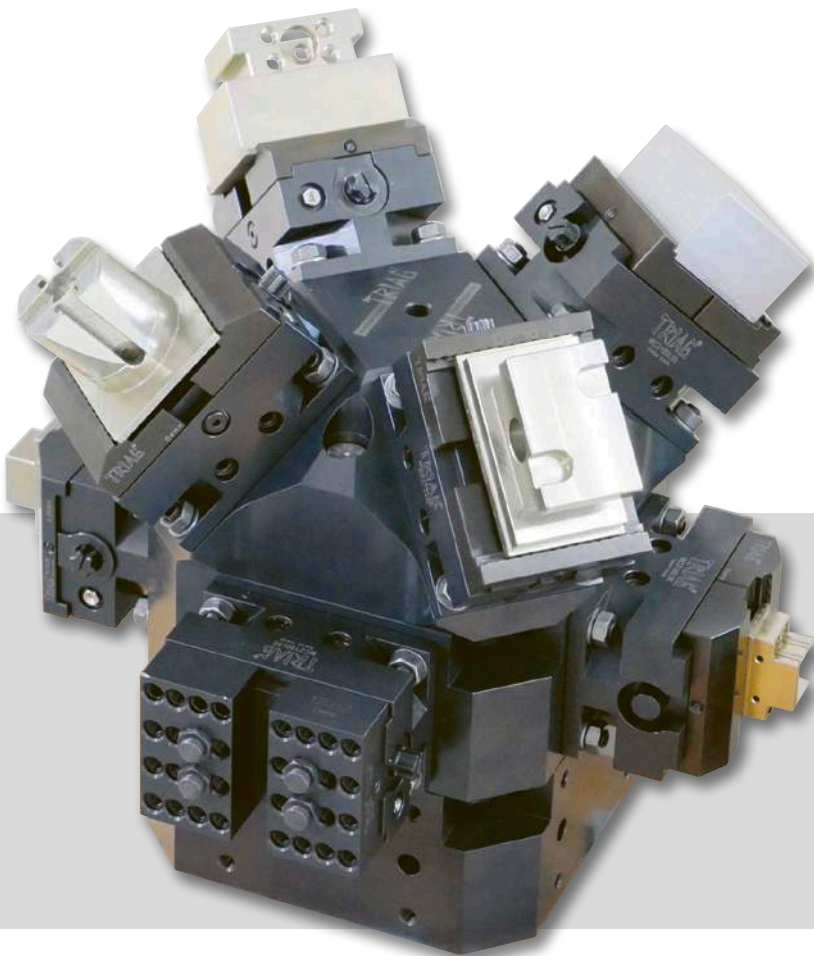

SPACEGRIP II

SPACEGRIP II

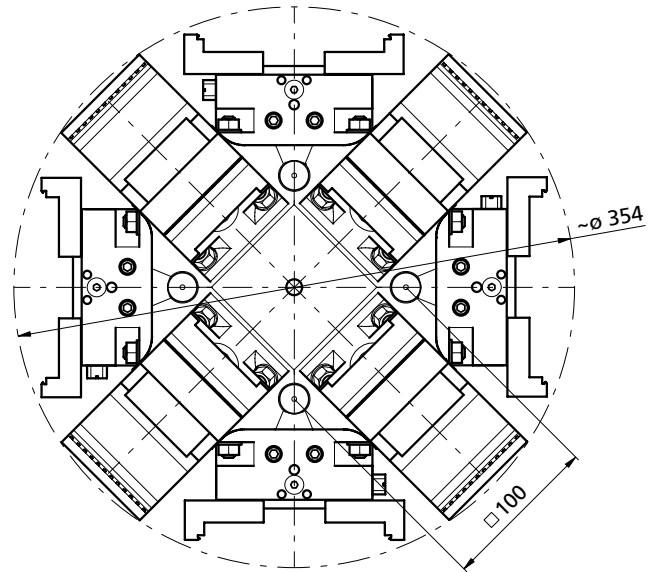
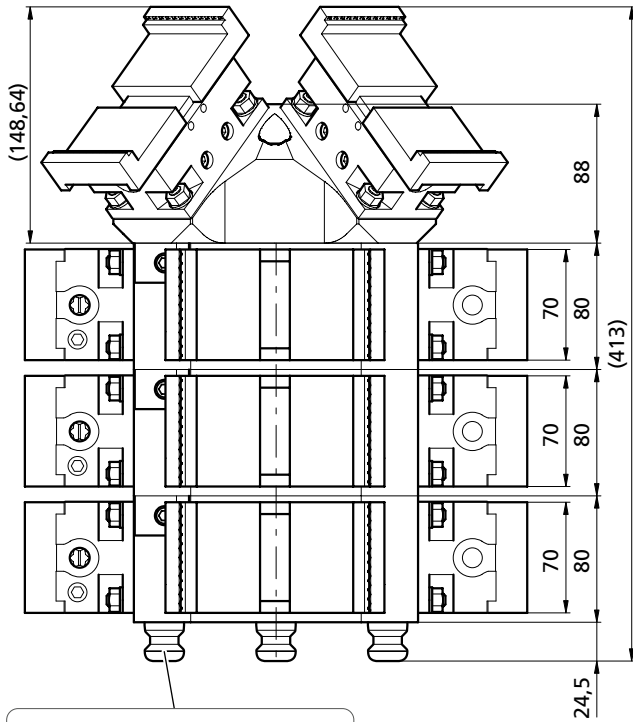

OPP-Schnittstelle Nullpunkt-System
OPP interface Zero-point system

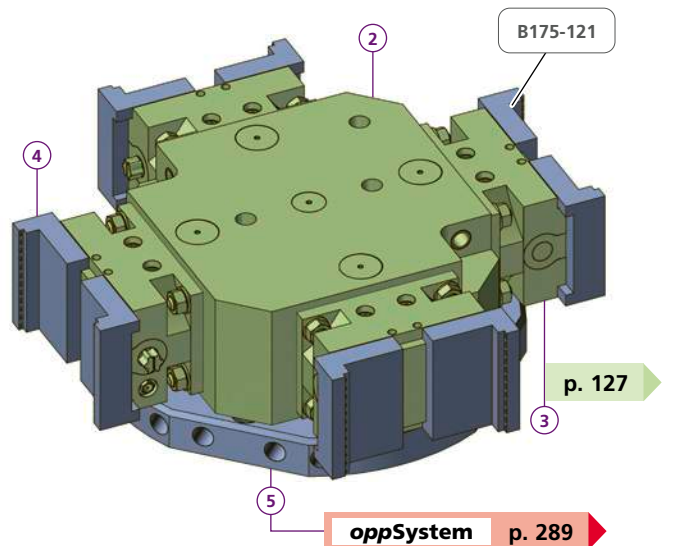
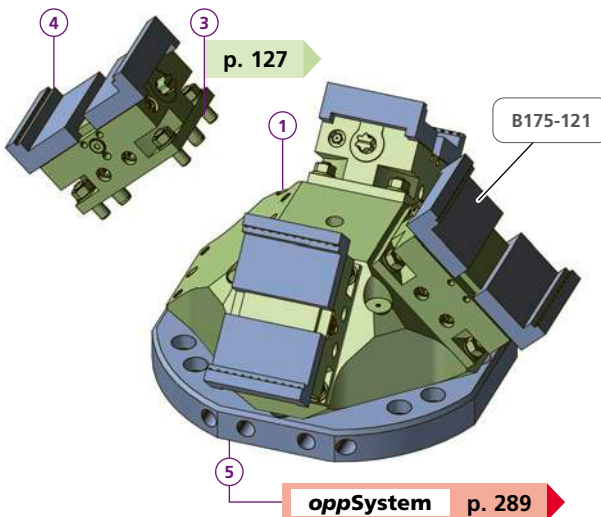

| | |
|-----------------------|---------------------------------|
| 5AXMCZ100-45-4 | |
| 1 | 1x TS160110 |
| 3 | 4x MCZ100L50 |
| 4 | 8x p. 128 - 129 |
| 5 | 1x TB160379 |
| kg | ~26 |



Detailzeichnung
zu dieser
Schnittstelle
Detail drawing
to interface

| | |
|-----------------------|---------------------------------|
| 5AXMCZ100-90-4 | |
| 2 | 1x TS160111 |
| 3 | 4x MCZ100L50 |
| 4 | 8x p. 128 - 129 |
| 5 | 1x TB160379 |
| kg | ~28,7 |



Detailzeichnung
zu dieser
Schnittstelle
Detail drawing
to interface

Separat bestellen / Order separately

Bestellbeispiel / Ordering example : 1 x 5AXMCZ100-90-4 & 8 x B175-121

SPACEGRIP II

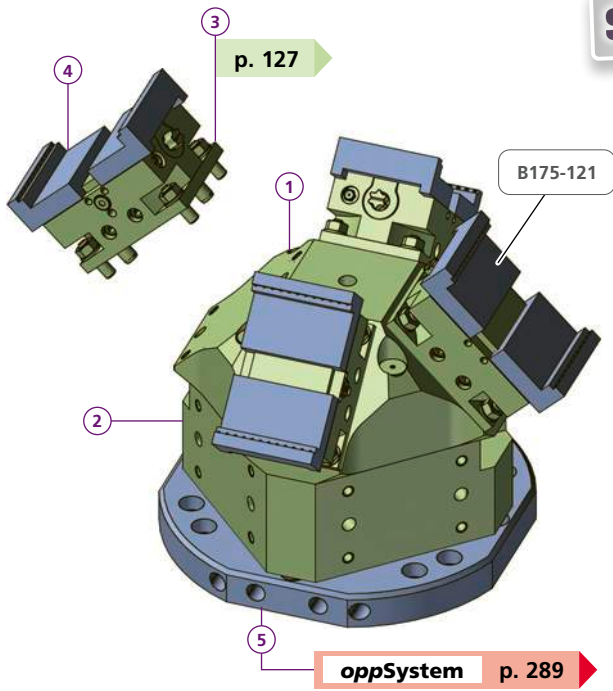

| | |
|------------------------|-----------------------|
| 5AXMCZ100-45-4H | |
| 1 | 1x TS160110 |
| 2 | 1x TS160111 |
| 3 | 4x MCZ100L50 |
| 4 | 8x ————— p. 128 - 129 |
| 5 | 1x TB160379 |
| kg | ~41,2 |



Detailzeichnung zu dieser Schnittstelle
Detail drawing to interface

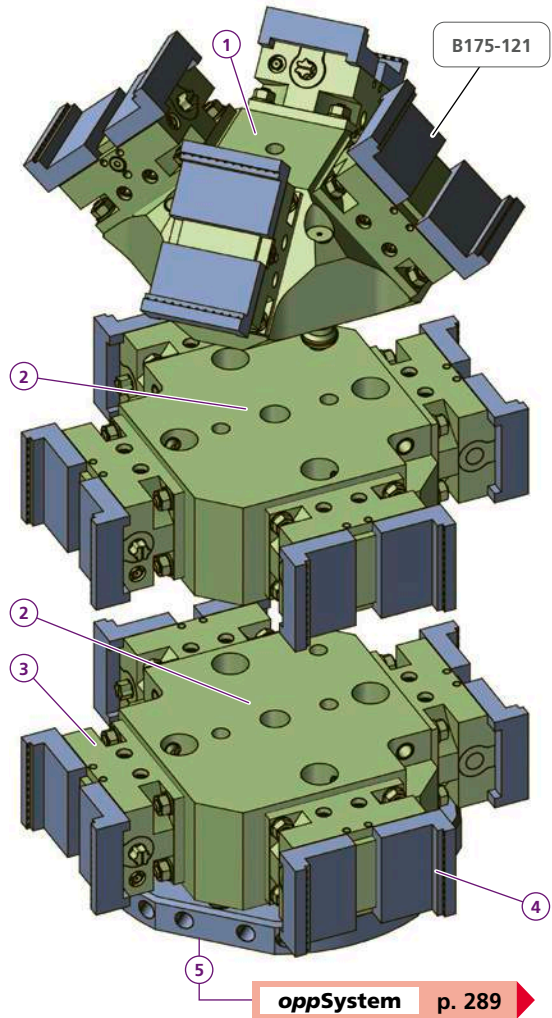

| | |
|------------------------|------------------------|
| 5AXMCZ100-45-12 | |
| 1 | 2x TS160110 |
| 2 | 1x TS160111 |
| 3 | 12x MCZ100L50 |
| 4 | 24x ————— p. 128 - 129 |
| 5 | 1x TB160379 |
| kg | ~83,3 |



Detailzeichnung zu dieser Schnittstelle
Detail drawing to interface

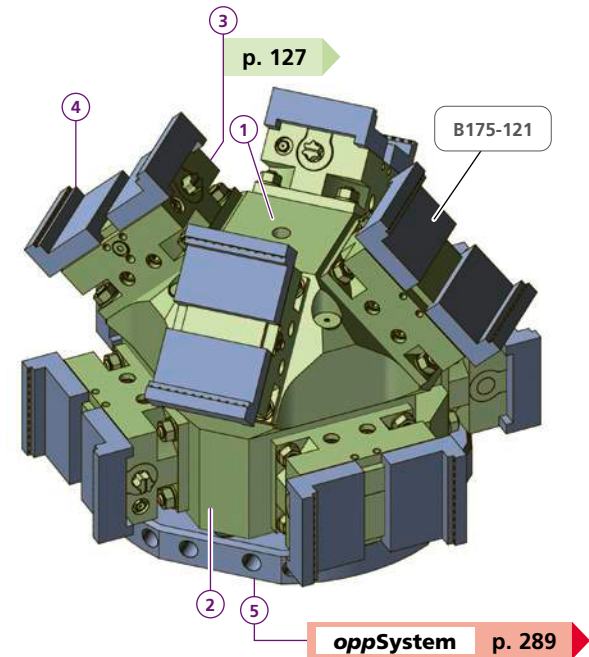

| | |
|-----------------------|------------------------|
| 5AXMCZ100-45-8 | |
| 1 | 1x TS160110 |
| 2 | 1x TS160111 |
| 3 | 8x MCZ100L50 |
| 4 | 16x ————— p. 128 - 129 |
| 5 | 1x TB160379 |
| kg | ~54,6 |



Detailzeichnung zu dieser Schnittstelle
Detail drawing to interface

Bestellbeispiel / Ordering example: 1 x 5AXMCZ100-45-8 & 16 x B175-121

SPACEGRIP II-3 

| Art. Nr. | kg |
|-----------------|-----|
| 5AXMCZ100-45-3 | ~19 |
| 5AXMCZ100-45-3H | ~35 |
| 5AXMCZ100-45-6 | ~43 |



Bei dieser Pyramidenlösung ist die Zugänglichkeit der Spindel beim Bearbeiten von Werkstücken sehr gut.

With this pyramid solution, the accessibility of the spindle is very good when machining workpieces.

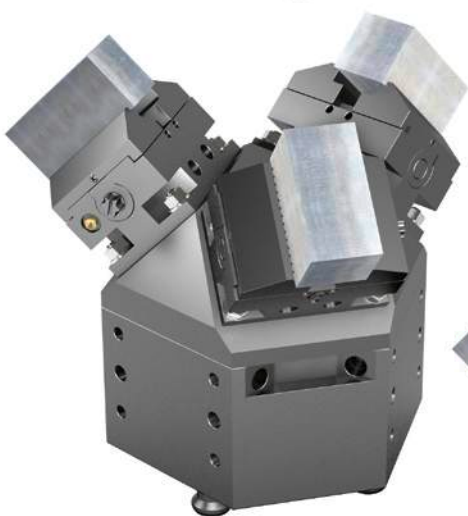
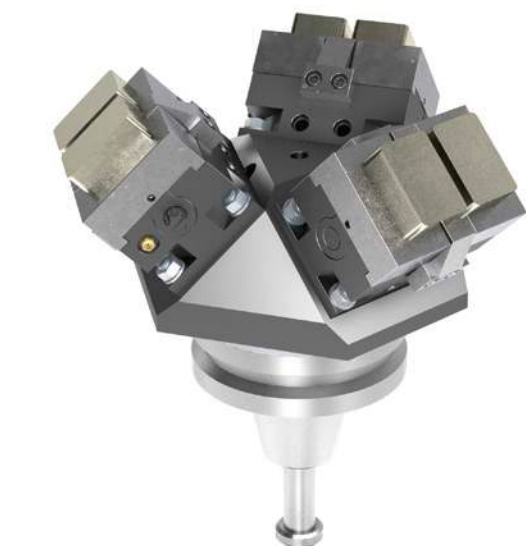
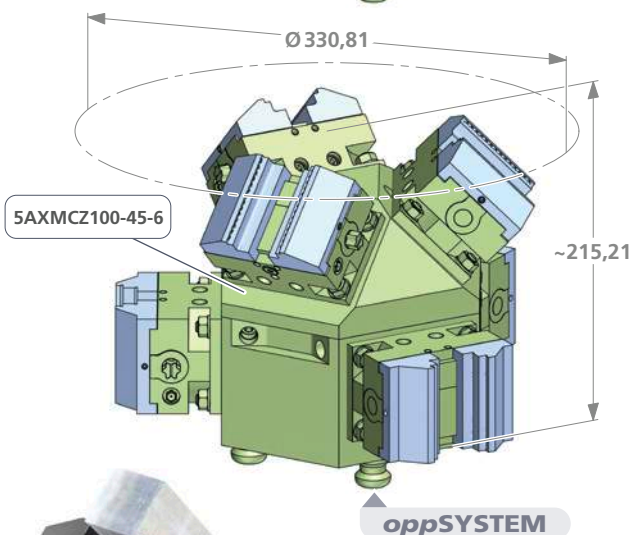
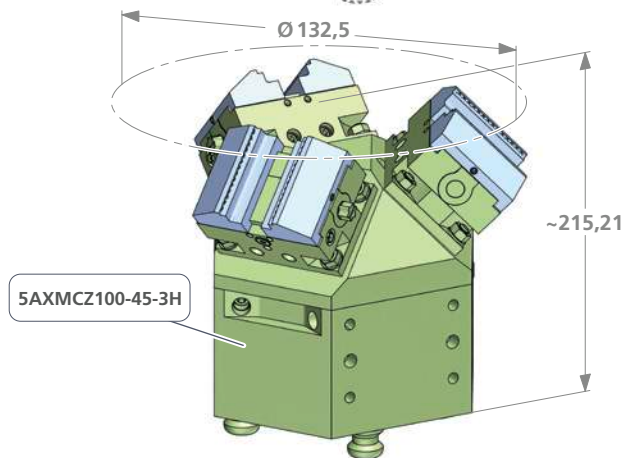
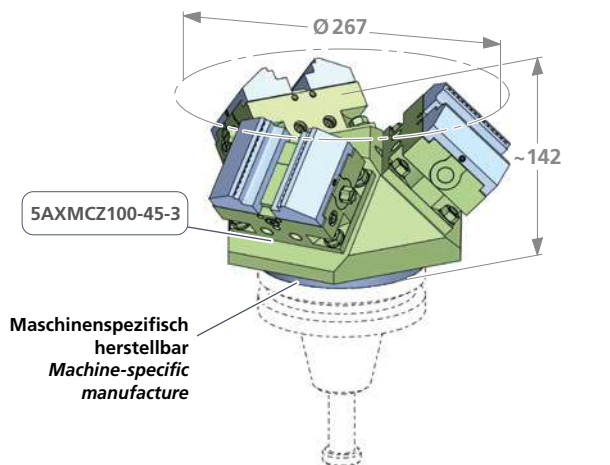

Durchgehend modular!

Clevere Zentrischspanner passen sich der Maschine, den Werkstücken und den Anforderungen an.

Throughout modular!

Clever self centering vises which adapts to the machine, the workpiece and the requirements.



**Spannkrafterhaltung
und Nachfederung**

*Spring loaded
mechanism to maintain
clamping force*



Mehr als **64** verschiedene
Backenvarianten passend
zu dieser Schnellwechsel-
schnittstelle.

*More than 64 different
jaw modules to match this
rapidly changing interface.*



**Schnellwechselbacken
Spannkrafterhaltung
und Nachfederung**

*Quick-change jaws
Spring loaded
mechanism to maintain
clamping force*

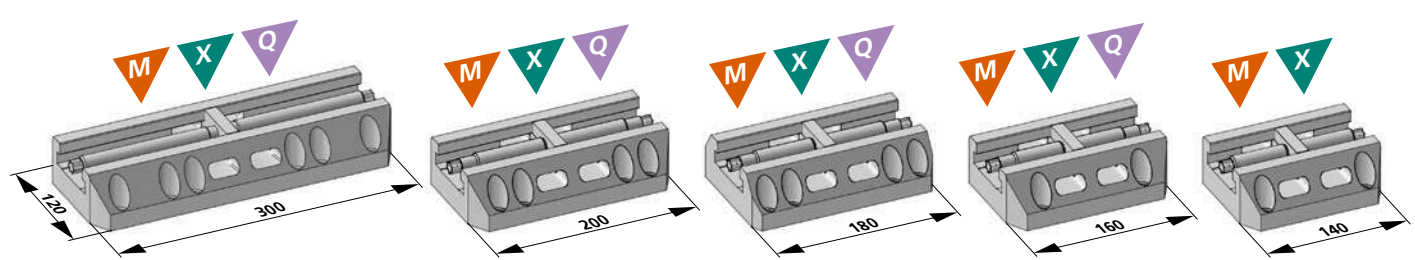
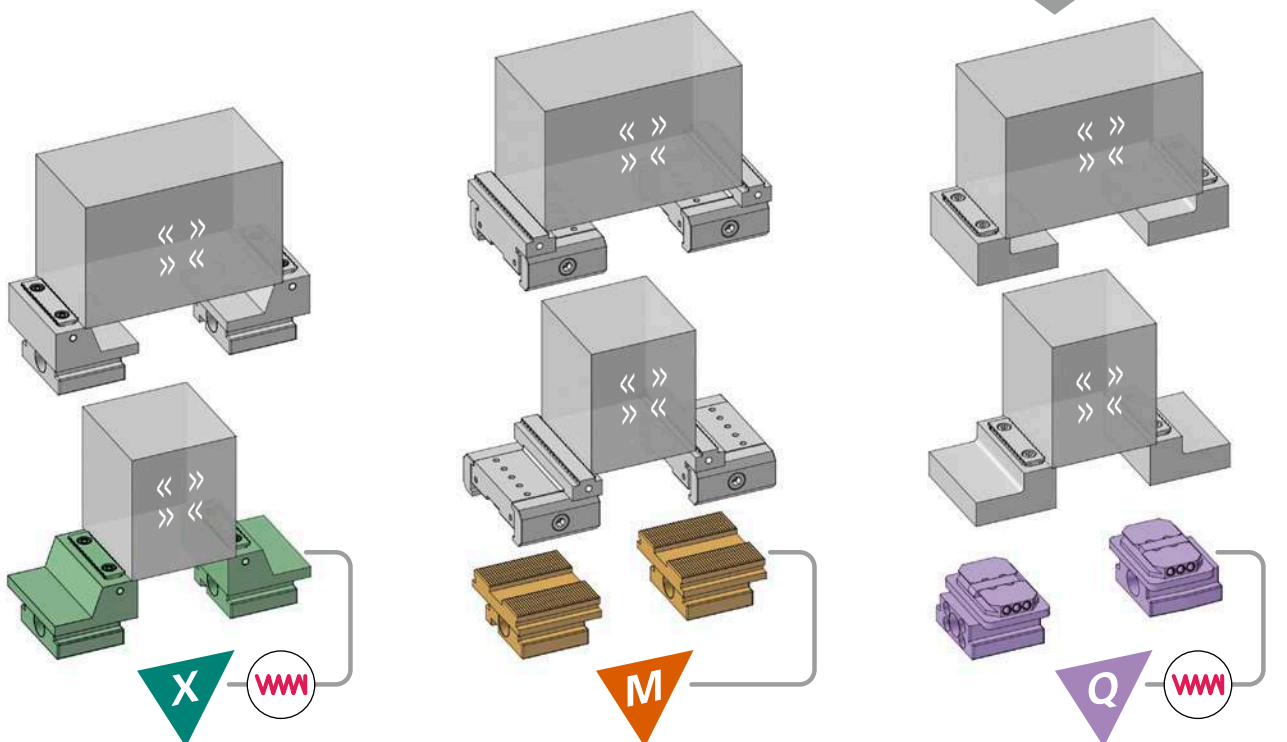

| Art. Nr. | kg |
|------------------------|--------|
| ZS X 300L50UPRG | ~10,65 |
| ZS X 200L50UPRG | ~8,8 |
| ZS X 180L50UPRG | ~8,1 |
| ZS X 160L50UPRG | ~7,7 |
| ZS X 140L50UPRG | ~7,1 |

| Art. Nr. | kg |
|------------------------|-------|
| ZS M 300L50UPRG | ~10,5 |
| ZS M 200L50UPRG | ~7,4 |
| ZS M 180L50UPRG | ~6,9 |
| ZS M 160L50UPRG | ~6,4 |
| ZS M 140L50UPRG | ~5,7 |

| Art. Nr. | kg |
|------------------------|-------|
| ZS Q 300L50UPRG | ~11,1 |
| ZS Q 200L50UPRG | ~8,1 |
| ZS Q 200L50UPRG | ~8,1 |
| ZS Q 180L50UPRG | ~7,5 |
| ZS Q 160L50UPRG | ~7,0 |

Zentrischspanner mit Spannkrafterhaltung und Direkt-Prägebacken

- ✓ für die erste Aufspannung mittels Direkt-Prägebacken ab 3 mm
- ✓ Einzigartiges integriertes Federpaket
- ✓ Beste Zugangs-Möglichkeit
- ✓ für OP10 und OP20 ausgelegt
- ✓ Bestens geeignet für 5-Achsen Maschinen mit kleinerem Tisch
- ✓ Bestens geeignet für den Einsatz auf Rundtischen

Self-centering vise with spring loaded mechanism and direct stamping jaws

- ✓ for the first clamping using direct stamping jaws from 3 mm
- ✓ Unique integrated spring package
- ✓ Best access option
- ✓ Designed for OP10 and OP20
- ✓ Ideally suited for 5-axis machines with smaller tables
- ✓ Ideally suited for use on rotary tables

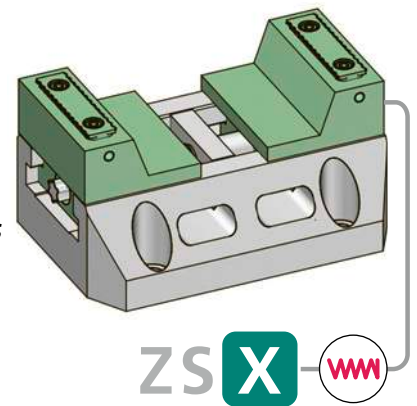

ZSX

Zentrischspanner für den Einsatz mit Power Clamp Modulen

- ✓ Höchste Modularität, alle Power Clamp Module können eingesetzt werden
- ✓ Schneller Backenwechsel (eine Schraube lösen und Modul nach oben abheben)
- ✓ Backen von 19 bis 150 mm
- ✓ weiche Backen
- ✓ Direktprägebacken und Bearbeitung ab 3 mm

Self-centering vice for use with Power Clamp modules

- ✓ Highest modularity, all Power Clamp modules can be used
- ✓ Quick jaw change (loosen one screw and lift the module up)
- ✓ Jaws from 19 to 150 mm
- ✓ soft jaws
- ✓ Direct stamping jaws, machining from 3 mm

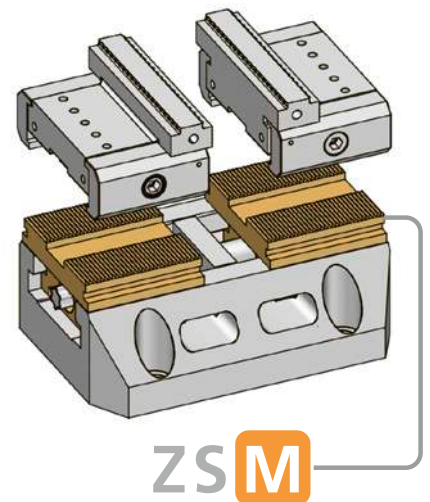

ZSM

Zentrischspanner für den Einsatz von Schnellwechselbacken

- ✓ Schnellwechselbacken (werden per Hand auf dem Spanner eingeklinkt)
- ✓ Weiche Backen zum selbst bearbeiten
- ✓ Direktprägebacken für OP10
- ✓ Einzigartiges integriertes Federpaket
- ✓ Für Rohteile können pendelnde Schlitten (P) eingesetzt werden

Self-centering vice for the use of quick-change jaws

- ✓ Quick-change jaws (clicked on the vise by hand)
- ✓ Soft jaws for individual machining
- ✓ Direct stamping jaws for OP10
- ✓ Unique integrated spring package
- ✓ Pendulum slides (P) can be used for unmachined parts

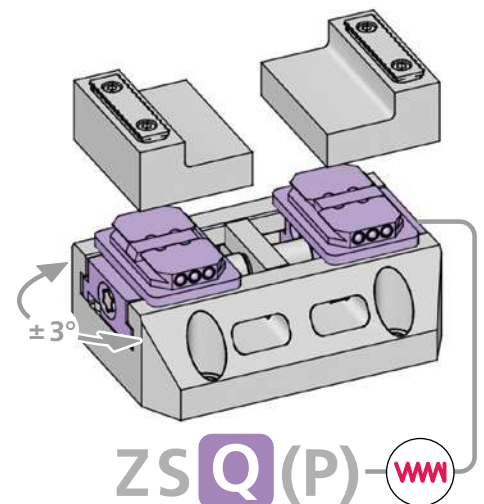

ZSQ(P)

| Drehmoment Torque | | Spannkraft Workholding force | | | Gut zu Wissen Good to know |
|----------------------|---------|---------------------------------|-------|-----|--|
| Nm | (lb-ft) | ~daN | ~(lb) | ~t | |
| 10 | 7,4 | = 200 | 440 | 0,2 | Diese Spannkraften werden für den Dauerbetrieb empfohlen! These clamping forces are recommended for continuous operation! |
| 20 | 14,8 | = 500 | 1'102 | 0,5 | |
| 30 | 22,2 | = 1'000 | 2'204 | 1,0 | |
| 40 | 29,6 | = 1'300 | 2'866 | 1,3 | |
| 50 | 37,0 | = 1'600 | 3'527 | 1,6 | |
| 60 | 44,4 | = 1'800 | 3'968 | 1,8 | Für kurzfristige Anwendung For short-term application |
| 70 | 51,8 | = 2'100 | 4'629 | 2,1 | |

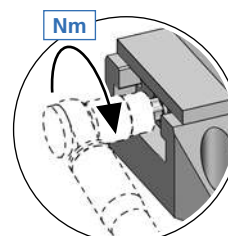

ZSM200L50 & PAND94-49PRG-A1

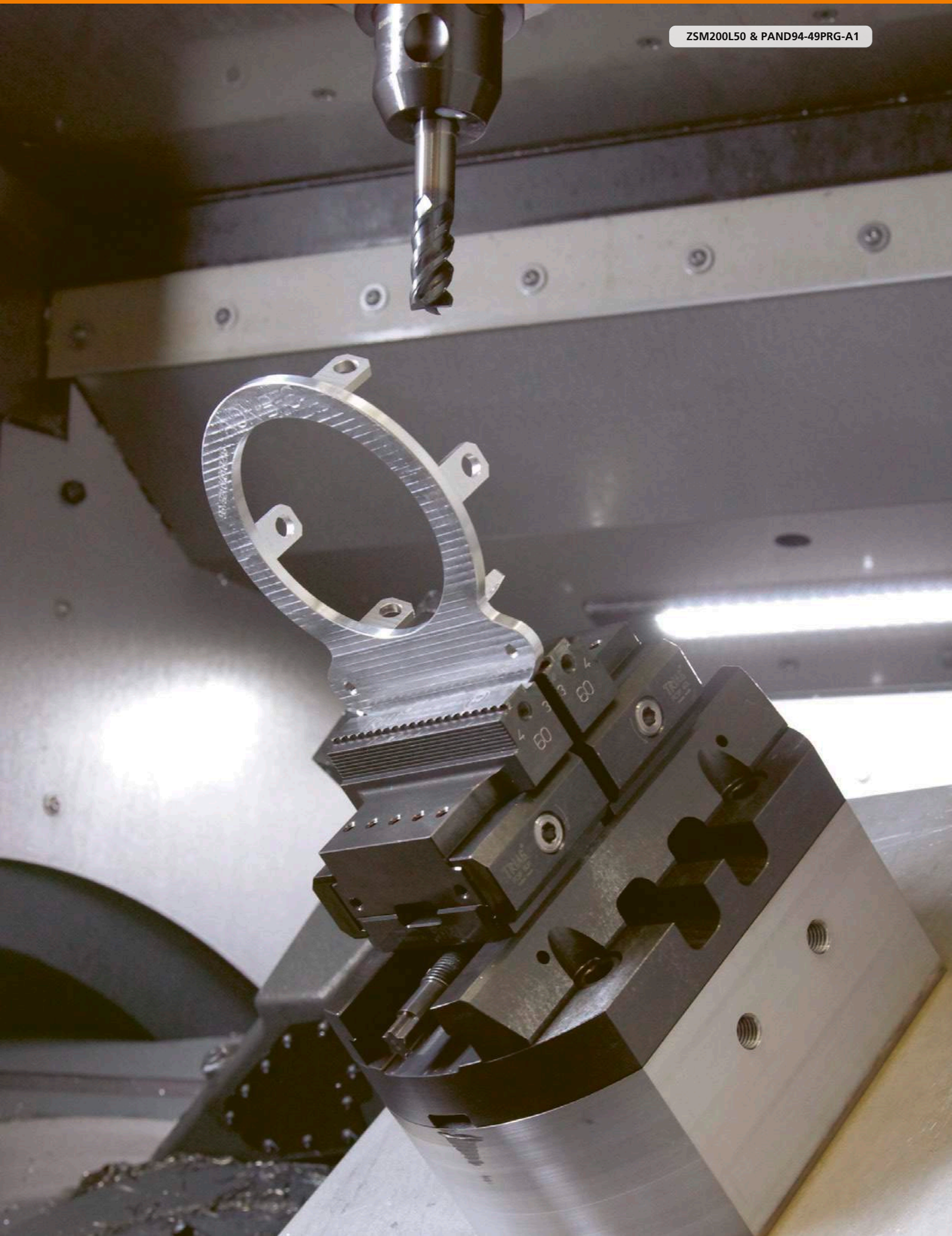

Direkt-Prägebacken

Bei knapp gespannten Werkstücken, speziell in weichen Materialien, wie Alu und Rostfrei aber auch in praktisch allen anderen Materialien, besteht das Problem, dass sich die Werkstücke freiwiegeln! Dies vor allem bei weit auskragenden Werkstücken bei der 5-Achsen Bearbeitung, selbst wenn vorgeprägt wird.

Triag International hat deshalb einen nachfedernden Zentrisch Spannstock entwickelt, welcher ein Freiwiegeln der Werkstücke mittels Nachfederung verhindert.

Bei diesem patentiertem System wird mittels Tellerfedern eine Backe des Zentrischspannstockes nachgeschoben. So wird der Spanndruck aufrechtgehalten. Die Einspanntiefe ist im Normalfall 3 mm, kann aber verstellt werden von ca. 1,8 bis 6 mm. Das Werkstück kann sich so praktisch nicht freiwiegeln.

Das heisst, man hat durchwegs die gleichen Bedingungen und das Werkstück hat während der Bearbeitung weniger Vibrationen und bewegt sich nicht. Oberfläche und Genauigkeit verbessern sich und sind konstanter.

Direct spring loaded stamping jaws

This patented self centering vise is unique, as it can be used for direct stamping the blanks. It is different to others as the teeth bite into the raw material and even under vibrations, one of the two jaws will continuously move forward. This will hold the workpiece with the same force and strength as in the beginning.

The problem in the past was that the other systems in the market were getting loose during heavy machining and accuracy was difficult to achieve.

Especially in soft materials such as alu and soft steels it has a great performance. Usually the workpiece is clamped only 3 mm but this height can be changed from 1,8 to 6 mm if necessary.

Spannkrafterhaltung und Nachfederung
Spring loaded mechanism to maintain clamping force

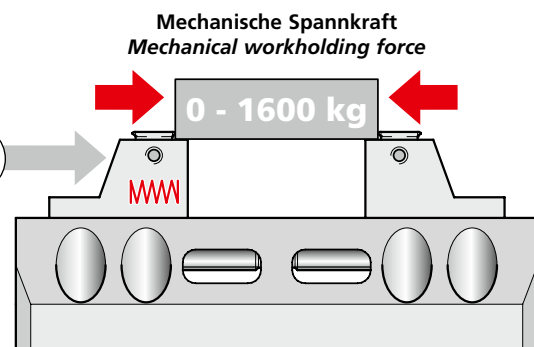

MANF58-14W25 **microCLAMP** p. 176

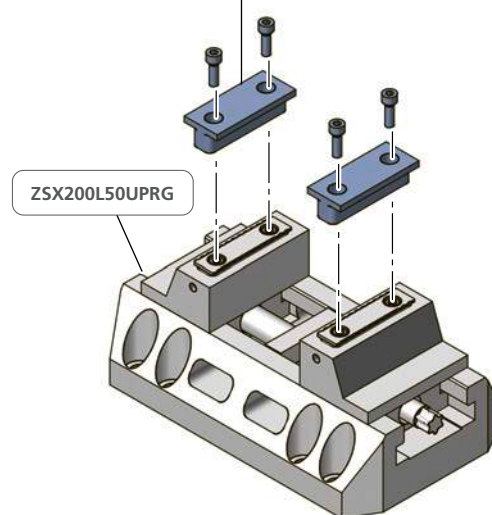

| Drehmoment Torque | | Spannkraft Workholding force | | | Gut zu Wissen Good to know |
|----------------------|---------|---------------------------------|-------|-----|---|
| Nm | (lb-ft) | ~daN | ~(lb) | ~t | |
| 10 | 7,4 | = 200 | 440 | 0,2 | Diese Spannkraften werden für den Dauerbetrieb empfohlen! <i>These clamping forces are recommended for continuous operation!</i> |
| 20 | 14,8 | = 500 | 1'102 | 0,5 | |
| 30 | 22,2 | = 1'000 | 2'204 | 1,0 | |
| 40 | 29,6 | = 1'300 | 2'866 | 1,3 | |
| 50 | 37,0 | = 1'600 | 3'527 | 1,6 | |
| 60 | 44,4 | = 1'800 | 3'968 | 1,8 | Für kurzfristige Anwendung <i>For short-term application</i> |
| 70 | 51,8 | = 2'100 | 4'629 | 2,1 | |

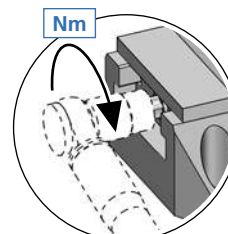

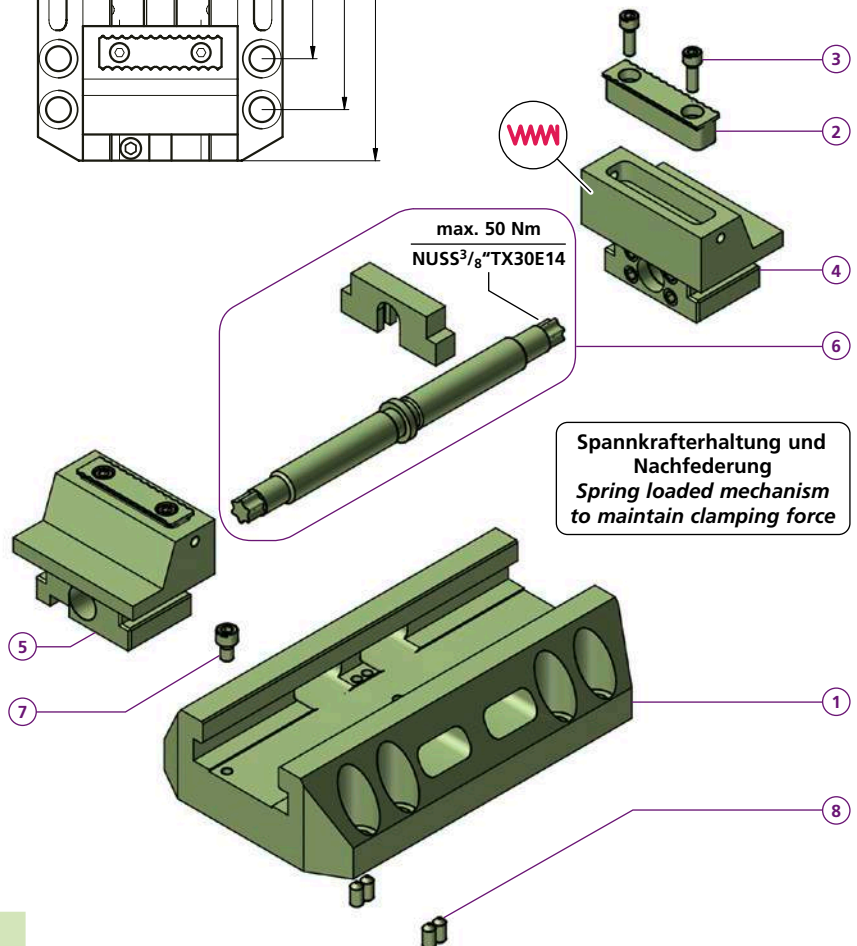
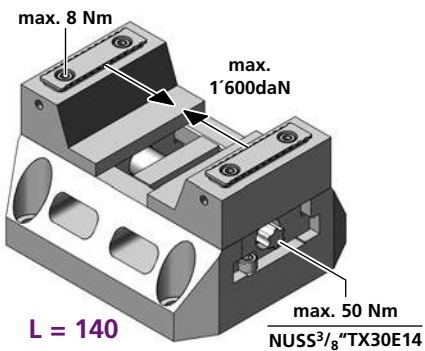
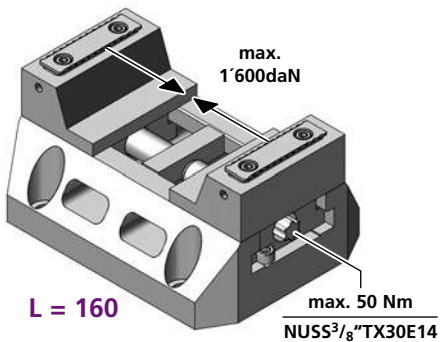
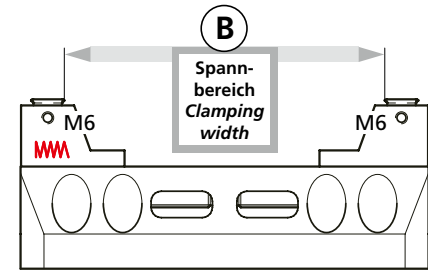
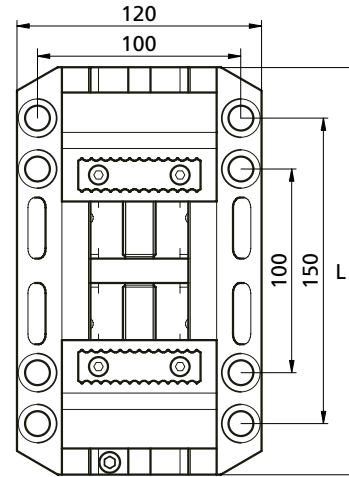
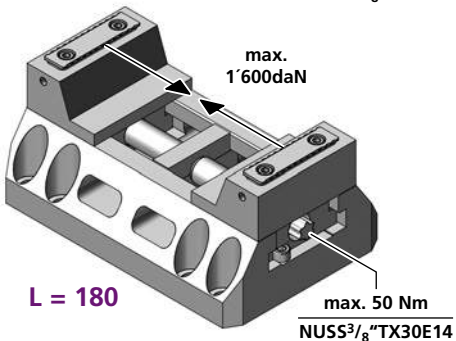
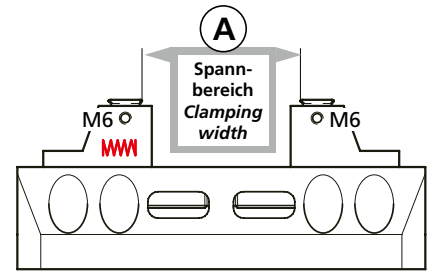
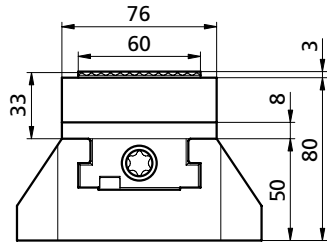
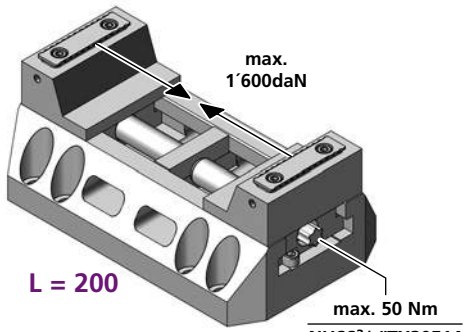

| ZSX200L50UPRG | |
|---------------|------------------|
| 1 | 1x TK150025 |
| 2 | 2x MAND58-14PRG |
| 3 | 4x M5X16ISO4762 |
| 4 | 1x ZB150787 |
| 5 | 1x ZB150786 |
| 6 | 1x PCS16TR200SET |
| 7 | 1x M6X10ISO4762 |
| 8 | 4x M6X16DIN914 |
| L | = 200 |
| A | 10 – 124 mm |
| B | 62 – 178 mm |
| kg | ~8,8 |

| ZSX180L50UPRG | |
|---------------|------------------|
| 1 | 1x TK150523 |
| 6 | 1x PCS16TR180SET |
| L | = 180 |
| A | 10 – 104 mm |
| B | 62 – 158 mm |
| kg | ~8,1 |

| ZSX160L50UPRG | |
|---------------|------------------|
| 1 | 1x TK150522 |
| 6 | 1x PCS16TR160SET |
| L | = 160 |
| A | 10 – 84 mm |
| B | 62 – 138 mm |
| kg | ~7,7 |

| ZSX140L50UPRG | |
|---------------|------------------|
| 1 | 1x TK150521 |
| 6 | 1x PCS16TR140SET |
| L | = 140 |
| A | 10 – 64 mm |
| B | 62 – 118 mm |
| kg | ~7,1 |

Drehmoment und Spannkraft siehe Seite 140
Torque and clamping force see page 140

NUSS3/8"TX30E14

WICHTIG!
Bitte separat bestellen
IMPORTANT!
Please order separately



Bestellbeispiel / Ordering example:
3 x ZSX200L50UPRG & 1 x NUSS3/8"TX30E14

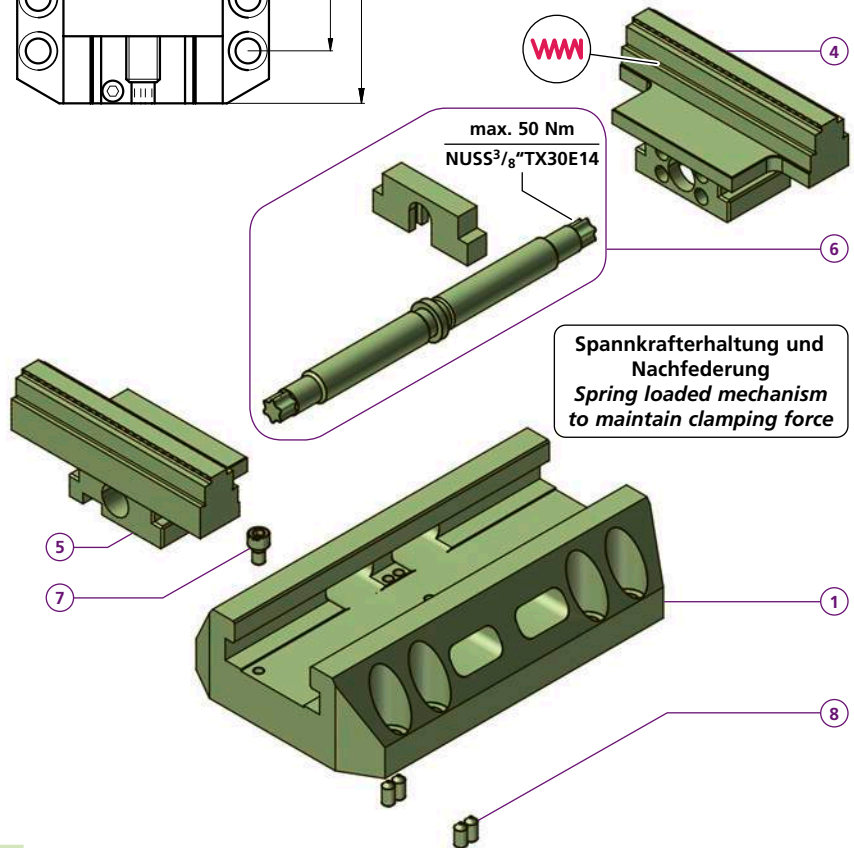
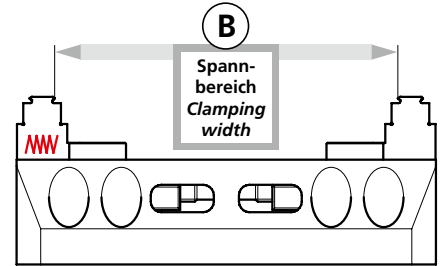
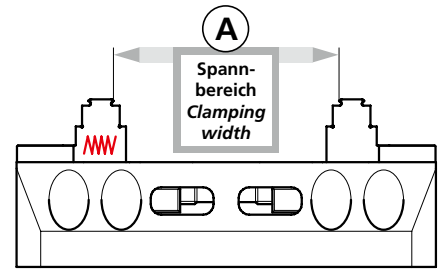
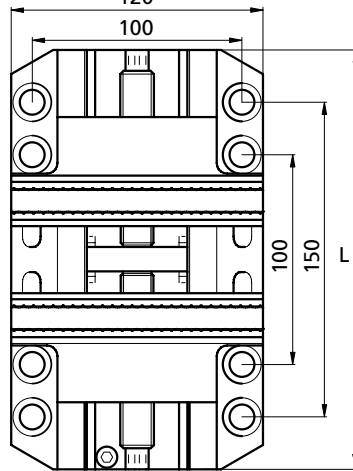
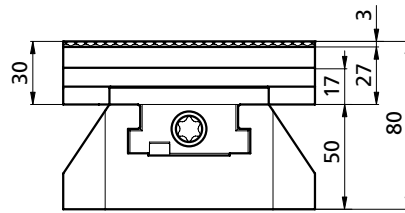
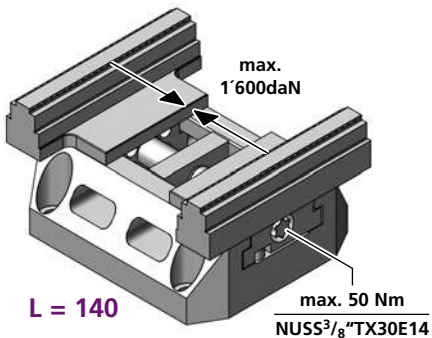
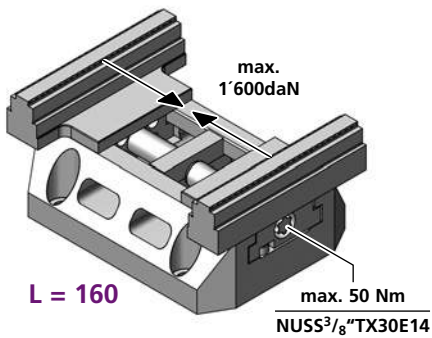
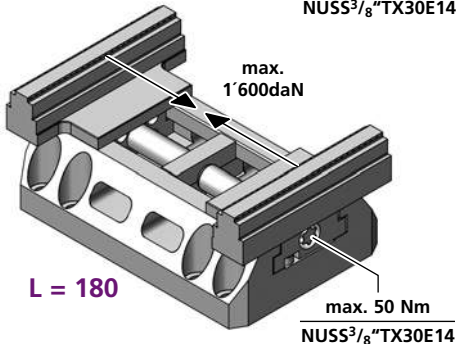
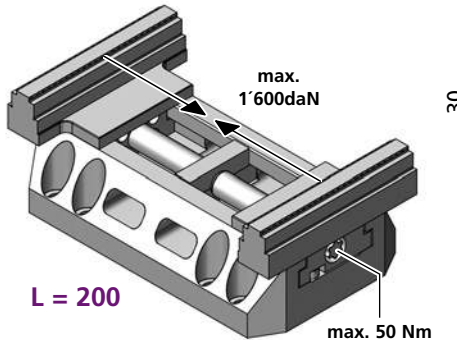

| ZSX200L50PRG120 | |
|-----------------|------------------|
| 1 | 1x TK150025 |
| 4 | 1x ZB170050 |
| 5 | 1x TB170051 |
| 6 | 1x PCS16TR200SET |
| 7 | 1x M6X10ISO4762 |
| 8 | 4x M6X16DIN914 |
| L | = 200 |
| A | 14 – 130 mm |
| B | 70 – 186 mm |
| kg | ~7,7 |

| ZSX180L50PRG120 | |
|-----------------|------------------|
| 1 | 1x TK150523 |
| 6 | 1x PCS16TR180SET |
| L | = 180 |
| A | 14 – 110 mm |
| B | 70 – 166 mm |
| kg | ~7,2 |

| ZSX160L50PRG120 | |
|-----------------|------------------|
| 1 | 1x TK150522 |
| 6 | 1x PCS16TR160SET |
| L | = 160 |
| A | 14 – 90 mm |
| B | 70 – 146 mm |
| kg | ~6,6 |

| ZSX140L50PRG120 | |
|-----------------|------------------|
| 1 | 1x TK150521 |
| 6 | 1x PCS16TR140SET |
| L | = 140 |
| A | 14 – 70 mm |
| B | 70 – 126 mm |
| kg | ~6,0 |

Drehmoment und Spannkraft siehe Seite 140
Torque and clamping force see page 140

NUSS3/8"TX30E14

WICHTIG!
Bitte separat bestellen
IMPORTANT!
Please order separately



Bestellbeispiel / Ordering example:
3 x ZSX200L50PRG120 & 1 x NUSS3/8"TX30E14

| Drehmoment Torque | | Spannkraft Workholding force | | | Gut zu Wissen Good to know |
|----------------------|---------|---------------------------------|-------|-----|---|
| Nm | (lb-ft) | ~daN | ~(lb) | ~t | |
| 10 | 7,4 | = 200 | 440 | 0,2 | Diese Spannkraften werden für den Dauerbetrieb empfohlen! <i>These clamping forces are recommended for continuous operation!</i> |
| 20 | 14,8 | = 500 | 1'102 | 0,5 | |
| 30 | 22,2 | = 1'000 | 2'204 | 1,0 | |
| 40 | 29,6 | = 1'300 | 2'866 | 1,3 | |
| 50 | 37,0 | = 1'600 | 3'527 | 1,6 | |
| 60 | 44,4 | = 1'800 | 3'968 | 1,8 | Für kurzfristige Anwendung <i>For short-term application</i> |
| 70 | 51,8 | = 2'100 | 4'629 | 2,1 | |

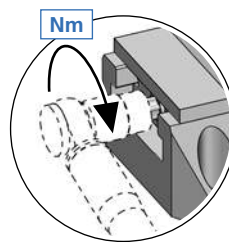

NEWS →

PowerCLAMP

Anschlagmodul mit Prägeeinsätzen
End modul with embossed inserts

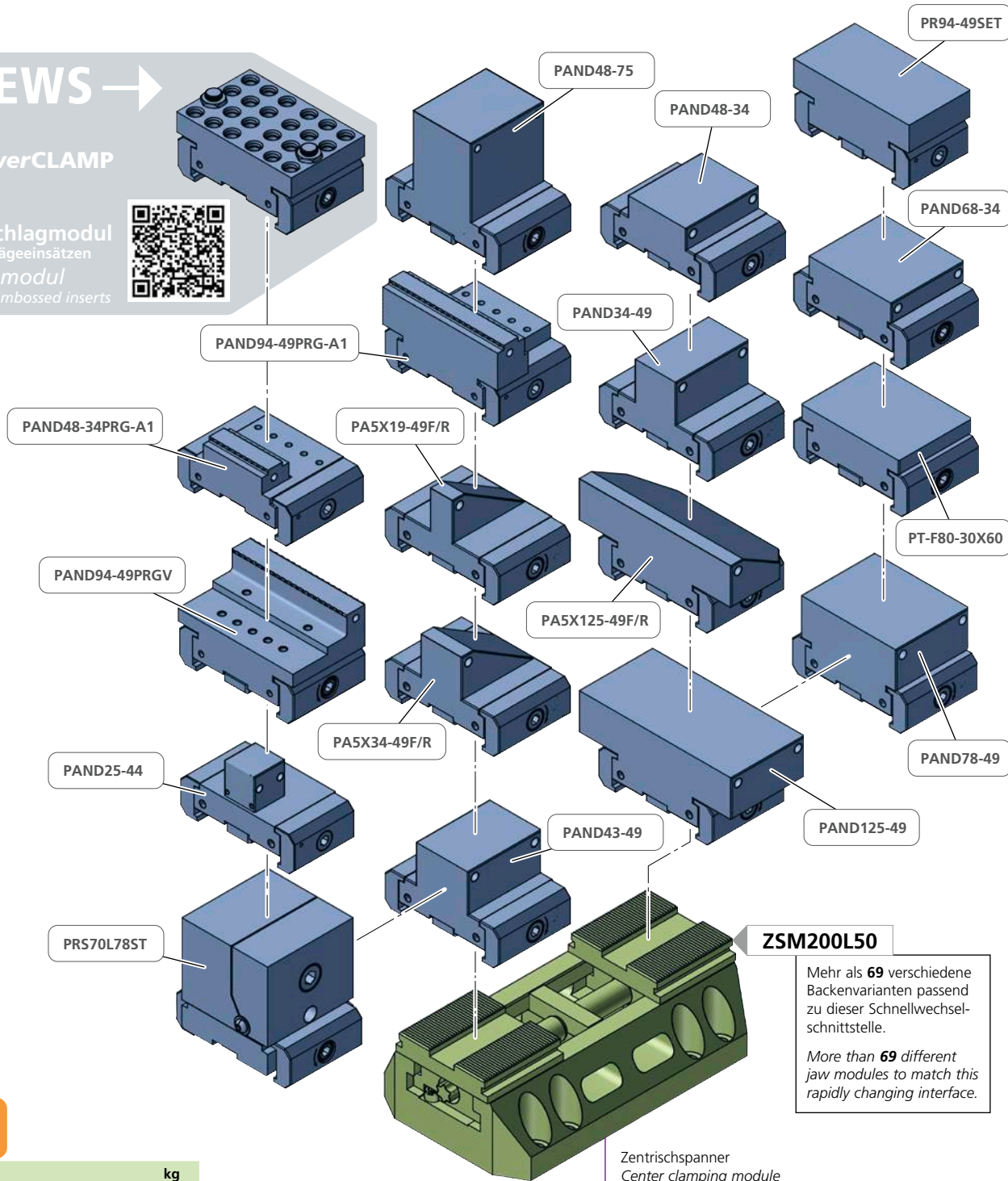

ZSM200L50

Mehr als 69 verschiedene Backenvarianten passend zu dieser Schnellwechelschnittstelle.

More than 69 different jaw modules to match this rapidly changing interface.

Zentrischspanner
Center clamping module



| | kg |
|-------------|------|
| 1 ZSM200L50 | ~5,6 |
| ZSM180L50 | ~5,0 |
| ZSM160L50 | ~4,5 |
| ZSM140L50 | ~4,0 |
| 2x | |

powerCLAMP p. 86 - 96

Bestellbeispiel / Ordering example: 1 x ZSM200L50 & 2 x PAND94-49PRG-A1

Zentrischspanner mit powerCLAMP Schnittstelle

Self centering vise with powerCLAMP interface

| Art. Nr. | A | B | kg | L |
|------------------|-------------|-------------|-------|-----|
| ZSM140L50 | 60 – 120 mm | 10 – 68 mm | ~5,7 | 140 |
| ZSM160L50 | 60 – 140 mm | 10 – 88 mm | ~6,4 | 160 |
| ZSM180L50 | 60 – 160 mm | 10 – 108 mm | ~6,9 | 180 |
| ZSM200L50 | 60 – 180 mm | 10 – 128 mm | ~7,4 | 200 |
| ZSM300L50 | 60 – 280 mm | 10 – 228 mm | ~10,5 | 300 |

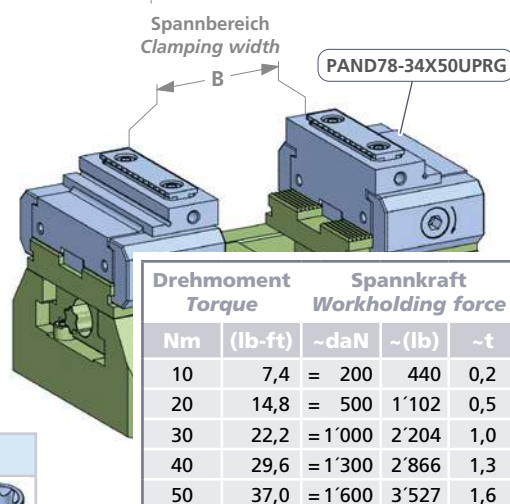
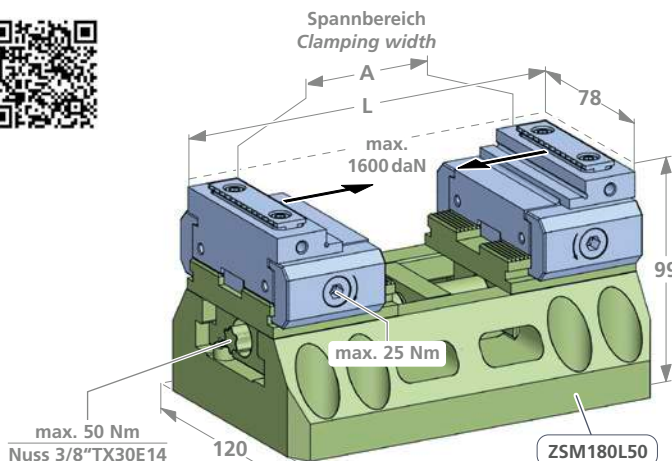
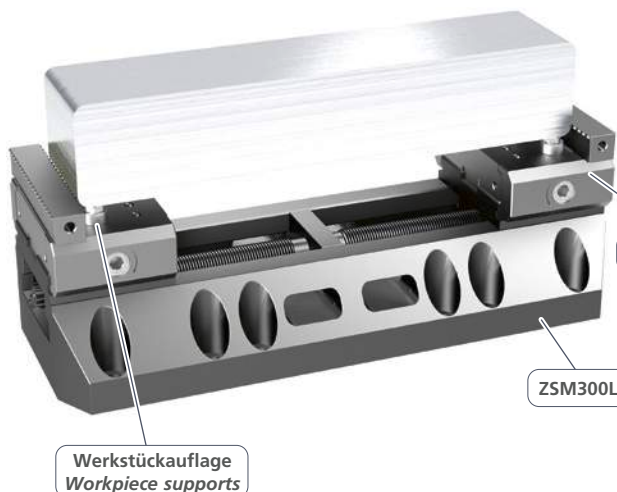

Mehr als 60 verschiedene Backenvarianten passend zu dieser Schnellwechselschnittstelle.
More than 60 different jaw modules to match this rapidly changing interface.

NUSS3/8"TX30E14

WICHTIG!
Bitte separat bestellen
IMPORTANT!
Please order separately

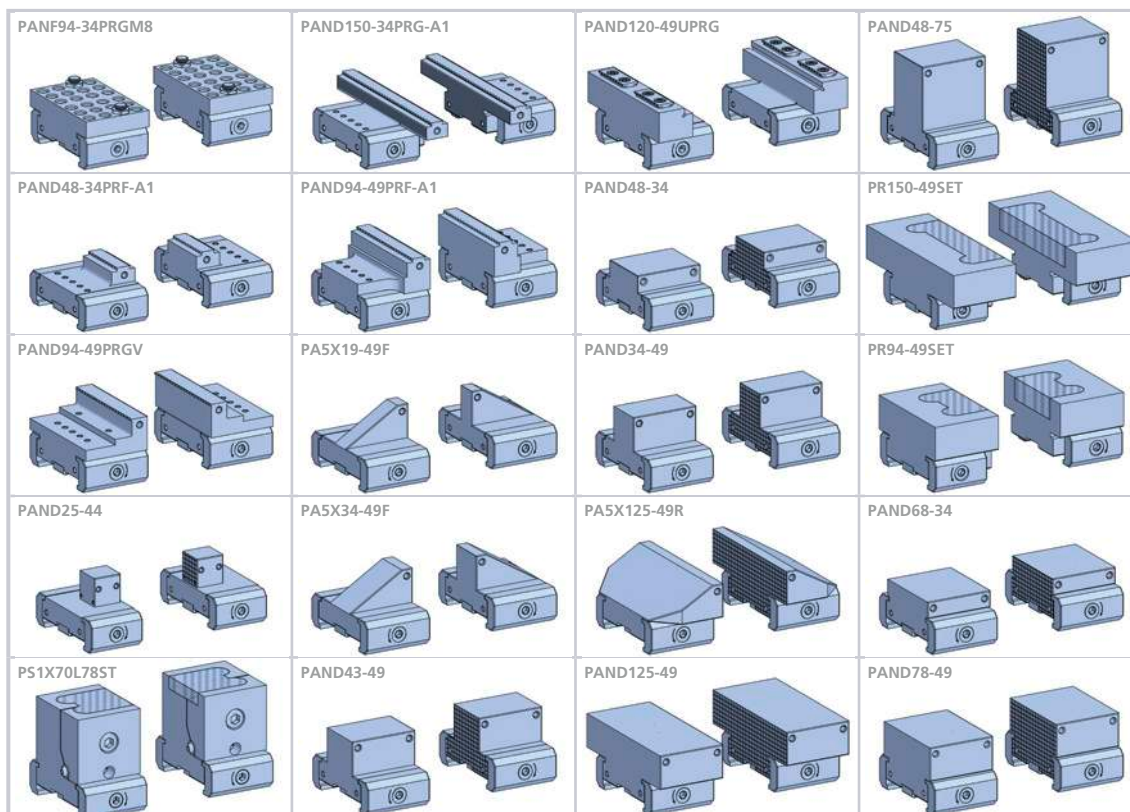

Seitlich verstellbarer Zentrischspannstock

Passend auf alle Power Clamp Basisschienen können mehrere dieser Zentrischspanner, seitlich aneinander gereiht, lange Werkstücke spannen und sind dabei flexibel in 2 mm Schritten seitlich verschiebbar.

Auch können diese für Mehrfachspannung genutzt werden und mehrere Einzelteile an fixen Punkten gespannt werden.

Einsatzgebiet für lange Profile, Stangen und Bleche aber auch Mehrfachspannung von fast allen Materialien.

Laterally adjustable centric vise

Fitting all Power Clamp basic rails, several of these self-centering vices can, arranged laterally in rows, clamp long work pieces and can hereby be flexibly shifted sideways in 2 mm steps.

They can also be used for multi clamping and several individual parts clamped at fixed points.

The field of application for long sections, rods and sheets but also multi clamping of almost all materials.

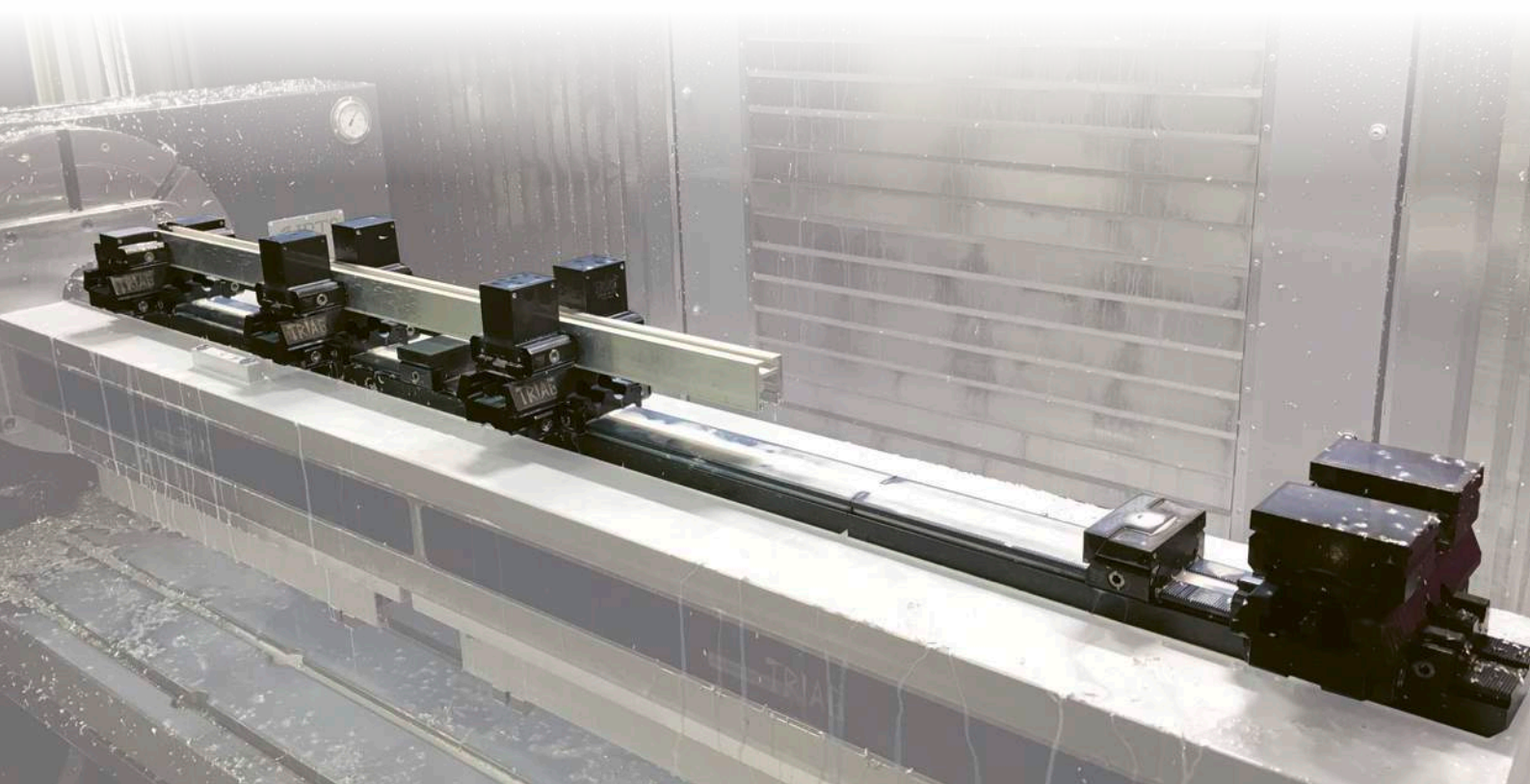
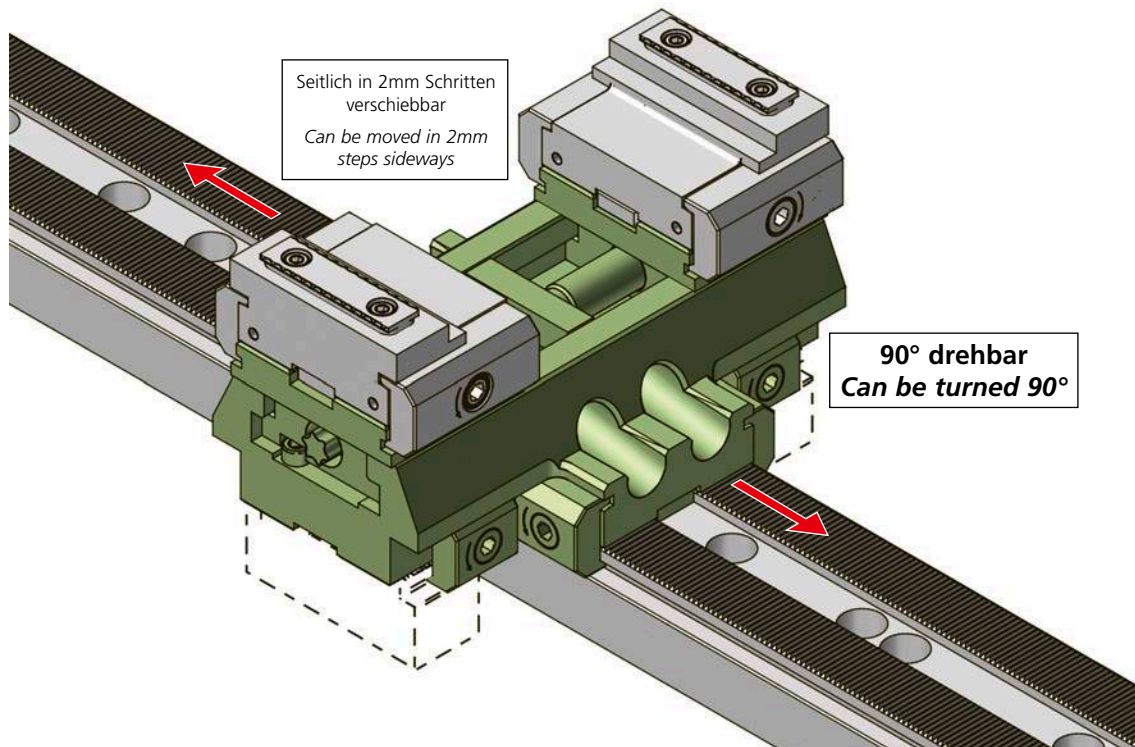

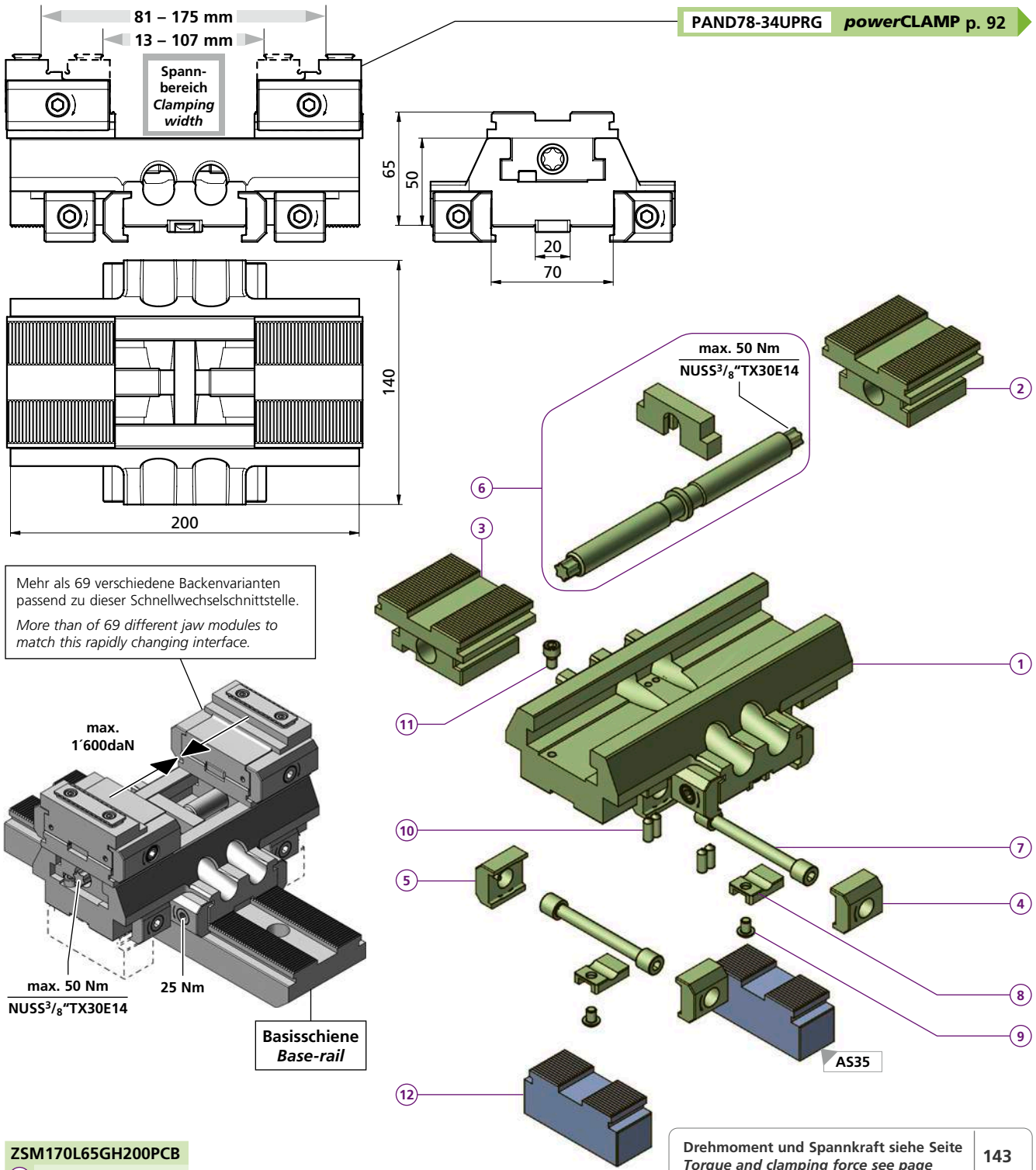

Mehr als 69 verschiedene Backenvarianten passend zu dieser Schnellwechselschnittstelle.
More than of 69 different jaw modules to match this rapidly changing interface.

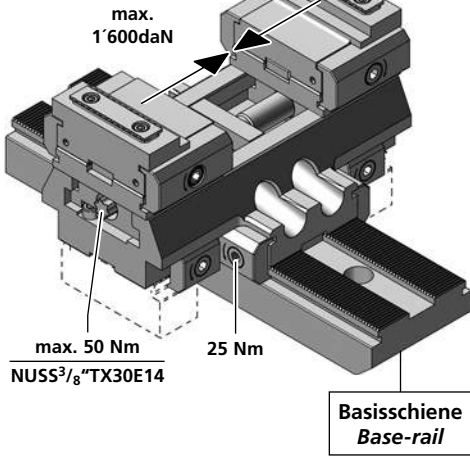

Drehmoment und Spannkraft siehe Seite 143
Torque and clamping force see page 143

- ZSM170L65GH200PCB**
- 1 1x TB140566
 - 2 1x TB150092
 - 3 1x TB150091
 - 4 4x PCSP30L
 - 5 4x PCSP30R
 - 6 1x PCS16TR200SET
 - 7 4x PCS14
 - 8 4x PCGU2030
 - 9 4x M6X8ISO7380
 - 10 4x M6X16DIN914
 - 11 1x M6X10ISO4762
 - 12 2x
- kg ~8,6

Schienehöhe / Rail height

| AS35 (H = 35) | AS60 (H = 60) | AS80 (H = 80) |
|------------------|------------------|------------------|
| | | |

NUSS3/8\"TX30E14
WICHTIG!
Bitte separat bestellen
IMPORTANT!
Please order separately

Seitliche Stützen / Side support
Bei Gebrauch dieses Zentrischspanners, werden je nach Höhe der Basisschiene auf dessen sie aufgesetzt wird, zwei seitliche Stützen AS35 / AS60 / AS80 unterlegt.
When using this self centering vise, a side support AS35 / AS60 / AS80 is underlaid, depending on the height of the base rail on which it is placed.

Bestellbeispiel / Ordering example: 2 x ZSM170L65GH200PCB & 4 x AS35 & 1 x NUSS3/8\"TX30E14

Separat bestellen / Order separately

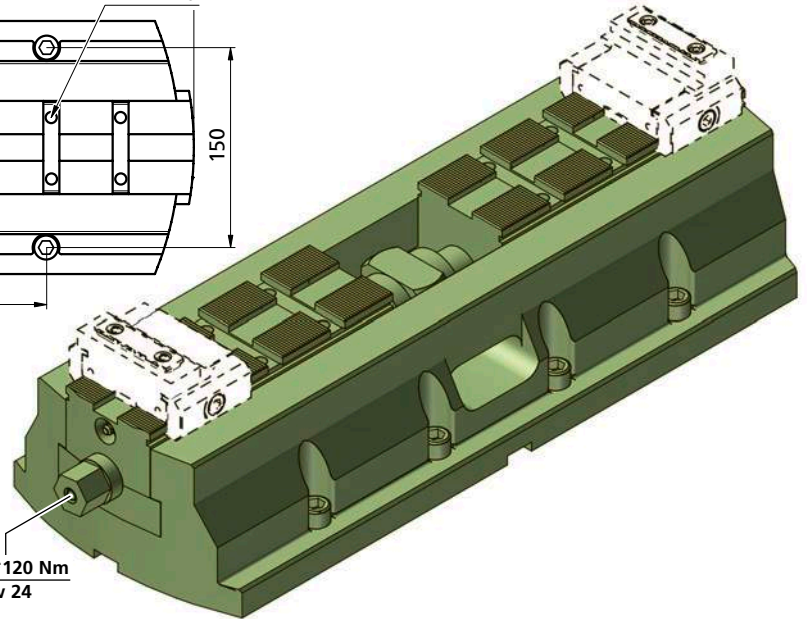
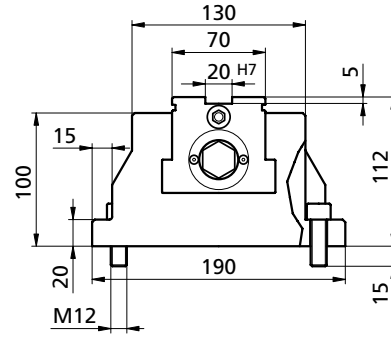
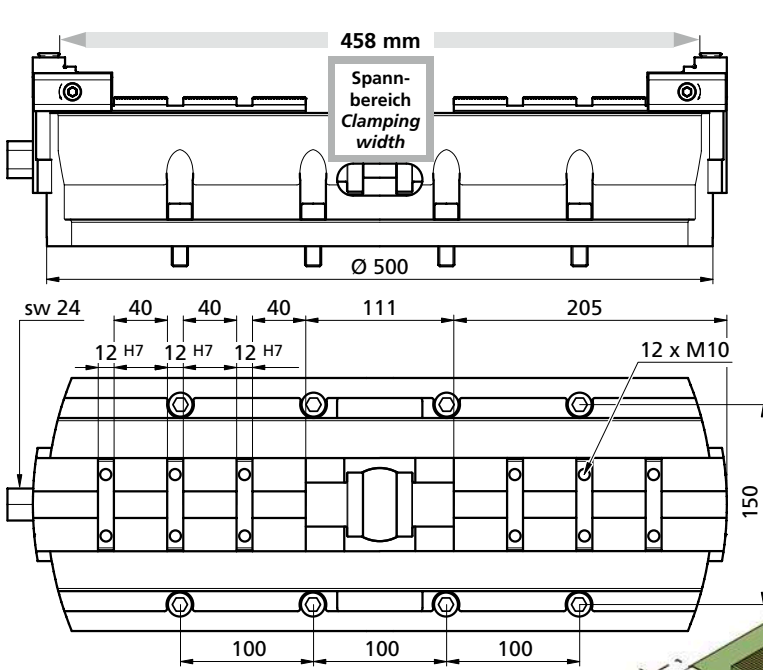

ZSMB500L112 kg = ~59
Backenhub (pro Backe)
Stroke of clamping (each jaw)
 55 mm

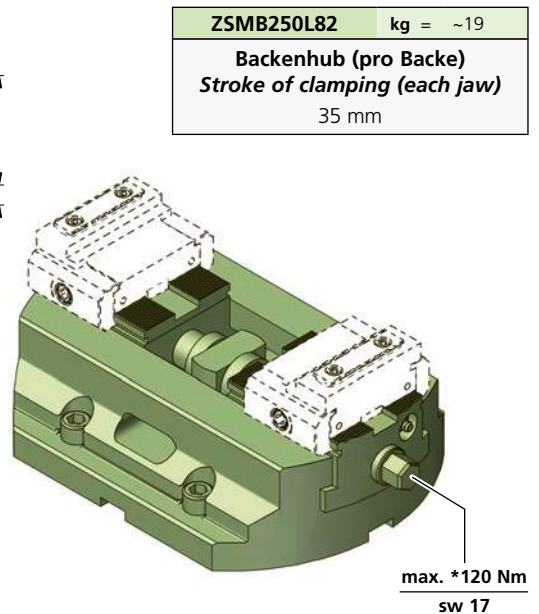
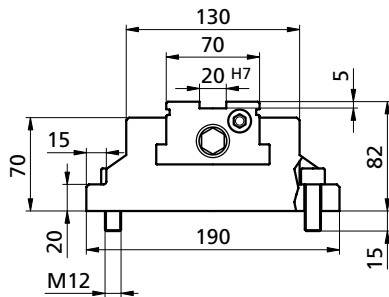
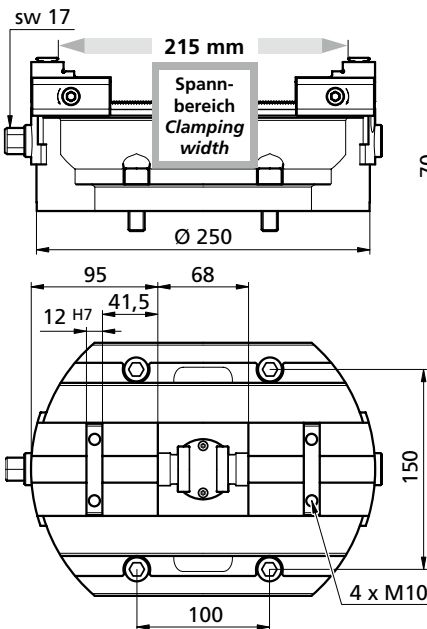

ZSMB250L82 kg = ~19
Backenhub (pro Backe)
Stroke of clamping (each jaw)
 35 mm

| Drehmoment Torque | | Spannkraft Workholding force | | | <p>Gut zu Wissen Good to know</p> <p>Diese Spannkraften werden für den Dauerbetrieb empfohlen! These clamping forces are recommended for continuous operation!</p> <p>Für kurzfristige Anwendung For short-term application</p> |
|----------------------|---------|---------------------------------|-------|-----|--|
| Nm | (lb-ft) | ~daN | ~(lb) | ~t | |
| 40 | 29,5 | = 800 | 1798 | 0,8 | |
| 60 | 44,26 | = 1200 | 2697 | 1,2 | |
| 80 | 59 | = 1600 | 3597 | 1,6 | |
| 100 | 73,75 | = 2000 | 4496 | 2 | |
| *120 | 88,5 | = 2400 | 5395 | 2,4 | |

! Für längerfristige Anwendung ab 140 – 250 Nm müssen **geschraubte Backen** eingesetzt werden!
 For longer-term use from 140 – 250 Nm the **screwed jaws** must be used!

Bestellbeispiel / Ordering example : ZSMB500L112

Zentrischspanner mit Schnellwechselbacken

Self centering vise with quick-change jaws

Zentrischspanner mit Spannkrafterhaltung und Nachfederung
Self centering vise with spring loaded mechanism to maintain clamping force

| Art. Nr. | www | A mm | B mm | C mm | | kg |
|----------------|----------|----------|------|---------|---------------|--------|
| ZSQP300L50UPRG | 80 – 260 | | | 8 – 188 | $\pm 3^\circ$ | ~11,10 |
| ZSQ200L50UPRG | 80 – 160 | 44 – 124 | | 8 – 88 | | ~8,1 |
| ZSQP200L50UPRG | 80 – 160 | 44 – 124 | | 8 – 88 | $\pm 3^\circ$ | ~8,1 |
| ZSQ180L50UPRG | 80 – 140 | 44 – 104 | | 8 – 68 | | ~7,55 |
| ZSQP180L50UPRG | 80 – 140 | 44 – 104 | | 8 – 68 | $\pm 3^\circ$ | ~7,5 |
| ZSQ160L50UPRG | 80 – 120 | 44 – 84 | | 8 – 48 | | ~7,1 |
| ZSQP160L50UPRG | 80 – 120 | 44 – 84 | | 8 – 48 | $\pm 3^\circ$ | ~7,0 |

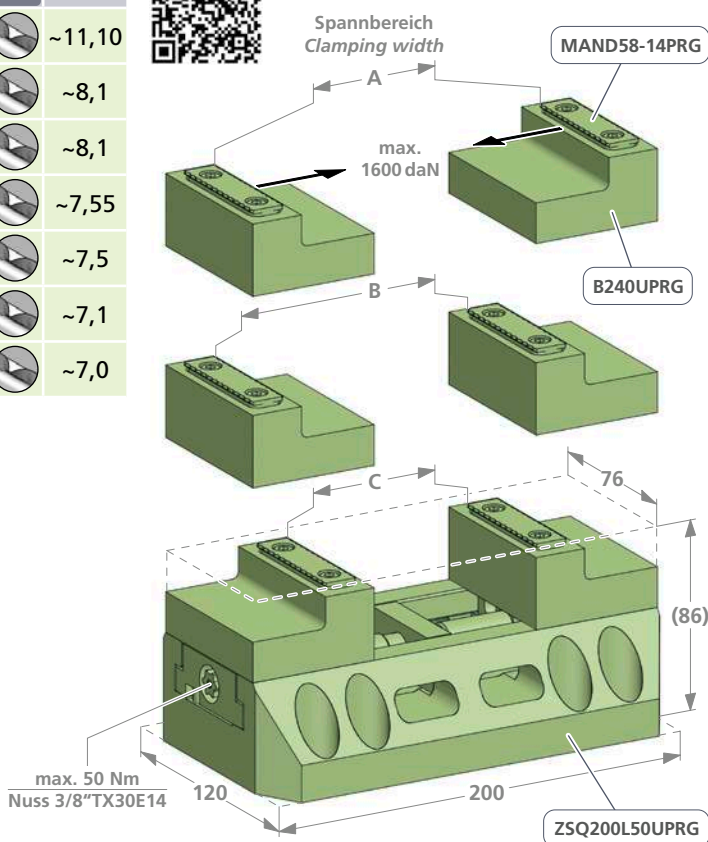

Für die Montage der Backen B240UPRG wird kein Werkzeug benötigt, diese werden per Hand auf dem Spanner eingeklinkt.

No tools are required for mounting the B240UPRG jaws, which are clipped onto the clamp by hand.

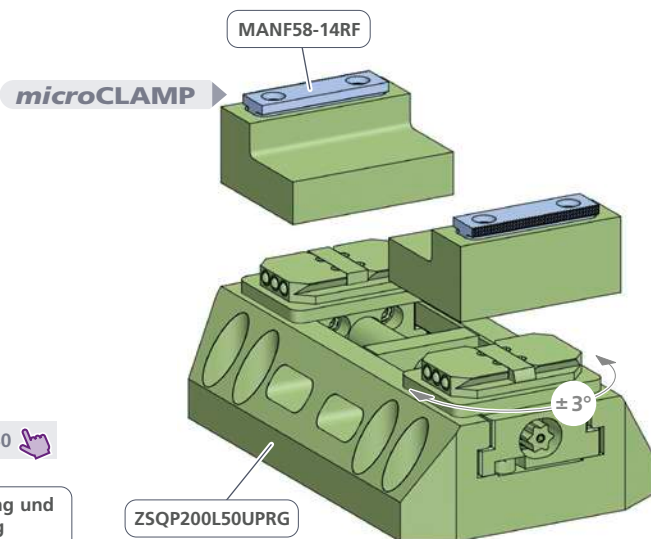

| Drehmoment Torque | | Spannkraft Workholding force | | |
|----------------------|---------|---------------------------------|-------|-----|
| Nm | (lb-ft) | ~daN | ~(lb) | ~t |
| 10 | 7,4 | = 200 | 440 | 0,2 |
| 20 | 14,8 | = 500 | 1'102 | 0,5 |
| 30 | 22,2 | = 1'000 | 2'204 | 1,0 |
| 40 | 29,6 | = 1'300 | 2'866 | 1,3 |
| 50 | 37,0 | = 1'600 | 3'527 | 1,6 |

NUSS3/8"TX30E14

WICHTIG!
Bitte separat bestellen
IMPORTANT!
Please order separately



Zentrischspanner mit Schnellwechselbacken

Self centering vise with quick-change jaws

Typ **Q**

triCENTRO

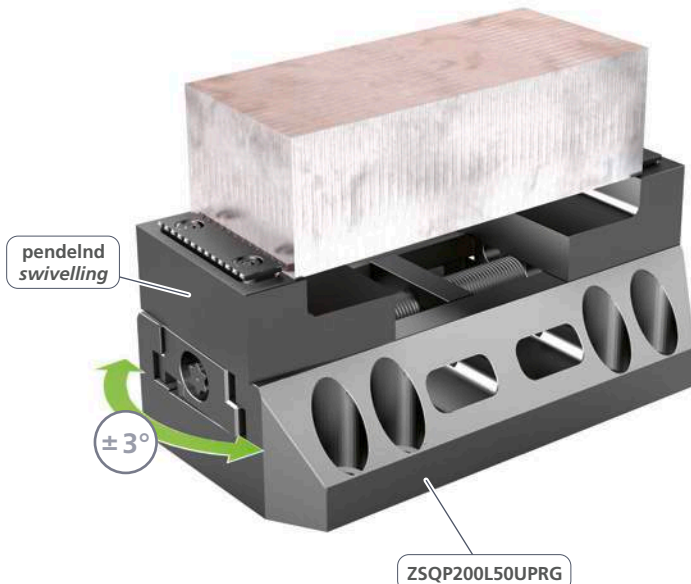

Mit diesen Zentrischspannern sind Ihre Werkstücke in festem Griff.
With these self centering vises your workpieces are in a firm grip.

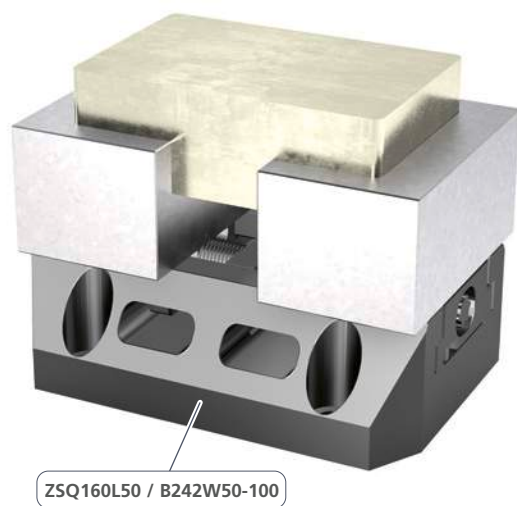

Spannbacke / Clamping jaw

| | | |
|----------|---|-----------------|
| Art. Nr. | B242W50-100 | B240UPRG |
| | Vergütungsstahl Tempering steel (1.7225) | 57HRC |
| kg | ~2 | ~0,52 |
| | | |

Weich, zur Herstellung individueller Formbacken. / Soft, for the production of individual moulding jaw.

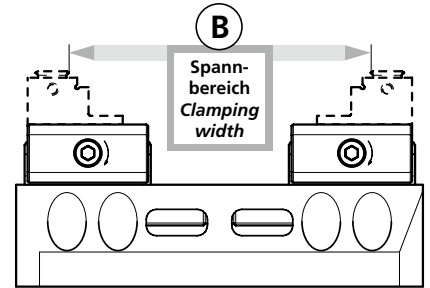
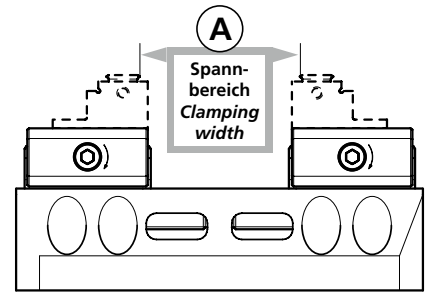
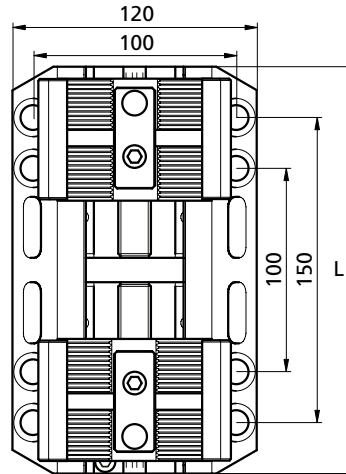
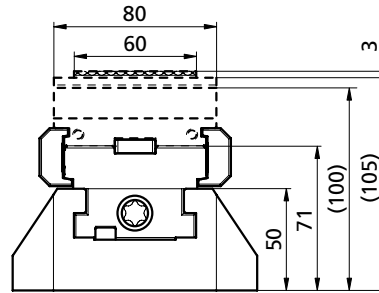
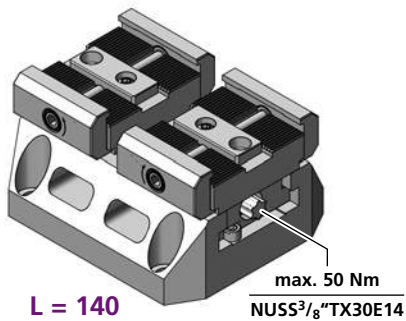
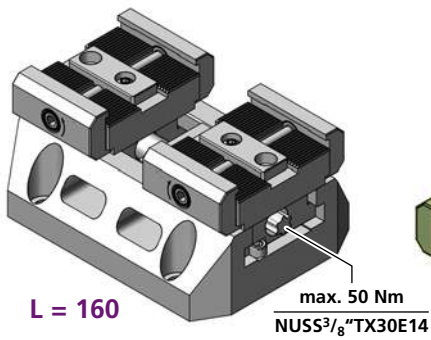
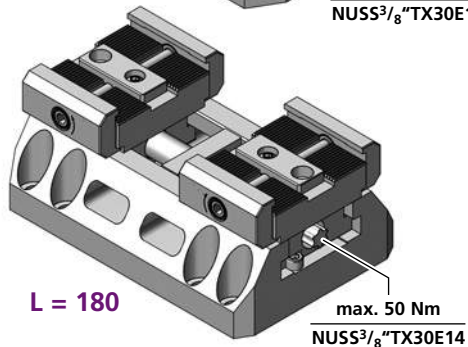
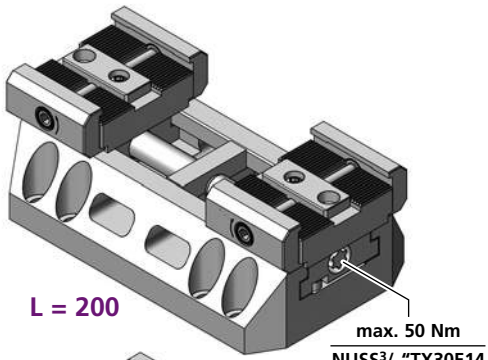

PCZB8050UPRG p. 152

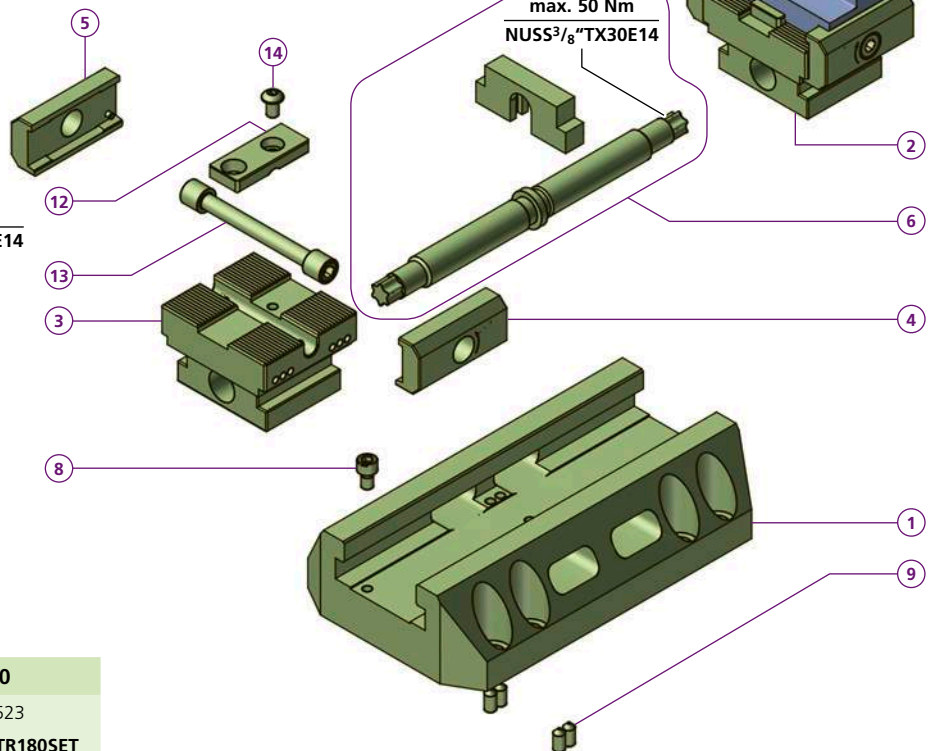

ZSB200L50

| | |
|----|------------------|
| 1 | 1x TK150025 |
| 2 | 1x ZB150791 |
| 3 | 1x ZB150792 |
| 4 | 2x PCSP60RG |
| 5 | 2x PCSP60LG |
| 6 | 1x PCS16TR200SET |
| 8 | 1x M6X10ISO4762 |
| 9 | 4x M6X16DIN914 |
| 12 | 2x PCGU2049 |
| 13 | 2x PCS14 |
| 14 | 2x M6X8ISO7380 |
| L | = 200 |
| A | 10 - 126 mm |
| B | 58 - 174 mm |
| kg | ~8,4 |

ZSB180L50

| | |
|----|------------------|
| 1 | 1x TK150523 |
| 6 | 1x PCS16TR180SET |
| L | = 180 |
| A | 10 - 104 mm |
| B | 58 - 154 mm |
| kg | ~7,9 |

ZSB160L50

| | |
|----|------------------|
| 1 | 1x TK150522 |
| 6 | 1x PCS16TR160SET |
| L | = 160 |
| A | 10 - 86 mm |
| B | 58 - 134 mm |
| kg | ~7,4 |

ZSB140L50

| | |
|----|------------------|
| 1 | 1x TK150521 |
| 6 | 1x PCS16TR140SET |
| L | = 140 |
| A | 10 - 65 mm |
| B | 58 - 113 mm |
| kg | ~6,7 |

Drehmoment und Spannkraft siehe Seite 151
Torque and clamping force see page 151

NUSS^{3/8}"TX30E14

WICHTIG!
Bitte separat bestellen
IMPORTANT!
Please order separately



Bestellbeispiel / Ordering example: 3 x ZSB200L50 & 6 x PCZB8050UPRG & 1 x NUSS^{3/8}"TX30E14

| Drehmoment Torque | | Spannkraft Workholding force | | | Gut zu Wissen Good to know |
|----------------------|---------|---------------------------------|-------|-----|---|
| Nm | (lb-ft) | ~daN | ~(lb) | ~t | |
| 10 | 7,4 | = 200 | 440 | 0,2 | Diese Spannkraften werden für den Dauerbetrieb empfohlen! <i>These clamping forces are recommended for continuous operation!</i> |
| 20 | 14,8 | = 500 | 1'102 | 0,5 | |
| 30 | 22,2 | = 1'000 | 2'204 | 1,0 | |
| 40 | 29,6 | = 1'300 | 2'866 | 1,3 | |
| 50 | 37,0 | = 1'600 | 3'527 | 1,6 | |
| 60 | 44,4 | = 1'800 | 3'968 | 1,8 | Für kurzfristige Anwendung <i>For short-term application</i> |
| 70 | 51,8 | = 2'100 | 4'629 | 2,1 | |

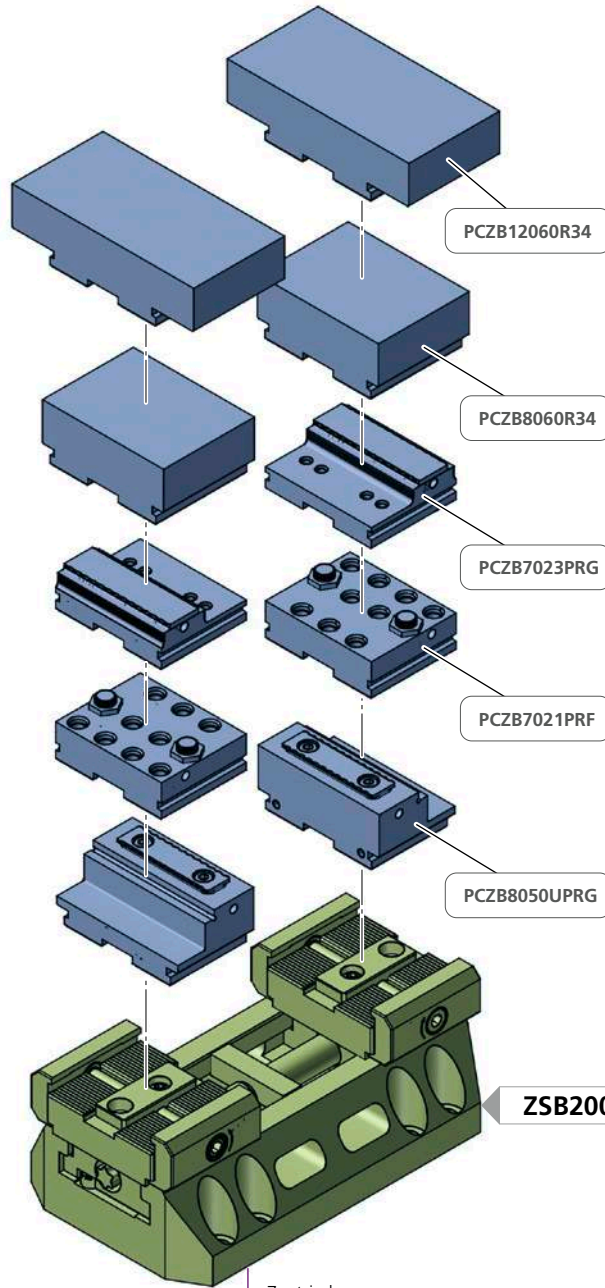
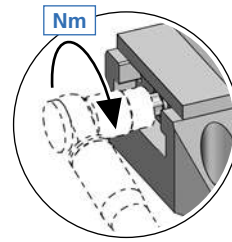

Mehr als **8** verschiedene Backenvarianten passend zu dieser Schnellwechsellchnittstelle.
More than 8 different jaw modules to match this rapidly changing interface.

B

| | kg |
|-------------|------|
| 1 ZSB200L50 | ~8,4 |
| ZSB180L50 | ~7,9 |
| ZSB160L50 | ~7,4 |
| ZSB140L50 | ~6,7 |
| 2x | |

p. 152

Bestellbeispiel / Ordering example: 1 x ZSM200L50 & 2 x PCZB8050UPRG

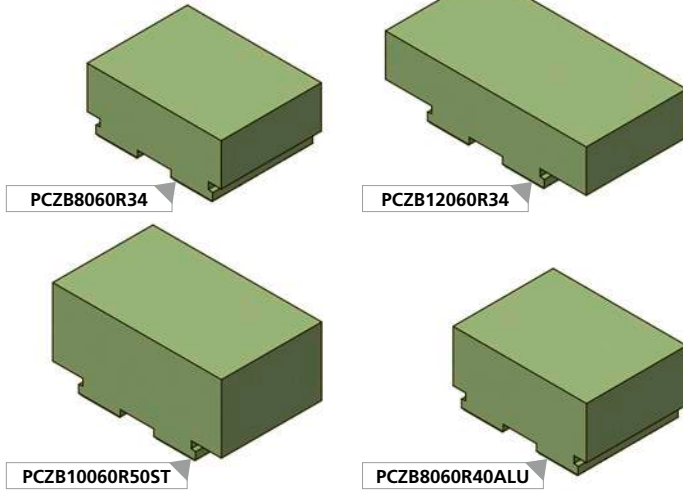
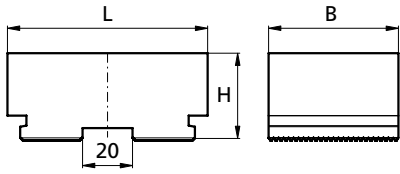

| | | L | B | H | kg |
|-----------------------|---------------|-----|----|----|-------|
| PCZB8060R34 | (Stahl/Steel) | 80 | 60 | 34 | ~1,2 |
| PCZB12060R34 | (Stahl/Steel) | 120 | 60 | 34 | ~1,7 |
| PCZB10060R50ST | (Stahl/Steel) | 101 | 60 | 50 | ~2,2 |
| PCZB8060R40ALU | ALU | 80 | 60 | 40 | ~0,52 |
| PCZB10060R50 | ALU | 101 | 60 | 50 | ~0,76 |

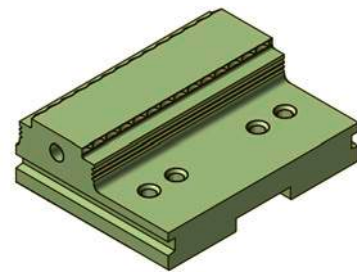
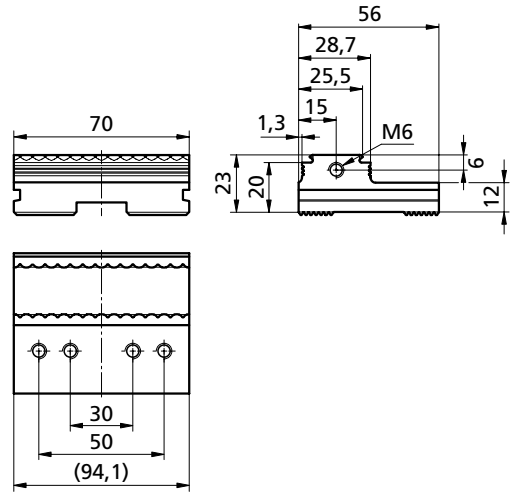

PCZB7023PRG kg ~0,54

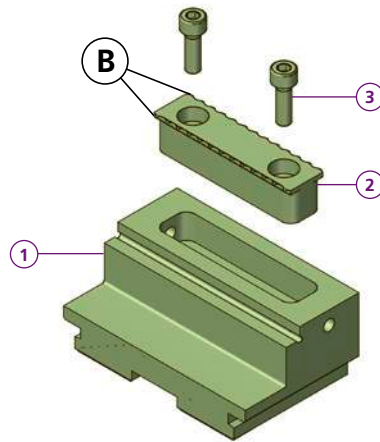

PCZB8050UPRG

- ① 1x TB161200
- ② 1x MAND58-14PRG
- ③ 1x M5X16ISO4762

kg ~0,75

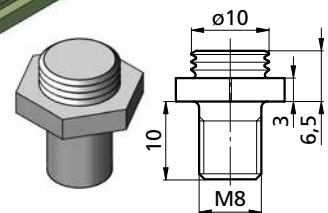
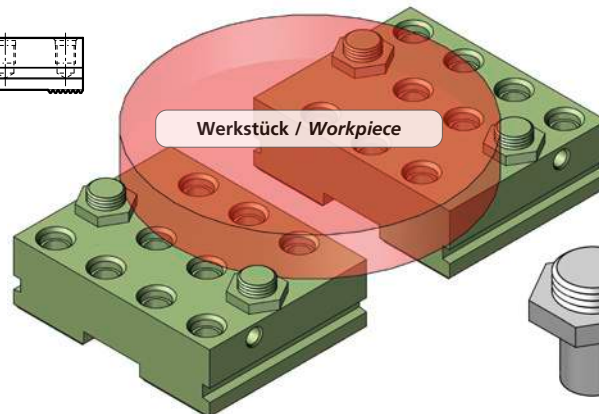
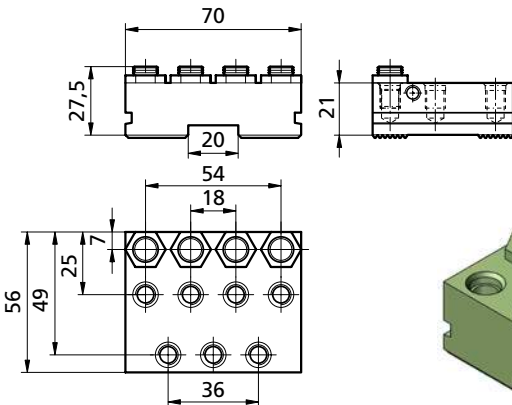
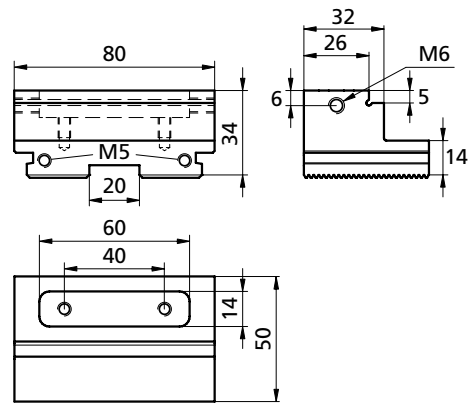

PCZB7021PRF kg ~0,6

PRG1003M8

Bestellbeispiel / Ordering example: 2 x **PCZB7021PRF** & 4 x **PRG1003M8**

spaceGRIP III

Spannbereich bis 180 mm, Spannkraft bei 70 Nm, 2,1 t/2100 daN. Hier kommen die «Grossen» unserer Zentrischspanner zum Einsatz. Speziell ist der Aufbau auf einer Stahl-Mineralgusspyramide um beste Verhältnisse bezüglich Vibrationsdämpfung zu bieten. Die Zentrischspanner dazu gibt es in vier Gehäuselängen (140, 160, 180 und 200 mm) und bis zu 60 Backenvarianten.

spaceGRIP III

Spans of up to 180 mm, clamping force at 70 Nm, 2.1 t/2100 daN. Here the «big ones» of our self-centering vices go into action. And there is the special setup of a steel mineral casting pyramid to provide the best conditions for vibration dampening. The self-centering vice for this is available with four housing lengths (140, 160, 180 and 200 mm) and up to 60 jaw versions.

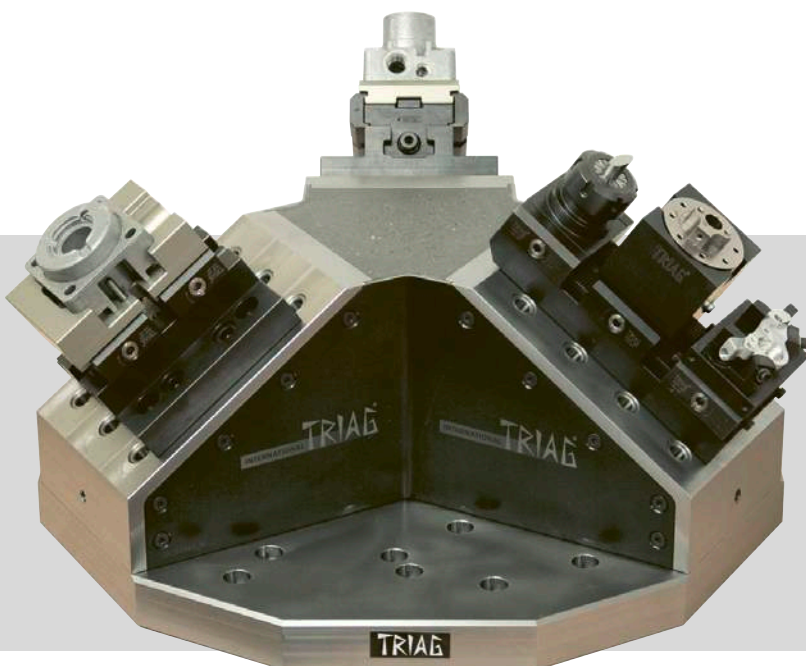

SPACEGRIP III

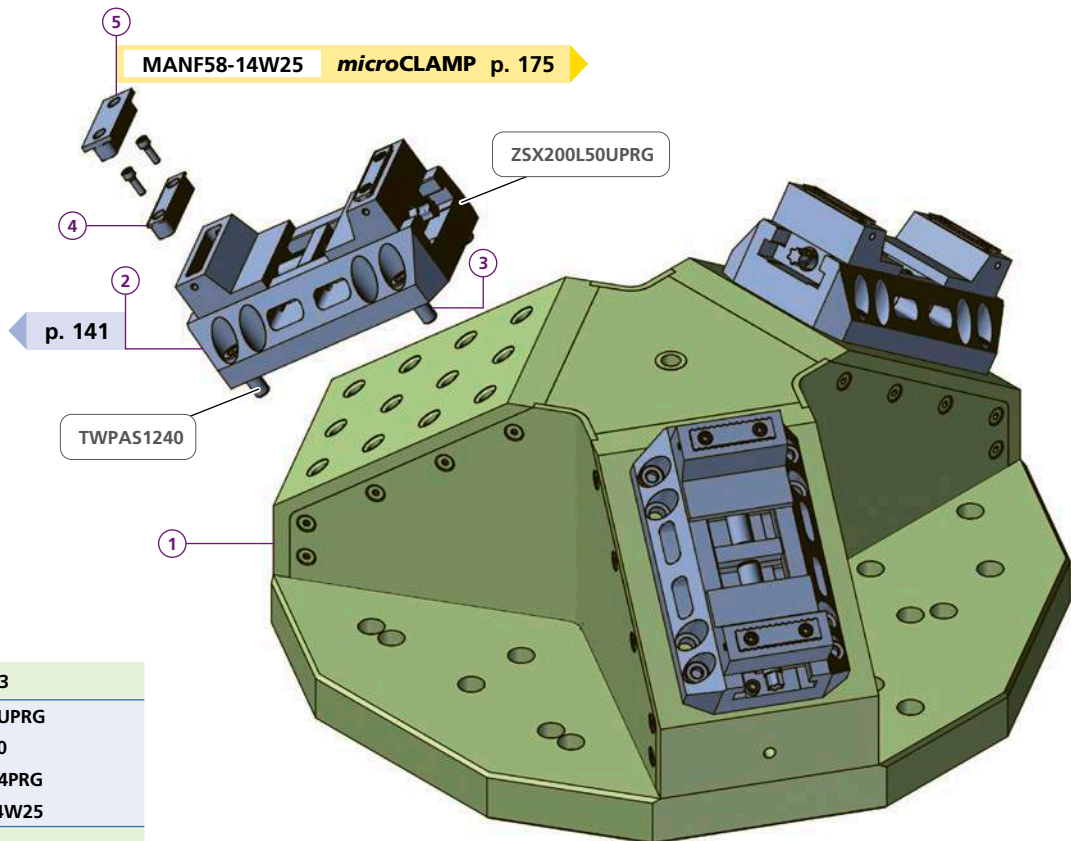
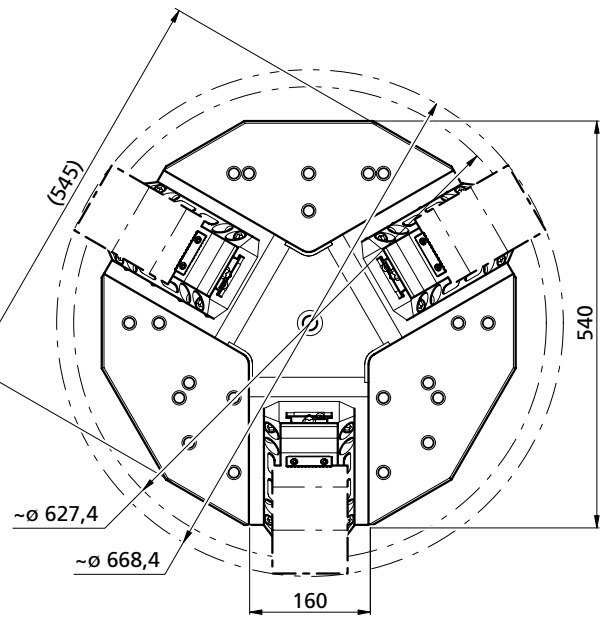
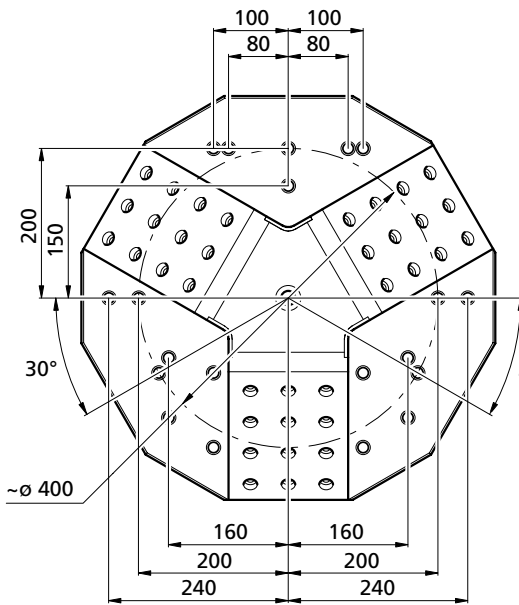
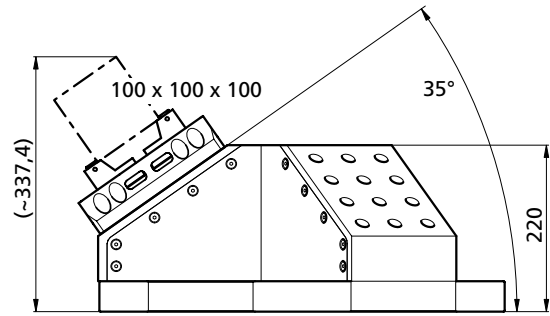
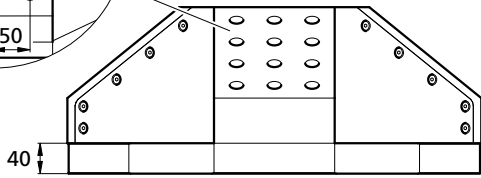
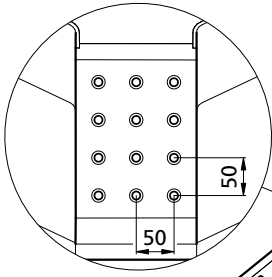

| | | |
|---|-----|---------------|
| 1 | 1x | 5AXZSX35-3 |
| 2 | 3x | ZSX200L50UPRG |
| 3 | 12x | TWPAS1240 |
| 4 | 6x | MANF58-14PRG |
| 5 | 6x | MANF58-14W25 |
| | | kg ~135 |

Bestellbeispiel / Ordering example: 1 x 5AXZSX35-3 & 3 x ZSX200L50UPRG & 6 x MANF58-14W25

Separat bestellen / Order separately

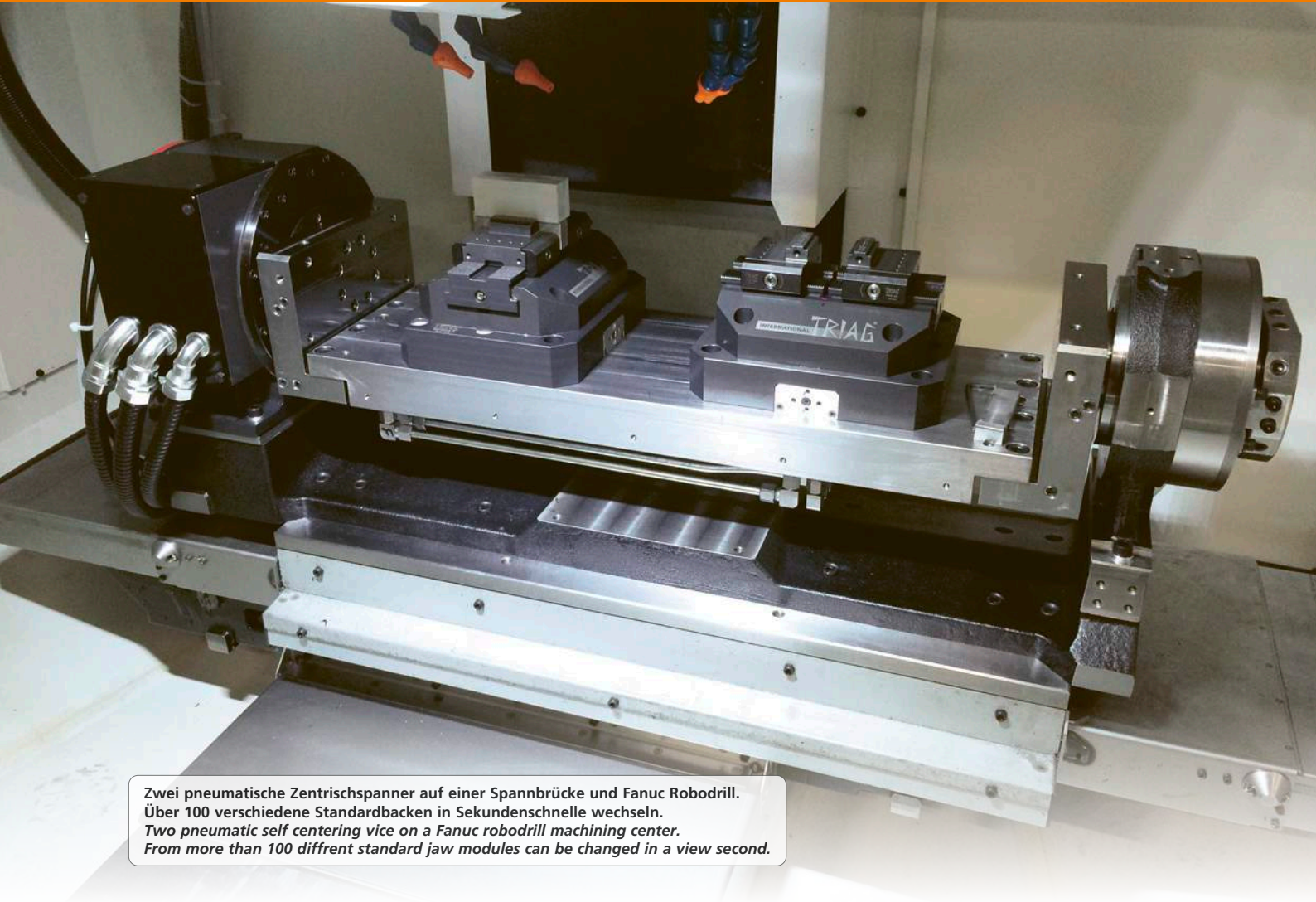

Zwei pneumatische Zentrischspanner auf einer Spannbrücke und Fanuc Robodrill.
Über 100 verschiedene Standardbacken in Sekundenschnelle wechseln.
*Two pneumatic self centering vise on a Fanuc robodrill machining center.
From more than 100 different standard jaw modules can be changed in a view second.*

ZSP40L38SET-ZO



ZSP125L85-1



ZSP200L100

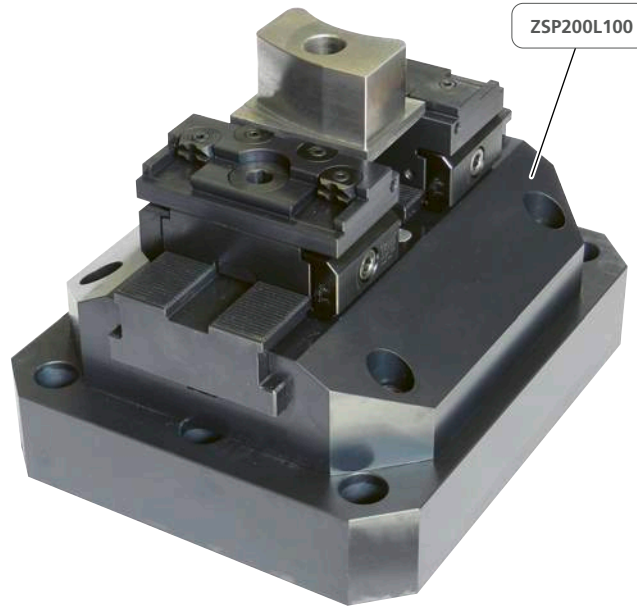

0,6 – 3,6 mm Hub

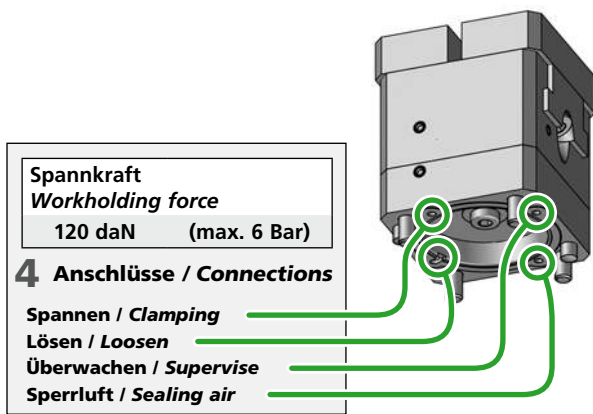
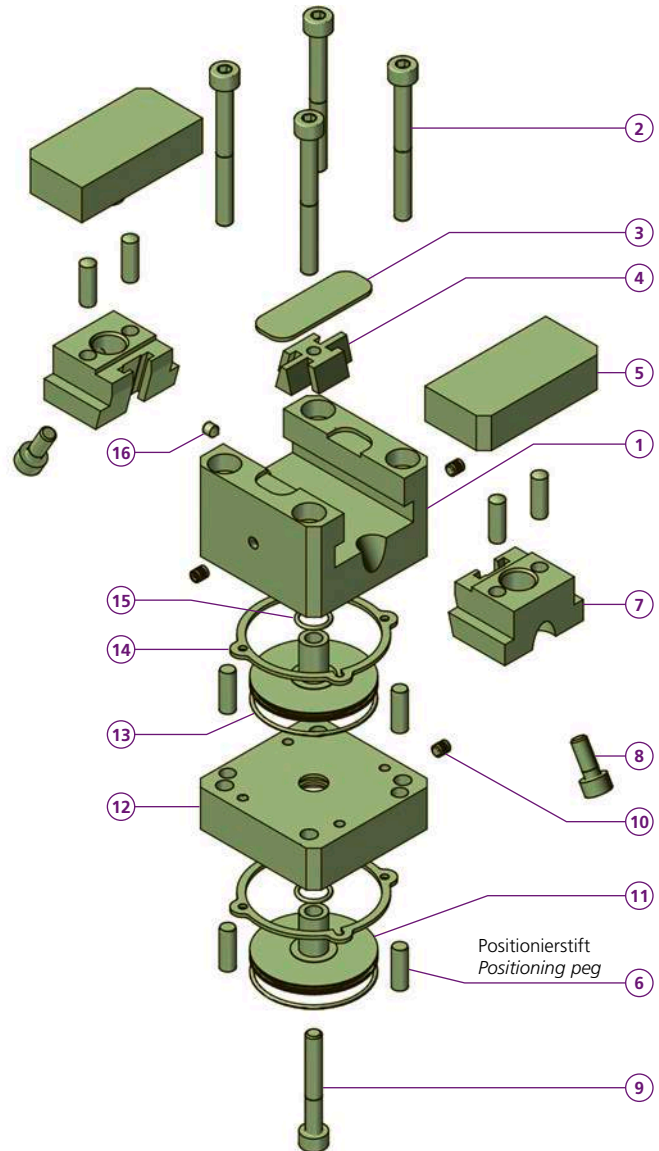
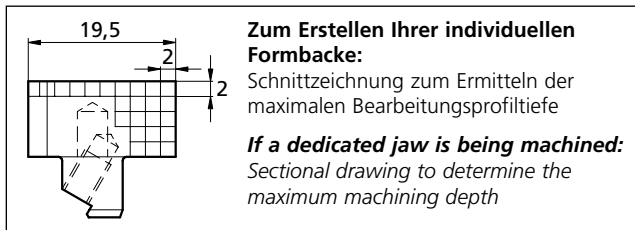
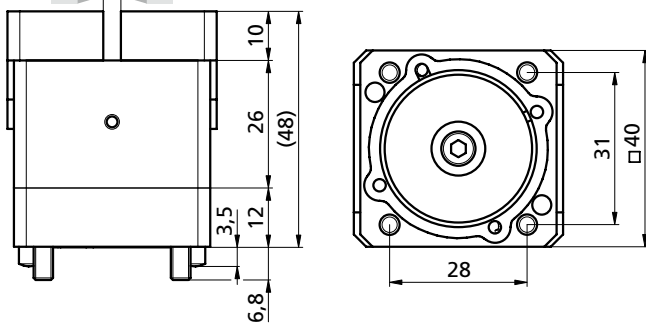

Spannkraft
Workholding force
120 daN (max. 6 Bar)

4 Anschlüsse / Connections

Spannen / Clamping
Lösen / Loosen
Überwachen / Supervise
Sperrluft / Sealing air

SET18ZSP40L38-2

- 1 1x TF180166
- 2 4x TN100865
- 3 1x TF180169
- 4 1x TF180168
- 5 2x B222
- 6 8x TN100428
- 7 2x TF180167
- 8 2x TN100321
- 9 1x TB180316
- 10 3x TN100824
- 11 2x TF180170
- 12 1x TF180171
- 13 2x TN100819
- 14 2x TB180306
- 15 2x TN100818
- 16 1x TN10091

kg ~0,52

| Luftvolumen / Air volume | |
|--------------------------|--------------------|
| Spannen / Clamping | Lösen / Loosen |
| 8,2cm ³ | 8,4cm ³ |

 **Bedienungsanleitung zu diesem pneumatischen Zentrischspanner**
Operating instructions for this pneumatic self centering vise

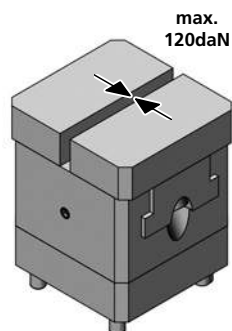

weich soft 1.7225

ZSP40L38-2

5 2x B222
kg ~5,2

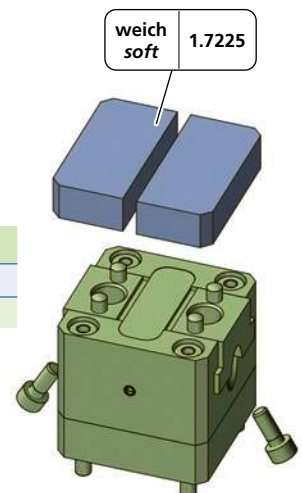

Bestellbeispiel / Ordering example: SET18ZSP40L38-2

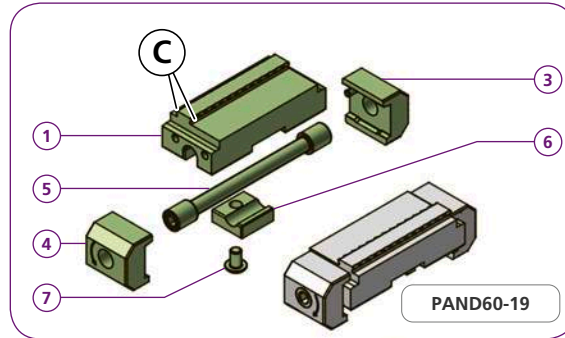
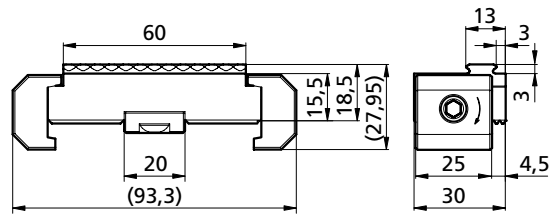
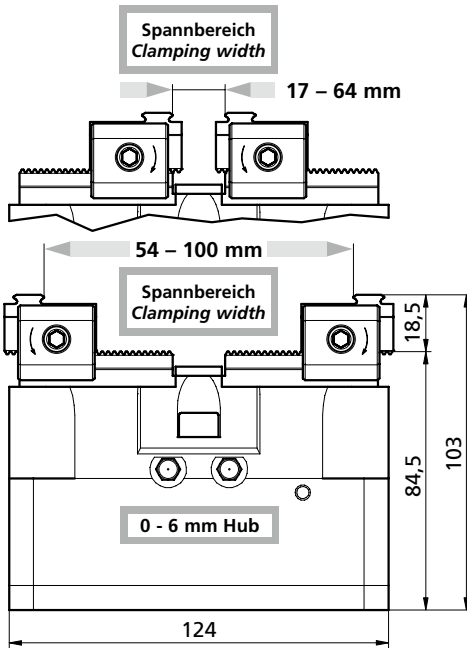

ZSP125L85-1

- 1 1x TB180474
 - 2 2x TB180476
 - 3 2x **M8X16ISO4762**
 - 4 2x M3X6DIN7991
 - 5 1x TB171140
 - 6 1x TB171141
 - 7 1x TB180477
 - 8 2x TN100014
 - 9 2x TB170530
 - 10 2x TN100021
 - 11 3x TN100009
 - 12 1x TK160467
 - 13 1x TN100012
 - 14 1x TK160075
 - 15 1x **M6X35ISO4762**
 - 16 1x TN100020
 - 17 1x TB180475
 - 18 2x TN100015
 - 19 4x TN100013
 - 20 1x TN100027
 - 21 1x TB180268
 - 22 4x PCPF16L6
 - 23 1x M5X6DIN913
 - 24 1x TB180478
- kg ~7,4

PAND60-19

- 1 1x TB171149
 - 3 1x PCSP25L
 - 4 1x PCSP25R
 - 5 1x PCS10
 - 6 1x PCGU2019
 - 7 1x **M5X8ISO7380**
- kg ~0,4

| Luftvolumen / Air volume | |
|--------------------------|----------------------|
| Spannen / Clamping | Lösen / Loosen |
| 80,1 cm ³ | 80,8 cm ³ |



Bedienungsanleitung zu diesem pneumatischen Zentrischspanner
Operating instructions for this pneumatic self centering vise

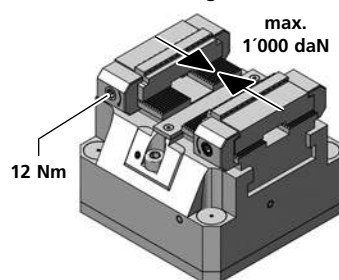

SET18ZSP125L85-1

- 1x ZSP125L85-1
 - 2x PAND60-19
- kg ~8,2

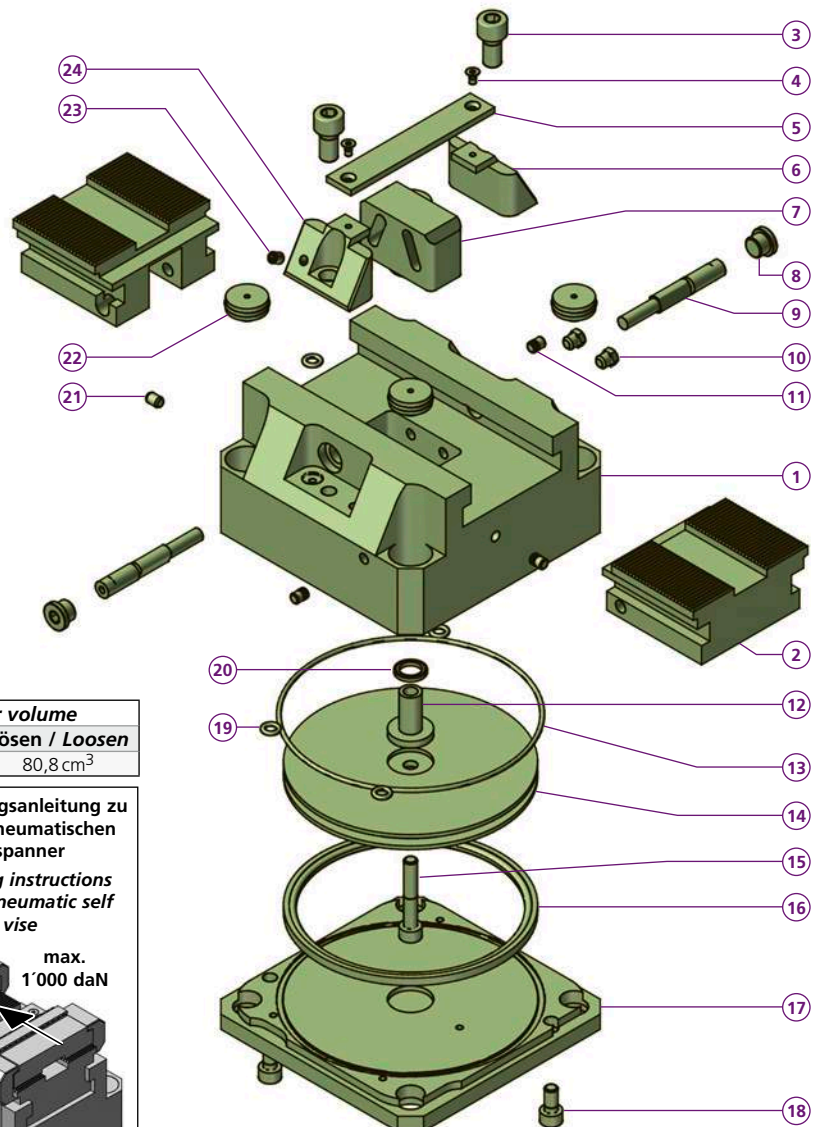

| | Druck Pressure | | Spannkraft Clamping force | | |
|-----------------------------------|-------------------|---|------------------------------|-------|-----|
| | Bar | | ~daN | ~(lb) | ~t |
| Einfacher Kolben Single piston | 8 | = | 600 | 1'320 | 0,6 |
| | 10 | = | 800 | 1'760 | 0,8 |
| | 12 | = | 1'000 | 2'650 | 1,0 |

Bestellbeispiel / Ordering example: SET18ZSP125L85-1

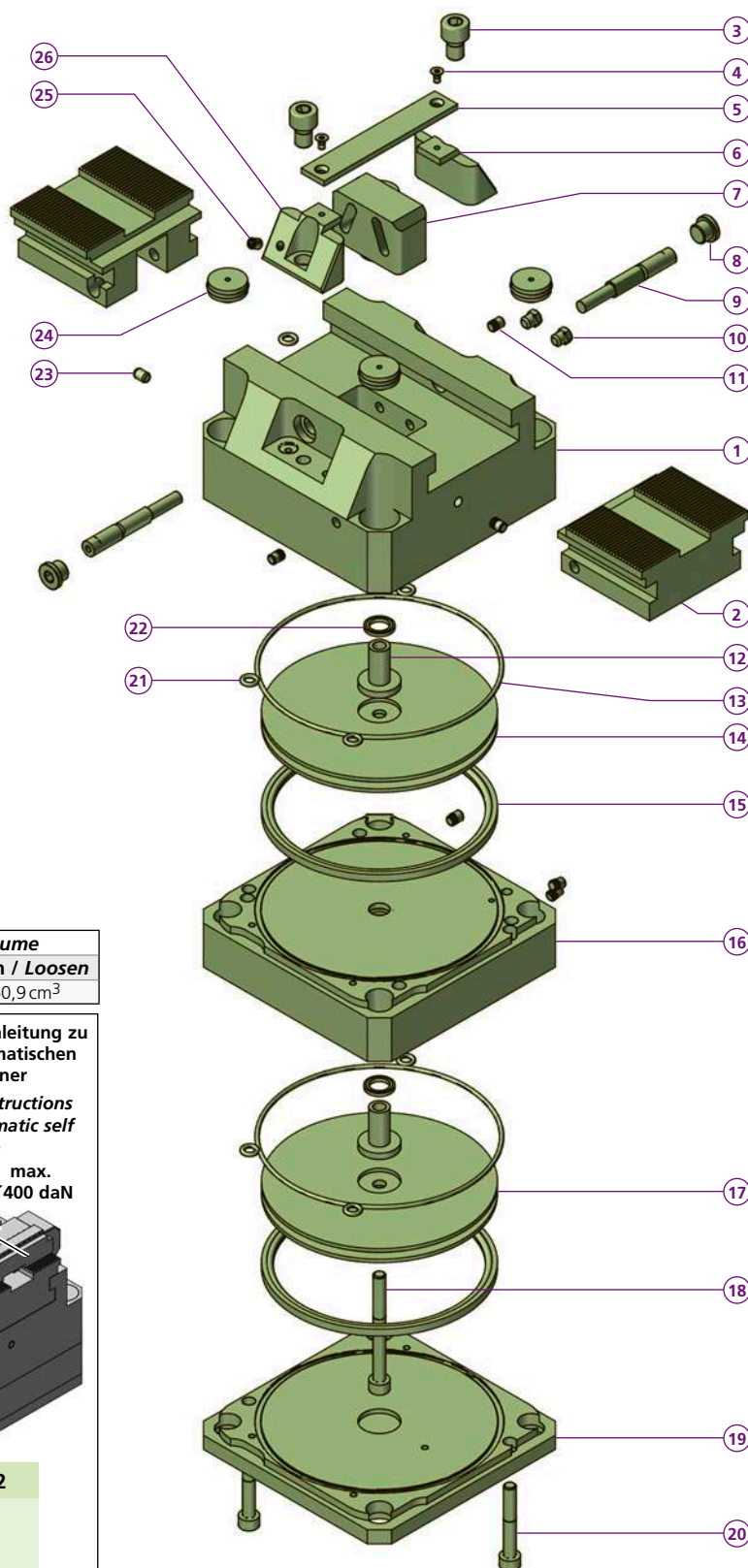
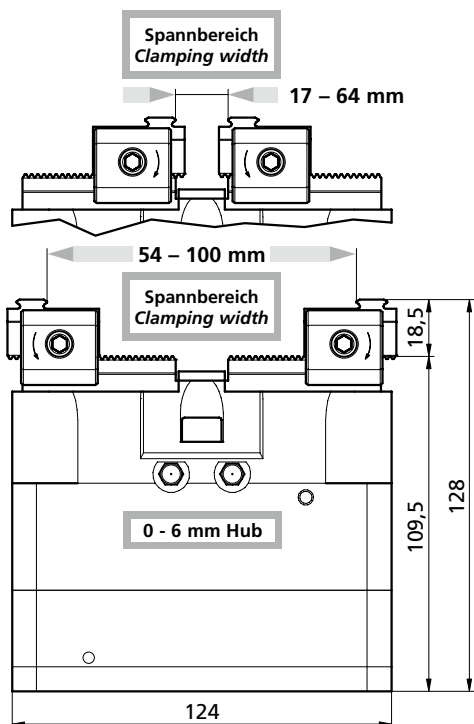

- ZSP125L110-2**
- 1 1x TB180474
 - 2 2x TB180476
 - 3 2x **M8X16ISO4762**
 - 4 2x M3X6DIN7991
 - 5 1x TB171140
 - 6 1x TB171141
 - 7 1x TB180477
 - 8 2x TN100014
 - 9 2x TB170530
 - 10 2x TN100021
 - 11 6x TN100009
 - 12 2x TK160467
 - 13 2x TN100012
 - 14 1x TB170147
 - 15 2x TN100020
 - 16 1x TB180480
 - 17 1x TK160075
 - 18 1x **M6X60ISO4762**
 - 19 1x TB180475
 - 20 2x **M6X40ISO4762**
 - 21 7x TN100013
 - 22 2x TN100027
 - 23 1x TB180268
 - 24 4x PCPF16L6
 - 25 1x M5X16DIN913
 - 26 1x TB180478
- kg ~9,4**

| Luftvolumen / Air volume | |
|--------------------------|-----------------------|
| Spannen / Clamping | Lösen / Loosen |
| 160,2 cm ³ | 160,9 cm ³ |

Bedienungsanleitung zu diesem pneumatischen Zentrischspanner
Operating instructions for this pneumatic self centering vise

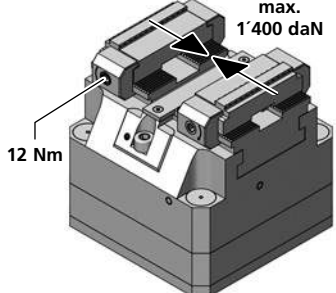
max. 1'400 daN

12 Nm

SET18ZSP125L110-2

1x ZSP125L110-2
2x PAND60-19
kg ~11,3

- PAND60-19**
- 1 1x TB171149
 - 3 1x PCSP25L
 - 4 1x PCSP25R
 - 5 1x PCS10
 - 6 1x PCGU2019
 - 7 1x **M5X8ISO7380**
- kg ~0,4**

Masszeichnung & Isometrische Darstellung:
Siehe Seite | See page **p. 159**
Dimensional drawing & Isometric representation:

| Druck Pressure | Spannkraft Clamping force | | |
|----------------------------|---------------------------|---------|-----------|
| | Bar | ~daN | ~(lb) ~t |
| Doppelkolben Double piston | 8 | = 1'000 | 2'200 1,0 |
| | 10 | = 1'400 | 3'090 1,4 |

Bestellbeispiel / Ordering example : **SET18ZSP125L110-2**

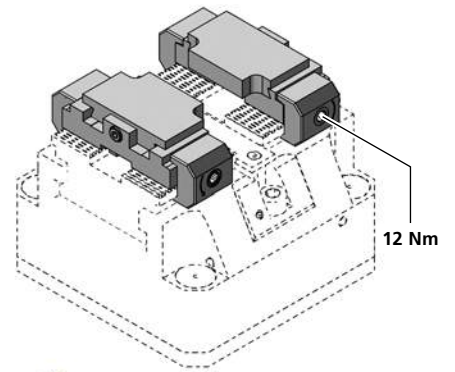
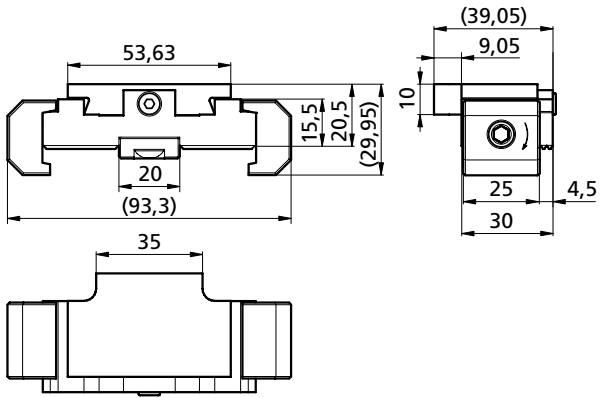

PAND60-20.5UWB

| | |
|----|----------------|
| 1 | 1x TK171294 |
| 2 | 1x TK180360 |
| 3 | 1x PCSP25L |
| 4 | 1x PCSP25R |
| 5 | 1x PCS10 |
| 6 | 1x PCGU2019 |
| 7 | 1x M5X8ISO7380 |
| 8 | 1x M4X8ISO4762 |
| kg | ~0,3 |

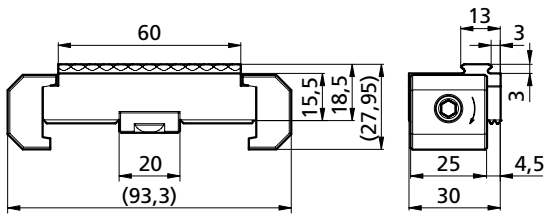
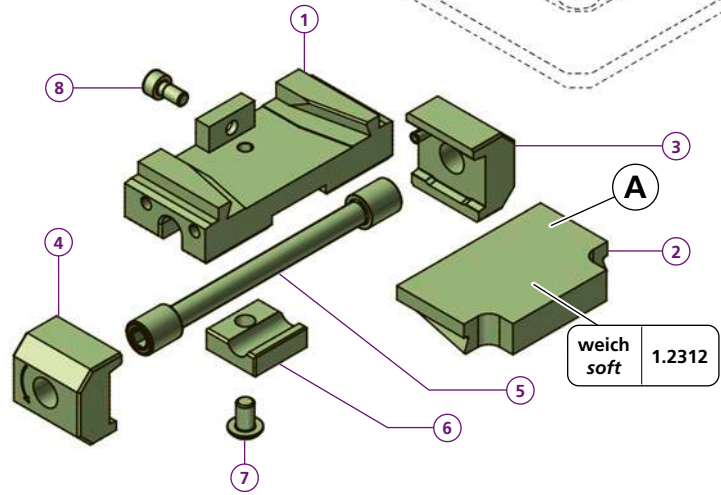

PAND60-20.5UWB

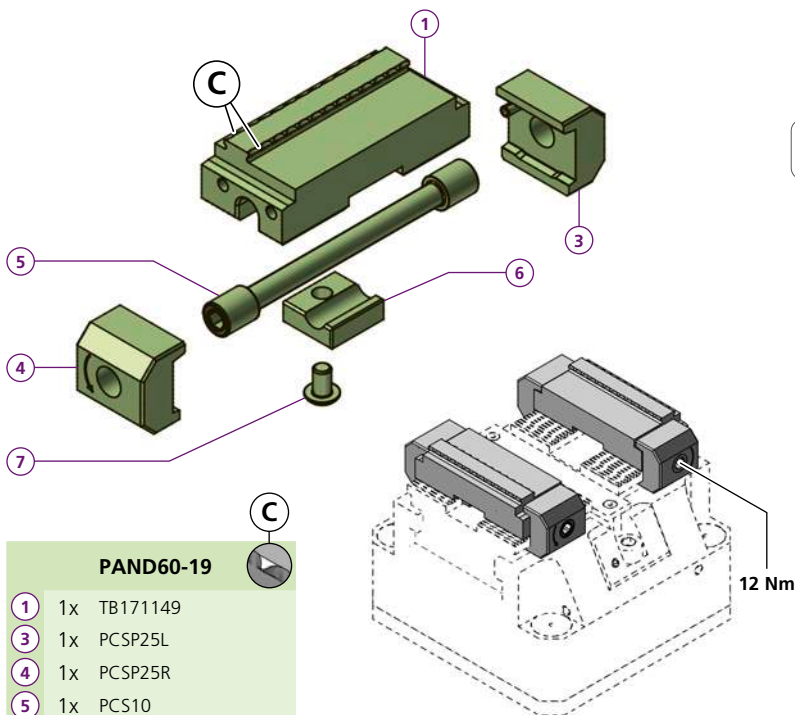

PAND60-19

| | |
|----|----------------|
| 1 | 1x TB171149 |
| 3 | 1x PCSP25L |
| 4 | 1x PCSP25R |
| 5 | 1x PCS10 |
| 6 | 1x PCGU2019 |
| 7 | 1x M5X8ISO7380 |
| kg | ~0,4 |

PAND60-19

ZSP125L85-1

Bestellbeispiel / Ordering example: PAND60-20.5UWB

ZSP Grande Pneumatischer Zentrischspanner

Pneumatic self centering vise

ZSP150L100 ZSP200L100 ZSP250L100 **triCENTRO**

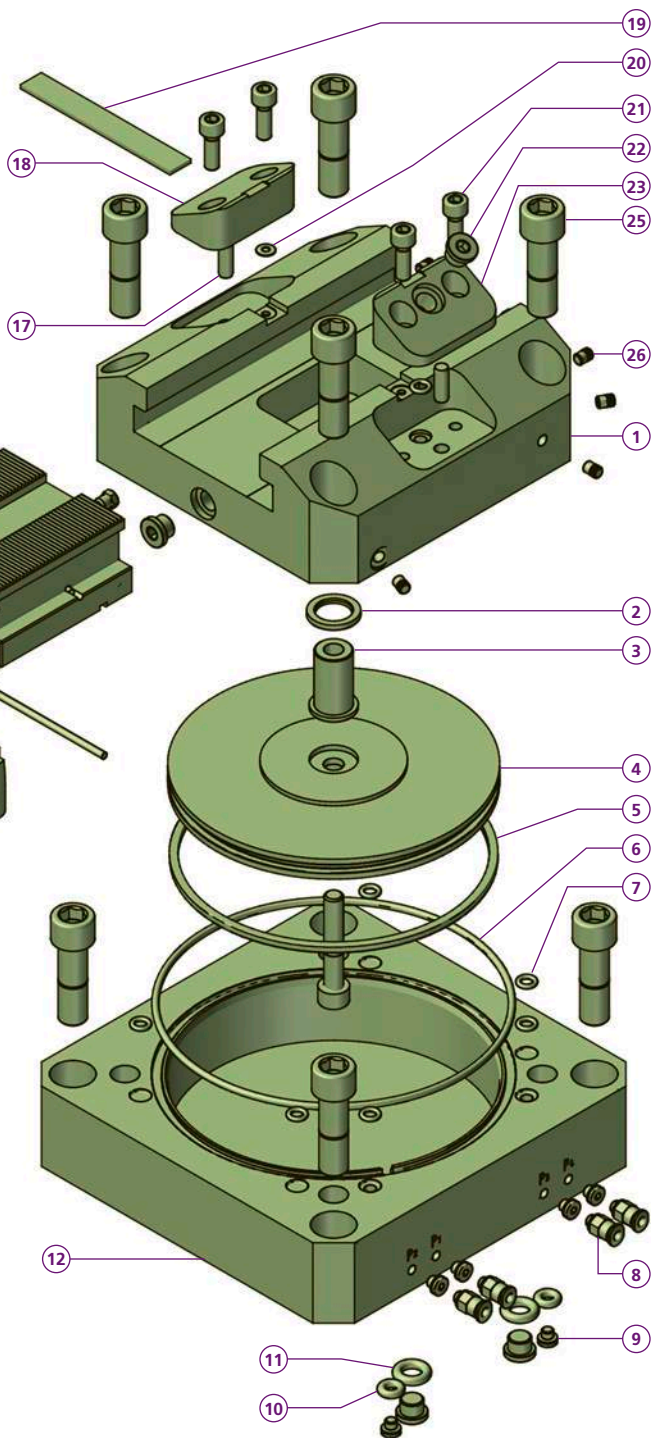
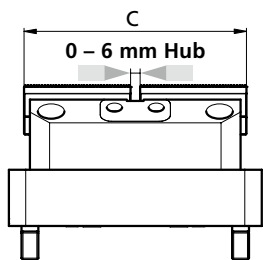
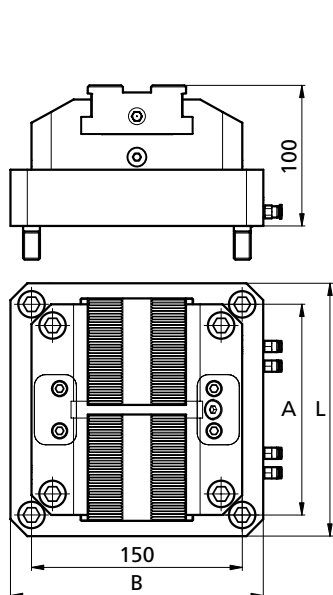

ZSP150L100

| | | |
|----|----|---------------------|
| 1 | 1x | TB190122 |
| 2 | 1x | TN100525 |
| 3 | 1x | TB140209 |
| 4 | 1x | TB190092 |
| 5 | 1x | TN100595 |
| 6 | 1x | TN100894 |
| 7 | 7x | TN100013 |
| 8 | 4x | TN100596 |
| 9 | 6x | TN100914 |
| 10 | 2x | TN100917 |
| 11 | 2x | TN100592 |
| 12 | 1x | TB190125 |
| 13 | 2x | TB190087 |
| 14 | 1x | TB190085 |
| 15 | 2x | TN100021 |
| 16 | 2x | TB190123 |
| 17 | 2x | TN100453 |
| 18 | 1x | TB190095 |
| 19 | 1x | TB190086 |
| 20 | 2x | TN100916 |
| 21 | 4x | M6X18ISO4762 |
| 22 | 5x | TN100014 |
| 23 | 1x | TB190094 |
| 24 | 8x | TWPAS1240 |
| 25 | 5x | TN100009 |
| A | = | 150 |
| L | = | 180 |
| B | = | 180 |
| kg | = | ~16 |

Bedienungsanleitung zu diesem pneumatischen Zentrischspanner
Operating instructions for this pneumatic self centering vise

Bedienungsanleitung zu diesem pneumatischen Zentrischspanner
Operating instructions for this pneumatic self centering vise

ZSP250L100

| | | |
|----|----|----------|
| 1 | 1x | TB190083 |
| 12 | 1x | TB190091 |
| 16 | 2x | TF190780 |
| A | = | 200 |
| L | = | 240 |
| B | = | 200 |
| C | = | 250 |
| kg | = | ~25,5 |

Bedienungsanleitung zu diesem pneumatischen Zentrischspanner
Operating instructions for this pneumatic self centering vise

Spannkraft siehe Seite 161
Clamping force see page 161

Bestellbeispiel / Ordering example: **ZSP150L100**

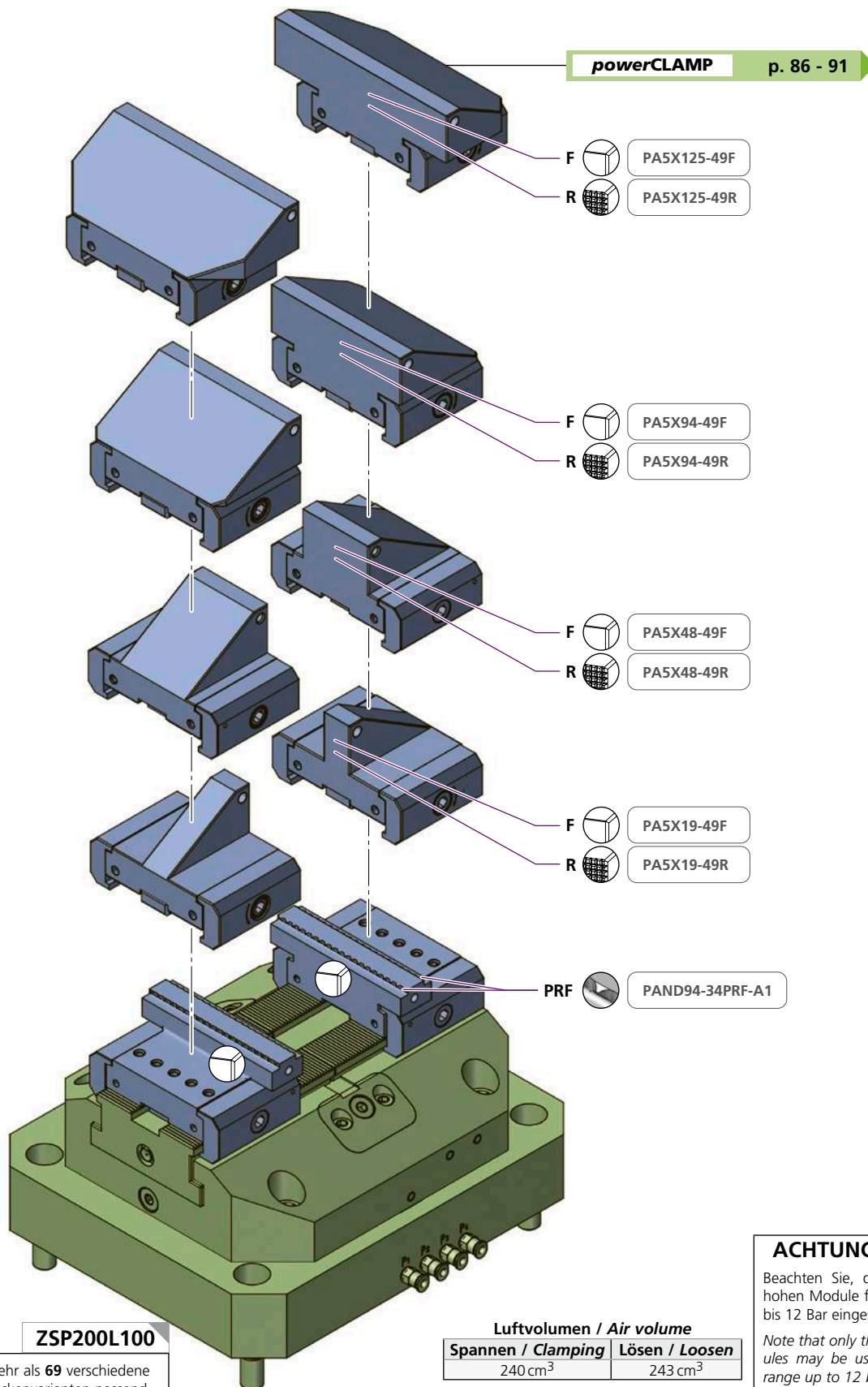

ZSP200L100

Mehr als 69 verschiedene Backenvarianten passend zu dieser Schnellwechselschnittstelle.

More than 69 different jaw modules to match this rapidly changing interface.

Luftvolumen / Air volume

| | |
|---------------------------|-----------------------|
| Spannen / Clamping | Lösen / Loosen |
| 240 cm ³ | 243 cm ³ |

| Druck / Pressure | Spannkraft / Clamping force | | | |
|--|-----------------------------|---------|-------|-----|
| | Bar | ~daN | ~(lb) | ~t |
| Druckübersetzer Pressure intensifier 1:2 | 5 | = 1'100 | 2'420 | 1,1 |
| | 8 | = 1'500 | 3'300 | 1,5 |
| | 10 | = 2'000 | 4'400 | 2,0 |
| | 12 | = 2'400 | 5'290 | 2,4 |

ACHTUNG / CAUTION

Beachten Sie, dass nur die 34 mm hohen Module für den Druckbereich bis 12 Bar eingesetzt werden dürfen.

Note that only the 34 mm high modules may be used for the pressure range up to 12 bar.

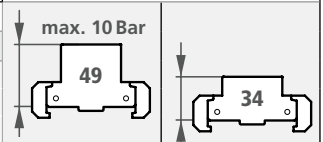

Bestellbeispiel / Ordering example: 1 x ZSP200L100 & 2 x PA5X48-49F

Separat bestellen / Order separately

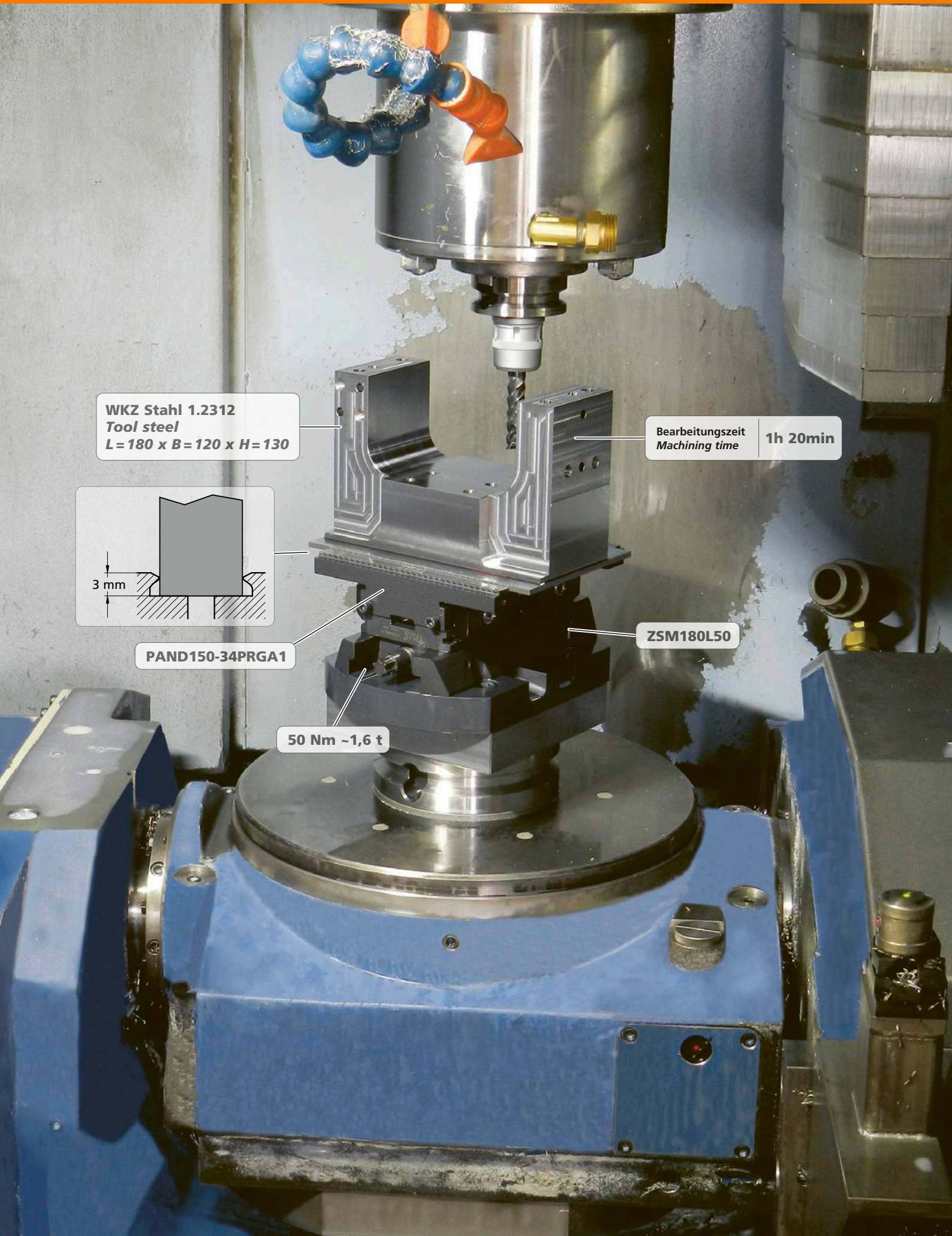

WKZ Stahl 1.2312
Tool steel
L = 180 x B = 120 x H = 130

Bearbeitungszeit
Machining time 1h 20min

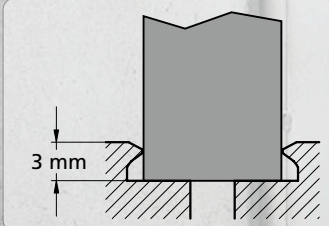

PAND150-34PRGA1

ZSM180L50

50 Nm ~1,6 t



microCLAMP



compactCLAMP

Mehrfachspannsystem / Multiple workholding system

**Nur noch Ersatzteile und
Nachlieferungen!
Keine Compact Clamp
Neuentwicklungen mehr!**

Beim Compact Clamp lassen sich die Spannmodule auf einer Basisschiene mittels Passstiften massgenau positionieren. Die Schienen sind mit einem Lochraster mit 7,5 mm Teilung, die Spannmodule mit einer 10 mm-Teilung versehen. Dank Anwendung des Nonius-Prinzips entsteht ein kleinstmöglicher Positionierschritt von 2,5 mm. Bei einem Backenhub von 4 mm ist es somit möglich, an jedem beliebigen Punkt der Schiene nullpunktbezogen zu spannen. Ab 20 mm ist die Bearbeitung von drei Seiten möglich. Da das Spannmodul mit vier Schrauben in den T-Nuten verankert wird, ist es sinngemäss auch möglich, an Stelle der Original-Spannmodule individuelle Vorrichtungen und Sonderbacken zu befestigen. Das Compact Clamp Spannsystem ist ein System für Tüftler. Praktisch keine Spannprobleme bleiben damit ungelöst. Dafür sind die Umrüstzeiten etwas länger als beim Power Clamp. Compact Clamp-Basisschienen sind in den Längen 113 - 750 mm lieferbar. Die angebotenen Befestigungsrastrer sind 40 und 50 mm. Neben den Stahlschienen werden für leichte Arbeiten auch Schienen aus Aluminium hergestellt.

**Only spare parts and
additional deliveries! No
more new Compact Clamp
developments!**

In the Compact Clamp, the vise modules are positioned precisely on a base rail by means of alignment pins. On the base rail, positioning holes are located on a 7,5 mm grid, while on the vise module there is one with a 10 mm spacing. Following the vernier principle, the smallest possible positioning step is therefore 2,5 mm. With a jaw movement of 4 mm it is therefore possible to clamp the workpiece in any desired position with a known distance to program Zero (original datum face). From 20 mm up, three sided machining is possible. Special jaws or dedicated fixtures may easily be bolted onto the rails in place of standard vise modules if the need arises. They may be anchored in the T-slots and located by using alignment pins in the positioning holes. Hence the Compact Clamp is the ideal workholding system for "do it yourself" customers. Change over times are longer than with the Power Clamp, though. Available Compact Clamp base rails lengths: 113 - 750 mm. The fastening grids on the rails are 40 and 50 mm. In addition those made of steel we also produce rails made of aluminum for light work.



Sie können den
Katalog unter der
folgenden Link herunter-
laden!

You can download the
catalogue at the fol-
lowing download
link!



Einleitung | *Introduction* 166 - 167

Anwendungsbeispiele | *Examples of application* 168 - 171



Spannkraft und Drehmoment | *Workholding force and torque* 173

Vorrichtungsbau - Präge- und Anschlagmodule (Linear)
For dedicated fixture - stamping- and end modules (linear) 174 - 176

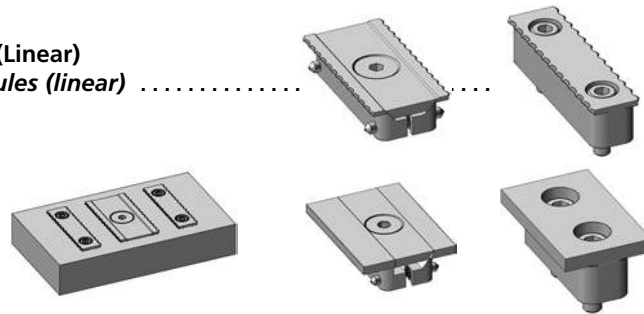

Niederzugspannmodule | *Pull down clamp modules* 177 - 195

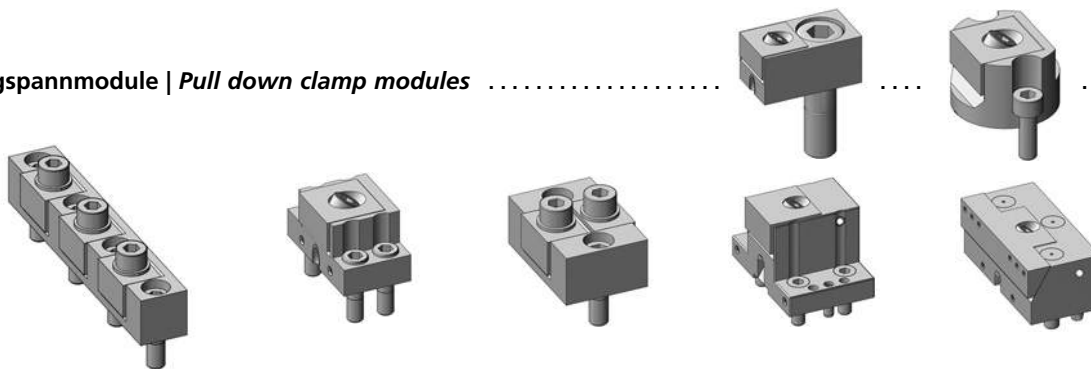

Linearspannmodule | *Linear clamping modules* 196 - 203

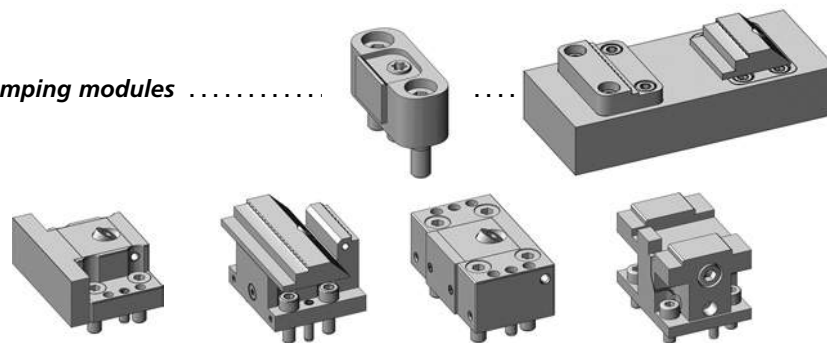

Zubehör | *Accessories* 204 - 205



Zum Aufbau kundenspezifischer Sondervorrichtungen für höchste Werkstückdichte im Arbeitsraum von Bearbeitungszentren ist das Spannsystem Micro Clamp ausgelegt (Spezielle Anschlagbacken, siehe Bild). Sehr kompakte Spannmodule mit Prägebacken verwirklichen eine zuverlässige Aufspannung bei nur etwa 2 mm Verlust an Rohmaterial

Clamps for dedicated fixtures for high density to get your best output from your machine. Clamping modules in different sizes and shapes and jaws with serrations also flat and carbide coated are available.

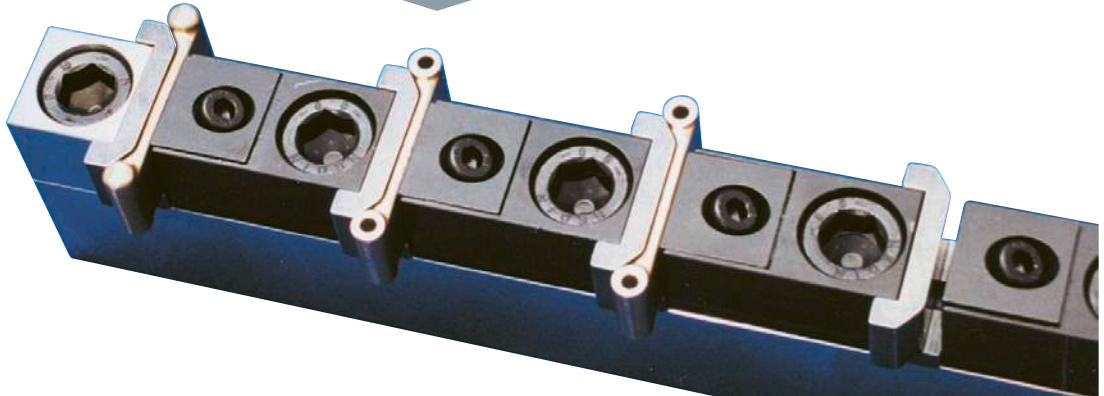

Kleinst-Spannmodule für den Vorrichtungsbau. *Extremely small clamping modules for dedicated fixtures.*

Hohe Spanndichte

Die Spannmodule haben auf der Vorderseite eine Spannbacke, die Rückseite ist zu den Befestigungsbohrungen massgenau geschliffen oder gefräst. Damit kann diese Anschlagfläche für das folgende Werkstück genutzt werden. Diese Anordnung lässt eine sehr hohe Spanndichte zu. Beim kleinsten Micro Clamp-Modul sind nur 15 mm Spannabstand erforderlich.

High workholding density

These clamping modules have a clamping jaw on the front, while rear is precisely ground or milled with reference to the fixing holes. This means that it can be used as a datum face for the following workpiece. This arrangement allows very high clamping densities. Only 15 mm clamping clearance is needed between workpieces using the smallest Micro Clamp module.

- Maximale Spannkraft der Module 2,8t (28'000N)
- Benötigter Platz zwischen den Werkstücken ab 15 mm
- Spannhub ab 1,5 mm
- Genaue Positionierung durch Passschrauben und Positionierstifte
- *Clamping force up to 2,8t (28'000N)*
- *Space between workpieces only 15 mm*
- *Stroke of jaw from 1,5 mm*
- *Precise positioning by ground shoulder screws or dowel pins*

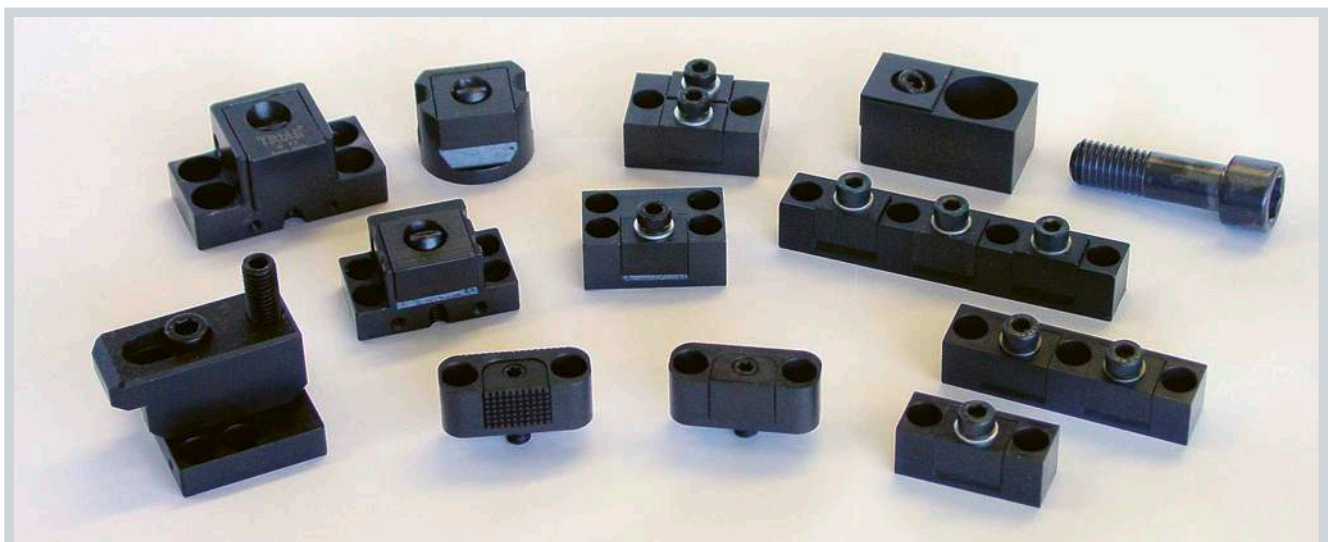

Ein grosses Angebot an verschiedensten Spannmodulen.
A wide range of clamp modules in different sizes are available

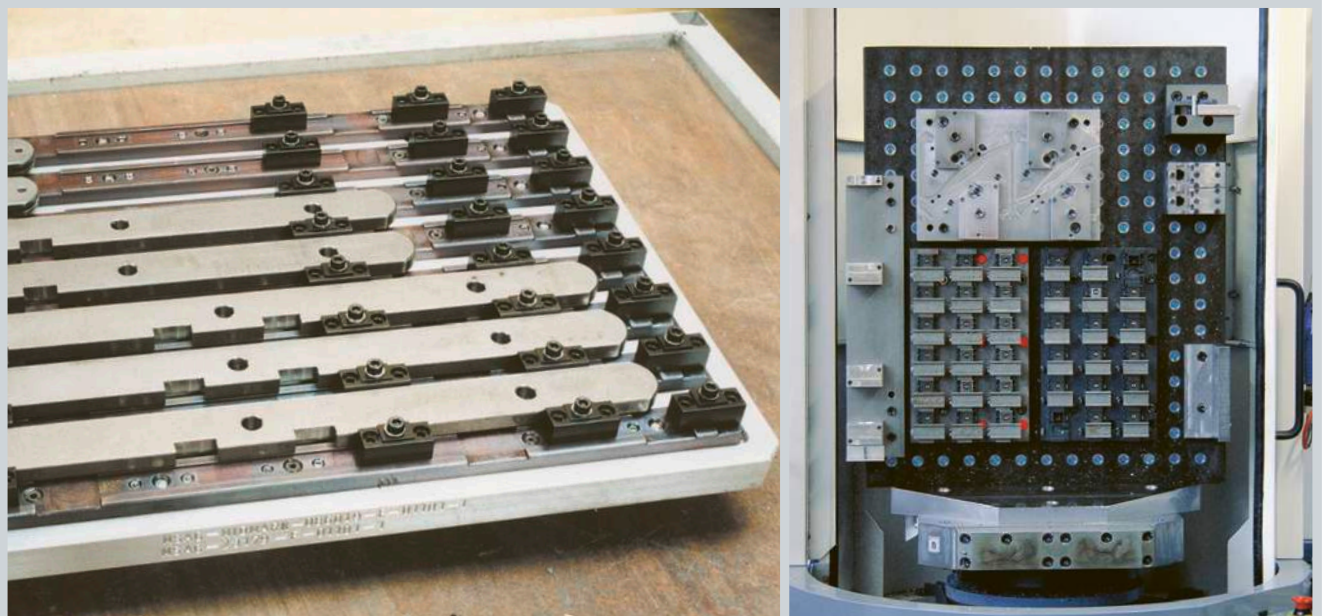

Hohe Spanndichte für Werkstücke in grossen Stückzahlen.
High density fixture plates for repeating orders in high quantities

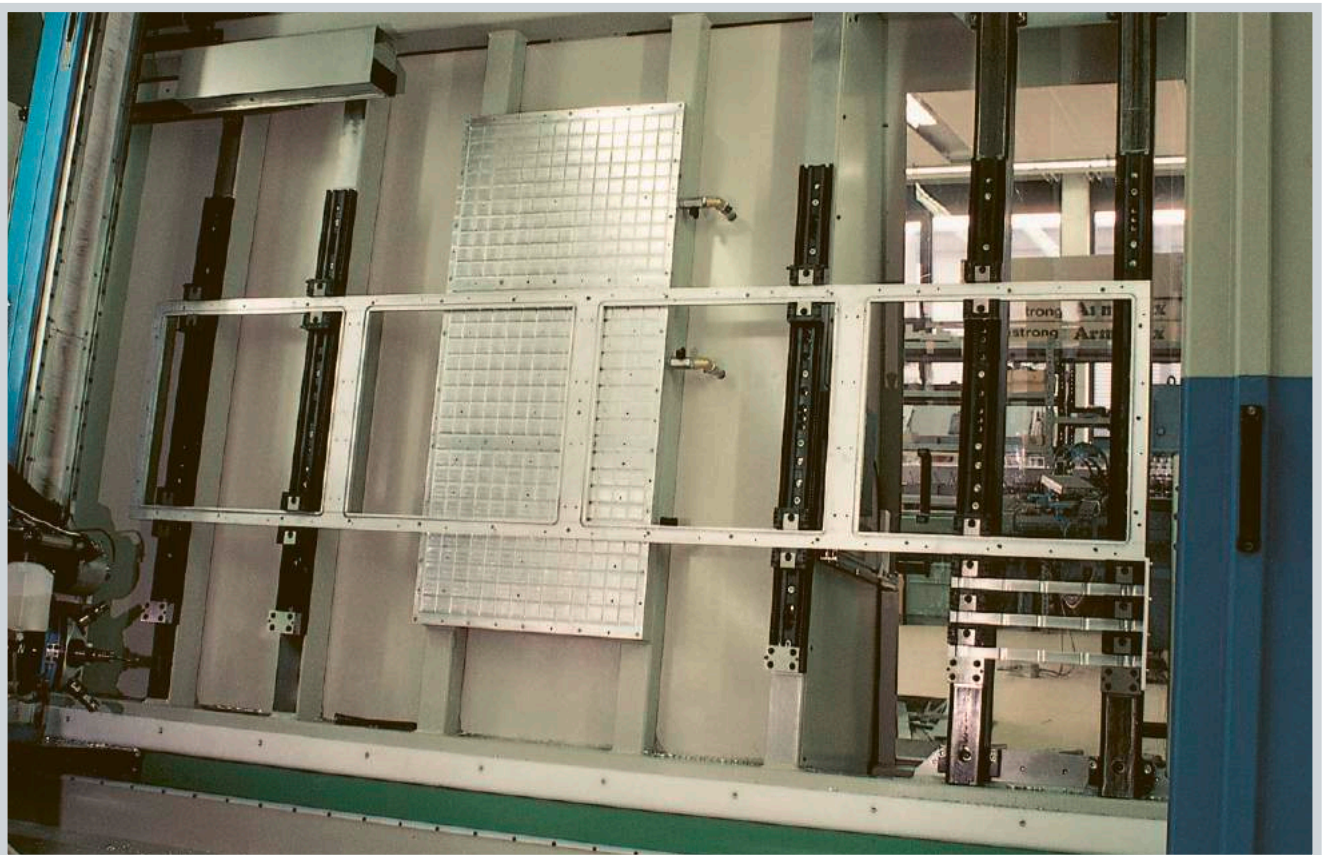

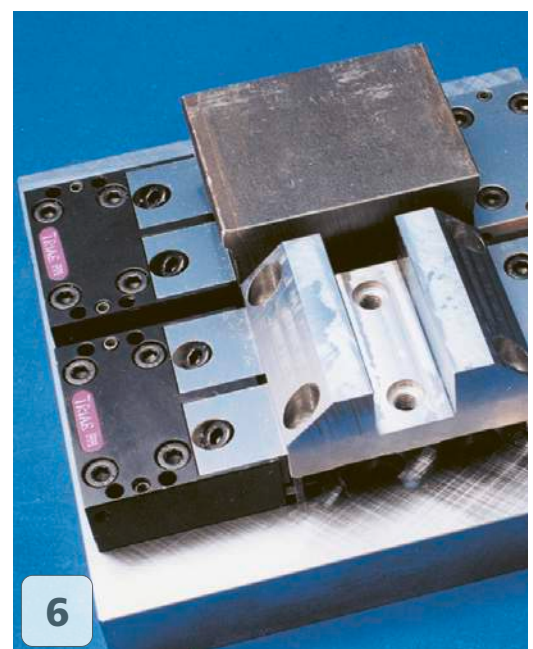
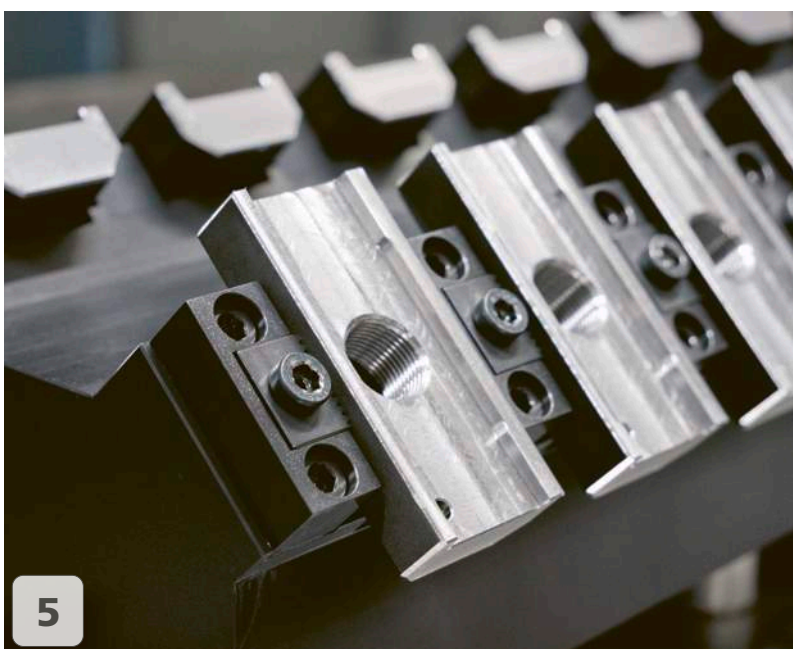
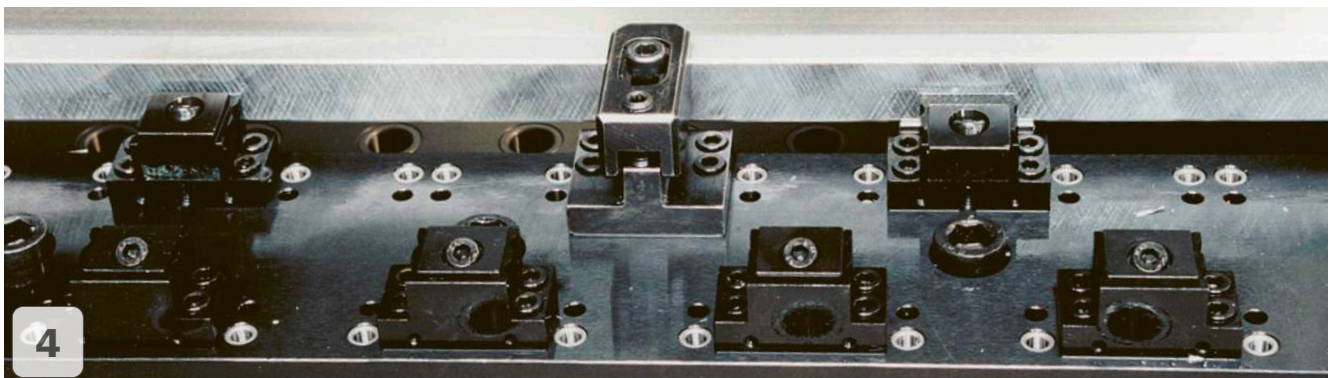
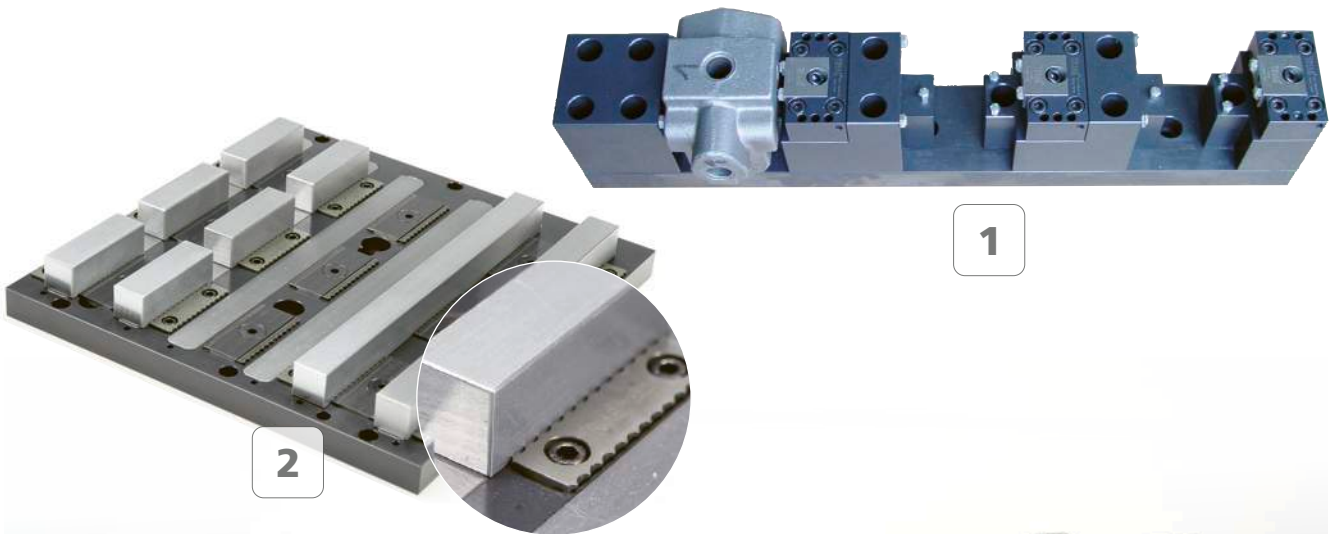



7 72 Teile sind hochgenau gespannt unter 10 my. Die Vorrichtungen sind auf einem EROWA ITS O-Punkt Spannsystem aufgebaut
72 parts are clamped within 10 microns the clamp fixtures are set up on a EROWA ITS palleting system

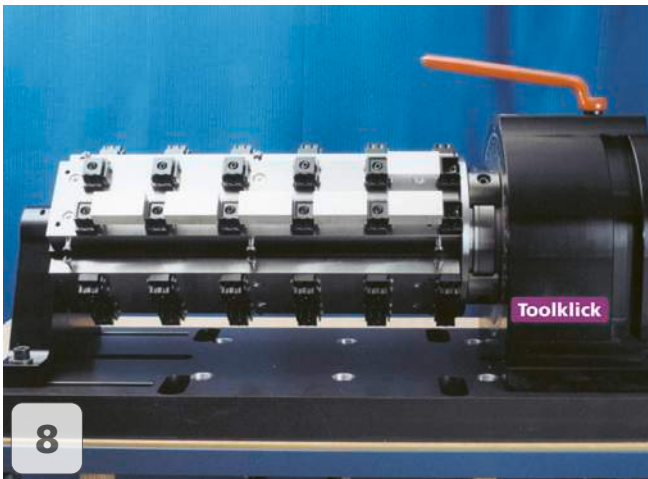

8

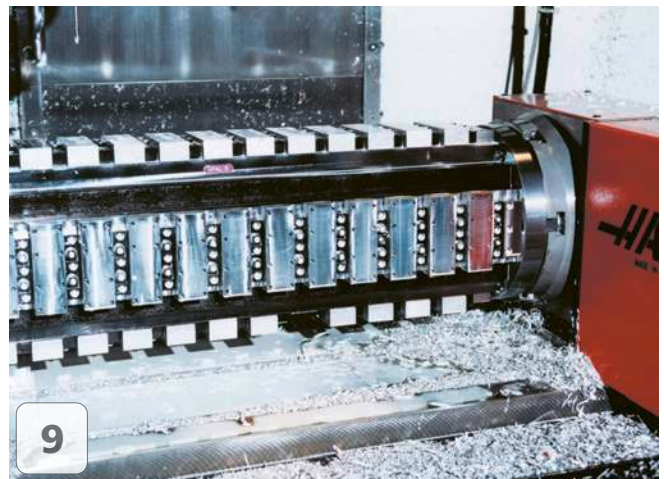

9

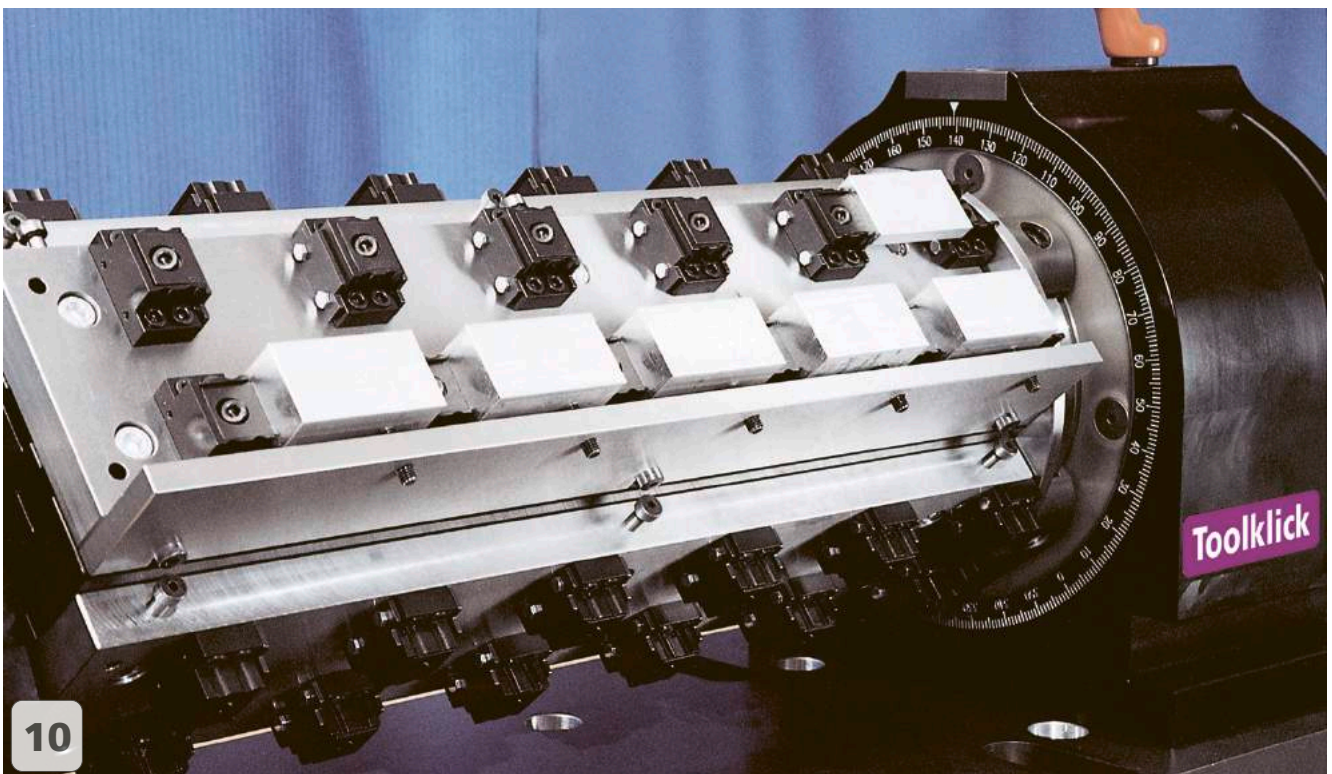

10



11 84 Teile sind gespannt mit Micro Clamp und werden jeweils nachts unbemannt produziert
84 parts are clamped with Micro Clamp and are machined always at right unmanned

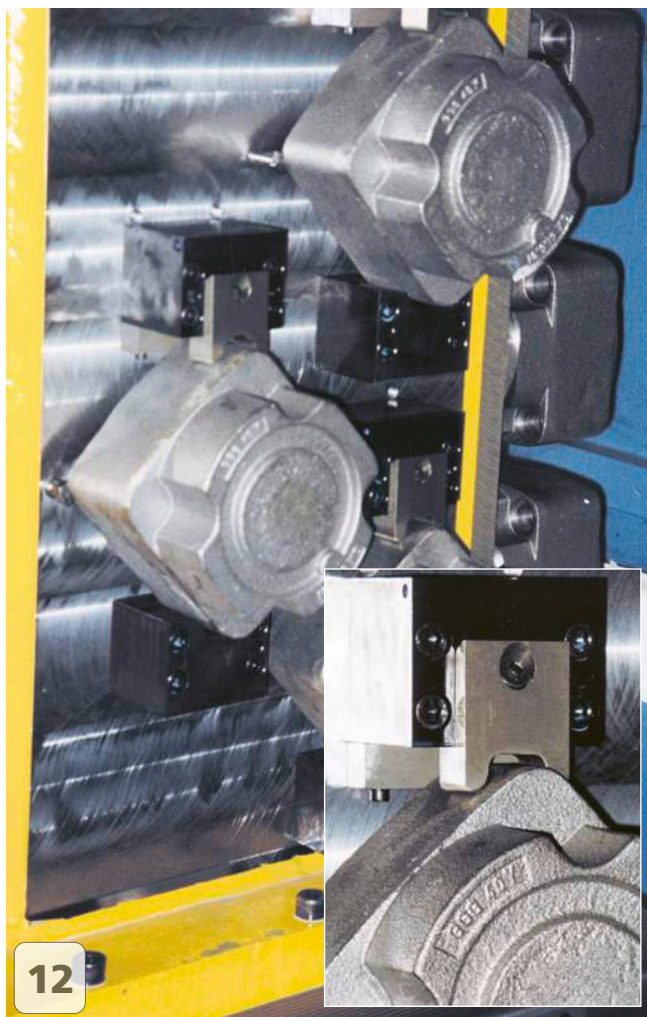

12

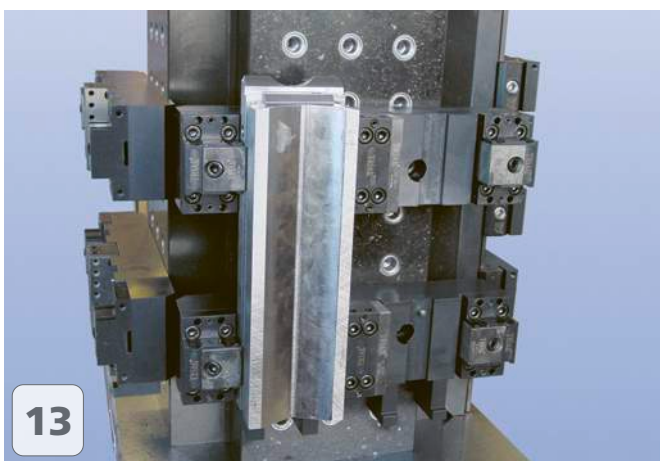

13

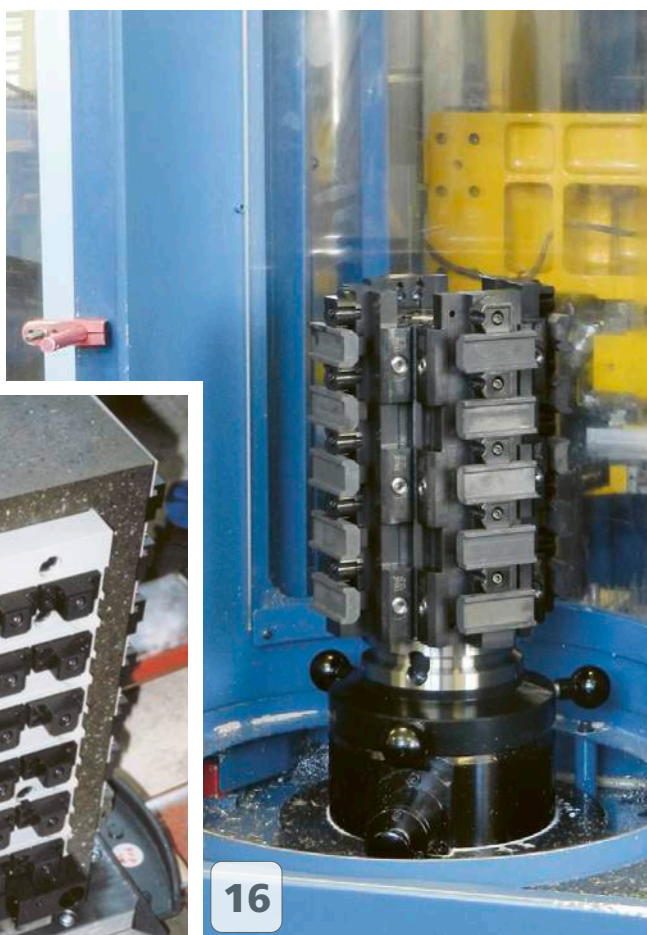

16

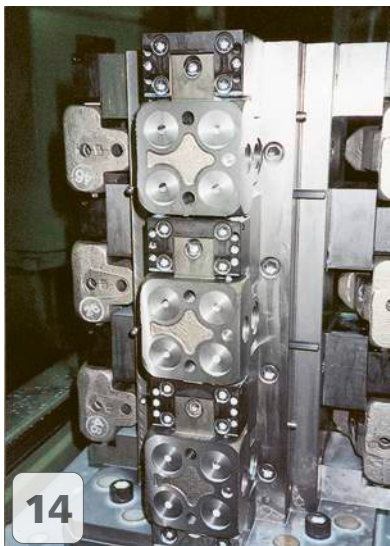

14



15

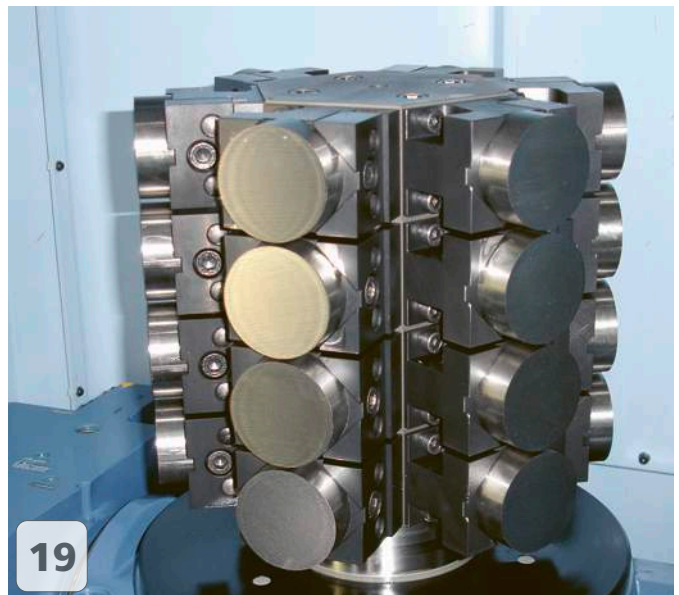
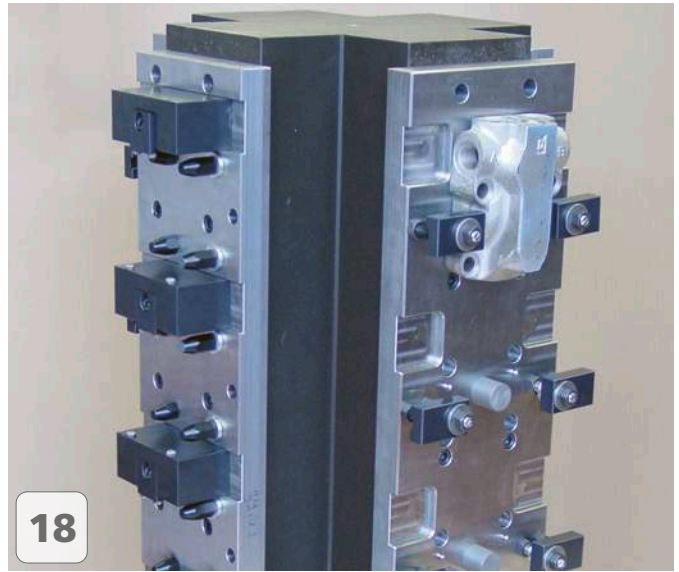
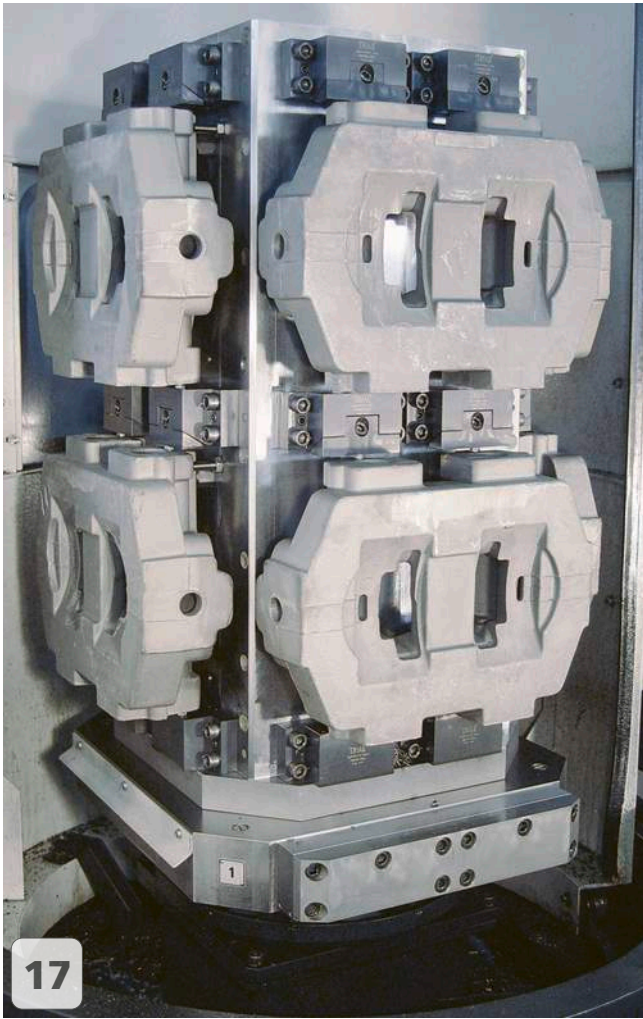

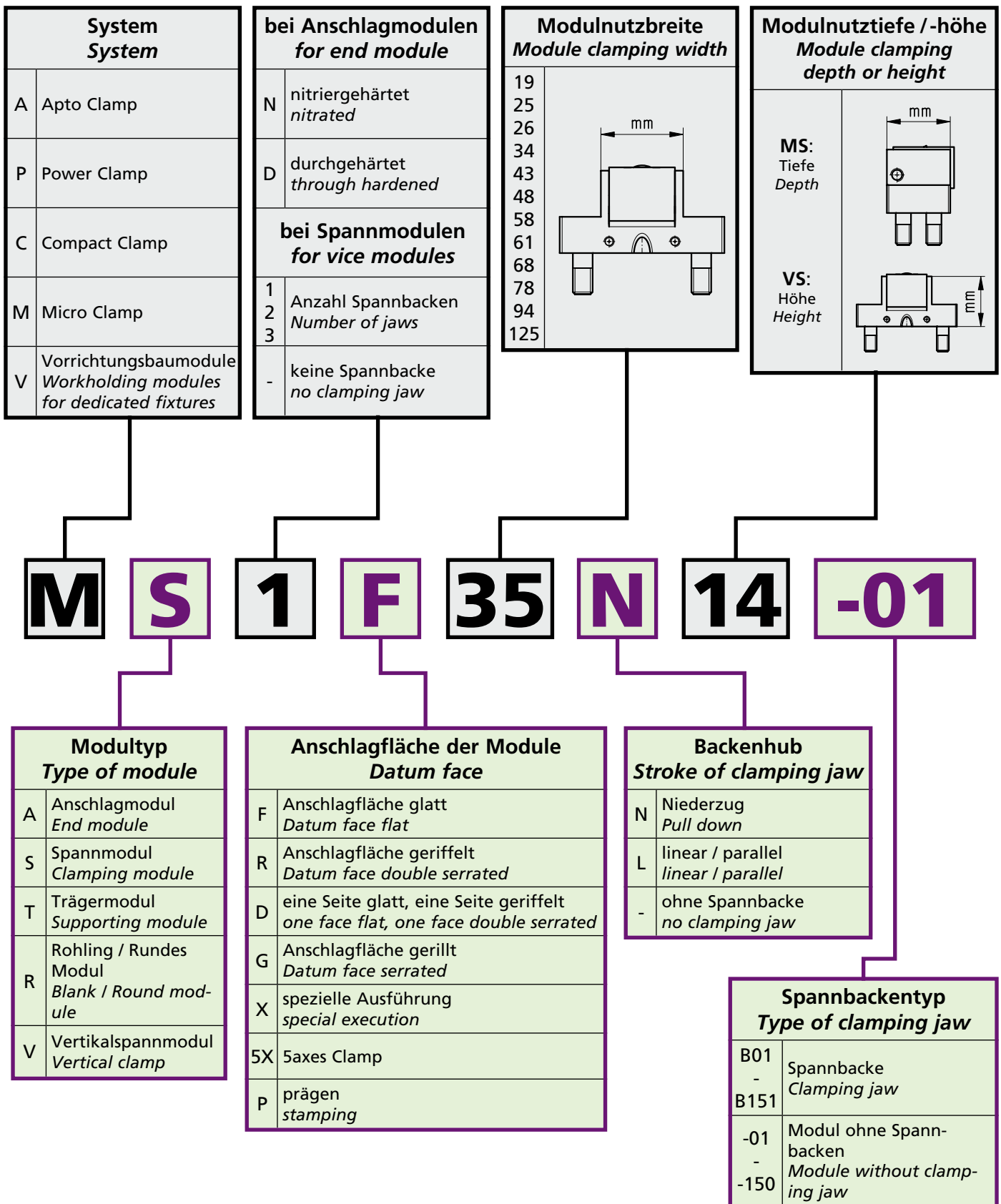

ACHTUNG / CAUTION

WICHTIG: Die im Micro Clamp Kapitel angegebenen Drehmomente sind die absoluten Maximalwerte. Über die Spannkraften gibt die untenstehende Tabelle Auskunft.

IMPORTANT: The torque numbers specified in the Micro Clamp chapter represent the absolute maximum. The table at the bottom of this page provides further information on the workholding forces.

| Linear Spannmodule Linear module | MC-Module | Schraube Screw | Drehmoment Torque | | Spannkraft Workholding force | | |
|-------------------------------------|-------------------------|-------------------|----------------------|---------|---------------------------------|--------|------|
| | | | Nm | (lb-ft) | ~daN | ~(lb) | ~t |
| | MR1F 30N23 -07 | M5 | 10 | 7,4 | = 1020 | 2250 | 1,02 |
| | MS1F 22N40 -07 | | 10 | 7,4 | = 1020 | 2250 | 1,02 |
| | MS1F 24N22 -07 | | 10 | 7,4 | = 1020 | 2250 | 1,02 |
| | MS1R/F 25N25 -13 | M6 | 15 | 11 | = 1520 | 3350 | 1,52 |
| | MS1F 35N14 -01 | M5 | 10 | 7,4 | = 1020 | 2250 | 1,02 |
| | MS1F 35N22 -01 | | 10 | 7,4 | = 1020 | 2250 | 1,02 |
| | MS2X 25N23 -01 | | 10 | 7,4 | = 1020 | 2250 | 1,02 |
| | MS2F 60N14 -01 | | 10 | 7,4 | = 1020 | 2250 | 1,02 |
| | MS3F 85N14 -01 | | 10 | 7,4 | = 1020 | 2250 | 1,02 |
| | VS1R 19N35 -20 | | M6 | 15 | 11 | = 1520 | 3350 |
| | VS1R 26N35 -26 | M8 | 25 | 18,4 | = 2100 | 4630 | 2,10 |
| | VS1R 38N50 -60 | | 25 | 18,4 | = 2100 | 4630 | 2,10 |
| | VS1R/F 41N30 -60 | | 25 | 18,4 | = 2100 | 4630 | 2,10 |
| | VS1R/F 80N30 -36 | | 25 | 18,4 | = 2100 | 4630 | 2,10 |
| | VS1R 80N50 -36 | | 25 | 18,4 | = 2100 | 4630 | 2,10 |
| VS1R/F 80N30 -60 | 25 | | 18,4 | = 2100 | 4630 | 2,10 | |
| VS1R 80N50 -60 | M10 | 25 | 18,4 | = 2100 | 4630 | 2,10 | |
| VS1R/F 125N49 -95 | | 40 | 29,5 | = 2800 | 6170 | 2,80 | |
| VS2R 80N30 -60 | | 25 | 18,4 | = 2100 | 4630 | 2,10 | |
| VS2F 90N30 -60 | | 25 | 18,4 | = 2100 | 4630 | 2,10 | |
| | MS1F (MS1R) 35L14 -152 | M6x0,5 | 10 | 7,4 | = 570 | 1260 | 0,57 |
| | MS2P (MS2P) 58L14 PRG15 | M8 | 15 | 11 | = 600 | 1320 | 0,6 |
| | MS2F (MS1F) 58L14 W251 | | 15 | 11 | = 600 | 1320 | 0,6 |
| | VS1R 26L35 -31 | | 25 | 18,4 | = 2100 | 4630 | 2,10 |
| | VS1R/F 41L30 -51 | | 25 | 18,4 | = 2100 | 4630 | 2,10 |
| | VS1R/F 80L30 -51 | | 25 | 18,4 | = 2100 | 4630 | 2,10 |
| | VS1X 68L20 -105 | | 40 | 29,6 | = 1600 | 3530 | 1,60 |
| | VS1X 59L60 K | M10 | 50 | 37 | = 1880 | 4140 | 1,88 |
| | VS1X 59L60 H5 | | 50 | 37 | = 1640 | 3620 | 1,64 |



| Schraube Screw | Drehmoment Torque | | Spannkraft Workholding force | | |
|-------------------|----------------------|--------|---------------------------------|------|------|
| M5 + M6 | 4 | 3 | = 500 | 1100 | 0,50 |
| | 5 | 3,7 | = 580 | 1280 | 0,58 |
| | 6 | 4,4 | = 690 | 1520 | 0,69 |
| | 7 | 5,2 | = 780 | 1720 | 0,78 |
| | 8 | 5,9 | = 880 | 1940 | 0,88 |
| | 9 | 6,6 | = 980 | 2160 | 0,98 |
| M6 | 10 | 7,4 | = 1020 | 2250 | 1,02 |
| | 12 | 8,9 | = 1220 | 2690 | 1,22 |
| | 14 | 10,4 | = 1450 | 3200 | 1,45 |
| M8 | 15 | 11 | = 1520 | 3350 | 1,52 |
| | 4 | 3 | = 410 | 900 | 0,41 |
| | 5 | 3,7 | = 490 | 1080 | 0,49 |
| | 6 | 4,4 | = 560 | 1250 | 0,56 |
| | 7 | 5,2 | = 660 | 1460 | 0,66 |
| | 8 | 5,9 | = 730 | 1610 | 0,73 |
| | 9 | 6,6 | = 810 | 1790 | 0,81 |
| | 10 | 7,4 | = 900 | 1980 | 0,90 |
| M10 | 15 | 11 | = 1520 | 3350 | 1,52 |
| | 20 | 14,8 | = 1810 | 3990 | 1,81 |
| | 25 | 18,4 | = 2100 | 4630 | 2,10 |
| | 10 | 7,4 | = 400 | 880 | 0,40 |
| | 20 | 14,8 | = 1400 | 3090 | 1,40 |
| | 30 | 22,1 | = 2000 | 4410 | 2,00 |
| 40 | 29,5 | = 2800 | 6170 | 2,80 | |

Vorrichtungsbau – Prägemodule

For dedicated fixture – stamping modules

Keilspanner in weicher Ausführung zum Bearbeiten von Formbacken.

Double angle clamps with soft jaws for making shaped forms.

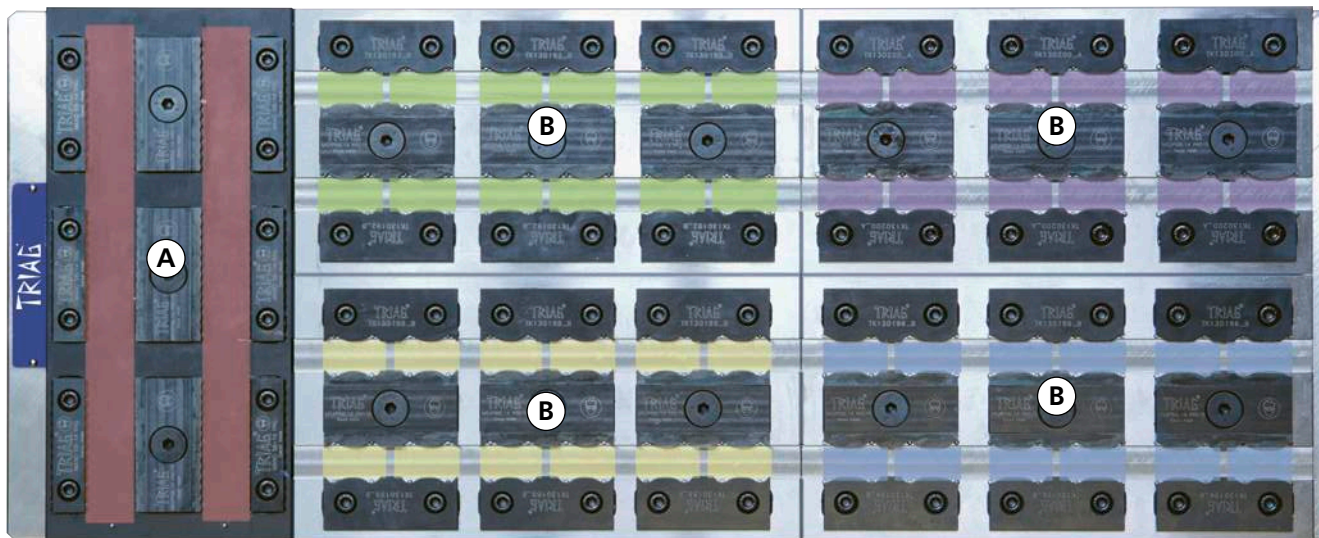

A Prägbacken Spanntiefe 1,8mm
12 Werkstücke werden hergestellt
*First clamp 12 parts with stamping jaws
clamping depth 1,8mm*

B 4 x 12 verschiedene Teile werden in der
2. Spannung bearbeitet
*4 times 12 different parts are machined
in the second operation*

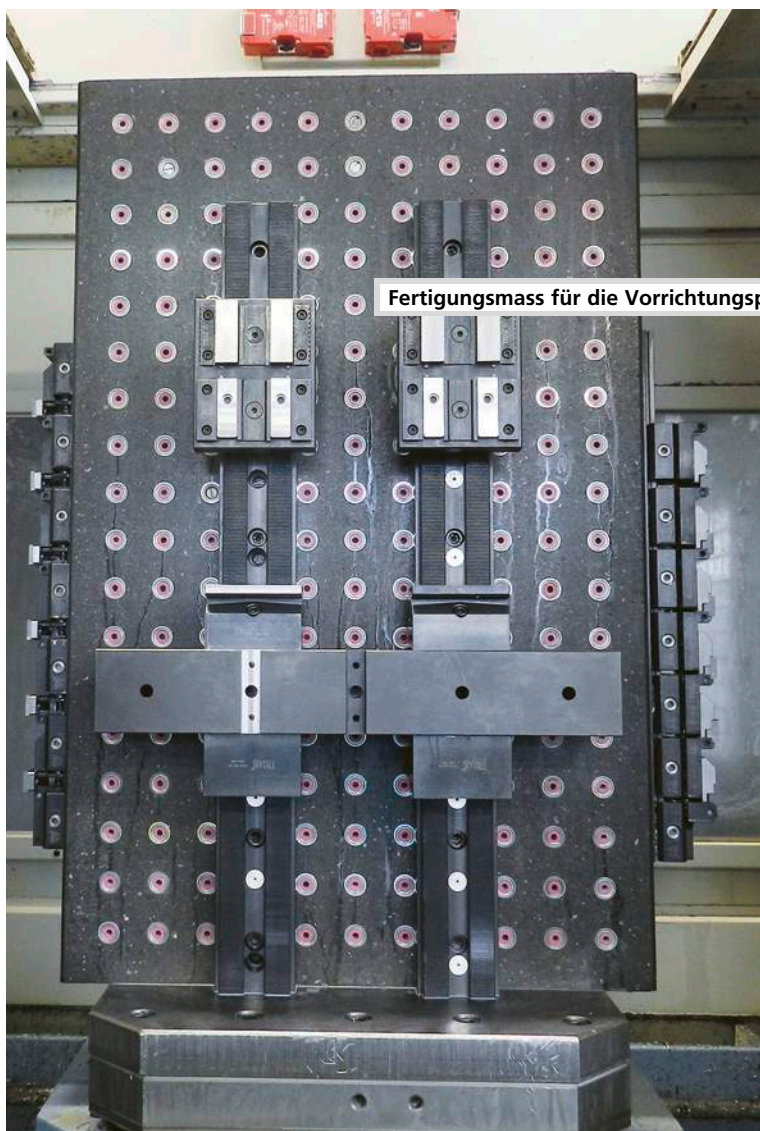

Fertigungsmass für die Vorrichtungplatte: / Machining data for the fixture plate: p. 175

Fräser / Milling cutter

Der abgebildete Fräser benötigt man für die Herstellung der «Kerben».
Siehe Fertigungsmasse für die Vorrichtungplatte Seite 175.

*The illustrated milling cutter is required for the production of "notches".
Manufacturing drawing for the fixture plate on page 175.*

| 45° | d | D | L1 | H | z | L |
|----------|---|-----|------|-----|---|----|
| TK150057 | 6 | 6,0 | 24,0 | 1,5 | 3 | 58 |

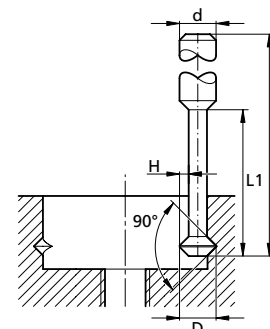

Fertigungsmasse für die Vorrichtungplatte / Machining data for the fixture plate

| | |
|--|--|
| | |
| <p>Mass X (X1) = B + 24 mm Beispiel: Bauteilbreite = 14 mm</p> <p>Dimension X (X1) = B + 24 mm Example: Width of component part = 14 mm</p> <p>Taschenabstand X = 14 + 24 = 38 Das ergibt eine Einlegeluft von 0,8 mm (Hub bis 2,7 mm)</p> | <p>Mass X2 = B + 33,5 mm Beispiel: Bauteilbreite = 14 mm</p> <p>Dimension X2 = B + 33,5 mm Example: Width of component part = 14 mm</p> <p>Taschenabstand X = 14 + 33,5 = 47,5 Das ergibt eine Einlegeluft von 0,8 mm (stroke till 2,7 mm)</p> |

Hub bis / Stroke till = 2,7 mm

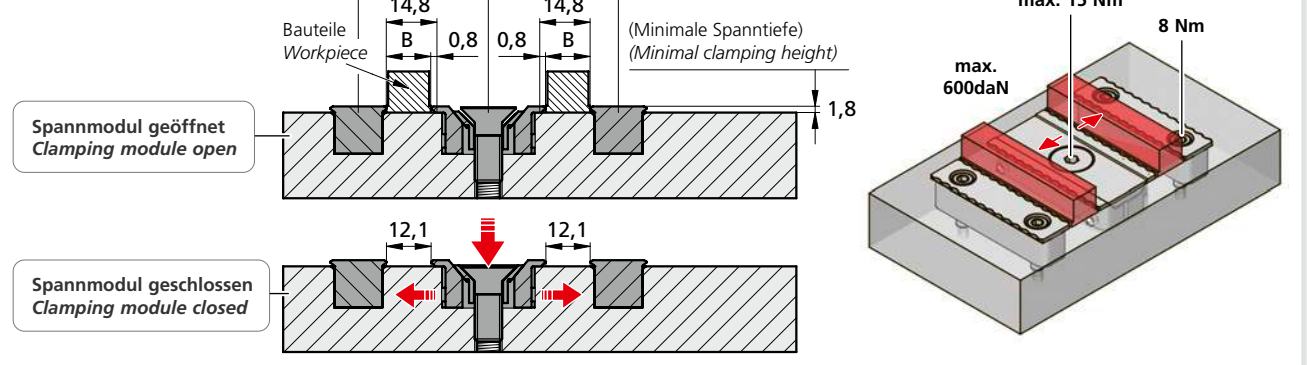

| | | | |
|--|--|--|---|
| <p>MS2P58L14PRG15</p> <p>1 2x TK120225 2 1x TK120227 3 1x M8X22DIN7991</p> <p>Y 4,7 mm i 57HRC kg ~0,12</p> | <p>MS1P58L14PRG15</p> <p>1 1x TK120225 2 1x TK120721 3 1x M8X22DIN7991 4 1x TK120720</p> <p>Y 4,7 mm i 57HRC kg ~0,12</p> | <p>MAND58-14PRG</p> <p>1 1x TK120226 3 2x M5X16ISO4762</p> <p>Y 4,7 mm i 57HRC kg ~0,08</p> | <p>MAND58-14PRG6</p> <p>1 1x TB150282 3 2x M5X16ISO4762</p> <p>Y 6,0 mm i 57HRC kg ~0,08</p> |
|--|--|--|---|

Zum Erstellen Ihrer individuellen Formbacke:
Schnittzeichnung zum Ermitteln der maximalen Bearbeitungsprofiltiefe
If a dedicated jaw is being machined:
Sectional drawing to determine the maximum machining depth

für / for TK120531 | TK120531 | TK120529 | TK160554

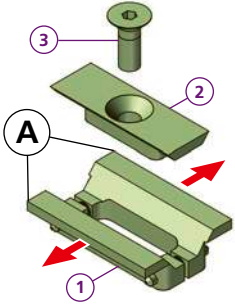
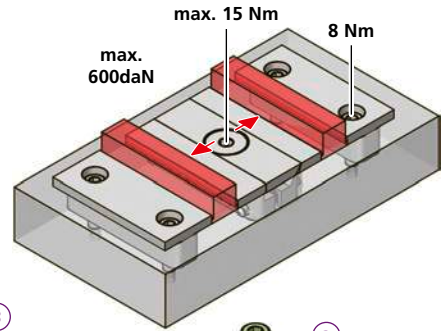

MS2F58L14W251

- 1 2x TK120531
- 2 1x TK120227
- 3 1x M8X22DIN7991

i *

kg ~0,12

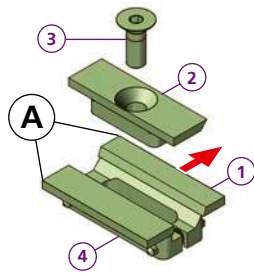

MS1F58L14W251

- 1 1x TK120531
- 2 1x TK120721
- 3 1x M8X22DIN7991
- 4 1x TH130566

i *

kg ~0,12

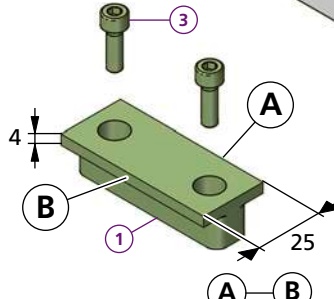

MANF58-14W25

- 1 1x TK120529
- 3 2x M5X16ISO4762
- i *

MANF58-14F25

- 1 1x TK150033
- 3 2x M5X16ISO4762
- i HV700 x 0,2mm

kg ~0,11

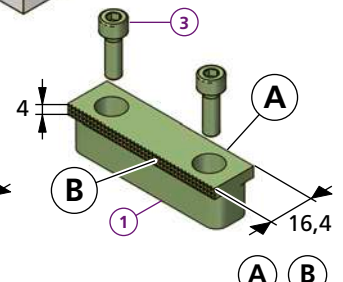

MANF58-14RF

- 1 1x TB160563
- 3 2x M5X16ISO4762

i HV700 x 0,2mm

kg ~0,11

p. 175 Fertigungsmass für die Vorrichtungslatte: / Machining data for the fixture plate:

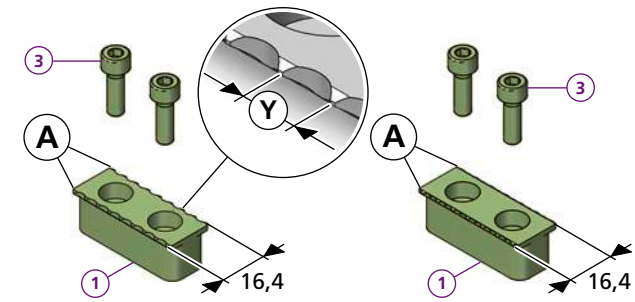

MAND38-14PRG

- 1 1x TB150234
- 3 2x M5X16ISO4762
- Y 4,7 mm

i 57HRC

kg ~0,08

MAND38-14PRG6

- 1 1x TB150283
- 3 2x M5X16ISO4762
- Y 6,0 mm

i 57HRC

kg ~0,08

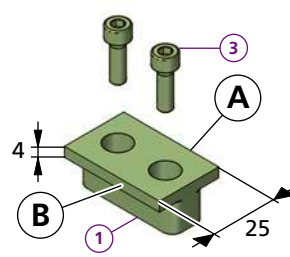

MANF38-14W25

- 1 1x TK160554
- 3 2x M5X16ISO4762
- i *

MANF38-14F25

- 1 1x TK160553
- 3 2x M5X16ISO4762
- i HV700 x 0,2mm

kg ~0,08

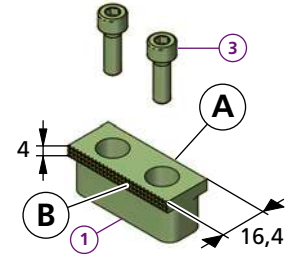

MANF38-14RF

- 1 1x TB170062
- 3 2x M5X16ISO4762

i HV700 x 0,2mm

kg ~0,08

Fertigungsmass für die Vorrichtungslatte
Machining data for the fixture plate

für / for TB150234 | TB150283 | TK160554 | TK160553 | TB170062

Spannmodule

Clamping module MV1F20L35BV1

microCLAMP

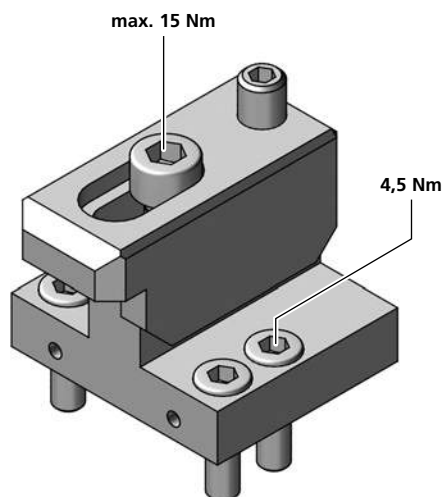
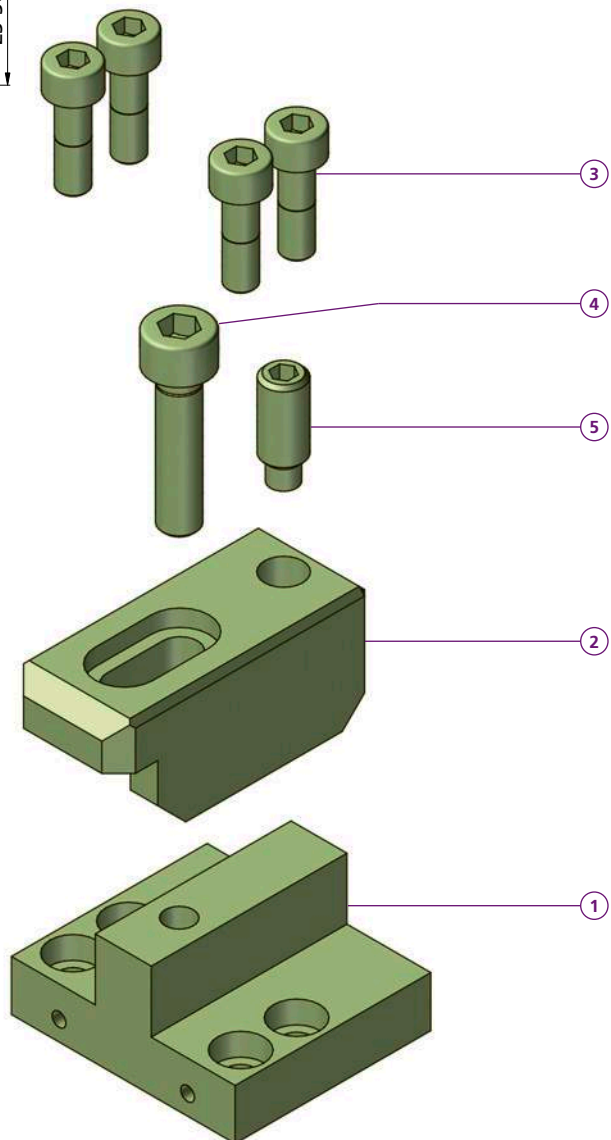
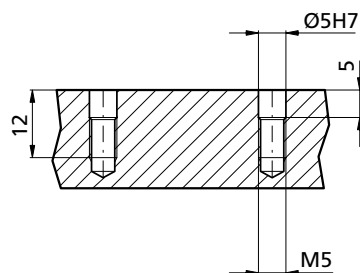
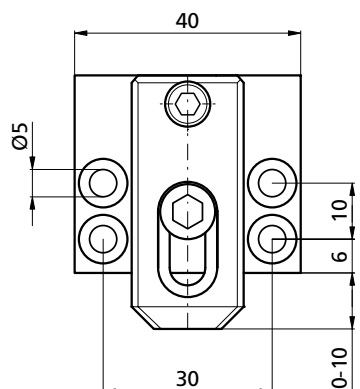
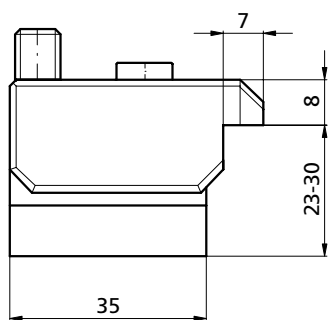
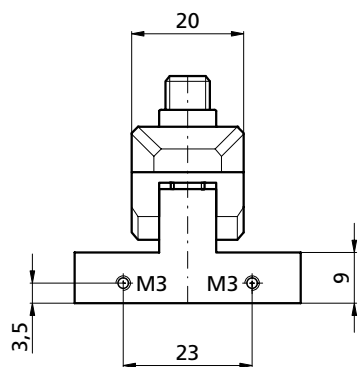

MV1F20L35BV1

- ① 1x TF140710
 - ② 1x BV1
 - ③ 4x M550
 - ④ 1x M6X25ISO4762
 - ⑤ 1x M8x20ISO4028
- kg ~0,225

Bestellbeispiel / Ordering example : MV1F20L35BV1

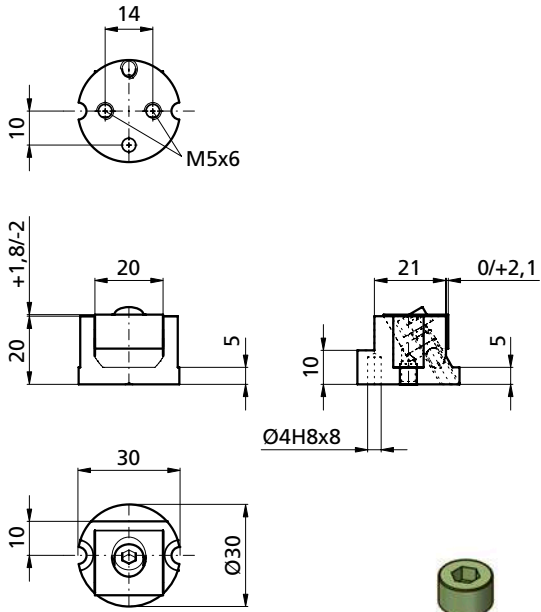

Version 2

Version 1

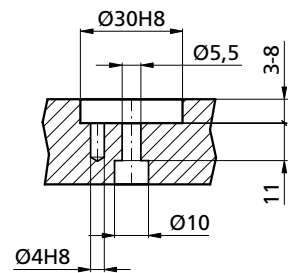
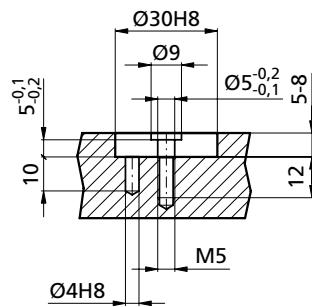
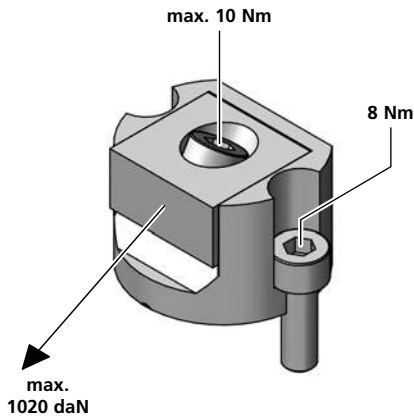
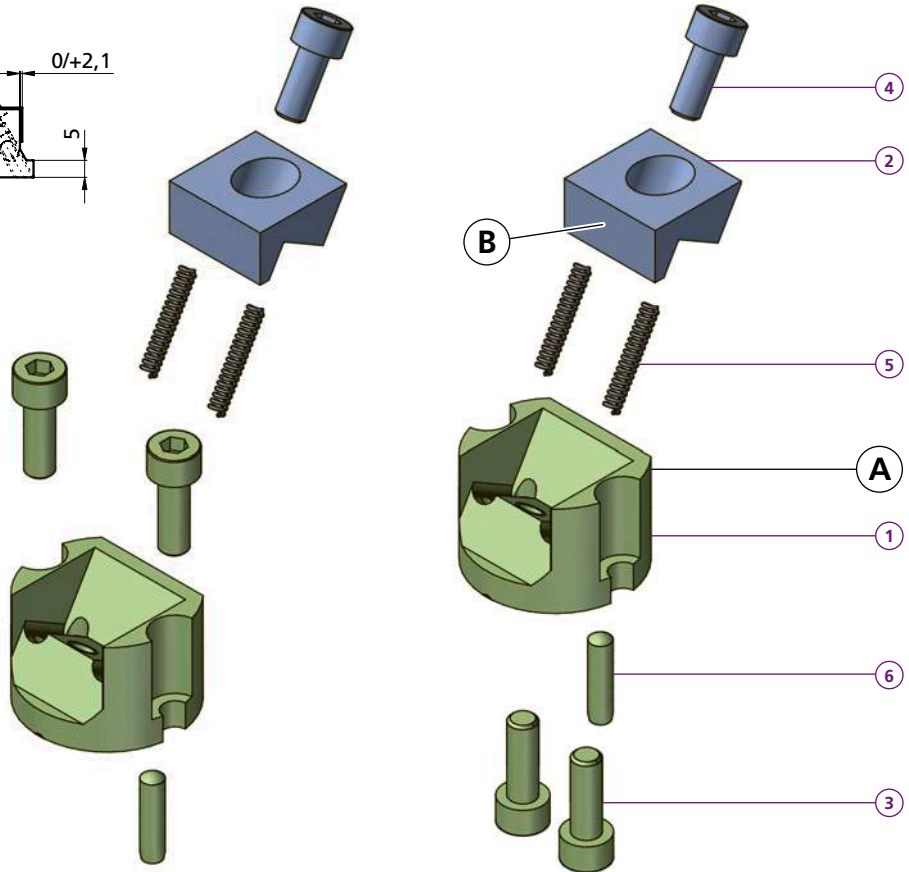

Bestellbeispiel / Ordering example: 1x MR1F30N23-07 & 1x B08

| MR1F30N23-07 | | B07 B08 B09 B09+2 B09+5 | | | | |
|--------------|-------------------|-------------------------|--------|-------|-------|-------|
| 1 | 1x TF140711 | | | | | |
| 2 | 1x | | | | | |
| 3 | 2x M5X16ISO4762 | | | | | |
| 4 | 1x M5X12ISO4762 | | | | | |
| 5 | 2x FED03018 | | | | | |
| 6 | 1x Ø4x14 DIN 6325 | | | | | |
| kg | ~0,095 | | | | | |
| | | C | H | L | D | i |
| | | 20 | 20 | 20 | 20 | 20 |
| | | 10 | 10 | 10 | 10 | 10 |
| | | 9,5 | 9,5 | 9,5 | 11,5 | 14,5 |
| | | 5,5 | 5,5 | 5,5 | 5,5 | 5,5 |
| | | 6 | 6 | 6 | 6 | 6 |
| | | HV700 | HV700 | * | * | * |
| | | x0,2mm | x0,2mm | | | |
| kg | | ~0,02 | ~0,02 | ~0,02 | ~0,02 | ~0,02 |

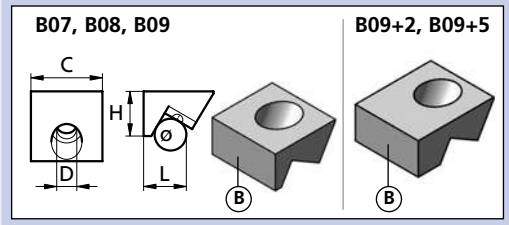

Separat bestellen / Order separately

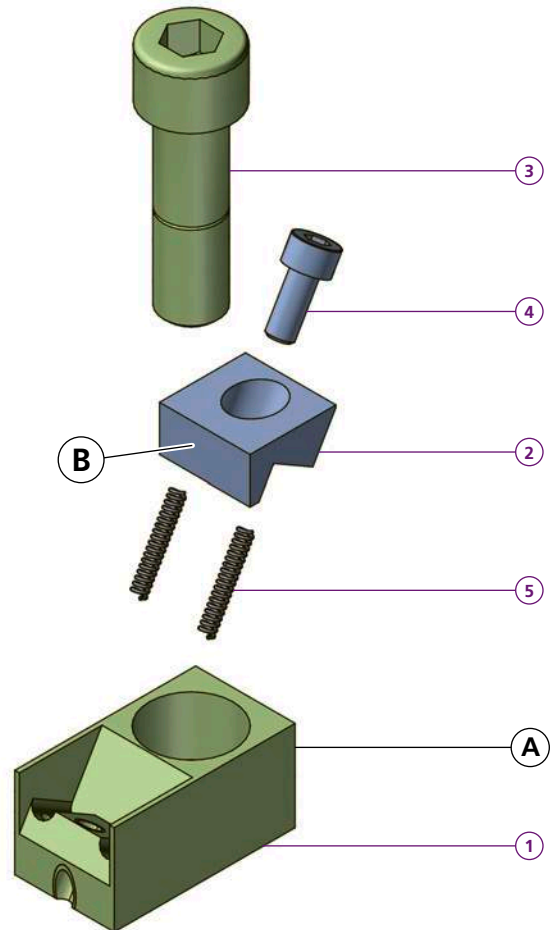
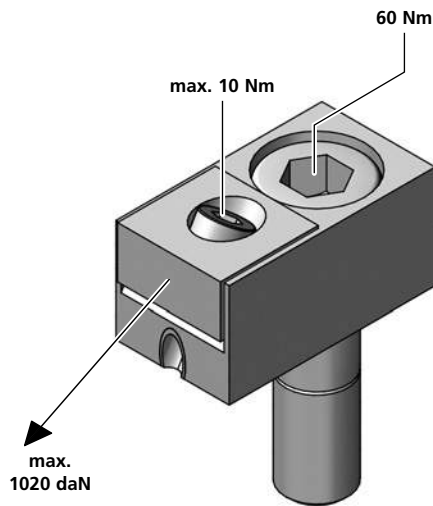
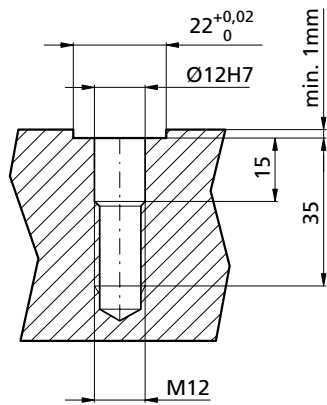
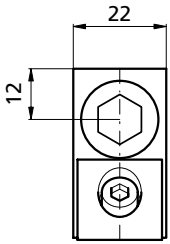
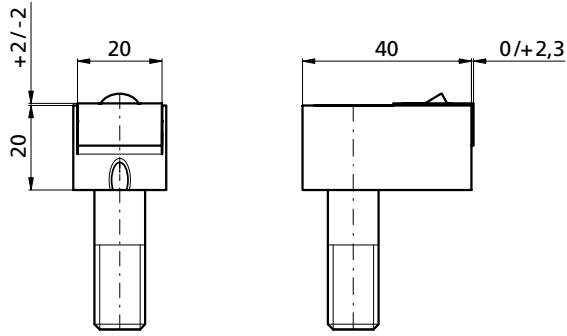

| MS1F22N40-07 | |
|--------------|-----------------|
| 1 | 1x TF140712 |
| 2 | 1x |
| 3 | 1x TWPAS1240 |
| 4 | 1x M5X12ISO4762 |
| 5 | 2x FED03018 |
| kg | ~0,15 |

| Bestellbeispiel / Ordering example: 1x MS1F22N40-07 & 1x B08 | | | | | |
|--|--------|--------|-------|-------|-------|
| | B07 | B08 | B09 | B09+2 | B09+5 |
| C | 20 | 20 | 20 | 20 | 20 |
| H | 10 | 10 | 10 | 10 | 10 |
| L | 9,5 | 9,5 | 9,5 | 11,5 | 14,5 |
| D | 5,5 | 5,5 | 5,5 | 5,5 | 5,5 |
| ø | 6 | 6 | 6 | 6 | 6 |
| i | HV700 | HV700 | * | * | * |
| | x0,2mm | x0,2mm | | | |
| kg | ~0,02 | ~0,02 | ~0,02 | ~0,02 | ~0,02 |

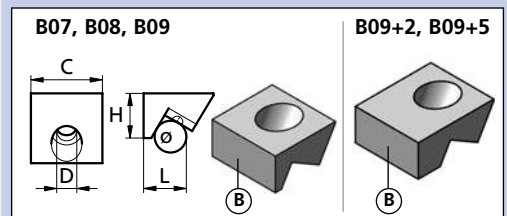

* = weicher Stahl / soft steel

Separat bestellen / Order separately

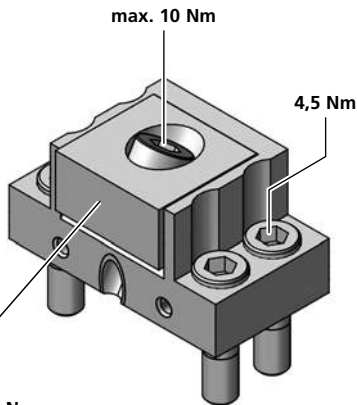
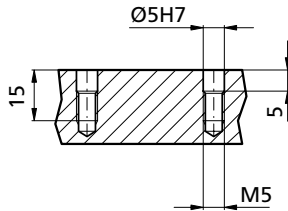
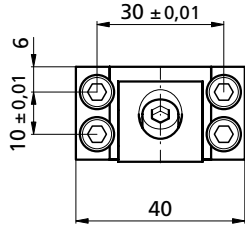
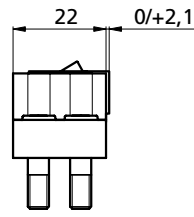
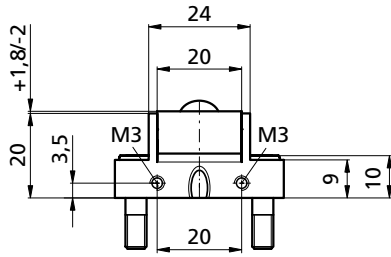

max. 1020 daN

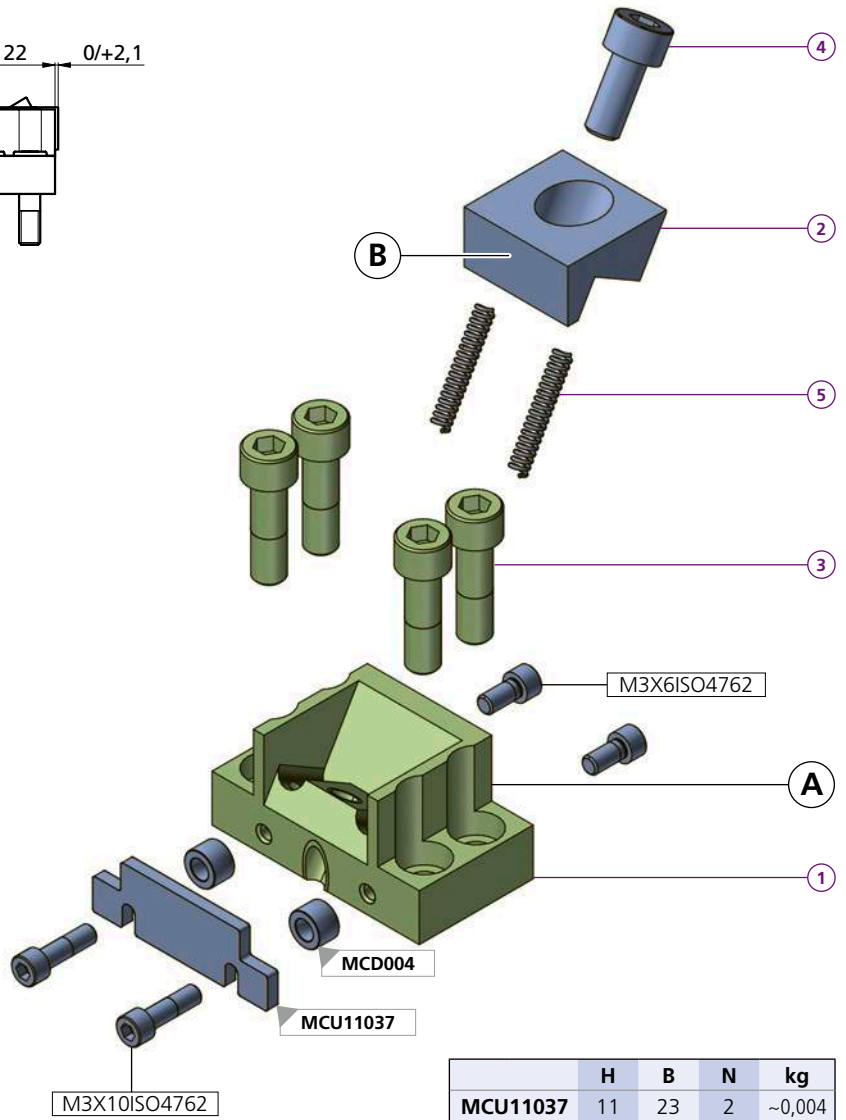

| | H | B | N | kg |
|----------|------|----|---|--------|
| MCU11037 | 11 | 23 | 2 | ~0,004 |
| MCU15037 | 15 | 23 | 2 | ~0,006 |
| MCU18037 | 18 | 23 | 2 | ~0,008 |
| MCU20037 | 20 | 23 | 2 | ~0,008 |
| MCU22537 | 22,5 | 23 | 2 | ~0,008 |

- 2x M3X10ISO4762
- 2x M3X6ISO4762
- 2x MCD004

Achtung: Bei Spannkraften über 400 daN (0,4t) muss das Spannmodul in eine Nut eingelassen werden (Nuttiefe mindestens 1mm)

Remark: Using forces higher than 400 daN, clamps must be mounted into a slot (depth minimum 1mm)

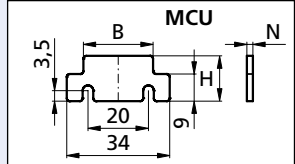
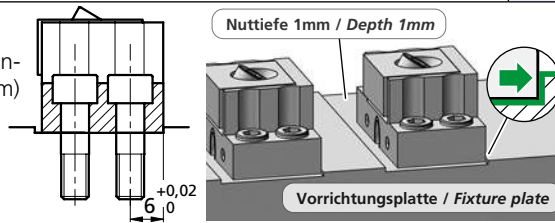

| MS1F24N22-07 | |
|--------------|-----------------|
| 1 | 1x TF140713 |
| MS1R24N22-07 | |
| 1 | 1x TW100172-01 |
| 2 | 1x |
| 3 | 4x MS50 |
| 4 | 1x M5X12ISO4762 |
| 5 | 2x FED03018 |
| kg | ~0,125 |

| Bestellbeispiel / Ordering example: 1x MS1F24N22-07 & 1x B08 | | | | | |
|--|-----------------|-----------------|-------|-------|-------|
| | B07 | B08 | B09 | B09+2 | B09+5 |
| C | 20 | 20 | 20 | 20 | 20 |
| H | 10 | 10 | 10 | 10 | 10 |
| L | 9,5 | 9,5 | 9,5 | 11,5 | 14,5 |
| D | 5,5 | 5,5 | 5,5 | 5,5 | 5,5 |
| ø | 6 | 6 | 6 | 6 | 6 |
| i | HV700 x0,2mm | HV700 x0,2mm | * | * | * |
| kg | ~0,02 | ~0,02 | ~0,02 | ~0,02 | ~0,02 |

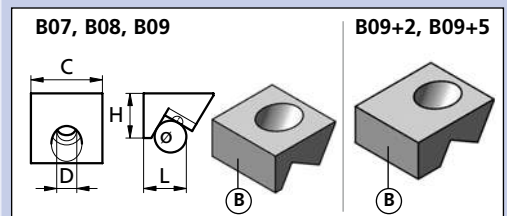

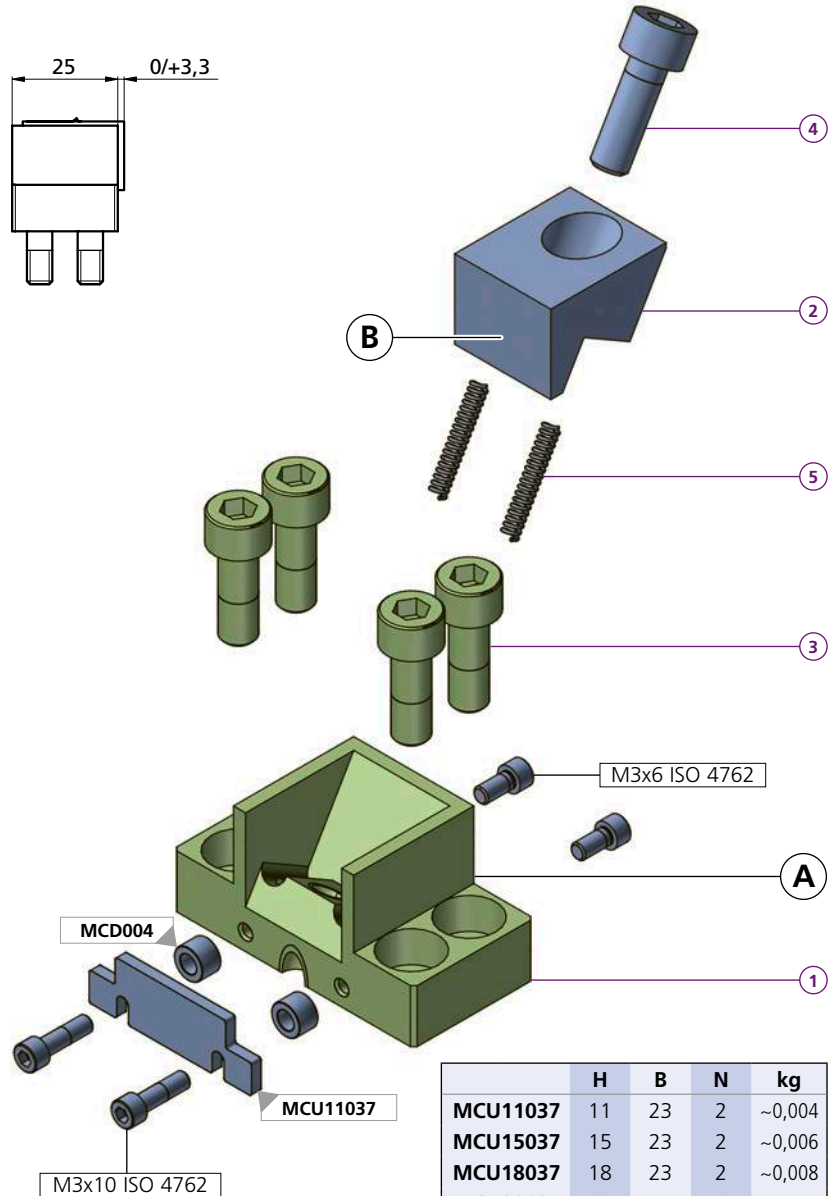
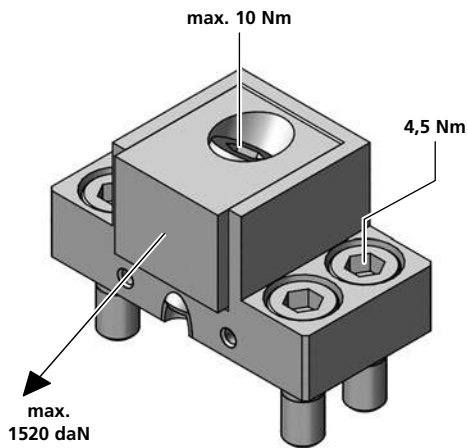
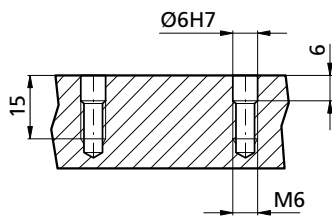
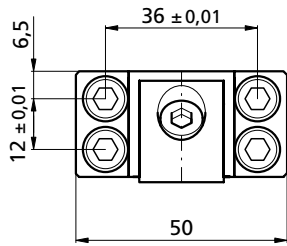
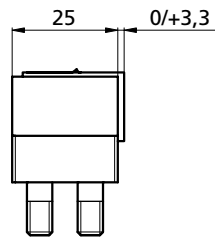
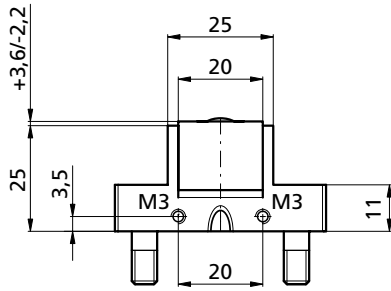

| | H | B | N | kg |
|----------|------|----|---|--------|
| MCU11037 | 11 | 23 | 2 | ~0,004 |
| MCU15037 | 15 | 23 | 2 | ~0,006 |
| MCU18037 | 18 | 23 | 2 | ~0,008 |
| MCU20037 | 20 | 23 | 2 | ~0,008 |
| MCU22537 | 22,5 | 23 | 2 | ~0,008 |

- 2x M3X10ISO4762
- 2x M3X6ISO4762
- 2x MCD004

Achtung: Bei Spannkraften über 400 daN (0,4t) muss das Spannmodul in eine Nut eingelassen werden (Nuttiefe mindestens 1mm)

Remark: Using forces higher than 400 daN, clamps must be mounted into a slot (depth minimum 1mm)

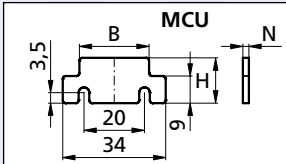
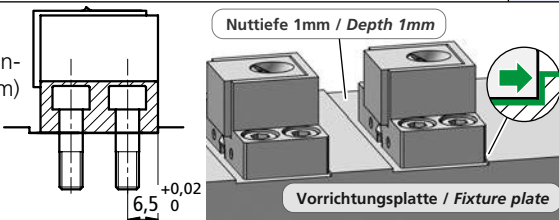

| MS1F25N25-13 | |
|--------------|-----------------|
| 1 | 1x TF140714 |
| MS1R25N25-13 | |
| 1 | 1x TF140715 |
| 2 | 1x |
| 3 | 4x MS60 |
| 4 | 1x M6X16ISO4762 |
| 5 | 2x FED03018 |
| kg | ~0,165 |

Bestellbeispiel / Ordering example: 1x MS1F25N25-13 & 1x B14

| | B13 | B14 | B15 | B16 |
|----|--------|--------|-------|-------|
| C | 20 | 20 | 20 | 20 |
| H | 16 | 16 | 16 | 16 |
| L | 13,8 | 13,8 | 13,8 | 19 |
| D | 6,5 | 6,5 | 6,5 | 6,5 |
| ø | 10 | 10 | 10 | 10 |
| i | HV700 | HV700 | * | * |
| | x0,2mm | x0,2mm | | |
| kg | ~0,05 | ~0,05 | ~0,05 | ~0,06 |

| | B13, B14, B15 | B16 |
|---|---------------|-----|
| B | 23 | 23 |

* = weicher Stahl / soft steel

MS1R/F35N14-01

MS1F35N22-01

microCLAMP

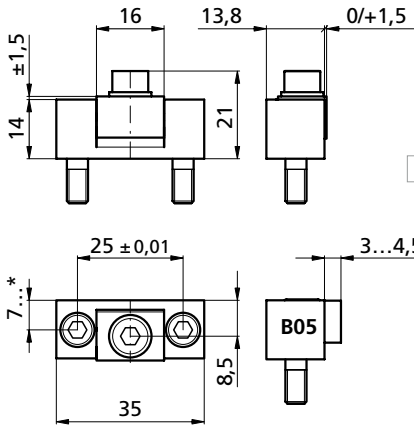

MS1F35N14-01

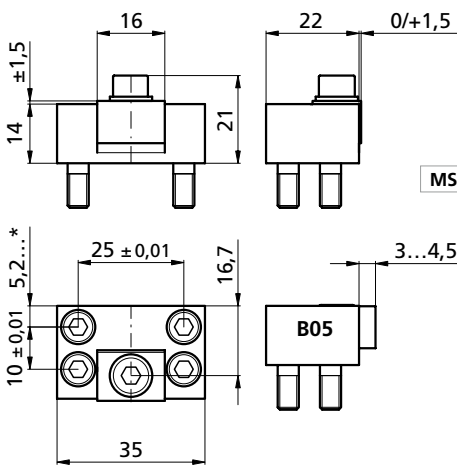
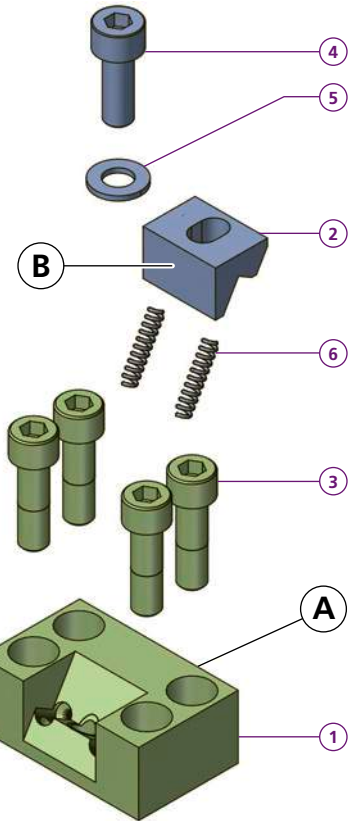
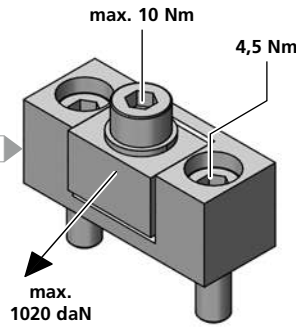

MS1F35N22-01

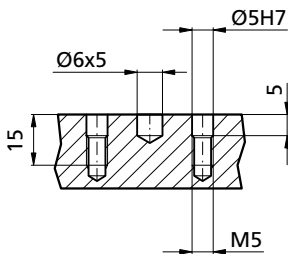
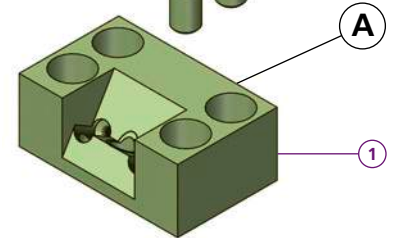
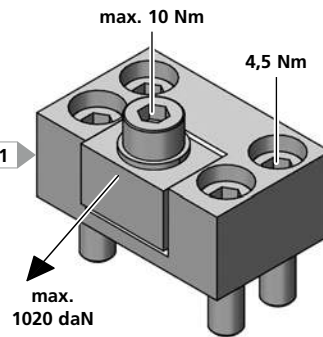

Beim Einsatz der Backe B05(R) Jaw B05(R) in use
 Nachbearbeitung am Modul, falls If a stroke of 1,1mm to 1,5mm der gesamte Backenhub (1,1mm bis is required the module must be 1,5mm) benötigt wird. machined according to this sketch.

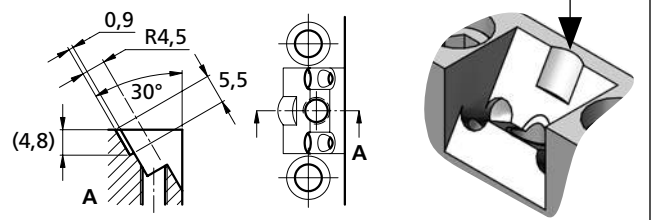

Achtung: Bei Spannkraften über 400 daN (0,4t) muss das Spannmodul in eine Nut eingelassen werden (Nuttiefe mindestens 1mm)

Remark: Using forces higher than 400 daN, clamps must be mounted into a slot (depth minimum 1mm)

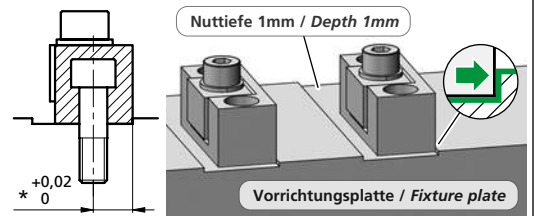

| | |
|---------------------|----------|
| MS1F35N14-01 | A |
| 1x TF140718 | |
| MS1R35N14-01 | B |
| 1x TK190150 | |
| 1x | |
| 2x MS50 | |
| 1x M5X14ISO4762 | |
| 1x 5x10x1DIN125A | |
| 2x FED02813 | |
| kg ~0,05 | |
| MS1F35N22-01 | A |
| 1x TF140719 | |
| 4x MS50 | |
| kg ~0,08 | |

Bestellbeispiel / Ordering example: 1x MS1F35N14-01 & 1x B02

| | B01 | B02 | B03 | B04 | B05 | B05R |
|----------|--------|--------|--------|---------|--------|--------|
| C | 16 | 16 | 16 | 16 | 16 | 16 |
| H | 10 | 10 | 10 | 10 | 10 | 10 |
| L | 8 | 8 | 11 | 8 | 10 | 10 |
| D | 5,5 | 5,5 | 5,5 | 5,5 | 5,2 | 5,2 |
| e | 4 | 4 | 4 | 4 | 4 | 4 |
| i | HV700 | HV700 | * | Messing | HV700 | HV700 |
| | x0,2mm | x0,2mm | | Laiton | x0,2mm | x0,2mm |
| kg | ~0,01 | ~0,01 | ~0,014 | ~0,012 | ~0,014 | ~0,014 |

M5X10DIN6912

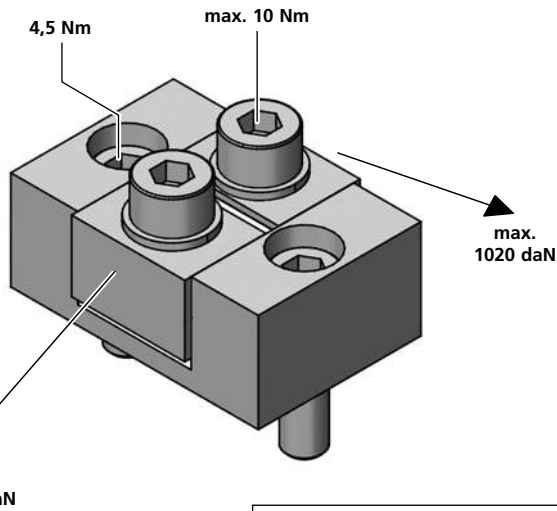
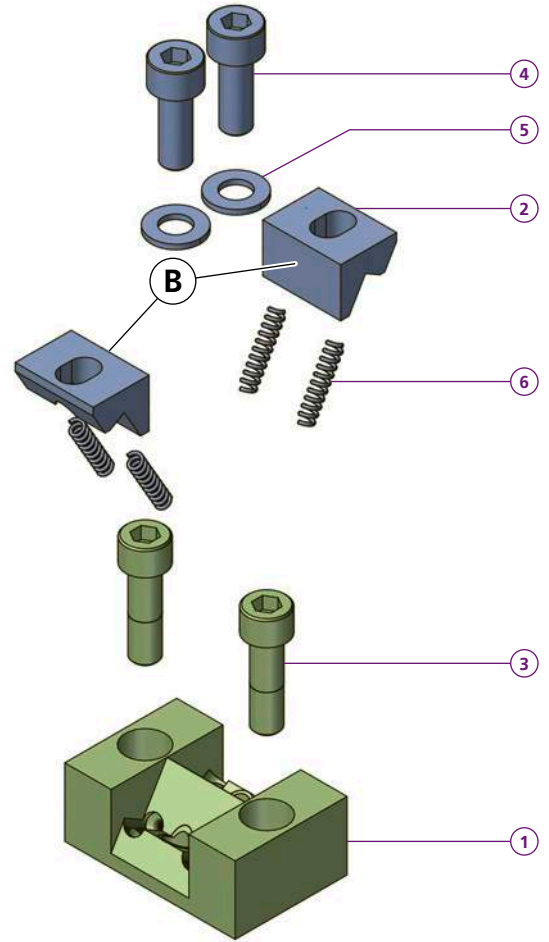
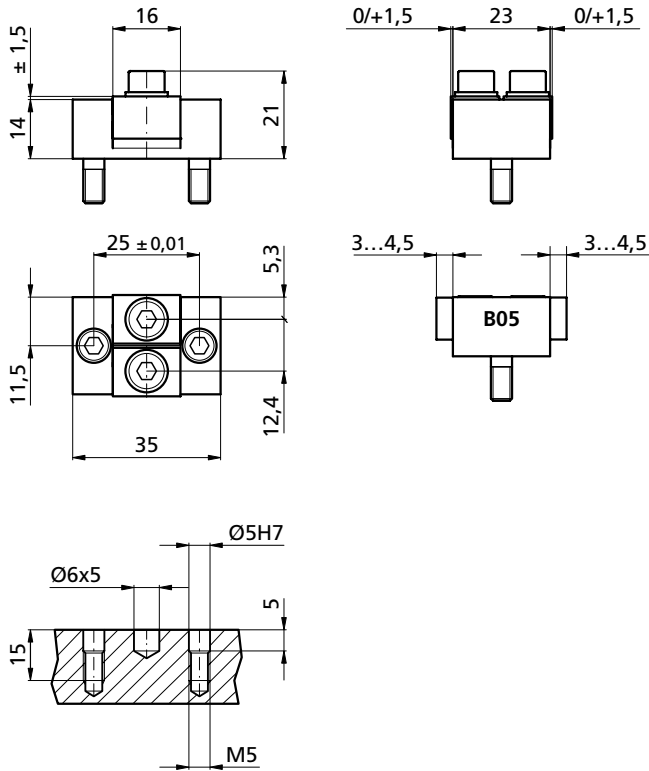

Beim Einsatz der Backe B05(R) Jaw B05(R) in use
 Nachbearbeitung am Modul, falls If a stroke of 1,1mm to 1,5mm
 der gesamte Backenhub (1,1mm bis is required the module must be
 1,5mm) benötigt wird. machined according to this sketch.

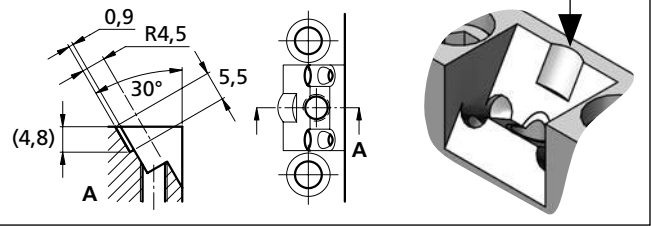

Achtung: Bei Spannkraften über 400 daN (0,4t) muss das Spannmodul in eine Nut eingelassen werden (Nuttiefe mindestens 1mm)

Remark: Using forces higher than 400 daN, clamps must be mounted into a slot (depth minimum 1mm)

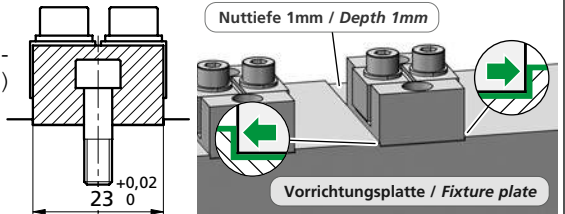

Bestellbeispiel / Ordering example: 1x MS2X35N23-01 & 2x B02

| MS2X35N23-01 | |
|--------------|------------------|
| 1 | 1x TF140720 |
| 2 | 2x |
| 3 | 2x MS50 |
| 4 | 2x M5X14ISO4762 |
| 5 | 2x 5x10x1DIN125A |
| 6 | 4x FED02813 |
| kg | ~0,085 |

| | B01 | B02 | B03 | B04 | B05 | B05R |
|----|-----------------|-----------------|--------|-------------------|-----------------|-----------------|
| C | 16 | 16 | 16 | 16 | 16 | 16 |
| H | 10 | 10 | 10 | 10 | 10 | 10 |
| L | 8 | 8 | 11 | 8 | 10 | 10 |
| D | 5,5 | 5,5 | 5,5 | 5,5 | 5,2 | 5,2 |
| e | 4 | 4 | 4 | 4 | 4 | 4 |
| i | HV700 x0,2mm | HV700 x0,2mm | * | Messing Laiton | HV700 x0,2mm | HV700 x0,2mm |
| kg | ~0,01 | ~0,01 | ~0,014 | ~0,012 | ~0,014 | ~0,014 |

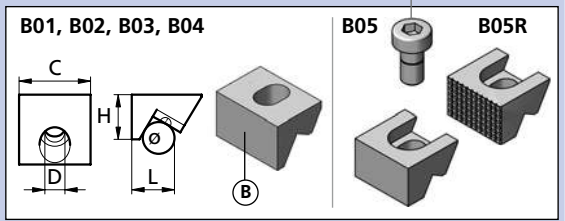

* = weicher Stahl / soft steel

Separat bestellen / Order separately

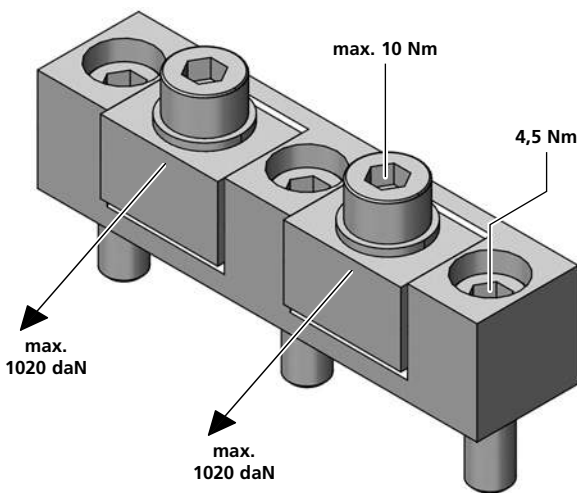
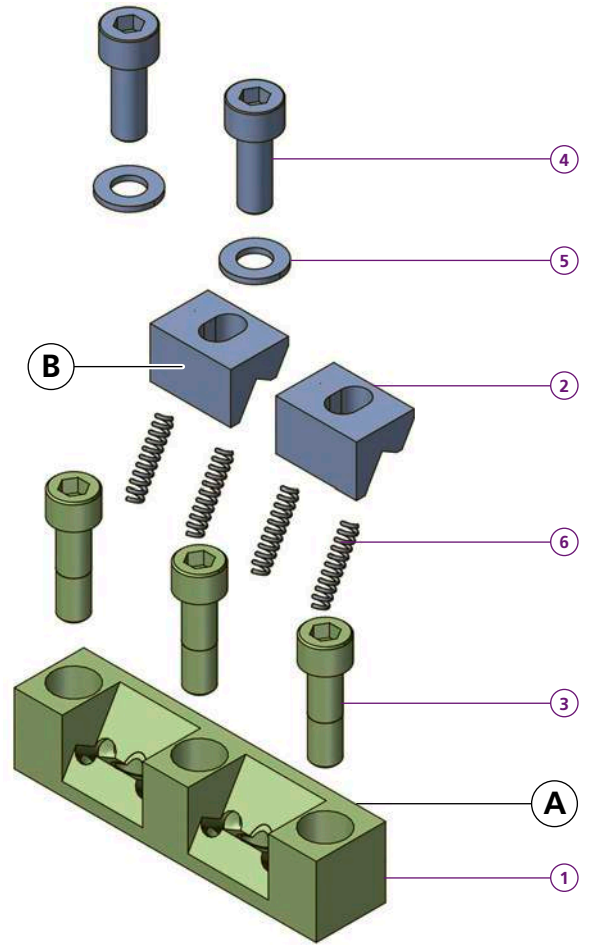
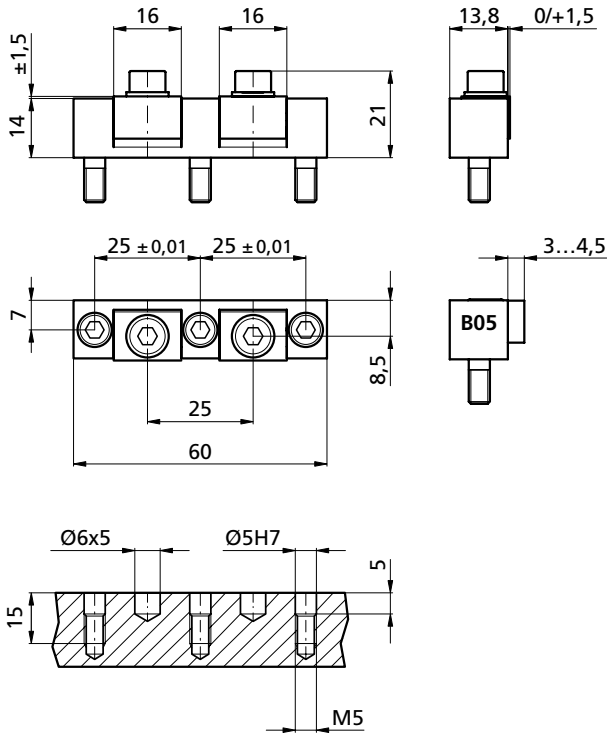

Beim Einsatz der Backe B05(R) Jaw B05(R) in use
 Nachbearbeitung am Modul, falls If a stroke of 1,1mm to 1,5mm
 der gesamte Backenhub (1,1mm bis is required the module must be
 1,5mm) benötigt wird. machined according to this sketch.

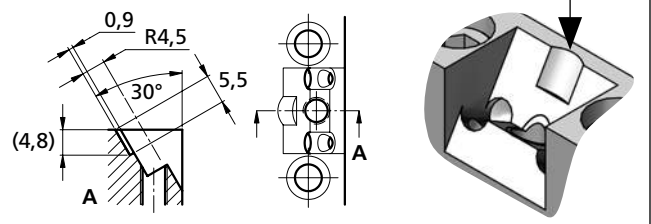

Achtung: Bei Spannkraften über 400 daN (0,4t) muss das Spannmodul in eine Nut eingelassen werden (Nuttiefe mindestens 1mm)
Remark: Using forces higher than 400 daN, clamps must be mounted into a slot (depth minimum 1mm)

Bestellbeispiel / Ordering example: 1x MS2F60N14-01 & 2x B02

| MS2F60N14-01 | B01 | B02 | B03 | B04 | B05 | B05R |
|------------------|----------|----------|-----------|-----------|-----------|-----------|
| 1x TF140721 | | | | | | |
| 2x | | | | | | |
| 3x MS50 | | | | | | |
| 2x M5X14ISO4762 | | | | | | |
| 2x 5x10x1DIN125A | | | | | | |
| 4x FED02813 | | | | | | |
| kg ~0,09 | kg ~0,01 | kg ~0,01 | kg ~0,014 | kg ~0,012 | kg ~0,014 | kg ~0,014 |

MSX10DIN6912

| | B01, B02, B03, B04 | B05 | B05R |
|---|--------------------|--------|---------|
| C | 16 | 16 | 16 |
| H | 10 | 10 | 10 |
| L | 8 | 8 | 10 |
| D | 5,5 | 5,5 | 5,2 |
| ø | 4 | 4 | 4 |
| i | HV700 | HV700 | Messing |
| | x0,2mm | x0,2mm | Laiton |
| | | | x0,2mm |

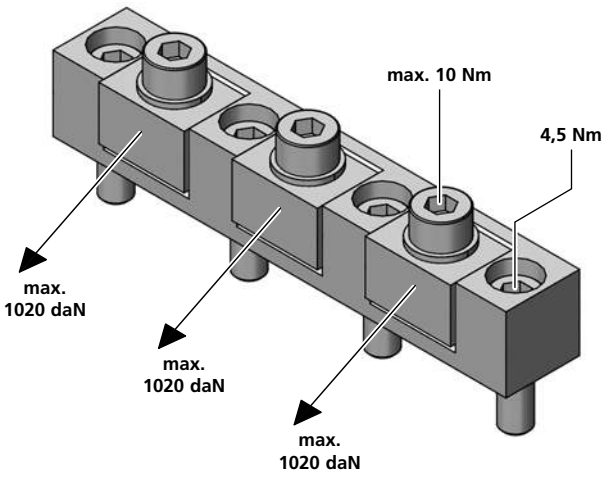
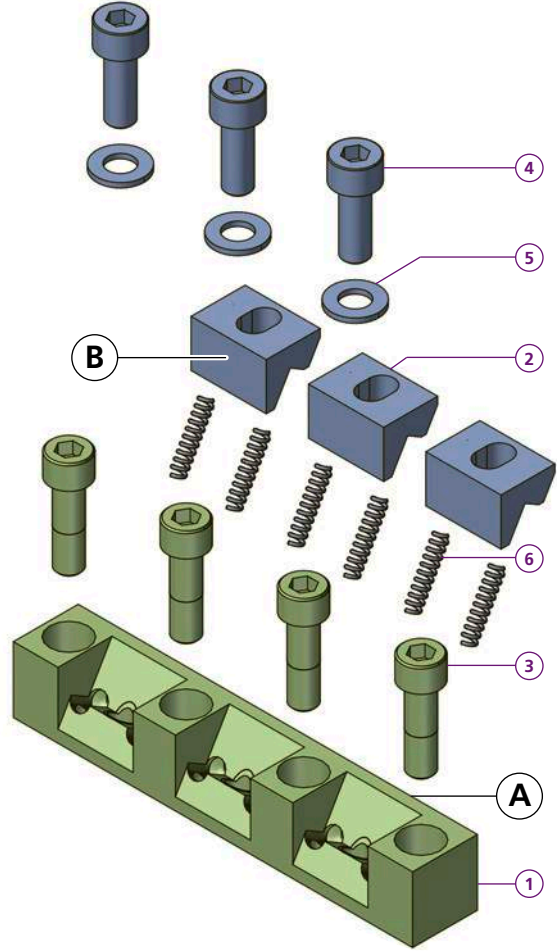
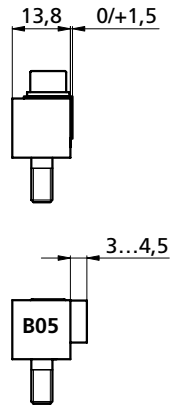
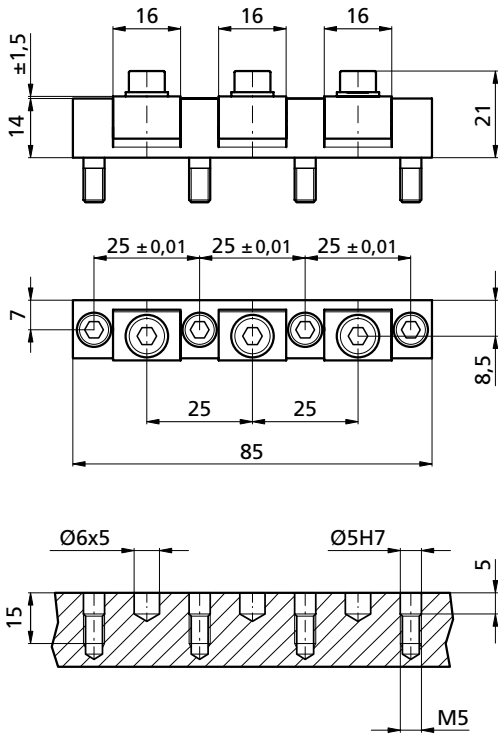

Beim Einsatz der Backe B05(R) Jaw B05(R) in use
 Nachbearbeitung am Modul, falls If a stroke of 1,1mm to 1,5mm
 der gesamte Backenhub (1,1mm bis is required the module must be
 1,5mm) benötigt wird. machined according to this sketch.

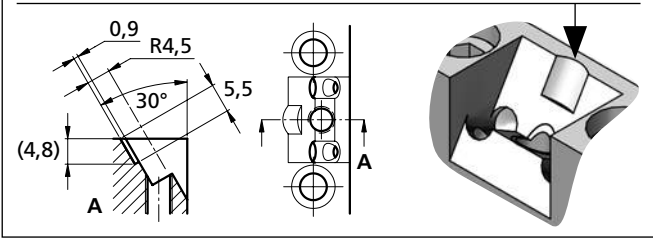

Achtung: Bei Spannkraften über 400 daN (0,4t) muss das Spannmodul in eine Nut eingelassen werden (Nuttiefe mindestens 1mm)
Remark: Using forces higher than 400 daN, clamps must be mounted into a slot (depth minimum 1mm)

Bestellbeispiel / Ordering example: 1x MS3F85N14-01 & 3x B02

| MS3F85N14-01 | B01 | B02 | B03 | B04 | B05 | B05R |
|------------------|----------|----------|-----------|-----------|-----------|-----------|
| 1x TH160579 | 16 | 16 | 16 | 16 | 16 | 16 |
| 3x | 10 | 10 | 10 | 10 | 10 | 10 |
| 4x MS50 | 8 | 8 | 11 | 8 | 10 | 10 |
| 3x M5X14ISO4762 | 5,5 | 5,5 | 5,5 | 5,5 | 5,2 | 5,2 |
| 3x 5x10x1DIN125A | 4 | 4 | 4 | 4 | 4 | 4 |
| 6x FED02813 | HV700 | HV700 | * | Messing | HV700 | HV700 |
| | x0,2mm | x0,2mm | | Laiton | x0,2mm | x0,2mm |
| kg ~0,125 | kg ~0,01 | kg ~0,01 | kg ~0,014 | kg ~0,012 | kg ~0,014 | kg ~0,014 |

M5X10DIN6912

* = weicher Stahl / soft steel

Separat bestellen / Order separately

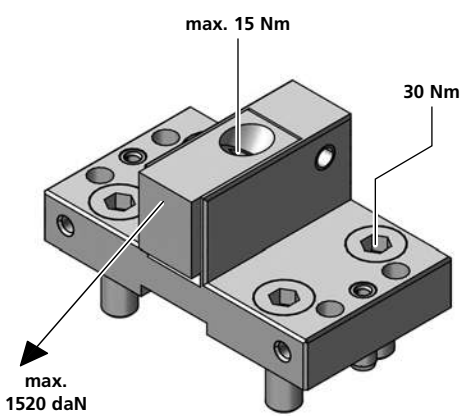
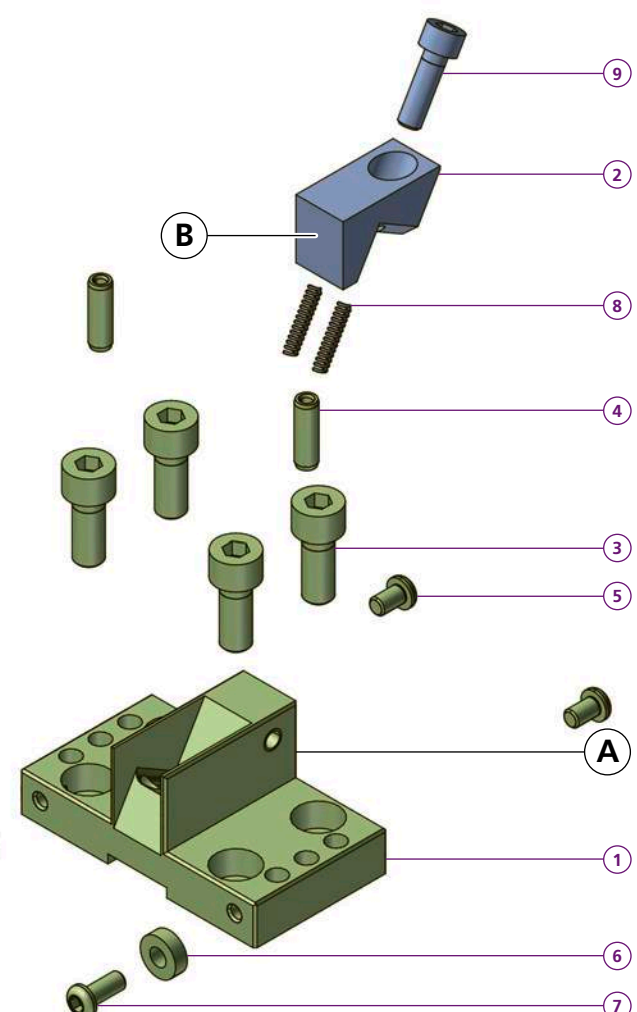
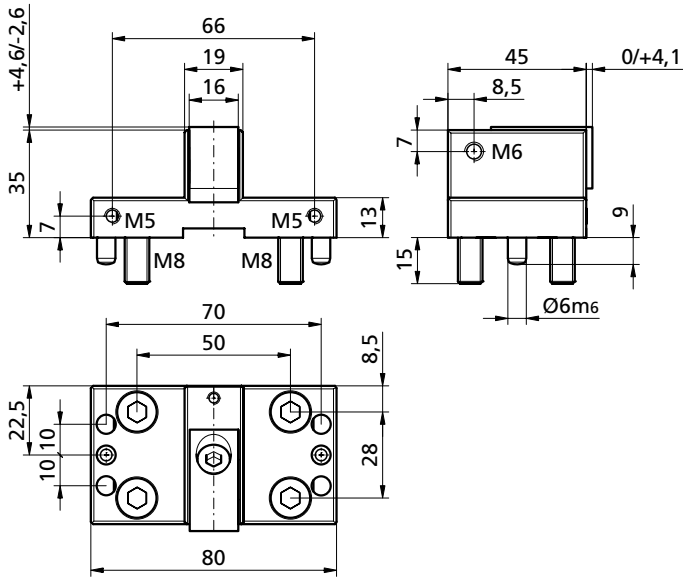

| | |
|---------------------|-----------------|
| VS1F19N35-20 | |
| 1 | 1x TF150029 |
| VS1R19N35-20 | |
| 1 | 1x TF140723 |
| 2 | 1x |
| 3 | 4x M8X20ISO4762 |
| 4 | 2x CCBO0802 |
| 5 | 2x M5X8ISO7380 |
| 6 | 2x CCD004 |
| 7 | 2x M5X12ISO7380 |
| 8 | 2x FED0418 |
| 9 | 1x M6X20ISO4762 |
| kg | ~0,505 |

Bestellbeispiel / Ordering example: 1x VS1R19N35-20 & 1x B21

| | B20 | B21 | B22 |
|----|--------|--------|--------|
| C | 16 | 16 | 16 |
| H | 20 | 20 | 20 |
| L | 19 | 19 | 19 |
| D | 6,5 | 6,5 | 6,5 |
| ø | 12 | 12 | 12 |
| i | HV700 | HV700 | * |
| | x0,2mm | x0,2mm | |
| kg | ~0,011 | ~0,011 | ~0,011 |

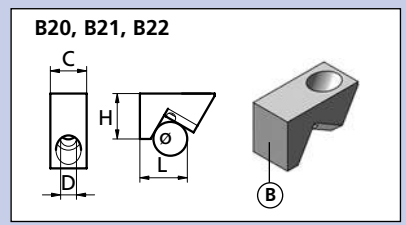

Separat bestellen / Order separately

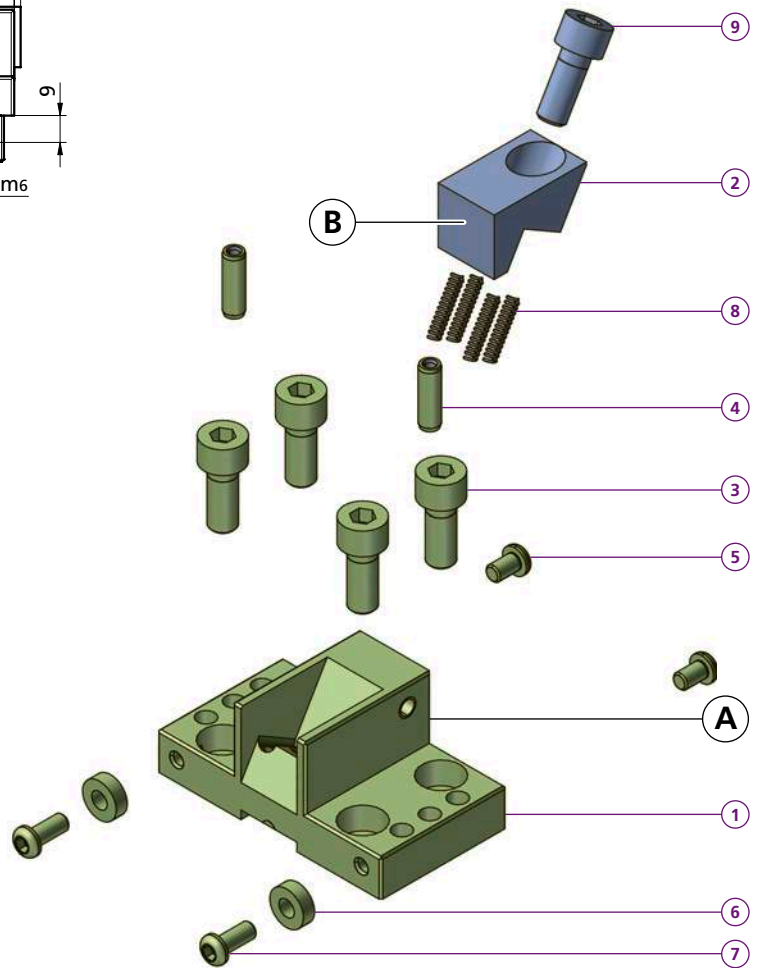
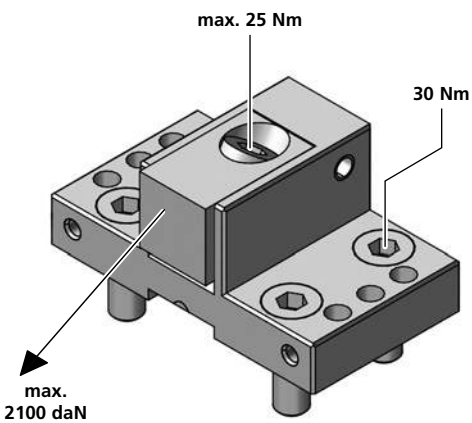
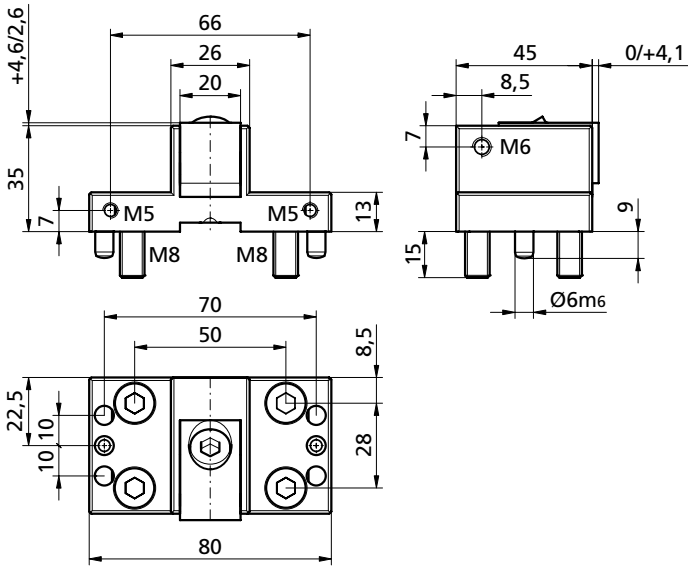

| VS1R26N35-26 | |
|--------------|-----------------|
| 1 | 1x TF140725 |
| 2 | 1x |
| 3 | 4x M8X20ISO4762 |
| 4 | 2x CCBO0802 |
| 5 | 2x M5X8ISO7380 |
| 6 | 2x CCD004 |
| 7 | 2x M5X12ISO7380 |
| 8 | 4x FED0418 |
| 9 | 1x M8X20ISO4762 |
| kg | ~0,55 |

* = weicher Stahl / soft steel

Bestellbeispiel / Ordering example: 1x VS1R26N35-26 & 1x B27

| | B26 | B27 | B28 |
|----|-----------------|-----------------|--------|
| C | 20 | 20 | 20 |
| H | 20 | 20 | 20 |
| L | 19 | 19 | 19 |
| D | 9 | 9 | 9 |
| ø | 12 | 12 | 12 |
| i | HV700 x0,2mm | HV700 x0,2mm | * |
| kg | ~0,064 | ~0,064 | ~0,064 |

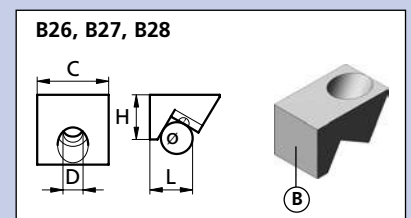

Separat bestellen / Order separately

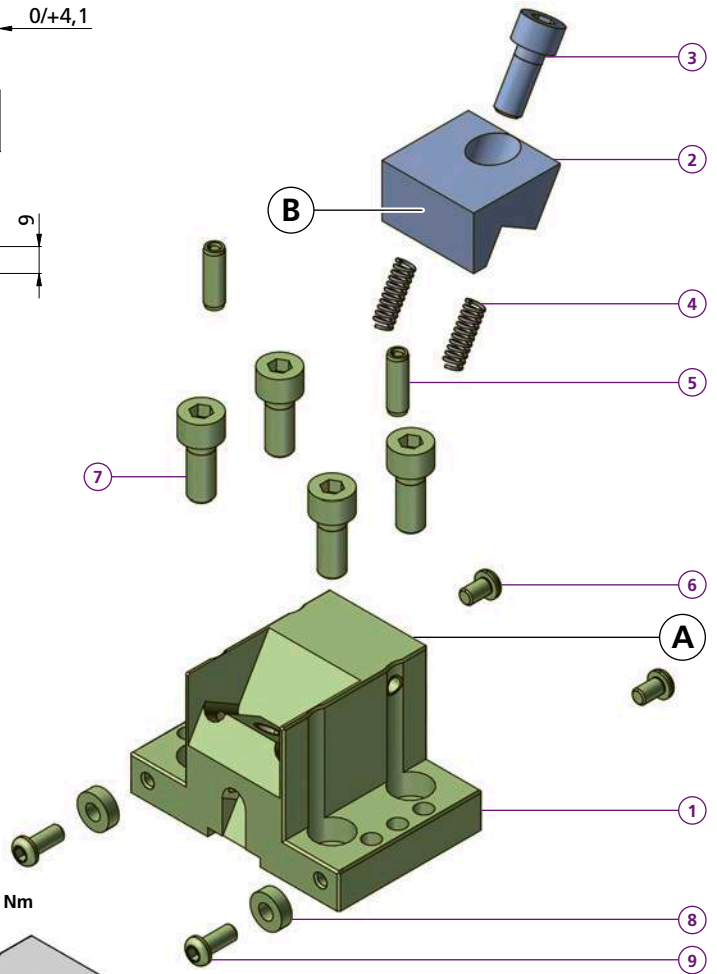
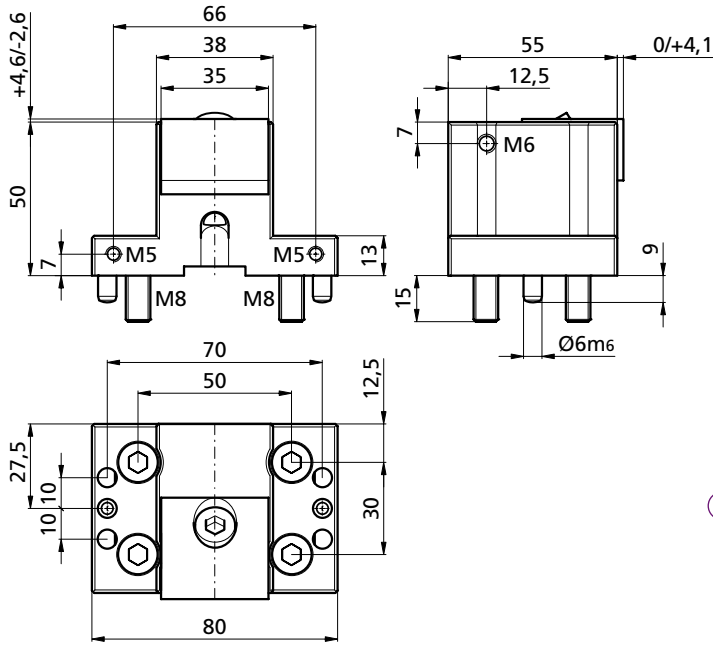

VS1R38N50-60

- 1x TF140726
- 1x M8X20ISO4762
- 2x FED0618
- 2x CCBO0802
- 2x M5X8ISO7380
- 4x M8X20ISO4762
- 2x CCD004
- 2x M5X12ISO7380

kg ~1,01

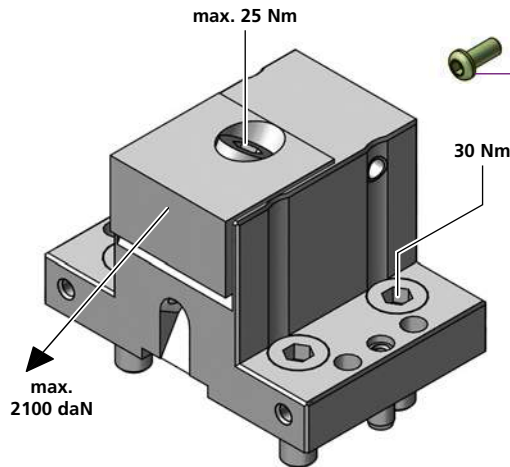

Bestellbeispiel / Ordering example: 1x VS1R38N50-60 & 1x B61

| | B58 | B60 | B61 | B62 | B62HM | B65 | B66 | B67 | B68 | B69 | B77 | B79F | B79R |
|----|-------|-------|-------|-------|-------|-----------------|-----------------|-----------------|-------|-------|-------|-----------------|-----------------|
| C | 35 | 35 | 35 | 35 | 35 | 35 | 35 | 35 | 35 | 35 | 35 | 35 | 35 |
| H | 20 | 20 | 20 | 20 | 20 | 20 | 20 | 20 | 20 | 25 | 20 | 20 | 20 |
| L | 26 | 19 | 19 | 19 | 19 | 19 | 19 | 24 | 26 | 22 | 22 | 25 | 25 |
| D | 9 | 9 | 9 | 9 | 9 | 9 | 9 | 9 | 9 | 9 | 9 | 9 | 9 |
| ø | 12 | 12 | 12 | 12 | 12 | 12 | 12 | 12 | 12 | 12 | 12 | 12 | 12 |
| i | ALU | 56HRC | 56HRC | * | HM | HV700 x0,2mm | HV700 x0,2mm | HV700 x0,2mm | * | * | 56HRC | HV700 x0,2mm | HV700 x0,2mm |
| kg | ~0,07 | ~0,12 | ~0,12 | ~0,12 | ~0,12 | ~0,12 | ~0,12 | ~0,14 | ~0,15 | ~0,15 | ~0,12 | ~0,18 | ~0,18 |

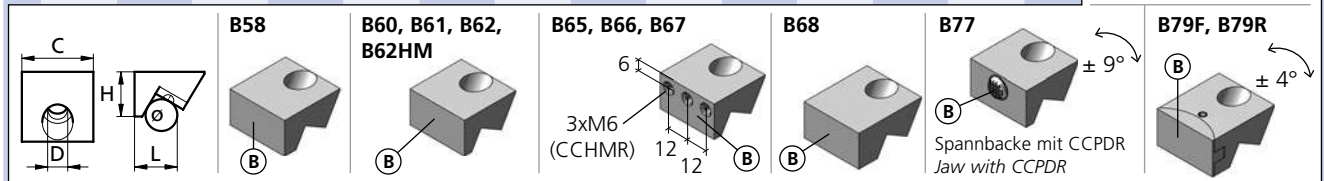
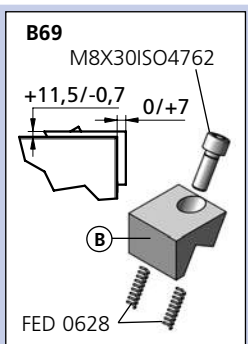

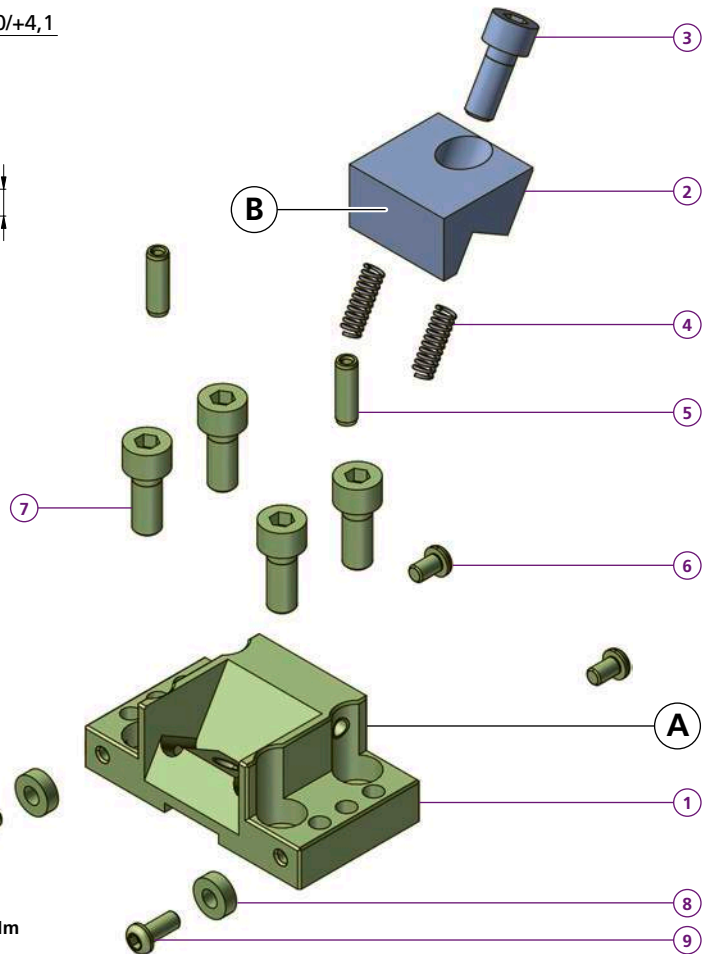
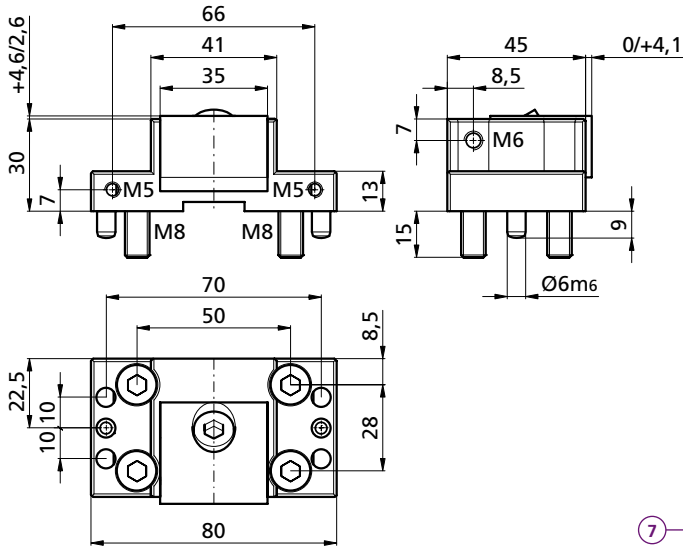

- VS1F41N30-60**
- 1x TF140729
- VS1R41N30-60**
- 1x TF140730
- 1x
- 1x M8X20ISO4762
- 2x FED0618
- 2x CCBO0802
- 2x M5X8ISO7380
- 4x M8X20ISO4762
- 2x CCD004
- 2x M5X12ISO7380
- kg ~0,58

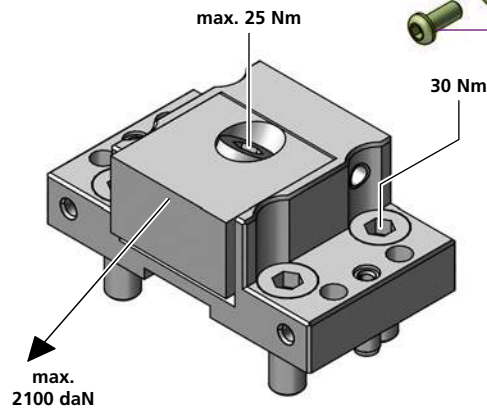

Bestellbeispiel / Ordering example: 1x VS1R41N30-60 & 1x B61

| | B58 | B60 | B61 | B62 | B62HM | B65 | B66 | B67 | B68 | B77 | B79F | B79R |
|----|-------|--------|--------|-------|-------|--------|--------|--------|-------|-------|--------|--------|
| C | 35 | 35 | 35 | 35 | 35 | 35 | 35 | 35 | 35 | 35 | 35 | 35 |
| H | 20 | 20 | 20 | 20 | 20 | 20 | 20 | 20 | 20 | 20 | 20 | 20 |
| L | 26 | 19 | 19 | 19 | 19 | 19 | 19 | 24 | 26 | 22 | 25 | 25 |
| D | 9 | 9 | 9 | 9 | 9 | 9 | 9 | 9 | 9 | 9 | 9 | 9 |
| ø | 12 | 12 | 12 | 12 | 12 | 12 | 12 | 12 | 12 | 12 | 12 | 12 |
| i | ALU | 56HRC | 56HRC | * | HM | HV700 | HV700 | HV700 | * | 56HRC | HV700 | HV700 |
| | | x0,2mm | x0,2mm | | | x0,2mm | x0,2mm | x0,2mm | | | x0,2mm | x0,2mm |
| kg | ~0,07 | ~0,12 | ~0,12 | ~0,12 | ~0,12 | ~0,12 | ~0,12 | ~0,14 | ~0,15 | ~0,12 | ~0,18 | ~0,18 |

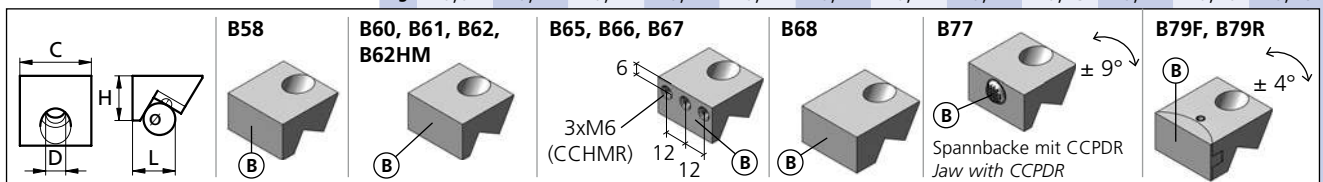

* = weicher Stahl / soft steel

HM = Hartmetallbeschichtet / Carbide coated

ALU = ENAW-7022

VS1R/F80N30-36

VS1R80N50-36

microCLAMP

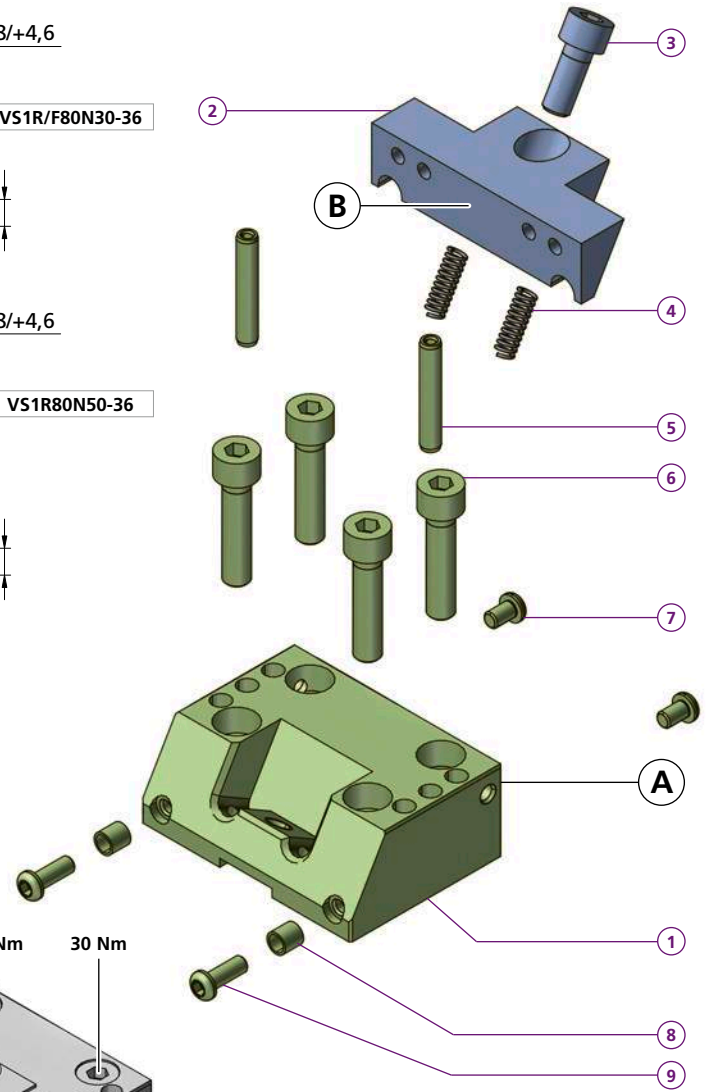
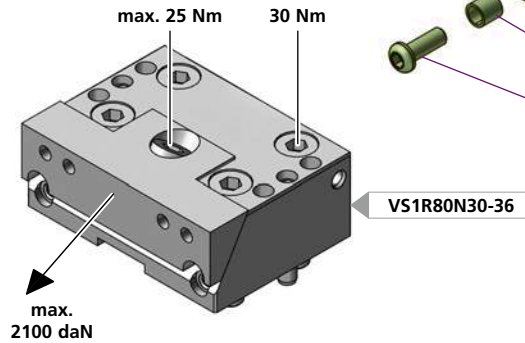
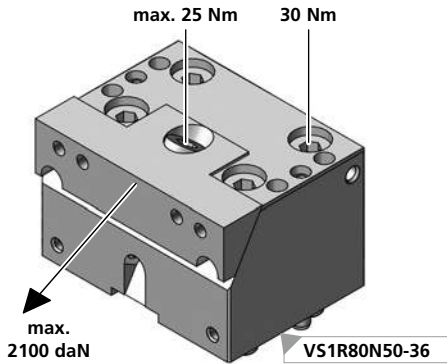
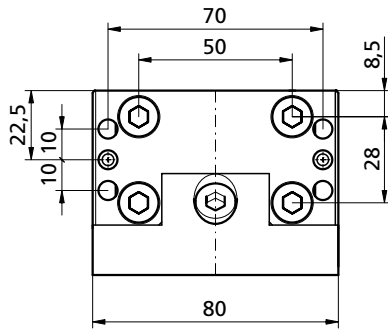
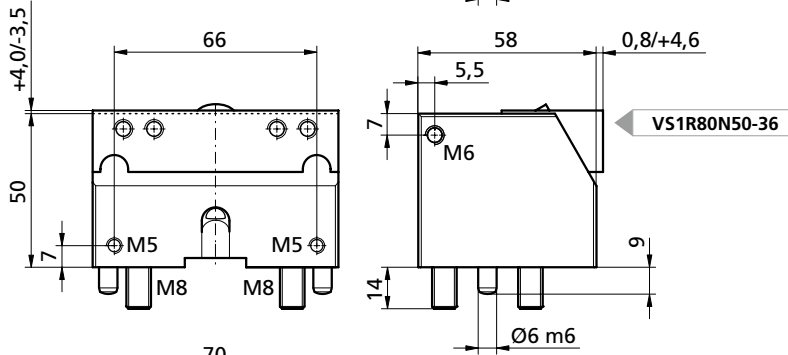
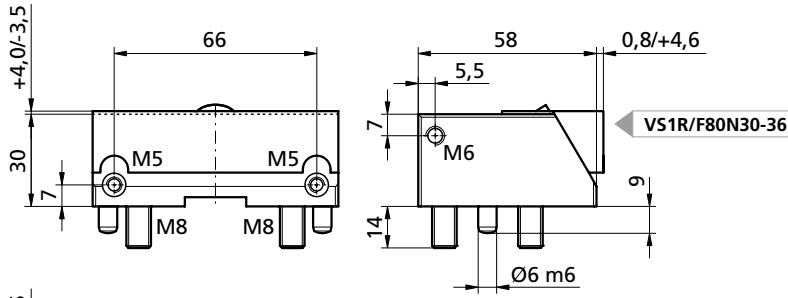

| | | |
|---------------------|---------------------|---------------------|
| VS1F80N30-36 | VS1R80N30-36 | VS1R80N50-36 |
| 1x TF140733 | 1x TF140734 | 1x TF140742 |
| 1x M8X20ISO4762 | 1x M8X35ISO4762 | 2x CCBO0803 |
| 4x FED0618 | 2x M5X8ISO4762 | 4x M8X55ISO4762 |
| 2x CCBO0801 | 2x CCD007 | 2x M5X12ISO7380 |
| 4x M8X35ISO4762 | 2x M5X16ISO7380 | |
| kg ~1,2 | kg ~1,9 | |

Bestellbeispiel / Ordering example: 1x VS1R80N30-36 & 1x B37

| | B36 | B37 | B38 |
|-----------|-----------------|-----------------|-------|
| C | 80 | 80 | 80 |
| H | 20 | 20 | 20 |
| L | 19 | 19 | 19 |
| D | 9 | 9 | 9 |
| ø | 12 | 12 | 12 |
| i | HV700 x0,2mm | HV700 x0,2mm | * |
| kg | ~0,18 | ~0,18 | ~0,18 |

B36, B37, B38

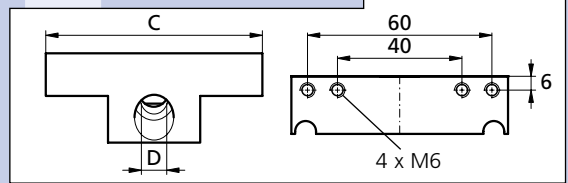
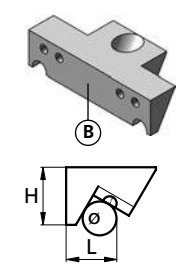

Separat bestellen / Order separately

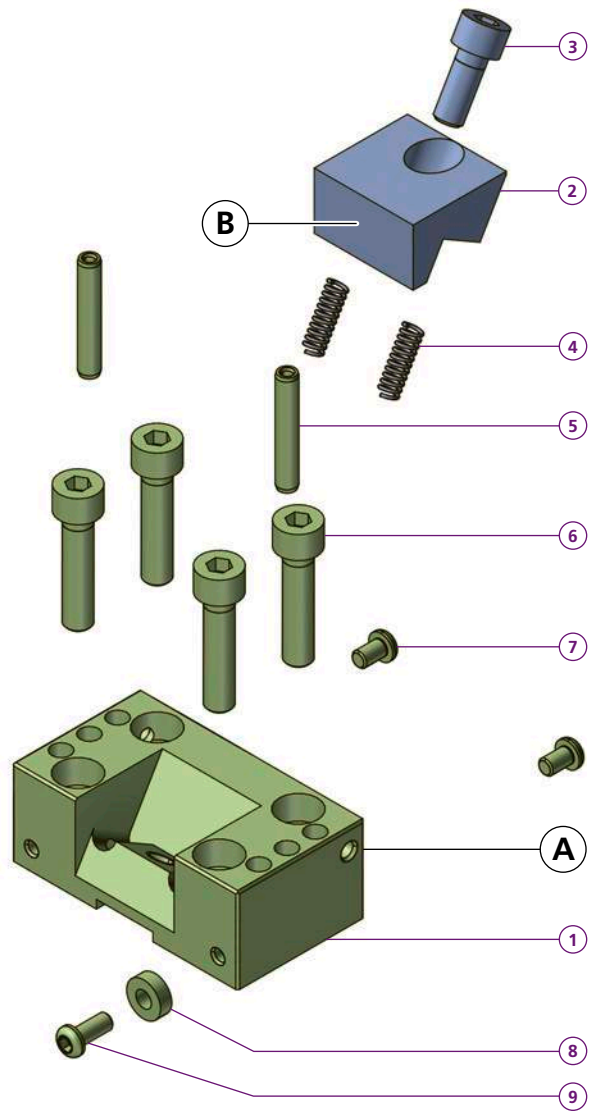
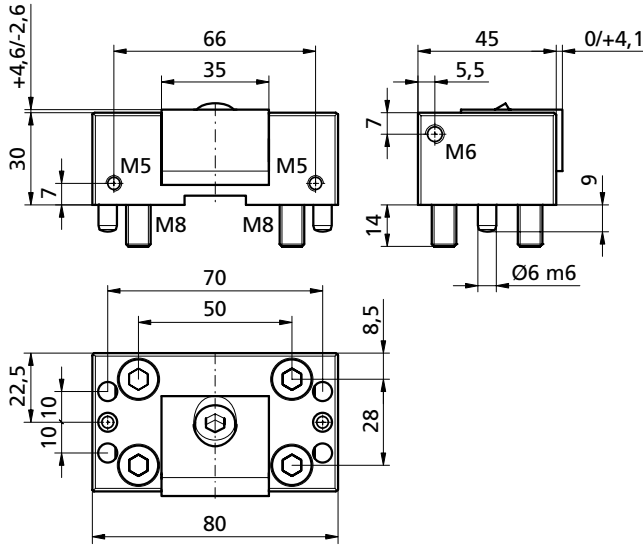

- VS1F80N30-60**
- 1 1x TF140735
- VS1R80N30-60**
- 1 1x TF140736
 - 2 1x
 - 3 1x M8X20ISO4762
 - 4 2x FED0618
 - 5 2x CCBO0801
 - 6 4x M8X35ISO4762
 - 7 2x M5X8ISO7380
 - 8 2x CCD004
 - 9 2x M5X12ISO7380
- kg ~0,74

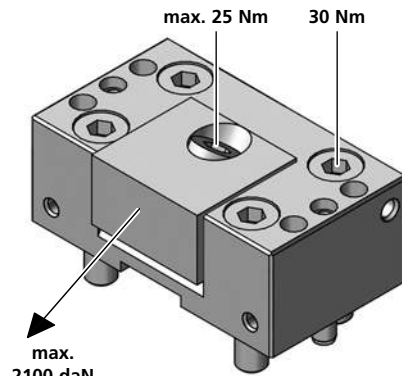

Bestellbeispiel / Ordering example: 1x VS1F80N30-60 & 1x B61

| | B58 | B60 | B61 | B62 | B62HM | B65 | B66 | B67 | B68 | B77 | B79F | B79R |
|----|-------|-------|-------|-------|-------|-----------------|-----------------|-----------------|-------|-------|-----------------|-----------------|
| C | 35 | 35 | 35 | 35 | 35 | 35 | 35 | 35 | 35 | 35 | 35 | 35 |
| H | 20 | 20 | 20 | 20 | 20 | 20 | 20 | 20 | 20 | 20 | 20 | 20 |
| L | 26 | 19 | 19 | 19 | 19 | 19 | 19 | 24 | 26 | 22 | 25 | 25 |
| D | 9 | 9 | 9 | 9 | 9 | 9 | 9 | 9 | 9 | 9 | 9 | 9 |
| ø | 12 | 12 | 12 | 12 | 12 | 12 | 12 | 12 | 12 | 12 | 12 | 12 |
| i | ALU | 56HRC | 56HRC | * | HM | HV700 x0,2mm | HV700 x0,2mm | HV700 x0,2mm | * | 56HRC | HV700 x0,2mm | HV700 x0,2mm |
| kg | ~0,07 | ~0,12 | ~0,12 | ~0,12 | ~0,12 | ~0,12 | ~0,12 | ~0,14 | ~0,15 | ~0,12 | ~0,18 | ~0,18 |

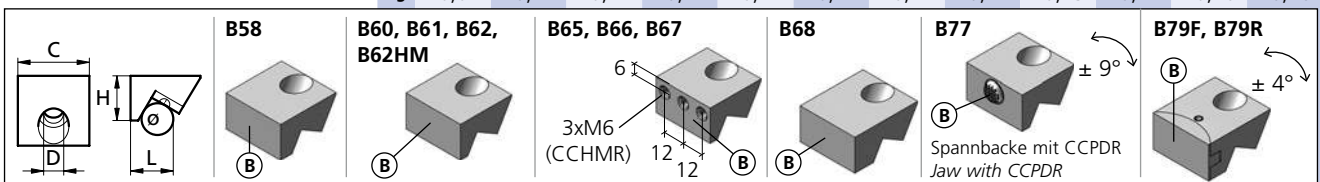

* = weicher Stahl / soft steel

HM = Hartmetallbeschichtet / Carbide coated

ALU = ENAW-7022

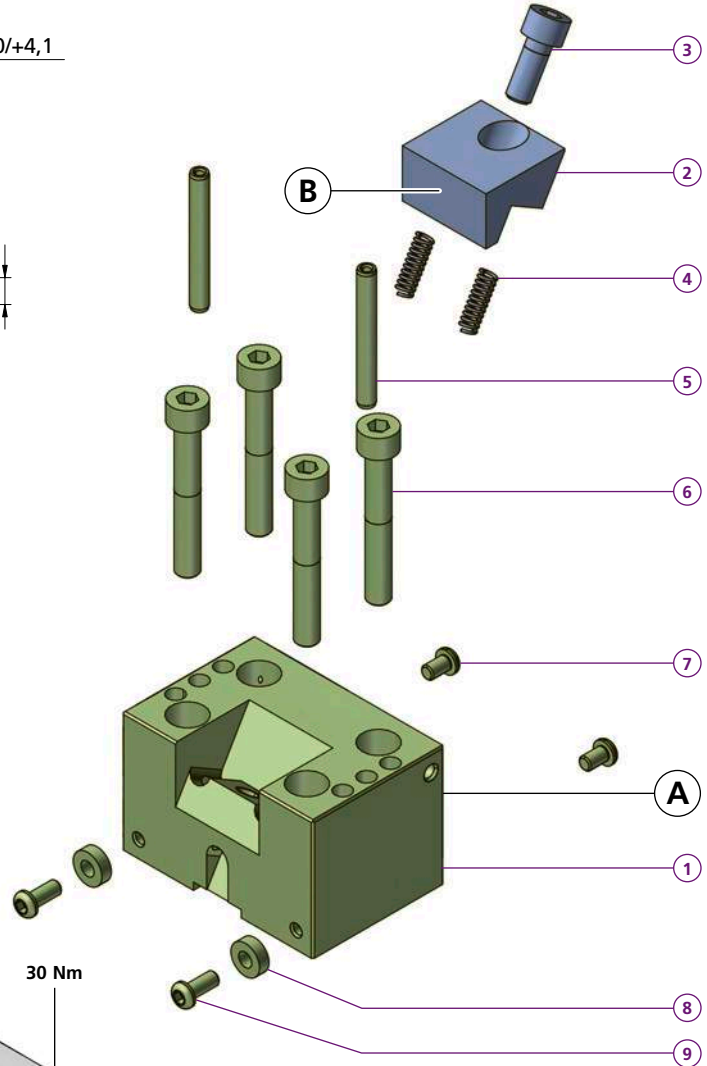
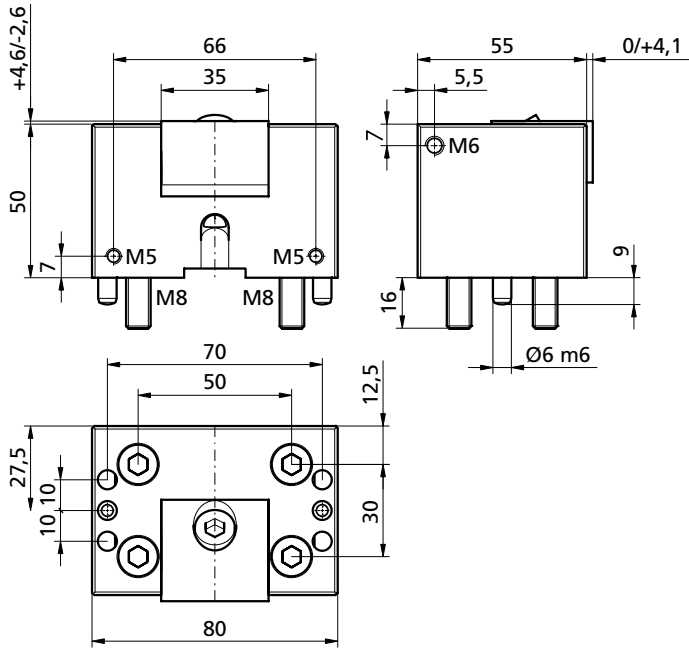

| VS1R80N50-60 | |
|--------------|-----------------|
| 1 | 1x TF140737 |
| 2 | 1x |
| 3 | 1x M8X20ISO4762 |
| 4 | 2x FED0618 |
| 5 | 2x CCBO0803 |
| 6 | 4x M8X55ISO4762 |
| 7 | 2x M5X8ISO7380 |
| 8 | 2x CCD004 |
| 9 | 2x M5X12ISO7380 |
| kg | ~1,6 |

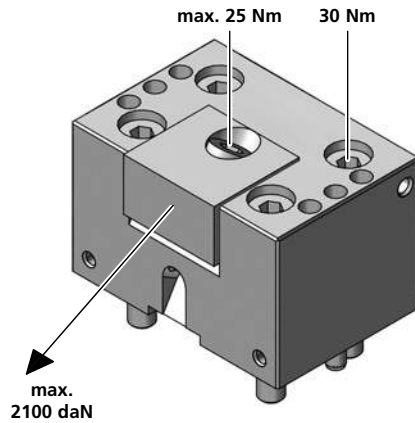

Bestellbeispiel / Ordering example: 1xVS1R80N50-60 & 1x B61

| | B58 | B60 | B61 | B62 | B62HM | B65 | B66 | B67 | B68 | B69 | B77 | B79F | B79R |
|----|-------|-------|-------|-------|-------|-----------------|-----------------|-----------------|-------|-------|-------|-----------------|-----------------|
| C | 35 | 35 | 35 | 35 | 35 | 35 | 35 | 35 | 35 | 35 | 35 | 35 | 35 |
| H | 20 | 20 | 20 | 20 | 20 | 20 | 20 | 20 | 20 | 25 | 20 | 20 | 20 |
| L | 26 | 19 | 19 | 19 | 19 | 19 | 19 | 24 | 26 | 22 | 22 | 25 | 25 |
| D | 9 | 9 | 9 | 9 | 9 | 9 | 9 | 9 | 9 | 9 | 9 | 9 | 9 |
| ø | 12 | 12 | 12 | 12 | 12 | 12 | 12 | 12 | 12 | 12 | 12 | 12 | 12 |
| i | ALU | 56HRC | 56HRC | * | HM | HV700 x0,2mm | HV700 x0,2mm | HV700 x0,2mm | * | * | 56HRC | HV700 x0,2mm | HV700 x0,2mm |
| kg | ~0,07 | ~0,12 | ~0,12 | ~0,12 | ~0,12 | ~0,12 | ~0,12 | ~0,14 | ~0,15 | ~0,15 | ~0,12 | ~0,18 | ~0,18 |

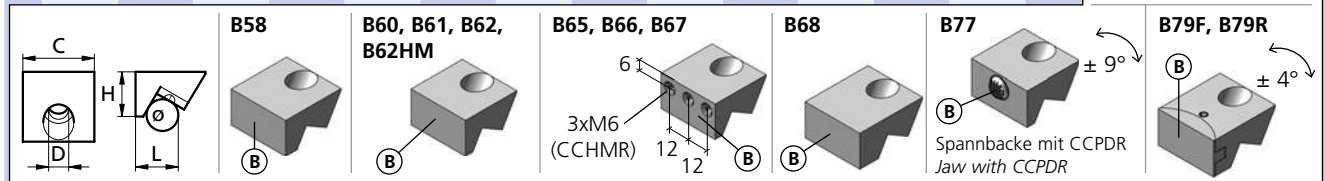
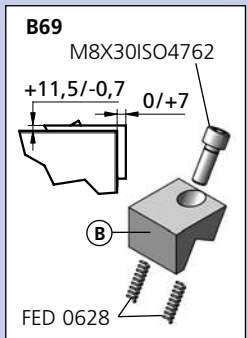

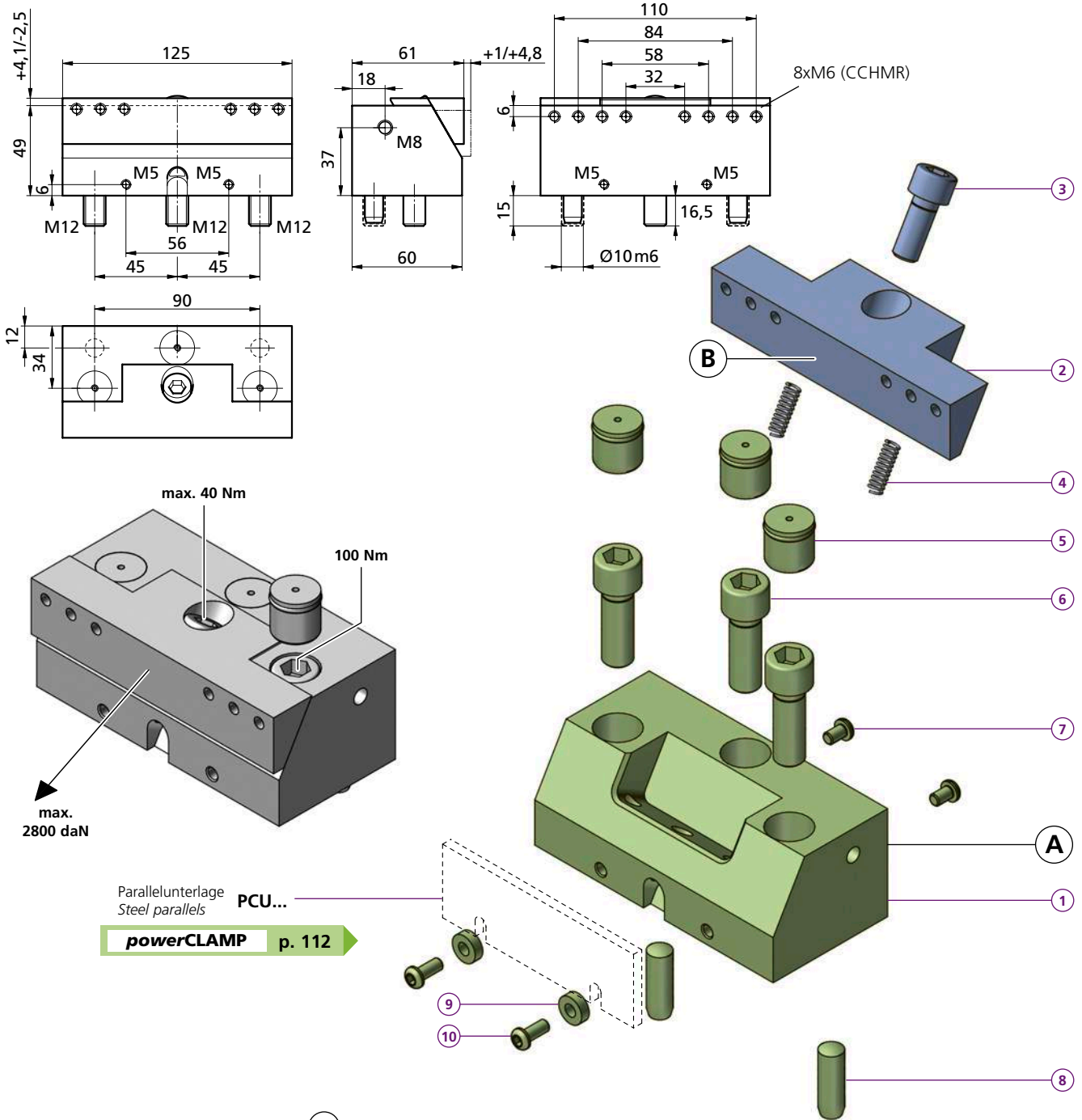

Bestellbeispiel / Ordering example: 1x VS1R125N49-95 & 1x B96

| | B95 | B96 | B97 | B98 | B99 |
|----------------------|------|-----|-----|-----|-----|
| VS1F125N49-95 | | | | | |
| ① 1x TF140738 | | | | | |
| VS1R125N49-95 | | | | | |
| ① 1x TF140739 | | | | | |
| ② 1x | | | | | |
| ③ 1x M10X25ISO4762 | | | | | |
| ④ 2x FED0618 | | | | | |
| ⑤ 3x PCPF16L18Alu | | | | | |
| ⑥ 3x M12X35ISO4762 | | | | | |
| ⑦ 3x M5X8ISO7380 | | | | | |
| ⑧ 2x 10m6x30 DIN6325 | | | | | |
| ⑨ 2x CCD004 | | | | | |
| ⑩ 2x M5X12ISO7380 | | | | | |
| kg | ~2,6 | | | | |

| | B95 | B96 | B97 | B98 | B99 |
|-----|--------|--------|-------|-------|--------|
| ⓐ C | 125 | 125 | 125 | 125 | 125 |
| ⓐ H | 25 | 25 | 25 | 25 | 25 |
| ⓐ L | 23 | 23 | 23 | 30 | 23 |
| ⓐ D | 11 | 11 | 11 | 11 | 11 |
| ⓐ e | 15 | 15 | 15 | 15 | 15 |
| ⓐ i | HV700 | HV700 | * | * | HV700 |
| | x0,2mm | x0,2mm | | | x0,2mm |
| kg | ~0,45 | ~0,45 | ~0,45 | ~0,63 | ~0,45 |

| | B95, B96, B97, B99 | B98 |
|----|--------------------|-----|
| ② | | |
| ③ | | |
| ④ | | |
| ⑤ | | |
| ⑥ | | |
| ⑦ | | |
| ⑧ | | |
| ⑨ | | |
| ⑩ | | |
| kg | | |

* = weicher Stahl / soft steel

Separat bestellen / Order separately

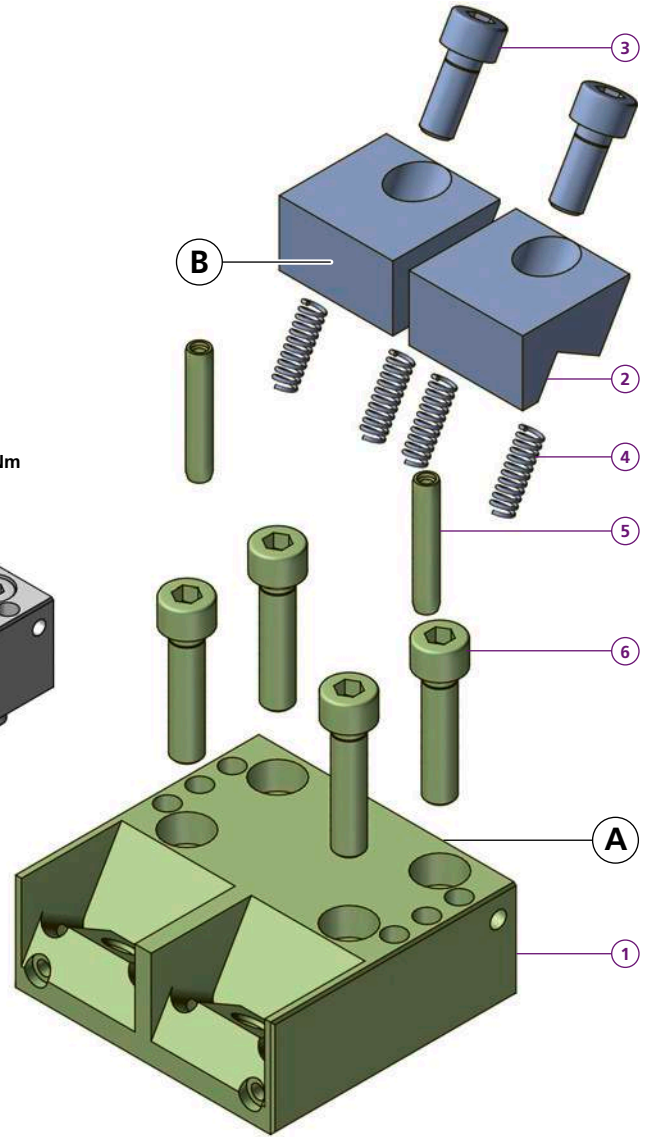
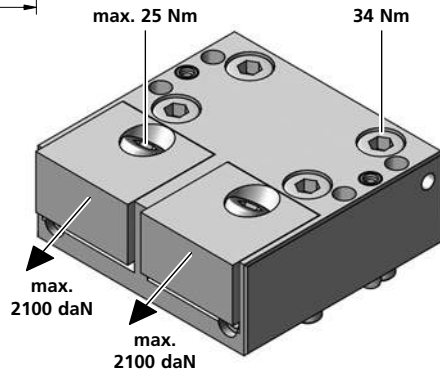
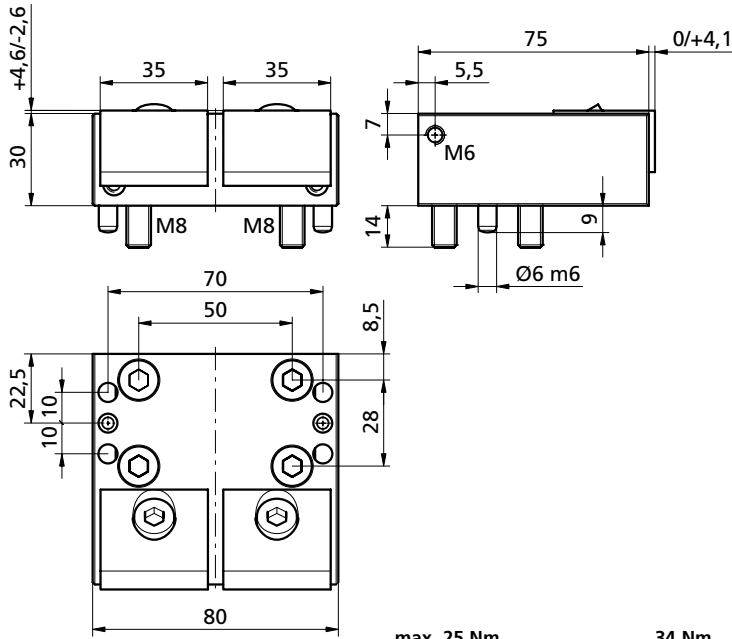

| VS2R80N30-60 | |
|--------------|-----------------|
| 1 | 1x TF140740 |
| 2 | 2x |
| 3 | 2x M8X20ISO4762 |
| 4 | 4x FED0618 |
| 5 | 2x CCBO0801 |
| 6 | 4x M8X35ISO4762 |
| kg | ~1,3 |

Bestellbeispiel / Ordering example: 1x VS2R80N30-60 & 2x B61

| | B58 | B60 | B61 | B62 | B62HM | B65 | B66 | B67 | B68 | B77 | B79F | B79R |
|----|-------|--------|--------|-------|-------|--------|--------|--------|-------|-------|--------|--------|
| C | 35 | 35 | 35 | 35 | 35 | 35 | 35 | 35 | 35 | 35 | 35 | 35 |
| H | 20 | 20 | 20 | 20 | 20 | 20 | 20 | 20 | 20 | 20 | 20 | 20 |
| L | 26 | 19 | 19 | 19 | 19 | 19 | 19 | 24 | 26 | 22 | 25 | 25 |
| D | 9 | 9 | 9 | 9 | 9 | 9 | 9 | 9 | 9 | 9 | 9 | 9 |
| ø | 12 | 12 | 12 | 12 | 12 | 12 | 12 | 12 | 12 | 12 | 12 | 12 |
| i | ALU | 56HRC | 56HRC | * | HM | HV700 | HV700 | HV700 | * | 56HRC | HV700 | HV700 |
| | | x0,2mm | x0,2mm | | | x0,2mm | x0,2mm | x0,2mm | | | x0,2mm | x0,2mm |
| kg | ~0,07 | ~0,12 | ~0,12 | ~0,12 | ~0,12 | ~0,12 | ~0,12 | ~0,14 | ~0,15 | ~0,12 | ~0,18 | ~0,18 |

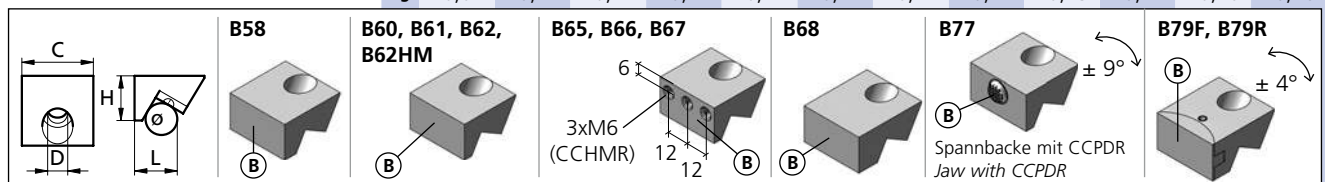

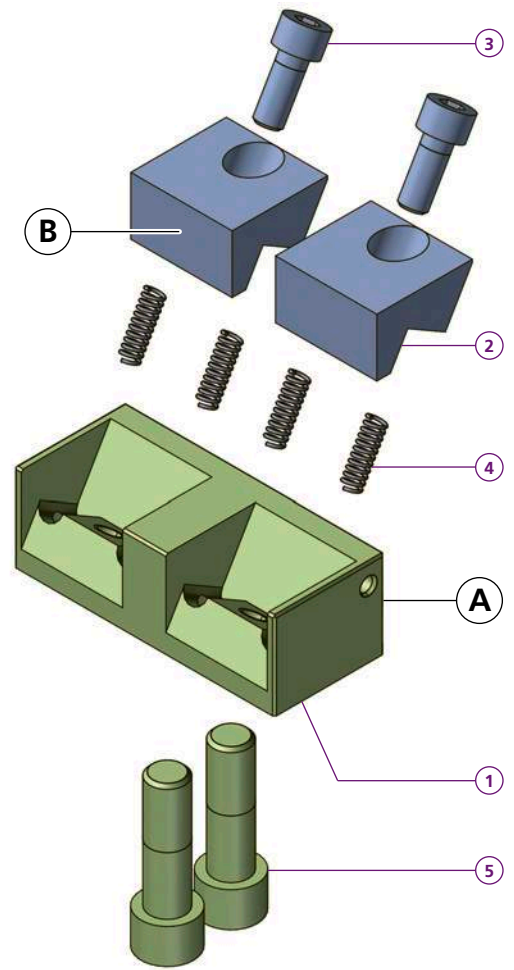
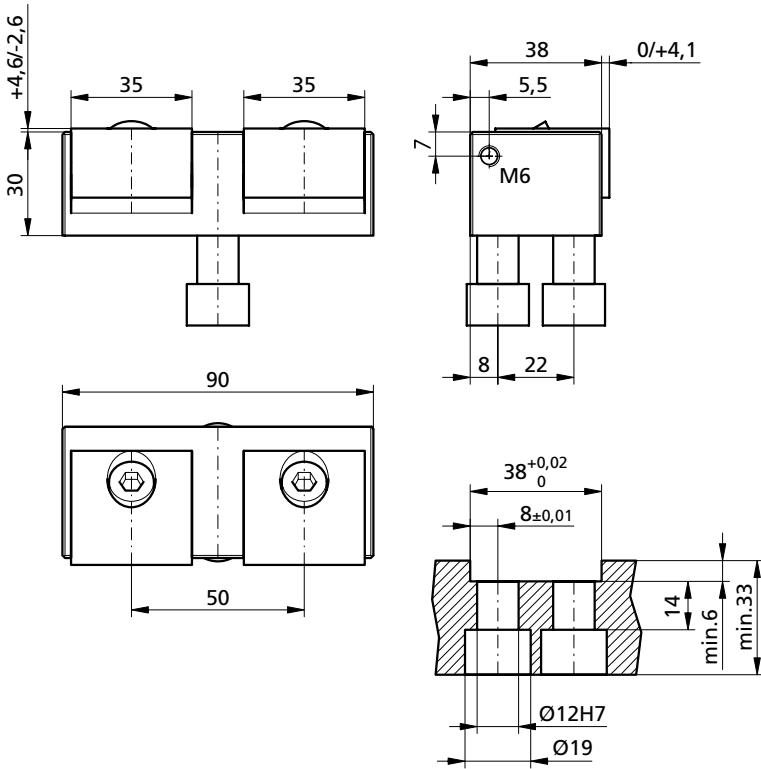

| VS2F90N30-60 | |
|--------------|-----------------|
| 1 | 1x TF140741 |
| 2 | 2x |
| 3 | 2x M8X20ISO4762 |
| 4 | 4x FED0618 |
| 5 | 2x TWPAS1232 |
| kg | ~0,85 |

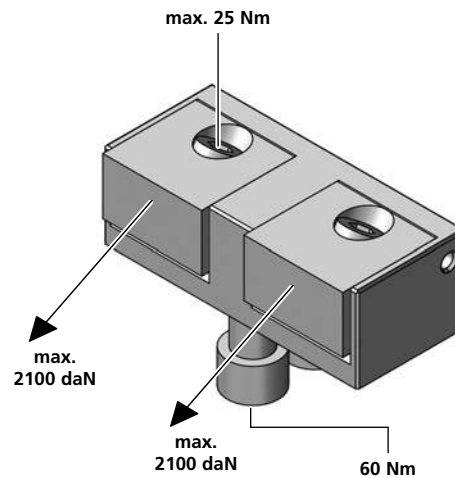

Bestellbeispiel / Ordering example: 1x VS2F90N30-60 & 2x B61

| | B58 | B60 | B61 | B62 | B62HM | B65 | B66 | B67 | B68 | B77 | B79F | B79R |
|----|-------|--------|--------|-------|-------|--------|--------|--------|-------|-------|--------|--------|
| C | 35 | 35 | 35 | 35 | 35 | 35 | 35 | 35 | 35 | 35 | 35 | 35 |
| H | 20 | 20 | 20 | 20 | 20 | 20 | 20 | 20 | 20 | 20 | 20 | 20 |
| L | 26 | 19 | 19 | 19 | 19 | 19 | 19 | 24 | 26 | 22 | 25 | 25 |
| D | 9 | 9 | 9 | 9 | 9 | 9 | 9 | 9 | 9 | 9 | 9 | 9 |
| ø | 12 | 12 | 12 | 12 | 12 | 12 | 12 | 12 | 12 | 12 | 12 | 12 |
| i | ALU | 56HRC | 56HRC | * | HM | HV700 | HV700 | HV700 | * | 56HRC | HV700 | HV700 |
| | | x0,2mm | x0,2mm | | | x0,2mm | x0,2mm | x0,2mm | | | x0,2mm | x0,2mm |
| kg | ~0,07 | ~0,12 | ~0,12 | ~0,12 | ~0,12 | ~0,12 | ~0,12 | ~0,14 | ~0,15 | ~0,12 | ~0,18 | ~0,18 |

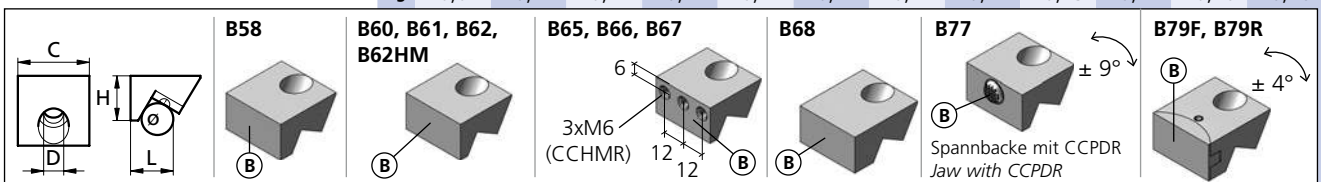

* = weicher Stahl / soft steel

HM = Hartmetallbeschichtet / Carbide coated

ALU = ENAW-7022

MS1R/F35L14-152

MS1R/F35L14-150 (Alte Version / Old Version)

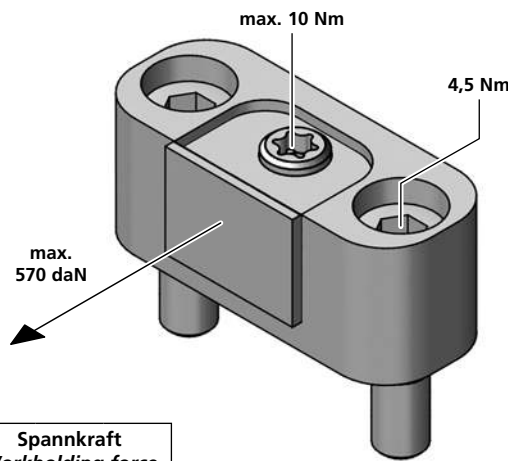
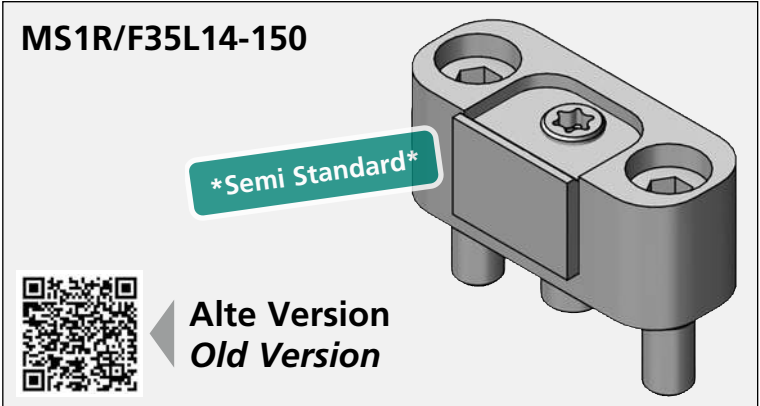
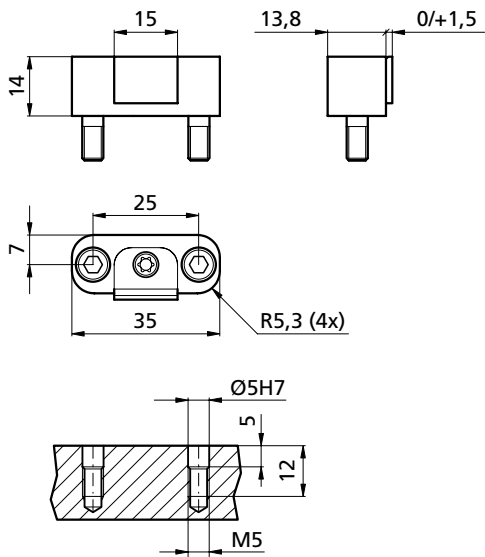

| Drehmoment Torque | | Spannkraft Workholding force | | |
|----------------------|---------|---------------------------------|-------|------|
| Nm | (lb-ft) | ~daN | ~(lb) | ~t |
| 7 | 5,18 | = 390 | 860 | 0,39 |
| 8 | 5,92 | = 450 | 990 | 0,45 |
| 9 | 6,66 | = 510 | 1120 | 0,51 |
| 10 | 7,4 | = 570 | 1250 | 0,57 |

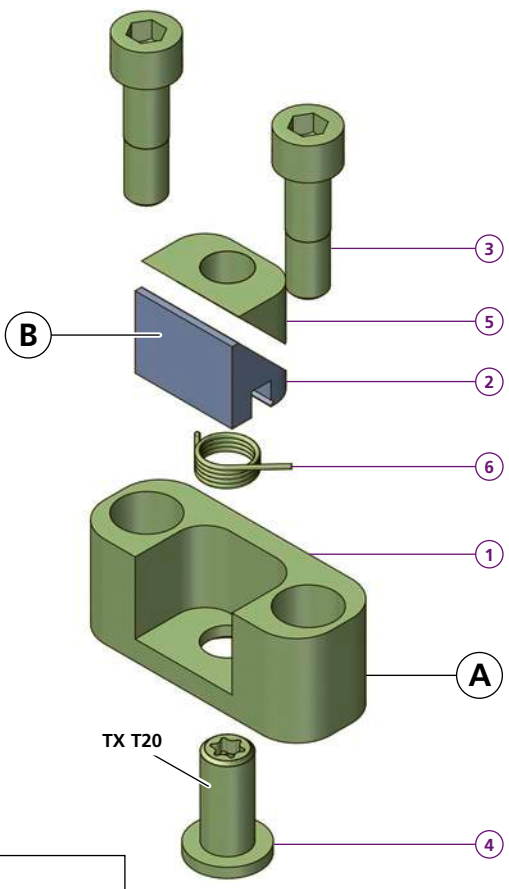

Achtung: Bei Spannkraften über 400 daN (0,4t) muss das Spannmodul in eine Nut eingelassen werden (Nuttiefe mindestens 1mm)

Remark: Using forces higher than 400 daN, clamps must be mounted into a slot (depth minimum 1mm)

Vorrichtungsplatte / Fixture plate

- MS1F35L14-152**
- 1x TK181266
- MS1R35L14-152**
- 1x TF190596
- 1x _____
- 2x MS50
- 1x GEWST6L14
- 1x MSK15W45
- 1x SFED6W90
- kg ~0,03

Bestellbeispiel / Ordering example: 1x MS1F35L14-152 & 1x B151

| | B150 | B151 |
|----|--------|--------|
| C | 15 | 15 |
| H | 11 | 11 |
| L | 40,3 | 40,3 |
| ø | 40 | 40 |
| i | HV700 | HV700 |
| | x0,2mm | x0,2mm |
| kg | ~0,004 | ~0,004 |

Separat bestellen / Order separately

VS1R26L35-31

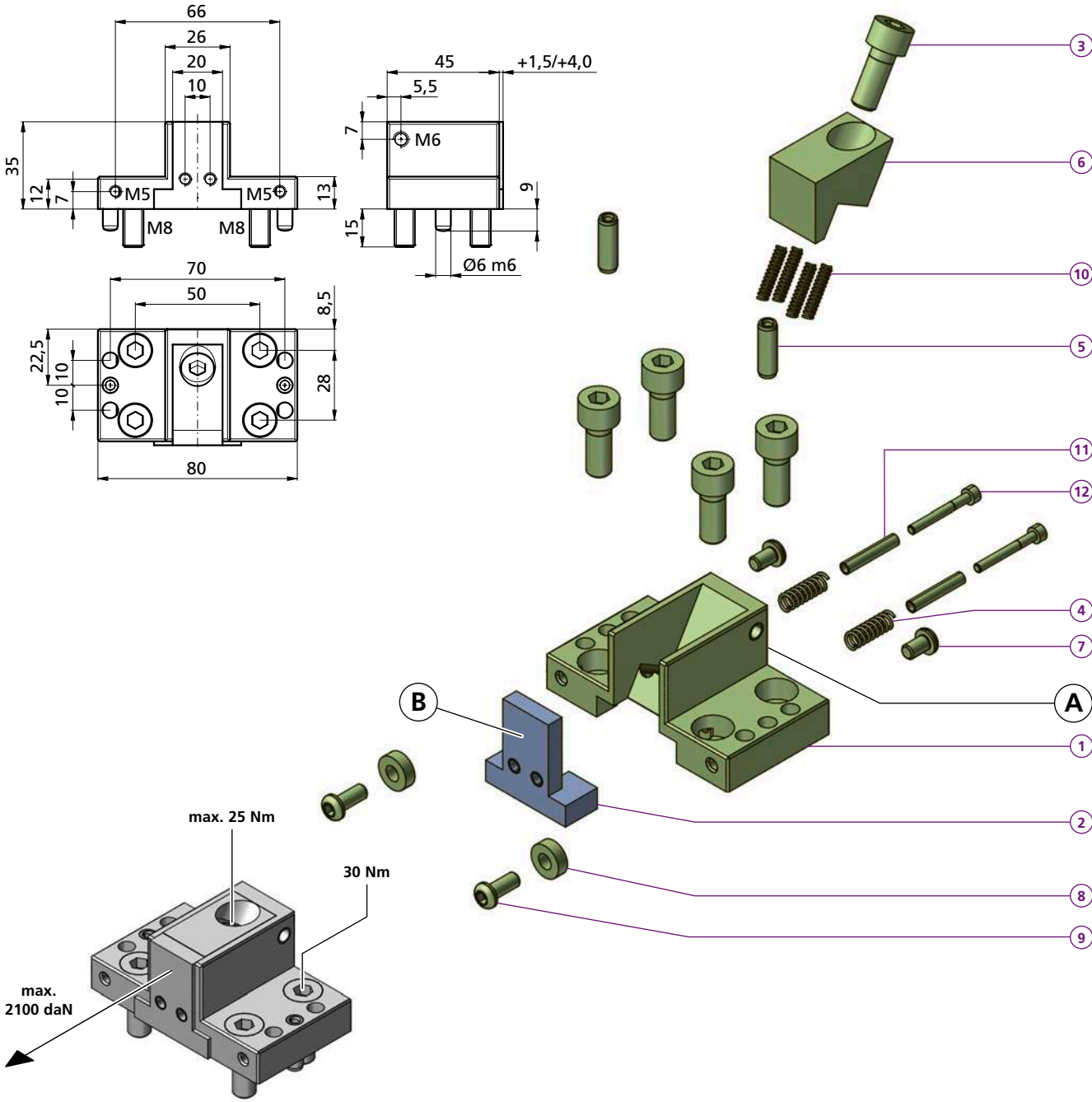

| VS1R26L35-31 | |
|--------------|-----------------|
| 1 | 1x TF140724 |
| 2 | 1x |
| 3 | 5x M8X20ISO4762 |
| 4 | 2x FED0618 |
| 5 | 2x CCBO0802 |
| 6 | 1x B30 |
| 7 | 2x M5X8ISO7380 |
| 8 | 2x CCD004 |
| 9 | 2x M5X12ISO7380 |
| 10 | 4x FED0418 |
| 11 | 2x CCD422 |
| 12 | 2x M3X25ISO4762 |
| kg | ~0,55 |

Bestellbeispiel / Ordering example: 1x VS1R26L35-31 & 1x B32

| | B31 | B32 | B33 |
|----|-----------------|-----------------|--------|
| C | 20 | 20 | 20 |
| H | 35 | 35 | 35 |
| L | 6 | 6 | 6 |
| D | - | - | - |
| e | - | - | - |
| i | HV700 x0,2mm | HV700 x0,2mm | * |
| kg | ~0,046 | ~0,046 | ~0,046 |

B31, B32, B33

* = weicher Stahl / soft steel

Separat bestellen / Order separately

VS1R/F41L30-51

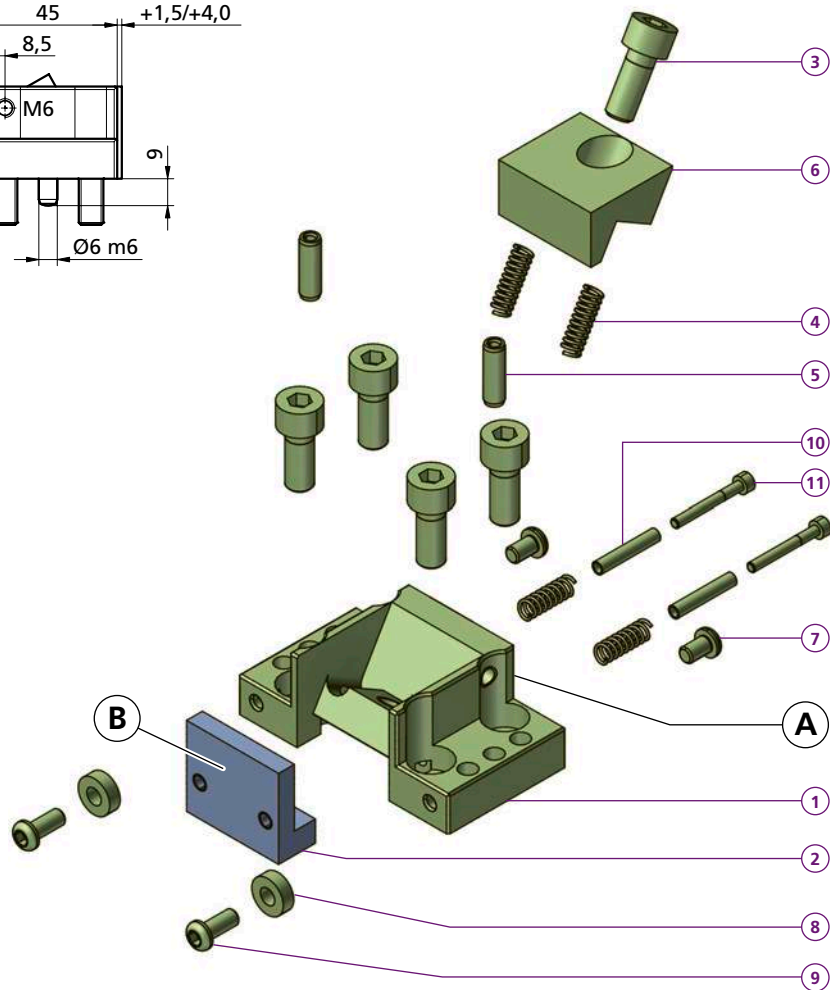
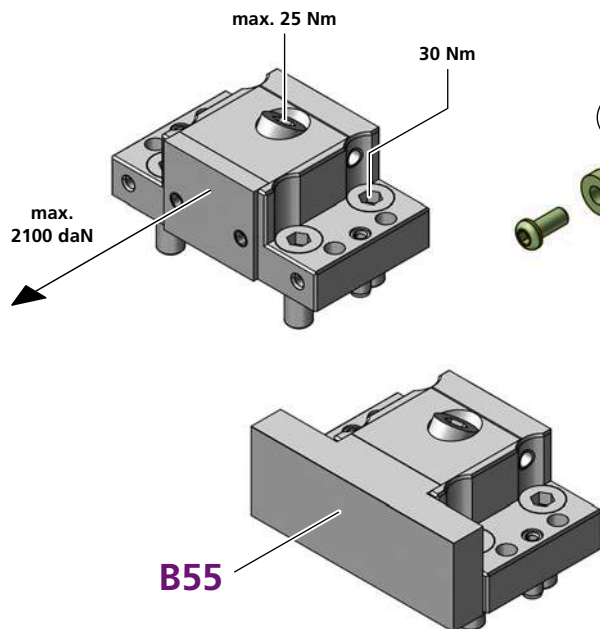
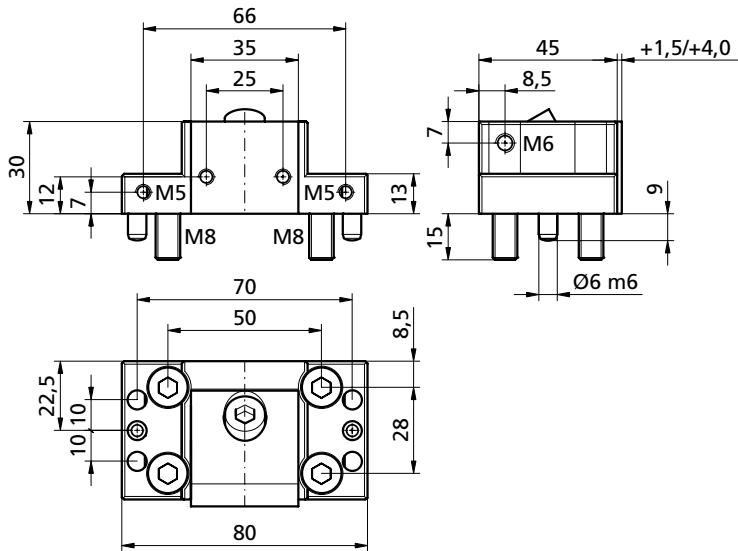

| | |
|---------------------|--|
| VS1F41L30-51 | |
| 1x TF140727 | |
| VS1R41L30-51 | |
| 1x TF140728 | |
| 1x | |
| 5x M8X20ISO4762 | |
| 4x FED0618 | |
| 2x CCBO0802 | |
| 1x B78 | |
| 2x M5X8ISO7380 | |
| 2x CCD004 | |
| 2x M5X12ISO7380 | |
| 2x CCD422 | |
| 2x M3X25ISO4762 | |
| kg ~0,545 | |

B Bestellbeispiel / Ordering example: 1x VS1R41L30-51 & 1x B52

| | B51 | B52 | B53 | B54 | B55 |
|-----------|-----------------|-----------------|-------|-------|-------|
| C | 35 | 35 | 35 | 35 | 80 |
| H | 30 | 30 | 30 | 35 | 30 |
| L | 6 | 6 | 10 | 10 | 11,5 |
| D | - | - | - | - | - |
| e | - | - | - | - | - |
| i | HV700 x0,2mm | HV700 x0,2mm | * | * | * |
| kg | ~0,06 | ~0,06 | ~0,06 | ~0,12 | ~0,27 |

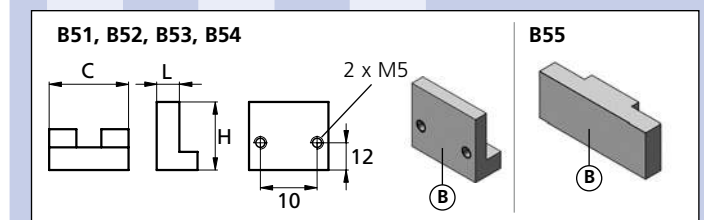

Separat bestellen / Order separately

Vorrichtungsbau-Modul für Linearbacken

Alle bestehenden Linearbacken passen auf dieses Modul
(**powerCLAMP** Seite **84 - 85**). In die Vorrichtungsplatte wird eine Tasche gefräst um das Modul zu positionieren. Gut geeignet sind die Anschlagbacken **MAND** und **MANF** um als Gegenbacke zu dienen.

Fixture clamp module for linear jaws

All of our standard linear jaws fit to this clamp module
(**powerCLAMP** Page **84 - 85**). All to do is milling a pocket to fit and positioning the clamp modules. To use the **MAND** and **MANF** as datum stop will make a perfect match. (Seite / Page **175 - 176**)

Fertigungsmasse für die Vorrichtungsplatte
Machining data for the fixture plate

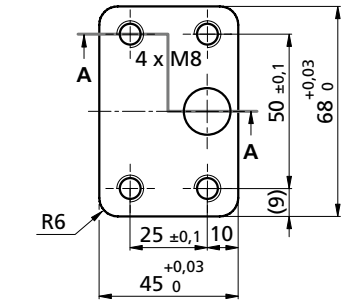

Schnitt / Section A-A

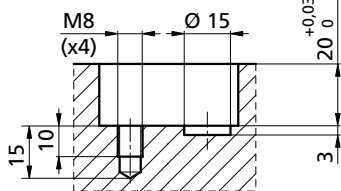

Das Fertigungsmass gilt auch für das Anschlagmodul.
The production dimension is also valid for the end module. (VA168-20PRG)

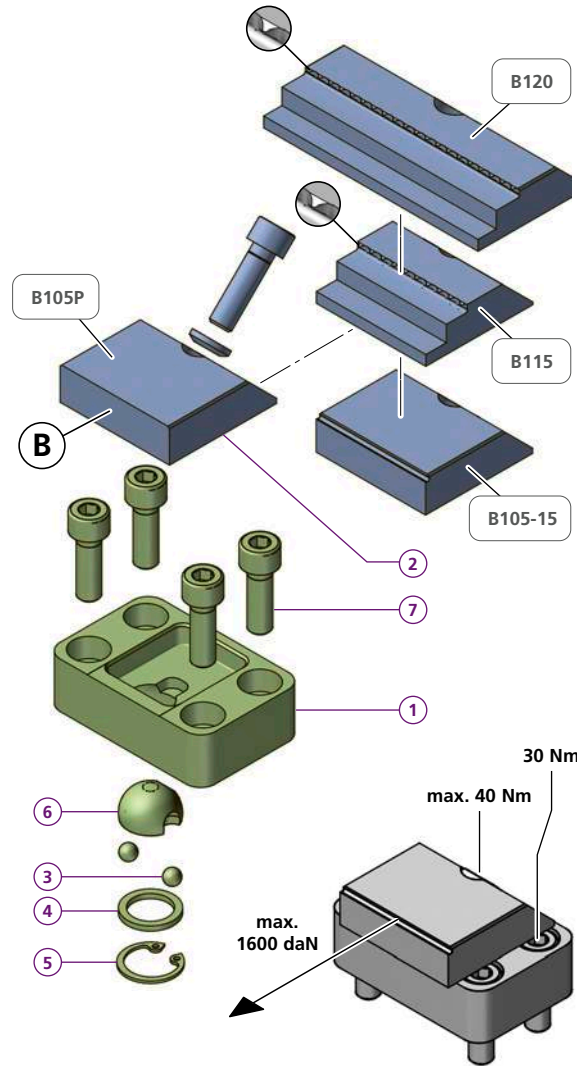
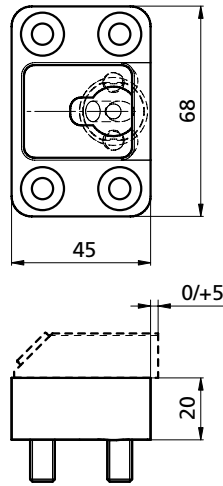

| VS1X68L20-105 | |
|---------------|--------------------------------|
| 1 | 1x TB150170 |
| 2 | 1x powerCLAMP p 84 - 85 |
| 3 | 1x BN869d=6 |
| 4 | 1x TN100747 |
| 5 | 1x TN100779 |
| 6 | 1x PCKMR45M8 |
| 7 | 4x M8X20ISO4762 |
| kg | ~0,42 |

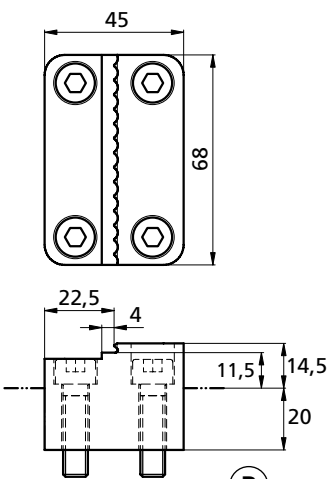

| VA168-20PRG | |
|-------------|-----------------|
| 8 | 1x TH160280 |
| 9 | 4x M8X30ISO4762 |
| kg | ~0,75 |

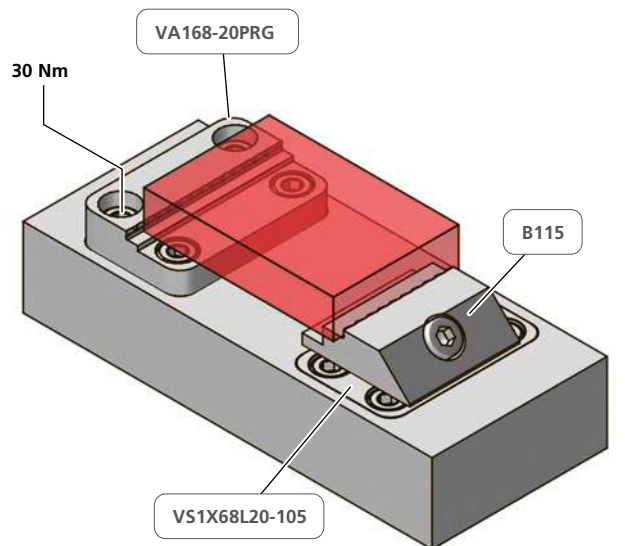
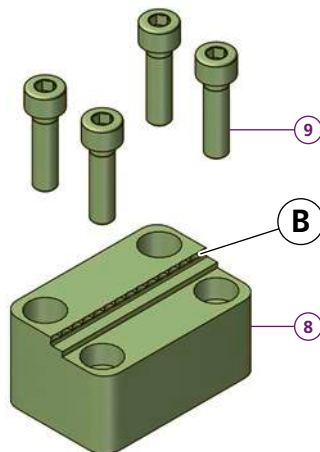

Bestellbeispiel / Ordering example: 1x VS1X68L20-105 & 1x B105P

Separat bestellen / Order separately

VS1F48L50-105

VS1P48L50-105

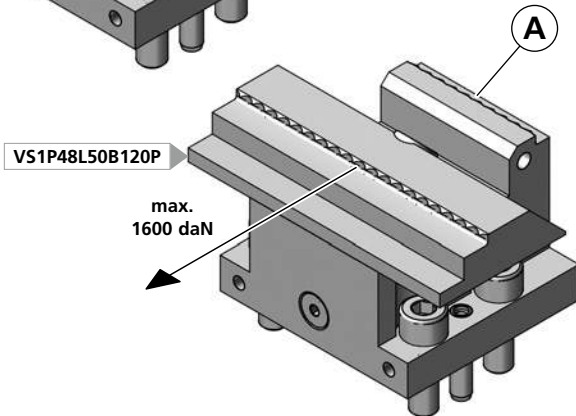
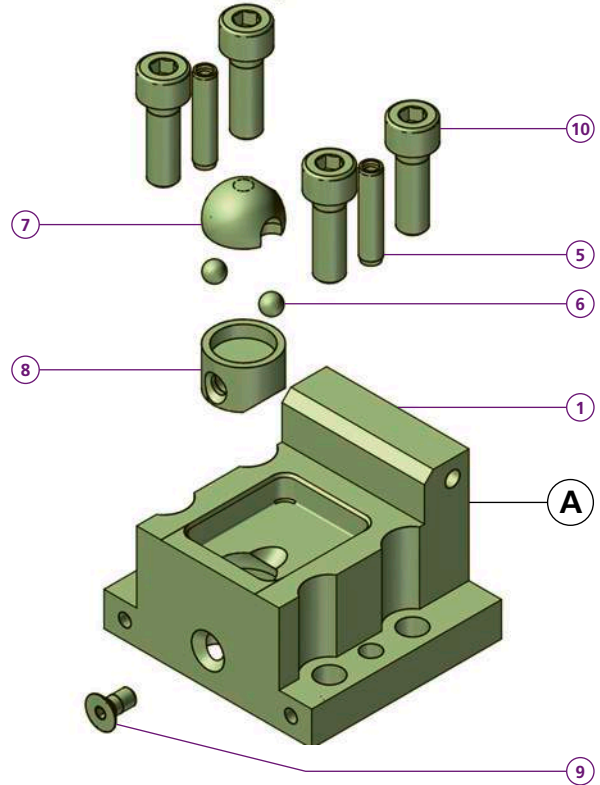
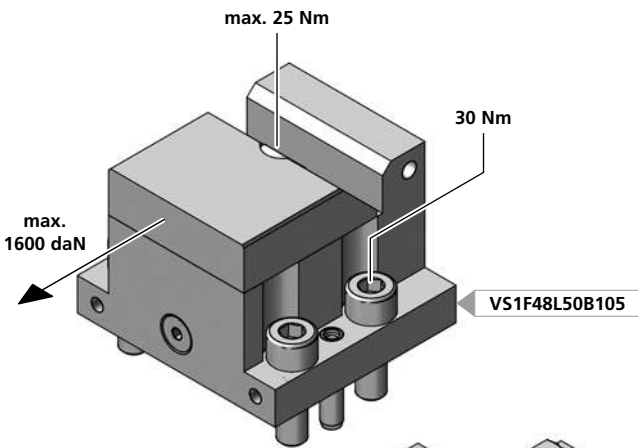
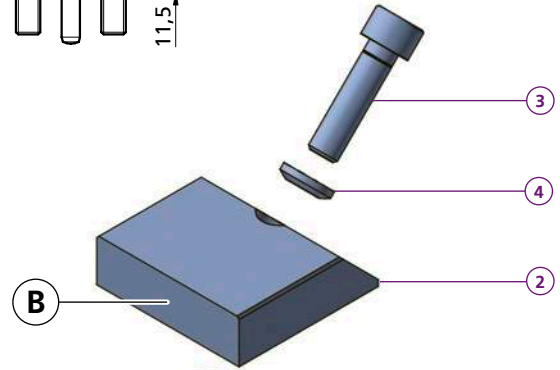
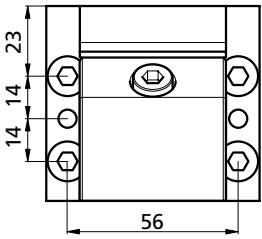
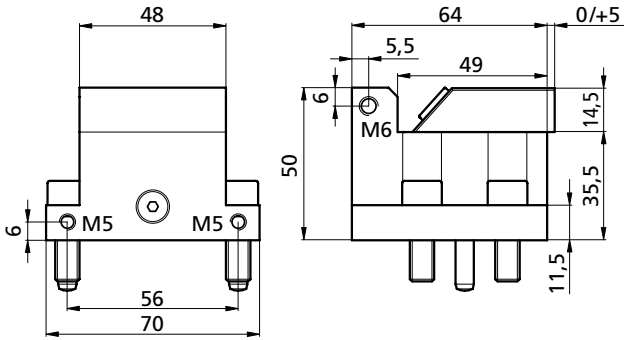

| | | |
|----|----------------------|--|
| | VS1F48L50-105 | |
| 1 | 1x TK120807 | |
| | VS1P48L50-105 | |
| 1 | 1x TK120761 | |
| 2 | 1x powerCLAMP | |
| 3 | 1x M8X30ISO4762 | |
| 4 | 1x PCUSR14 | |
| 5 | 1x 6-m6x26 DIN 79790 | |
| 6 | 2x BN869d=6 | |
| 7 | 1x PCKMR45M8 | |
| 8 | 2x TS120001-04 | |
| 9 | 1x M5X10DIN7991 | |
| 10 | 4x M8X25ISO4762 | |
| kg | ~1,21 | |

powerCLAMP p. 84 - 85

Bestellbeispiel / Ordering example: 1x VS1F48L50-105 & 1x B105

Separat bestellen / Order separately

VS1R/F80L30-51

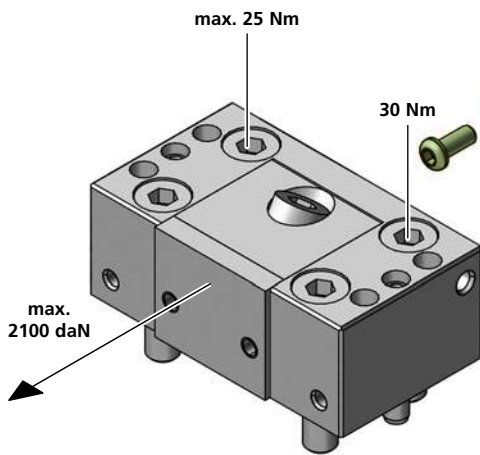
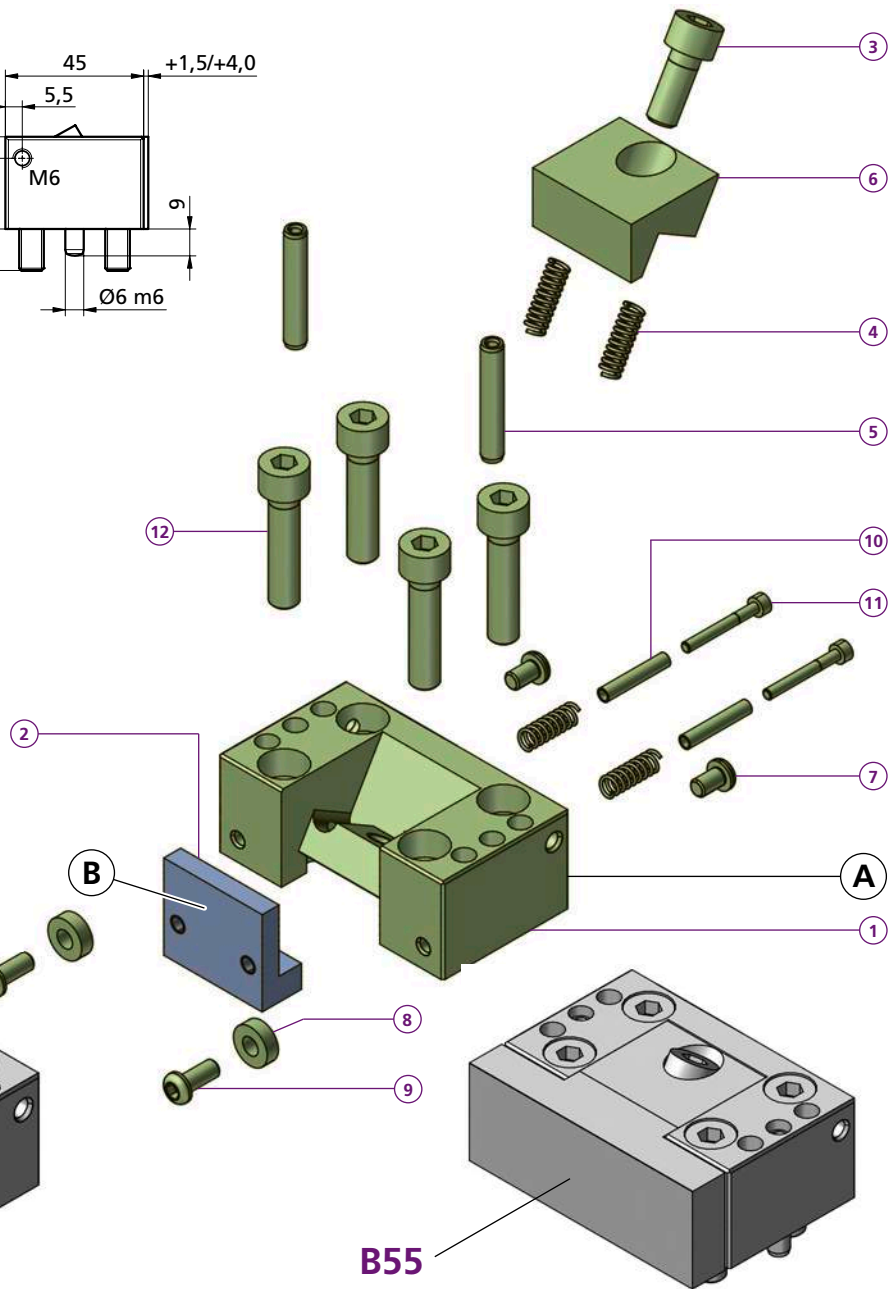
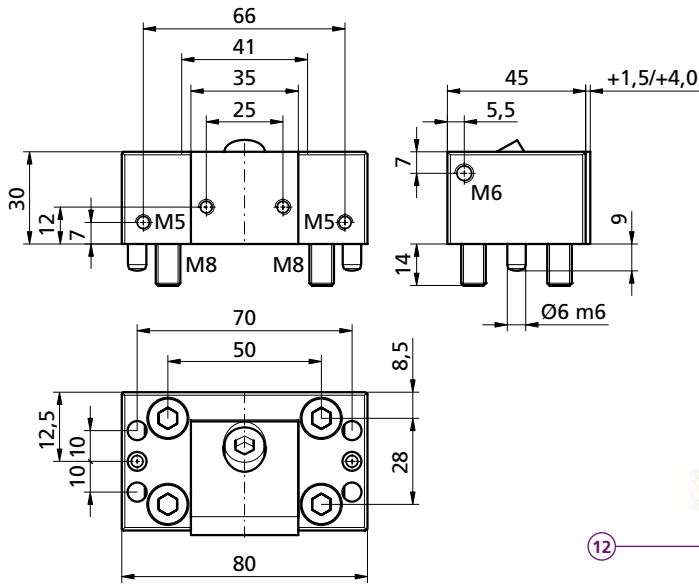

B55

B Bestellbeispiel / Ordering example: 1x VS1R80L30-51 & 1x B52

| VS1F80L30-51 | |
|--------------|-----------------|
| 1 | 1x TF140731 |
| VS1R80L30-51 | |
| 1 | 1x TF140732 |
| 2 | 1x |
| 3 | 1x M8X20ISO4762 |
| 4 | 4x FED0618 |
| 5 | 2x CCBO0801 |
| 6 | 1x B78 |
| 7 | 2x M5X8ISO7380 |
| 8 | 2x CCD004 |
| 9 | 2x M5X12ISO7380 |
| 10 | 2x CCD422 |
| 11 | 2x M3X25ISO4762 |
| 12 | 4x M8X35ISO4762 |
| kg | ~0,74 |

| | B51 | B52 | B53 | B54 | B55 |
|----|-----------------|-----------------|-------|-------|-------|
| C | 35 | 35 | 35 | 35 | 80 |
| H | 30 | 30 | 30 | 35 | 30 |
| L | 6 | 6 | 10 | 10 | 11,5 |
| D | - | - | - | - | - |
| e | - | - | - | - | - |
| i | HV700 x0,2mm | HV700 x0,2mm | * | * | * |
| kg | ~0,06 | ~0,06 | ~0,06 | ~0,12 | ~0,27 |

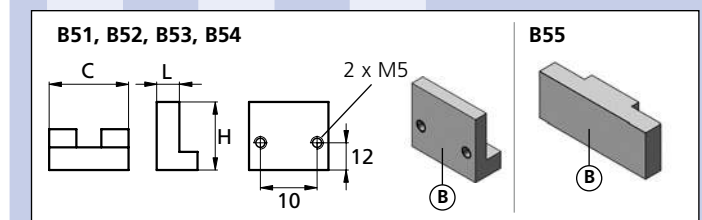

* = weicher Stahl / soft steel

VS1X59L60K

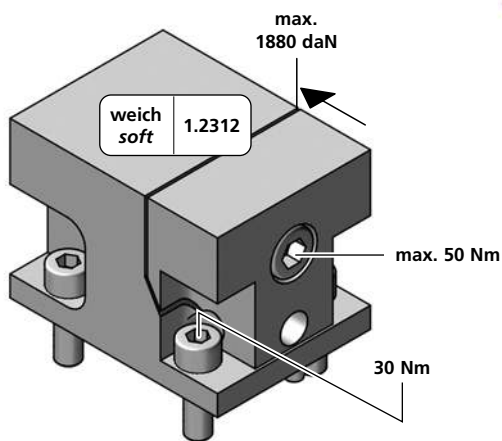
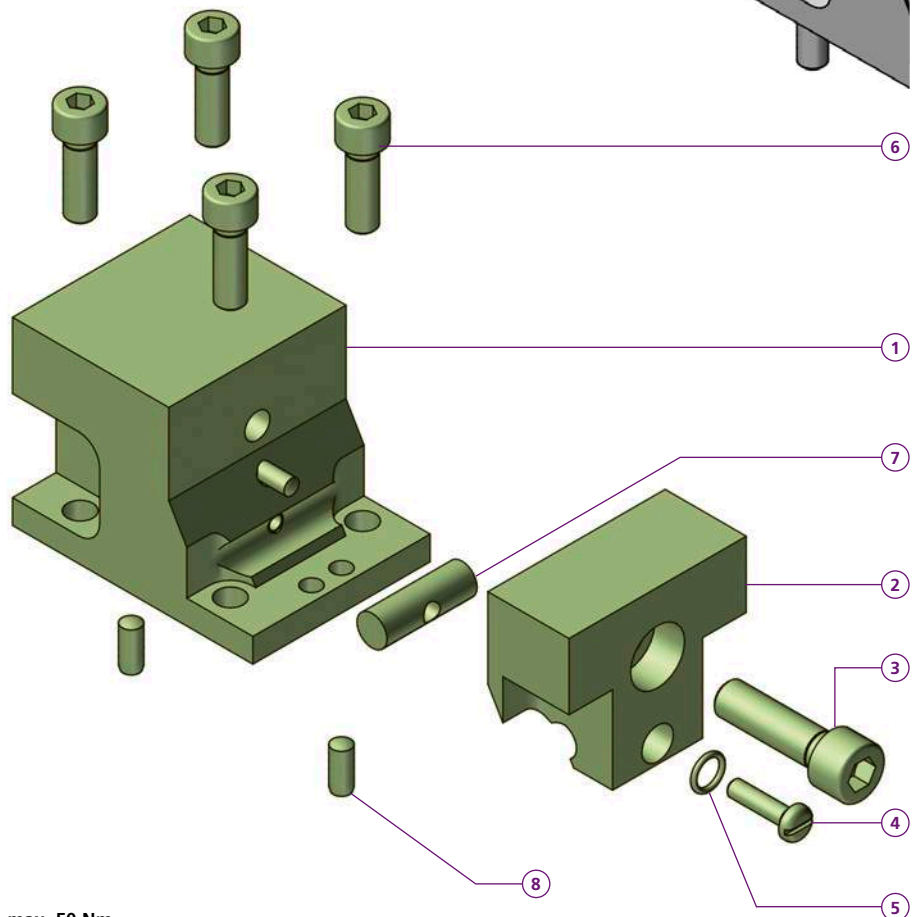
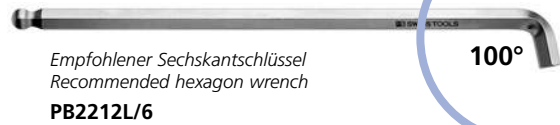
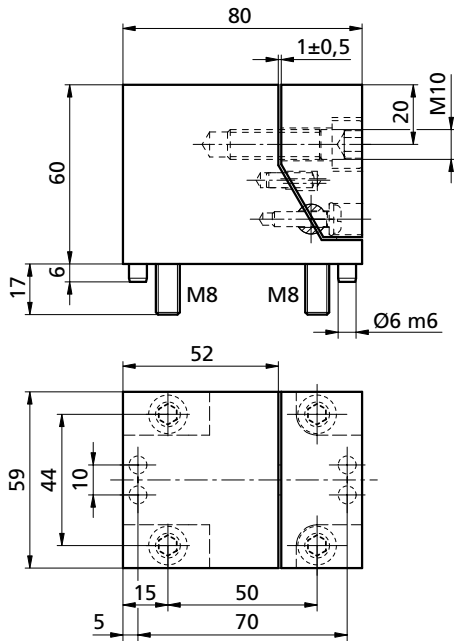

Spannstelle an Werkstück
angepasst und nitriert.
Clamping face machined to
the shape of the workpiece
and nitrided.

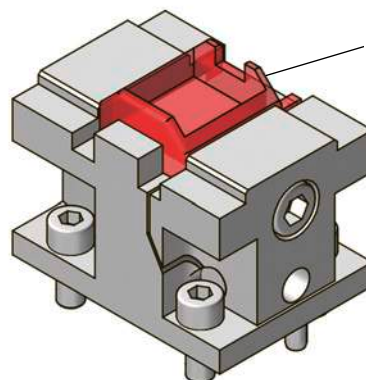

*VS1X59L60K

- ① 1x VS1X59L60H5KA
 - ② 1x VS1X59L60H5KS
 - ③ 1x M10X35ISO4762
 - ④ 1x M5X20DIN85A
 - ⑤ 1x ORØ8x1,5
 - ⑥ 4x **M8X25ISO4762**
 - ⑦ 1x VS1X59L60H5KG
 - ⑧ 2x 6m6x14 DIN 6325
- kg ~1,89

VS1X59L60H5

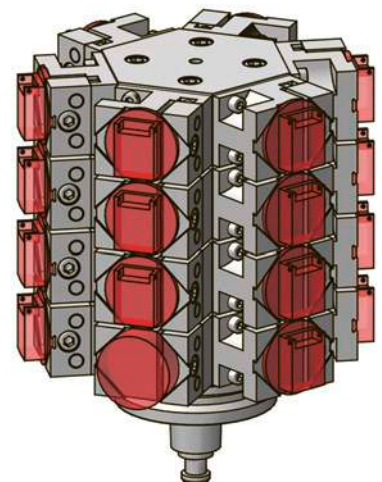
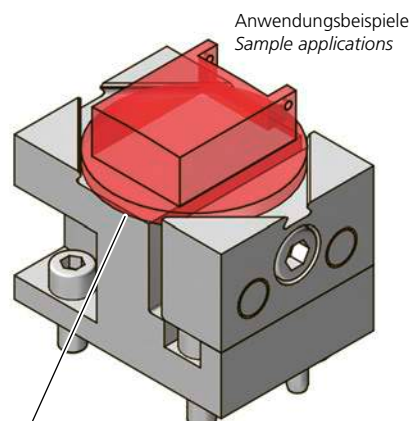
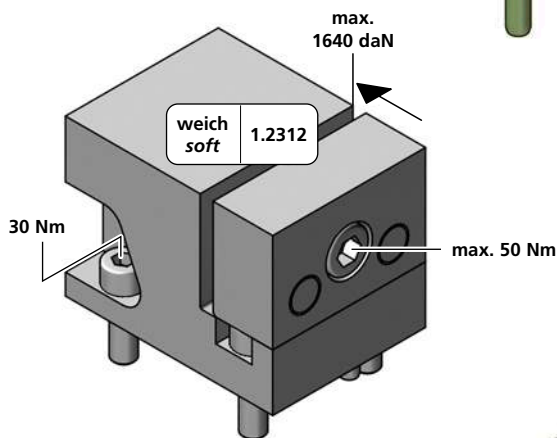
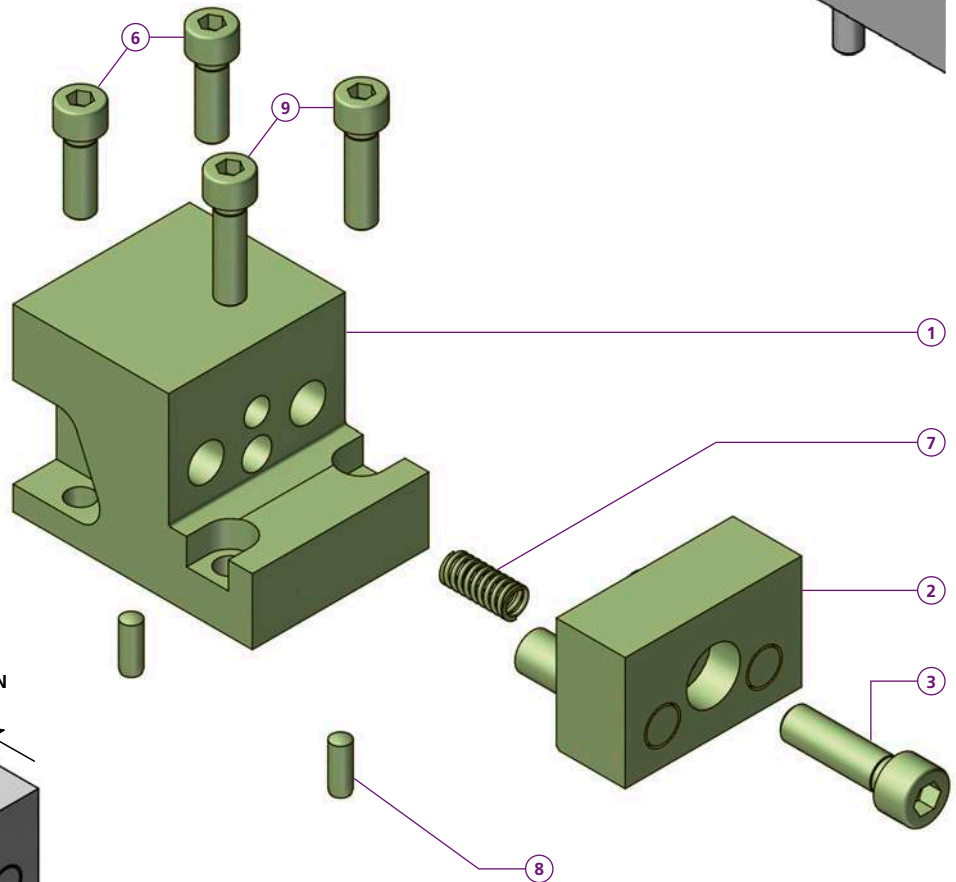
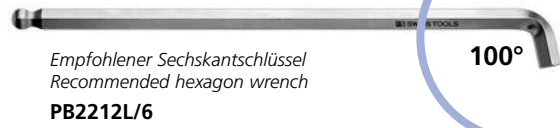
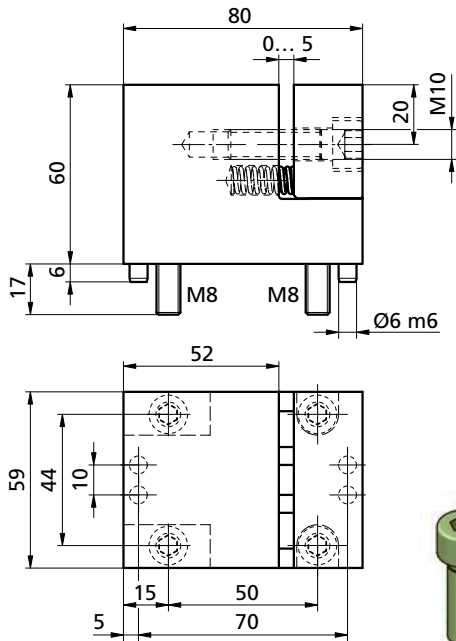

Spannstelle an Werkstück angepasst und nitriert.
Clamping face machined to the shape of the workpiece and nitrided.

| *VS1X59L60H5 | |
|--------------|------------------------|
| 1 | 1x VS1X59L60H5A |
| 2 | 1x VS1X59L60H5S |
| 3 | 1x M10X35ISO4762 |
| 6 | 2x M8X25ISO4762 |
| 7 | 1x FED0833 |
| 8 | 2x 6m6x14 DIN 6325 |
| 9 | 2x M8X30ISO4762 |
| kg | ~1,94 |

* = Stahl / steel 1.2312

Bestellbeispiel / Ordering example : **VS1X59L60H5**

Separat bestellen / Order separately

| durchgehärtet / through hardened | | | | | | | | | | nitriert / nitrated | | | | | | | | | |
|----------------------------------|----------|----------|----------|-----------|-------------|----------|----------|----------|-----------|---------------------|----------|----------|----------|-----------|-------------|----------|----------|----------|-----------|
| 26mm | B | H | N | kg | 41mm | B | H | N | kg | 23mm | B | H | N | kg | 41mm | B | H | N | kg |
| CCU15026 | 26 | 15 | 2,2 | ~0,017 | CCU15081 | 41 | 15 | 2,2 | ~0,018 | MCU11037 | 23 | 11 | 2 | ~0,004 | CCU15083 | 41 | 15 | 3 | ~0,025 |
| CCU20026 | 26 | 20 | 2,2 | ~0,02 | CCU20081 | 41 | 20 | 2,2 | ~0,022 | MCU15037 | 23 | 15 | 2 | ~0,006 | CCU20083 | 41 | 20 | 3 | ~0,029 |
| CCU25026 | 26 | 25 | 2,2 | ~0,022 | CCU25081 | 41 | 25 | 2,2 | ~0,025 | MCU18037 | 23 | 18 | 2 | ~0,008 | CCU25083 | 41 | 25 | 3 | ~0,034 |
| CCU30026 | 26 | 30 | 2,2 | ~0,025 | CCU27581 | 41 | 27 | 2,2 | ~0,027 | MCU20037 | 23 | 20 | 2 | ~0,008 | CCU27583 | 41 | 27,5 | 3 | ~0,036 |
| CCU32526 | 26 | 32,5 | 2,2 | ~0,026 | CCU30081 | 41 | 30 | 2,2 | ~0,029 | MCU22537 | 23 | 22,5 | 2 | ~0,008 | | | | | |
| 38mm | B | H | N | kg | 80mm | B | H | N | kg | 26mm | B | H | N | kg | 80mm | B | H | N | kg |
| CCU30039 | 38 | 30 | 2,2 | ~0,028 | CCU15080 | 79 | 15 | 2,2 | ~0,019 | CCU15027 | 26 | 15 | 3 | ~0,024 | CCU15082 | 79 | 15 | 3 | ~0,026 |
| CCU35039 | 38 | 35 | 2,2 | ~0,031 | CCU20080 | 79 | 20 | 2,2 | ~0,027 | CCU20027 | 26 | 20 | 3 | ~0,027 | CCU20082 | 79 | 20 | 3 | ~0,036 |
| CCU40039 | 38 | 40 | 2,2 | ~0,035 | CCU25080 | 79 | 25 | 2,2 | ~0,035 | CCU25027 | 26 | 25 | 3 | ~0,03 | CCU25082 | 79 | 25 | 3 | ~0,045 |
| CCU45039 | 38 | 45 | 2,2 | ~0,039 | CCU27580 | 79 | 27,5 | 2,2 | ~0,039 | CCU30027 | 26 | 30 | 3 | ~0,033 | CCU27582 | 79 | 27,5 | 3 | ~0,049 |
| | | | | | CCU30080 | 79 | 30 | 2,2 | ~0,043 | CCU32527 | 26 | 32,5 | 3 | ~0,034 | | | | | |
| | | | | | CCU35080 | 79 | 35 | 2,2 | ~0,05 | | | | | | | | | | |
| | | | | | CCU40080 | 79 | 40 | 2,2 | ~0,057 | | | | | | | | | | |
| | | | | | CCU45080 | 79 | 45 | 2,2 | ~0,063 | | | | | | | | | | |

CCU

MCU

Schraubenzieher mit Konterung für
Screwdriver with holding sleeve for

CCBXSK

Positionsbolzen
Position pin

| | L | kg |
|----------|----|--------|
| CCBO0801 | 36 | ~0,006 |
| CCBO0802 | 20 | ~0,002 |
| CCBO0803 | 50 | ~0,01 |

Bolzen-Auszieher
Pin puller

CCAZ1050

Positionierstift (spreizbar)
Locating pin (expandable)

CCBX0802



Mehr Informationen siehe Zentrischspanner
For more information check the self centring vise **p. 116**

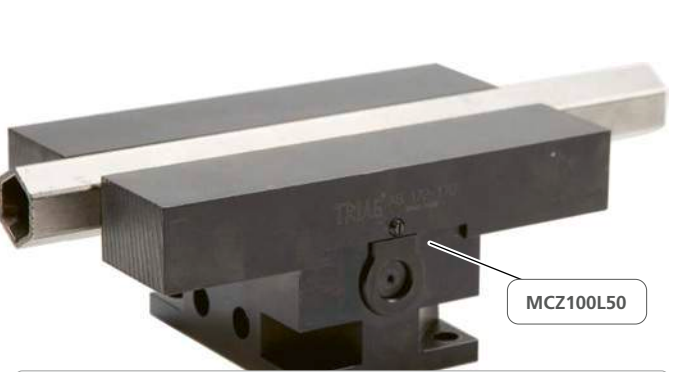

Mehr Informationen siehe Zentrischspanner
For more information check the self centring vise **p. 127**

Universalbacke / Universal jaw

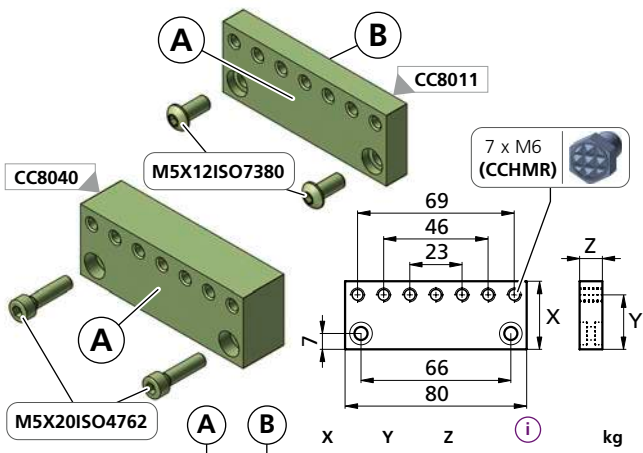

| Part No. | A | B | X | Y | Z | Material | Weight (kg) |
|----------|---|---|----|----|----|----------|-------------|
| CC8011 | | | 30 | 24 | 10 | 56 HRC | ~ 0,15 |
| CC8025 | | | 50 | 44 | 10 | 56 HRC | ~ 0,28 |
| CC8040 | | | 30 | 24 | 20 | * | ~ 0,33 |

Weiche Backe / Soft jaw

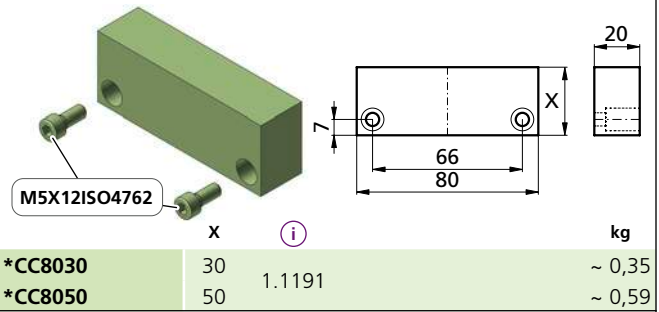

| Part No. | X | Weight (kg) |
|----------|----|-------------|
| *CC8030 | 30 | ~ 0,35 |
| *CC8050 | 50 | ~ 0,59 |

Backe mit 2 Pendeldruckstücken / Jaw with 2 swivelling balls

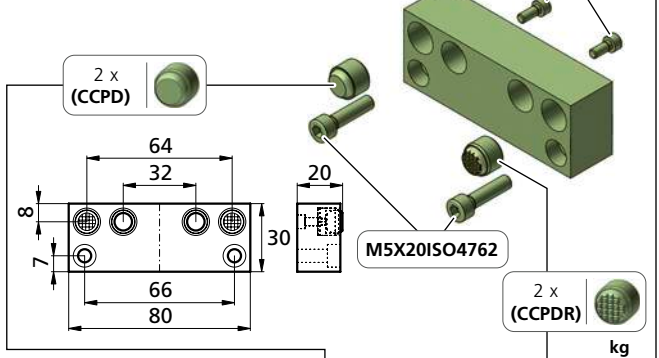

| Part No. | Weight (kg) |
|----------|-------------|
| CC8060 | ~0,30 |
| CC8060R | ~0,30 |

Backe für Druckstift / Jaw for pressure pin

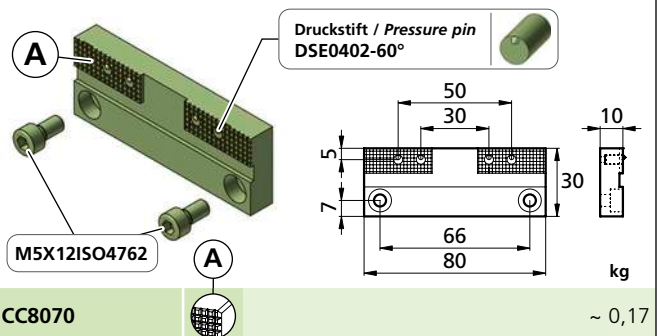

| Part No. | Weight (kg) |
|----------|-------------|
| CC8070 | ~ 0,17 |

Prismabacke / Prismatic jaw

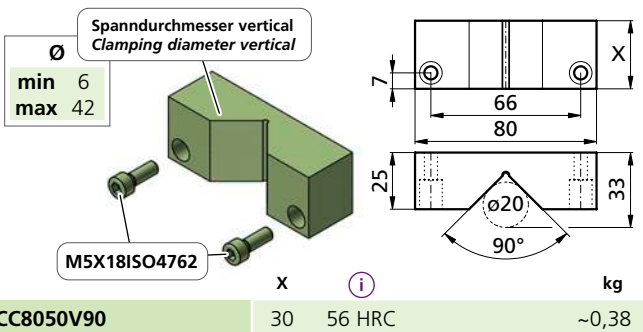

| Part No. | X | Material | Weight (kg) |
|-----------|----|----------|-------------|
| CC8050V90 | 30 | 56 HRC | ~0,38 |

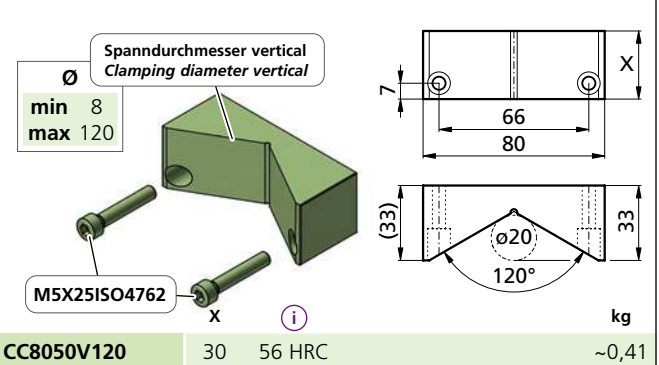

| Part No. | X | Material | Weight (kg) |
|------------|----|----------|-------------|
| CC8050V120 | 30 | 56 HRC | ~0,41 |

Backe / Jaw

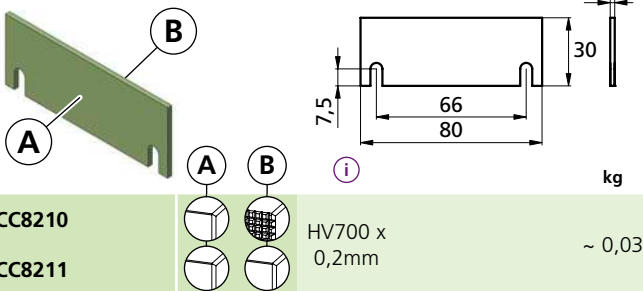

| Part No. | Material | Weight (kg) |
|----------|---------------|-------------|
| CC8210 | HV700 x 0,2mm | ~ 0,03 |
| CC8211 | HV700 x 0,2mm | ~ 0,03 |

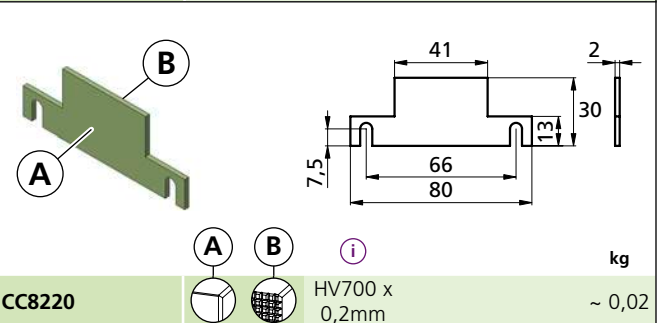

| Part No. | Material | Weight (kg) |
|----------|---------------|-------------|
| CC8220 | HV700 x 0,2mm | ~ 0,02 |

* = weicher Stahl / soft steel

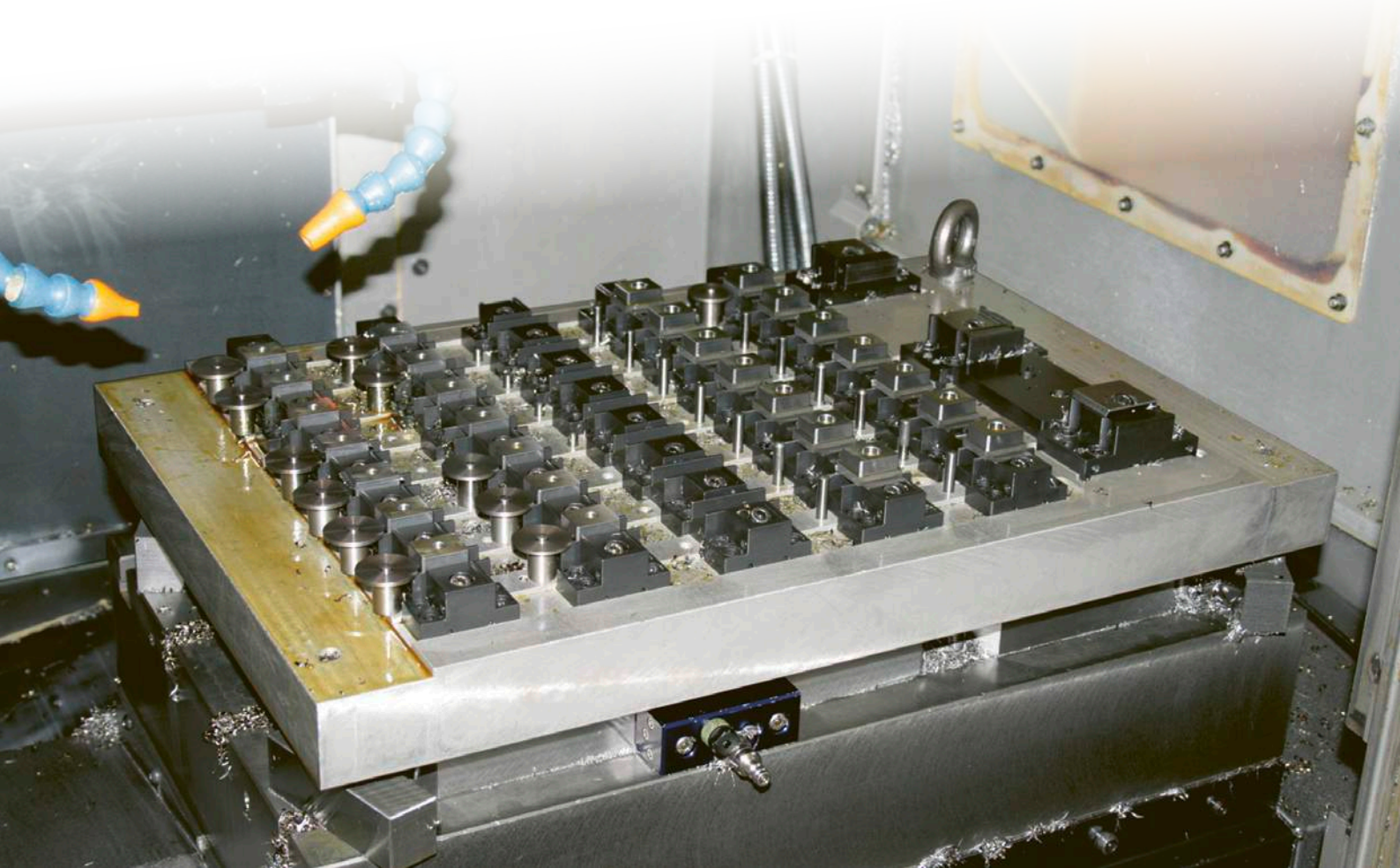
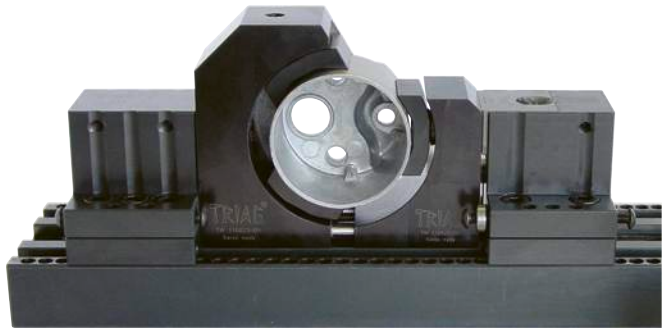
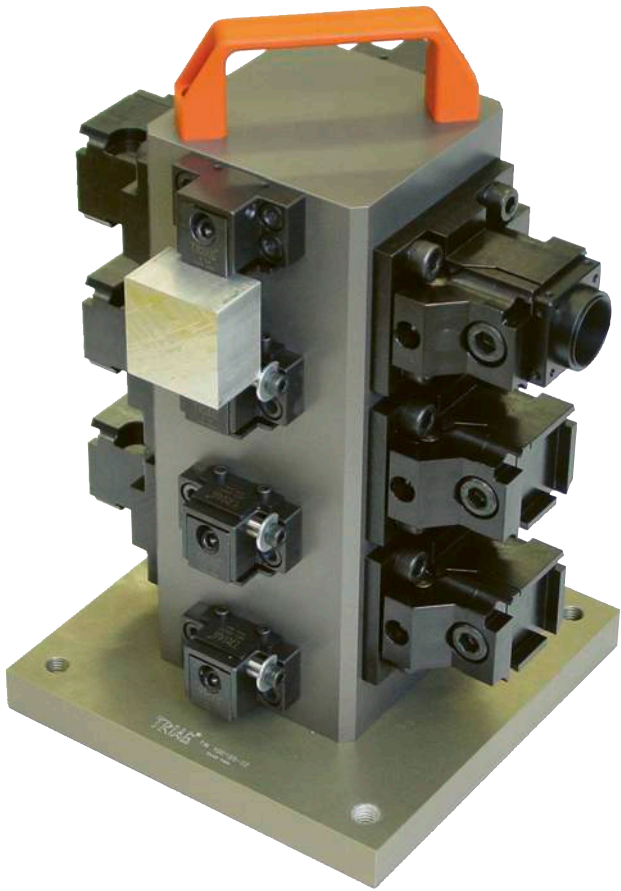

Bestellbeispiel / Ordering example: CC8011



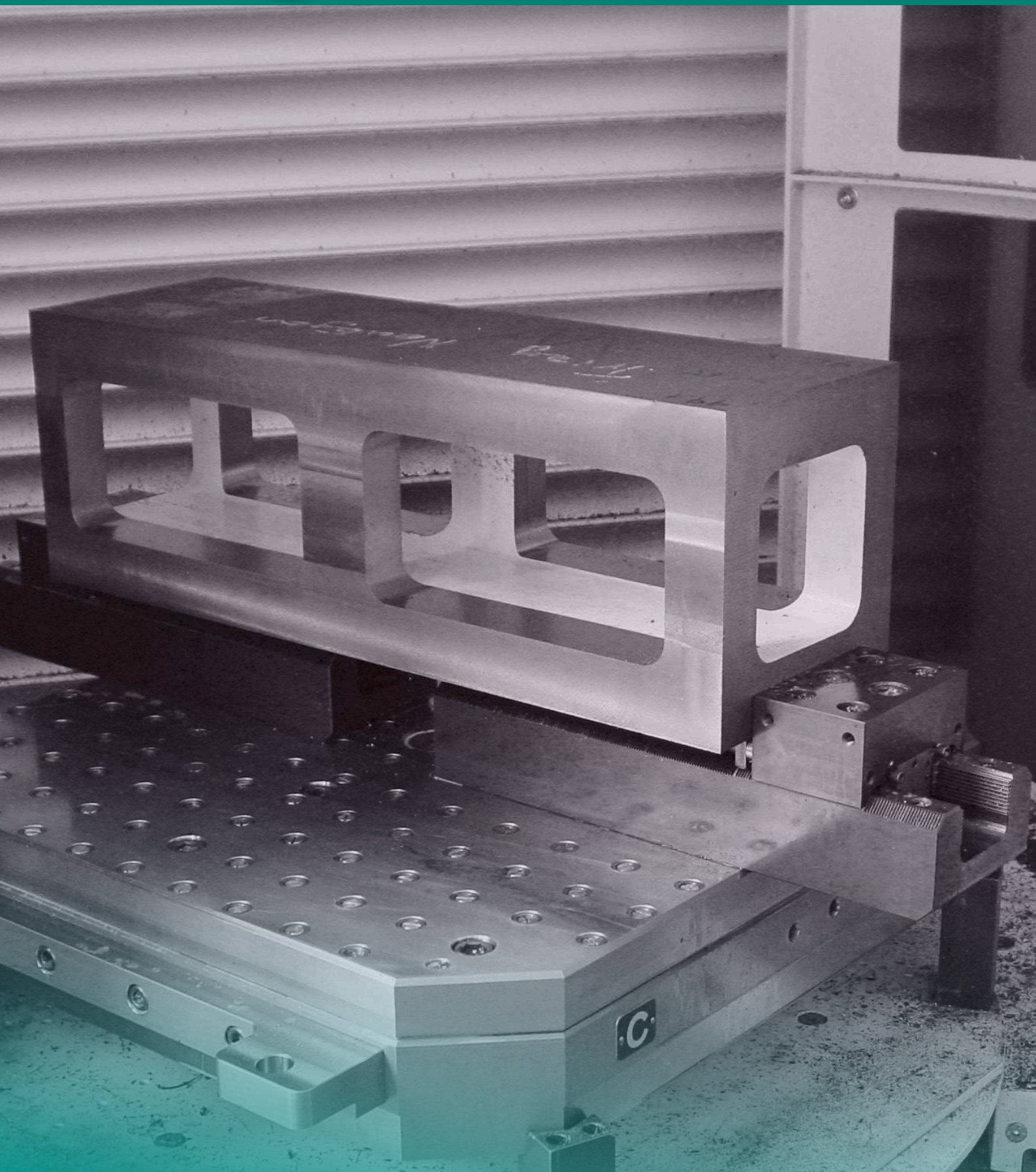

*apto*CLAMP & *5axes*

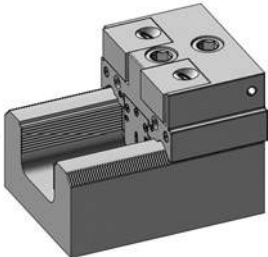
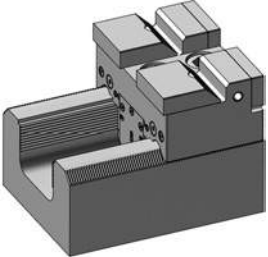
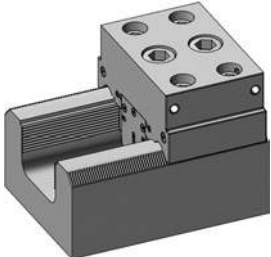
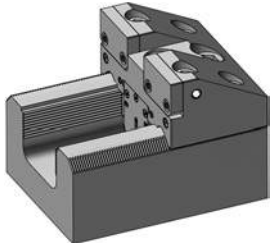
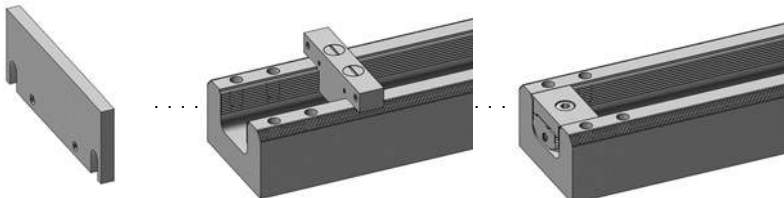

| | | |
|---|--|---|
|  | Einleitung <i>Introduction</i> | 209 - 212 |
|  | Bedienungsanleitung <i>Operating manual</i> | 213 - 214 |
| | Anwendungsbeispiele <i>Examples of application</i> | 215 - 220 |
| | Basisschiene <i>Base-rail</i> | 222 |
| | |  |
| | Niederzugspannmodule <i>Pull down clamp modules</i> | 223 - 226 |
| | |  |
| | Linearspannmodule mit Präge- und Linearbacken <i>Linear clamping modules with stamping and linear jaws</i> | 227 |
| | |  |
| | Anschlagmodule <i>End module</i> | 228 - 230 |
| | |  |
| | 5-Achs Linearanschlagmodule mit Präge- und Linearbacken <i>5-axis linear clamping modules with stamping and linear jaws</i> | 231 |
| | |  |
| | Zubehör <i>Accessories</i> | 232 - 233 |
| | |  |

Die Idee des Mehrfachspannens The idea of multiple workholding

Schwerstzerspannung / Heavy duty machining

aptoCLAMP

Die hohe Spannkraft dieses Systems ermöglicht den Einsatz für schwere Zerspanung.

Mit stabilen Kraftspannern können auf den Basisschienen auch grosse, bis zu mehrere tausend Kilogramm schwere Platten und Blöcke gespannt werden.

The high clamping force of the Apto Clamp enables heavy cuts. You achieve maximum rigidity with our Apto Clamp modular system! Even if your workpiece is thousands of kilograms you don't have to worry to clamp big parts and big plates.

Elefantenstark und anwenderfreundlich Powerful and user-friendly



Zur Positionierung der Spannmodule hat das Apto Clamp neben einer Querverzahnung zusätzlich ein Ankersystem zur Arretierung an einer Längsverzahnung in der Basischiene. Durch die rechtwinklige Verteilung wird eine von Mitbewerbern unerreichte Stabilität gewährleistet. Die Spannmodule liegen auf der genau geschliffenen Auflagefläche der Basis auf. Durch das Ankersystem und die geschliffene Auflagefläche wird das Spannmodul an der Basischiene extrem kraftschlüssig und präzise fixiert. Trotzdem können die Spannmodule völlig ungehindert entlang der Basis verstellt (verschoben) werden. Auch das Auswechseln der Module ist einfach, müssen doch diese nicht aus der Schiene ausgefahren, sondern können abgehoben werden.

For positioning the clamp modules on the base rails, has the Apto Clamp system next to a positioning serration a horizontal anchor system for locking with enormous force produced by two M16 screws. The end modules have additionally 4 M12 screws to give extra rigidity.



The end modules have additionally 4 M12 screws to give extra rigidity.

Schnelligkeit / Quickness



Zwei Schraube lösen
Loosen two screws



Abheben und neu platzieren
Lift and change position



Zwei Schrauben anziehen
Fasten two screws

Vorteile auf einen Blick / Benefits at a glance:

- Sehr stabil, robuste Bauweise, dadurch hohe Präzision
Very stable, robust design allows high precision and heavy machining
- Module nach oben abhebbar, kein Ausfahren nötig
Modules can be lifted up, no extension needed
- Keine verschmutzbaren T-Nuten: Formschlüssig positioniert
No chip loading T-slots grooves: Positively positioned
- Verzahnung nicht dem Werkstück ausgesetzt
The teeth are not exposed to the workpiece
- Niederzug- und Linearspannung möglich
Pull-down and linear clamping possible
- Spannkraft bis 7000 daN pro Modul
Clamping force up to 7000 daN per module

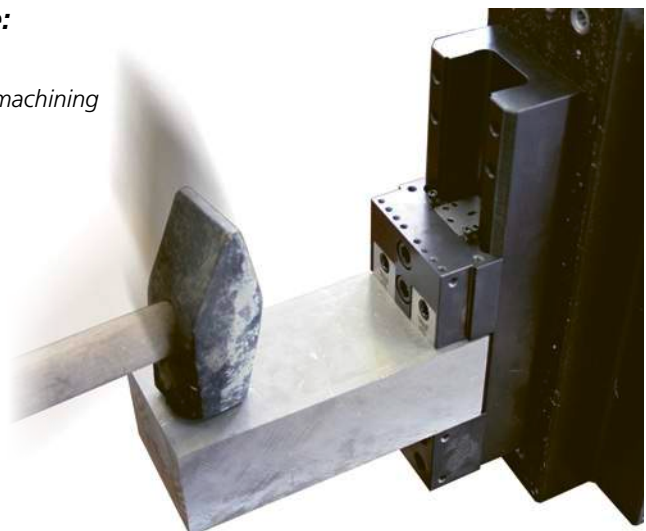

400 mm

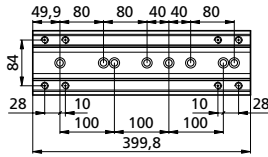

450 mm

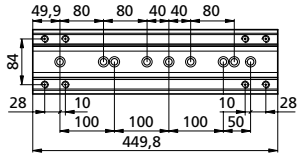

500 mm

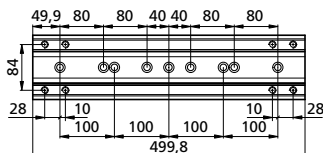

550 mm

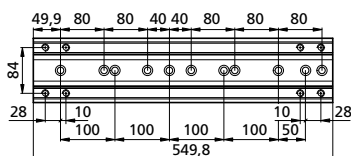

600 mm

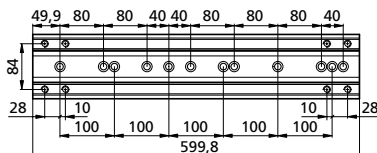

650 mm

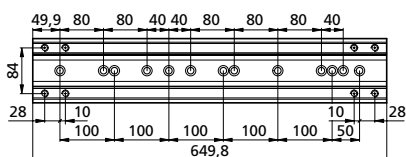

700 mm

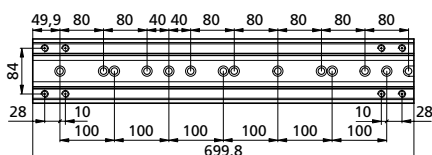

750 mm

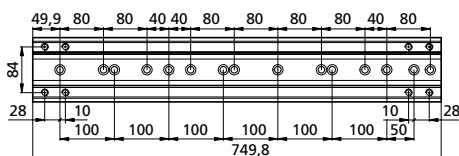

800 mm

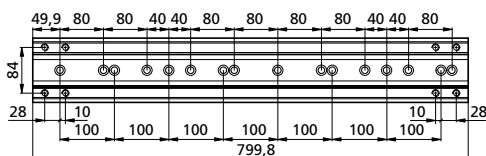

Basisschiene / Base rail

Beim Apto Clamp ermöglicht eine Verzahnung mit 2 mm-Teilung auf der Basisschiene ein schnelles und genaues Positionieren der Spann- und Anschlagmodule.

With the new Apto Clamp a serration of 2mm pitch on the base rail allows a rapid and accurate positioning of the modules.

Durch gezielte elastische Deformation einer Lippe erfolgt eine spielfreie Paarung. Spann- und Bearbeitungskräfte werden einerseits an der ebenen, robusten Oberseite der Basisschiene aufgenommen, während andererseits das Spannmodul durch einen spreizenden Keil mit robustem Rundgewindeprofil in der Schiene verankert wird.

The outstanding development is that through elastic deformation of a lip, the engagement between the modules and the base rail is without play. Clamping and machining forces are absorbed on the upper surface of the base rail whereas the vice module is fixed to the rail by an expandable anchor which engages the round serration inside the base rail.

Das Einfügen zusätzlicher Module zwischen bestehenden Spannstellen ist problemlos möglich. Apto Clamp ist die konsequente Weiterentwicklung von Power Clamp zur Bearbeitung noch grösserer Werkstücke.

The insertion of additional vice modules can be accomplished without problems. Apto Clamp is the logical development of Power Clamp to handle even larger work pieces.

Schnittzeichnung Sectional view of der Basisschiene the base rail

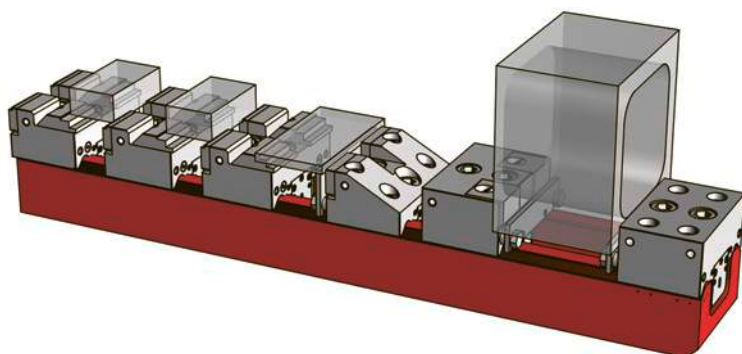
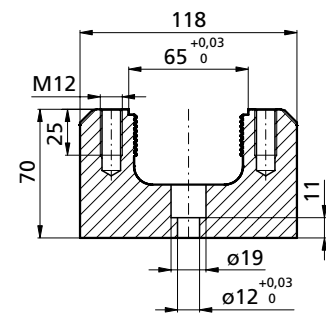

Das Anschlagmodul / End modules

In der Regel ist nur ein Anschlagmodul als „feste Backe“ erforderlich.

In general, only a stop module is required as a „fixed jaw.“

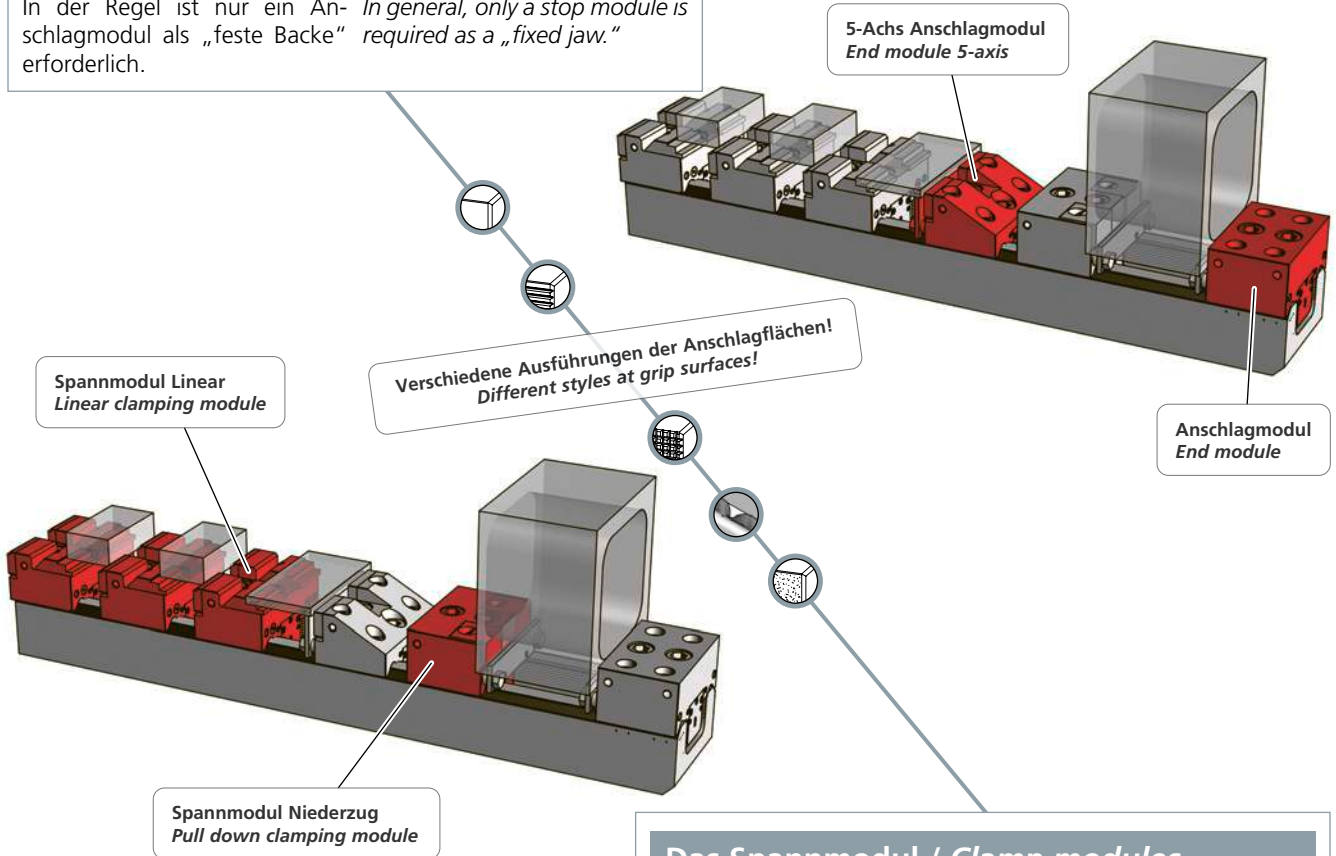

Das Spannmodul / Clamp modules

Die «beweglichen Backen» gibt es in zwei Ausführungen. Zum einen für das Niederzugspannsystem und zum anderen für das Linearspannsystem. Dabei dient das Spannmodul bei den Systemen wiederum als Anschlagmodul für die nächste Aufspannung.

Clampe modules have movable jaws (linear or pull down) in the front to clamp the part and on the back there is the datum face for the next work piece stop. Positioning step on the base rail is 2mm every.

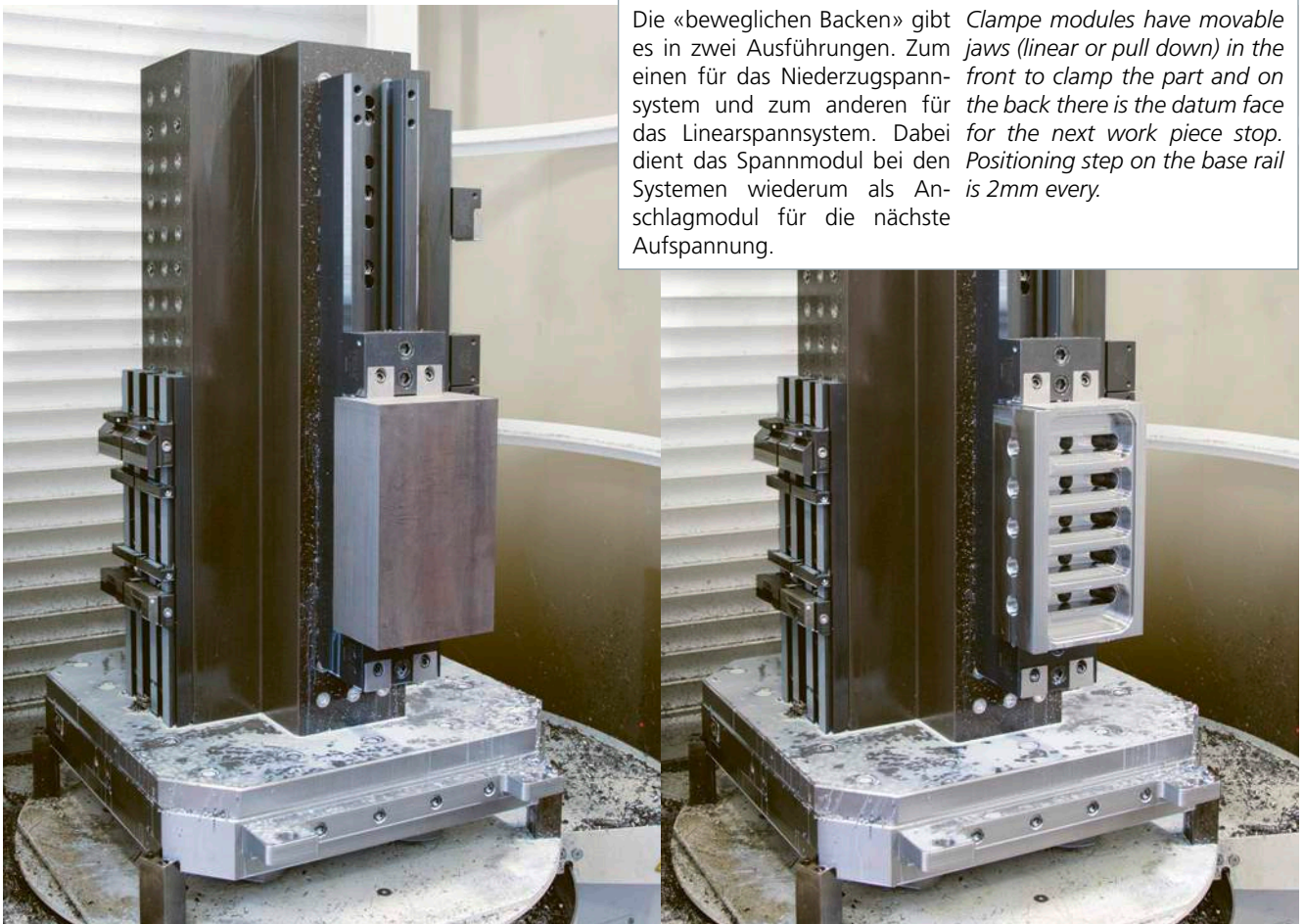

Niederzugspannmodule Pull down clamp modules

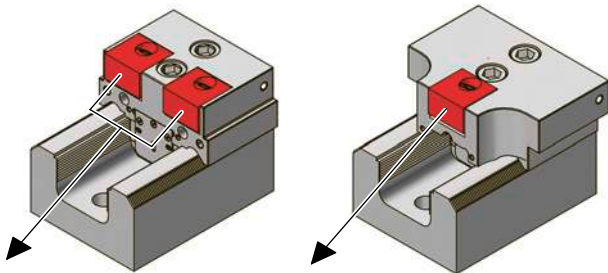

Die Fakten beim Niederzugspannsystem

Verstellbereich: 0- 3,8 mm
Spannkraft: Bis 7'000 daN

Vorteile beim Niederzugspannsystem:

- Höhere Haltekräfte
- Hohe Wiederholgenauigkeit
- Optimale Spannmethode für Kleinteile
- Mit Schnellwechselbacken
- Doppelspannsystem in einer Backe zum Spannen und Bearbeiten von zwei Kleinteilen

Facts for pull down clamp modules

Jaw range: 0- 3,8 mm
Clamping force: up to 7'000 daN

Advantages pull down jaws:

- Higher holding force
- With linear adaptable jaws
- Also with pull down jaws for the stop side available
- With adapter set can be changed to linear
- Also pull down jaws for datum face

Linearspannmodule Linear clamp modules

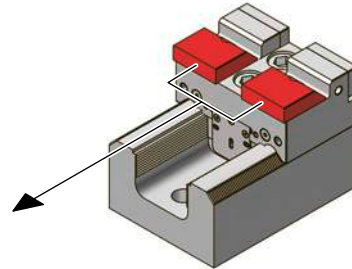

Die Fakten beim Linearspannsystem

Verstellbereich: 0- 5,0 mm
Spannkraft: Bis 3'200 daN

Vorteile beim Linearspannsystem:

- Spannstockähnliches Spannen
- Prozesssichere Positionierung der zweiten Aufspannung
- Gut geeignet für die Erstellung von individuellen Formbacken
- Sicherer Halt mit Prägetechnik

Facts for linear clamp modules

Jaw range: 0- 5,0 mm
Clamping force: up to 3'200 daN

Advantages linear jaws:

- Similar clamp as conventional vise
- Good for shaped jaws
- Secure clamped with direct stamping jaws
- Higher accuracy

Universalnutstein Universal nut

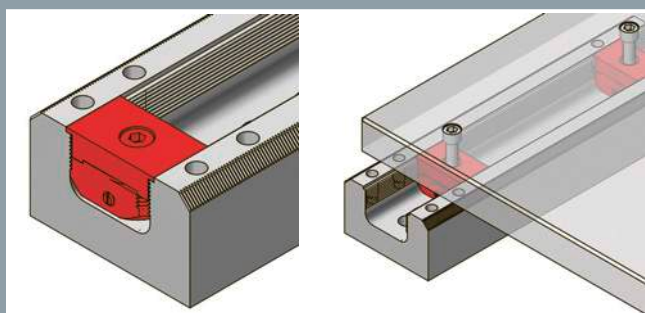

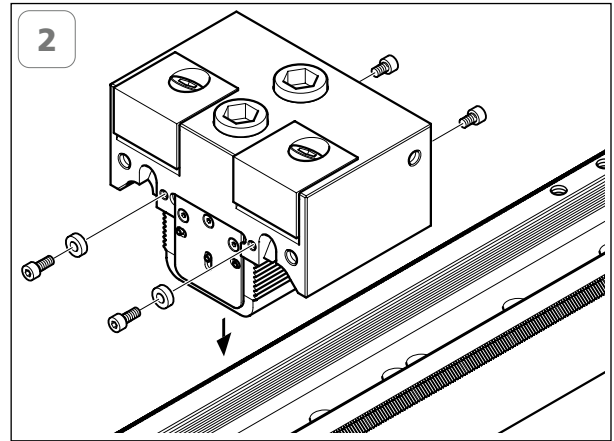
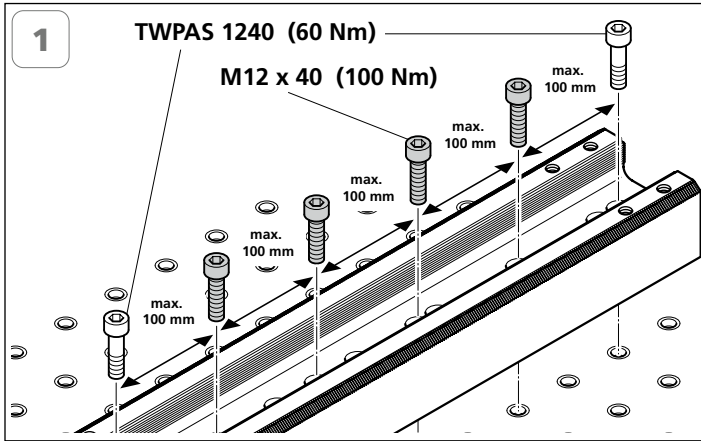

Ineinandergreifen der Verzahnung prüfen
Check matching of the teeth

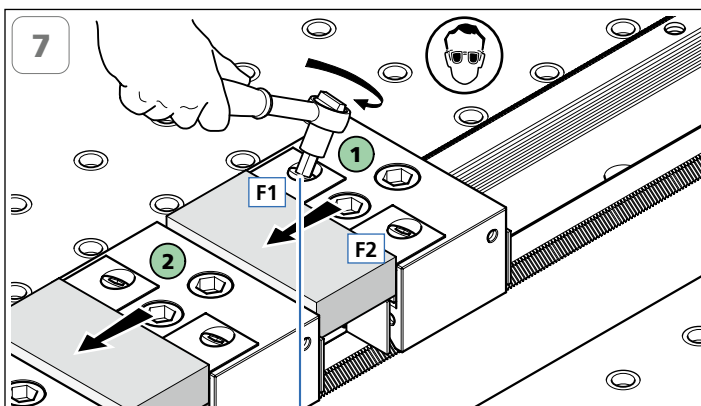
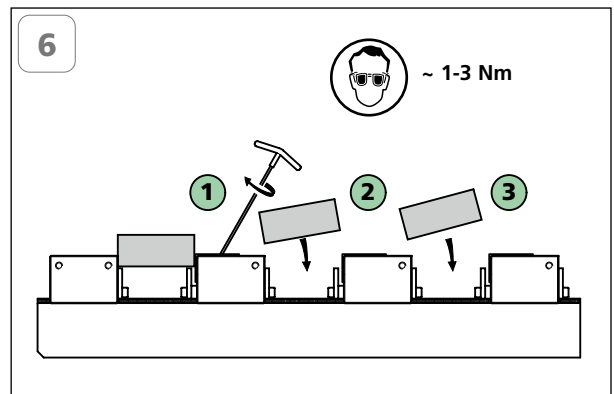
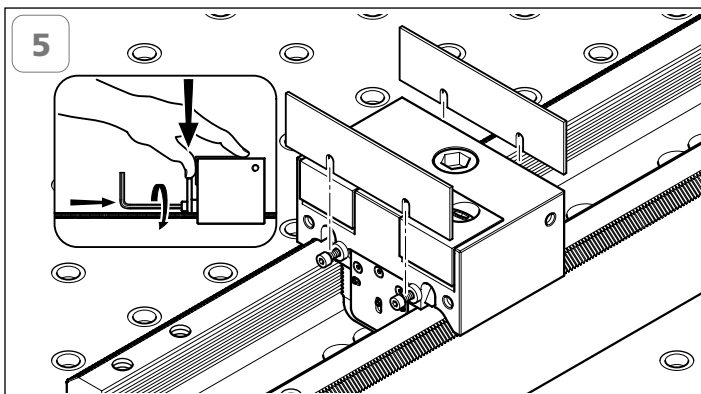
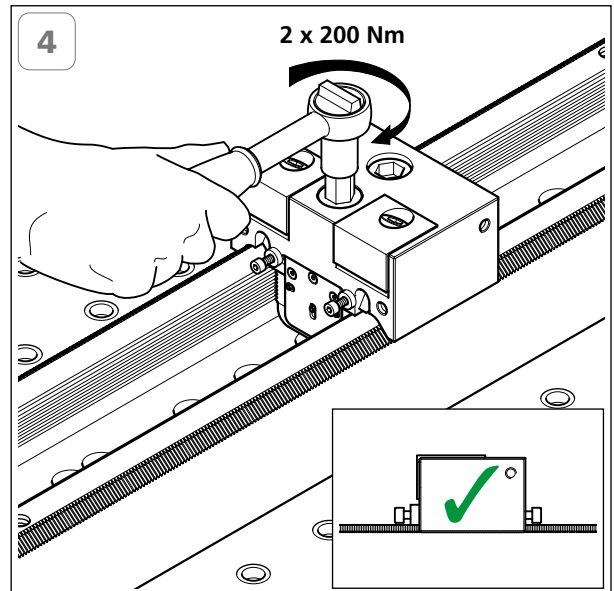
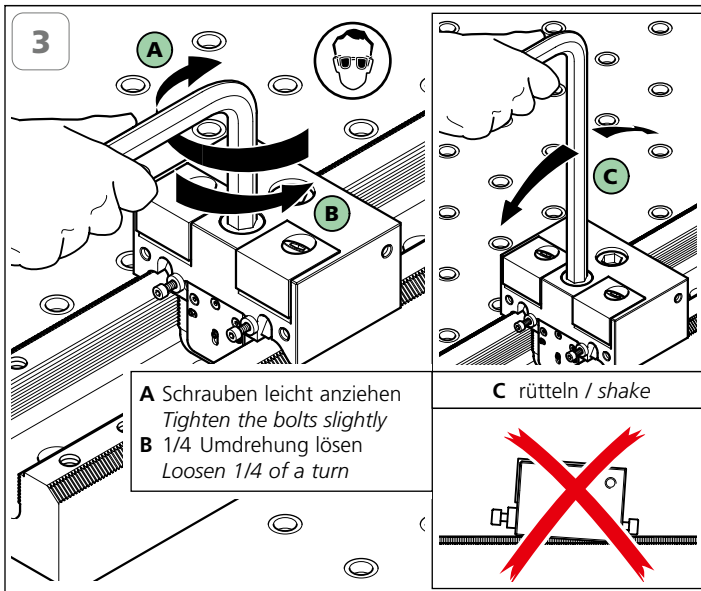

max. Drehmoment beachten
Observe max. torque

| Schraube Screw | Drehmoment Torque | | Spannkraft (F1 & F2) Workholding force (F1 & F2) | | |
|-------------------|----------------------|---------|---|--------|-----|
| | Nm | (lb-ft) | ~daN | ~(lb) | ~t |
| M10 | 10 | 7,4 | = 1200 | 2'650 | 1,2 |
| | 20 | 14,8 | = 2700 | 5'950 | 2,7 |
| | 30 | 22,2 | = 4100 | 9'040 | 4,1 |
| | 40 | 29,5 | = 5600 | 12'350 | 5,6 |
| | 50 | 37,0 | = 7000 | 15'430 | 7,0 |

max. Nm

ACHTUNG / CAUTION

WICHTIG: Die angegebenen Drehmomente sind die absoluten Maximalwerte. Über die Spannkräfte gibt die untenstehende Tabelle Auskunft.

IMPORTANT: The torque numbers specified represent the absolute maximum. The table at the bottom of this page provides further information on the workholding forces.

| Schraube Screw | Drehmoment Torque | | Spannkraft (F1 & F2) Workholding force (F1 & F2) | | |
|-------------------|----------------------|---------|---|--------|-----|
| | Nm | (lb-ft) | ~daN | ~(lb) | ~t |
| M10 | 10 | 7,4 | = 1200 | 2'650 | 1,2 |
| | 20 | 14,8 | = 2700 | 5'950 | 2,7 |
| | 30 | 22,2 | = 4100 | 9'040 | 4,1 |
| | 40 | 29,5 | = 5600 | 12'350 | 5,6 |
| | 50 | 37,0 | = 7000 | 15'430 | 7,0 |

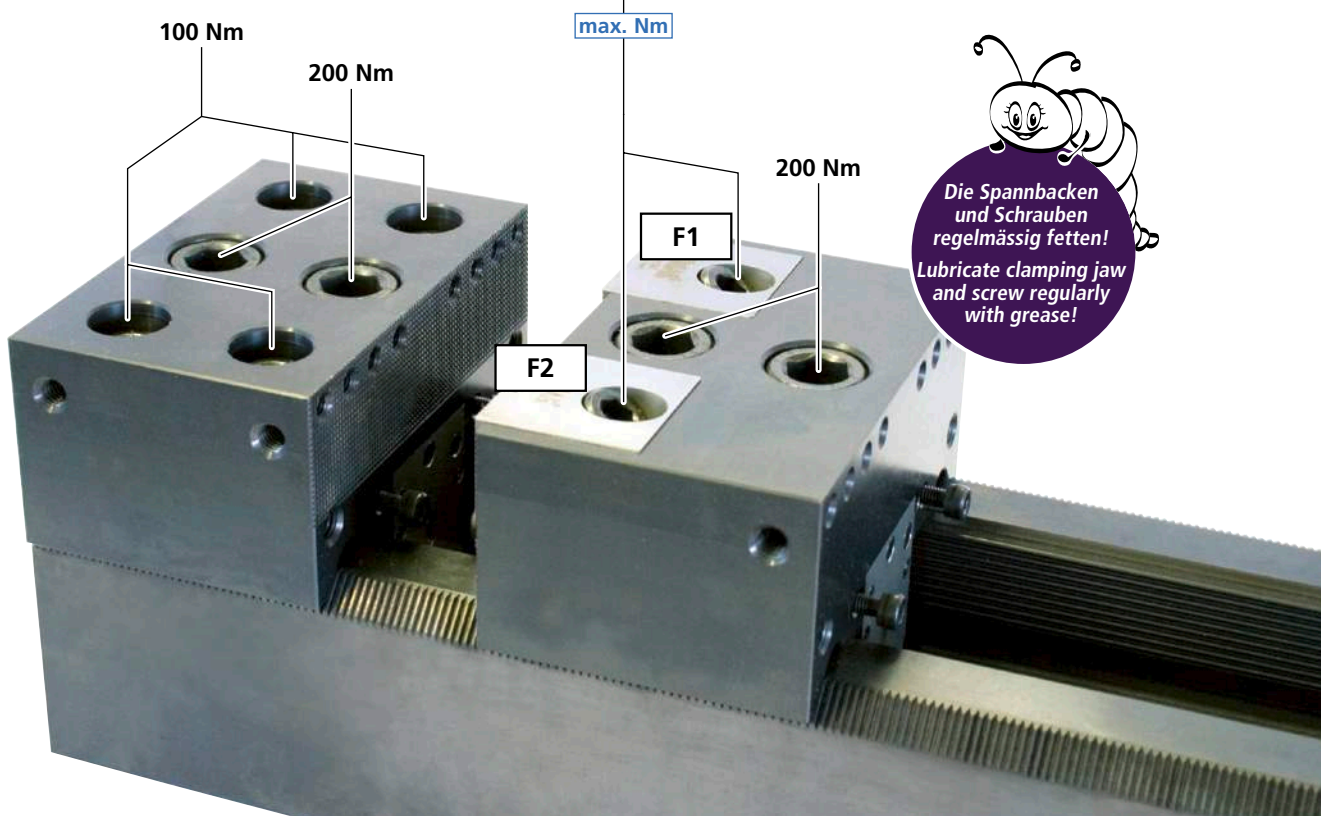

WICHTIG:

Vor dem Positionieren der Spannmodule für ein neues Werkstück ist die Spannbacke ganz zurück zu stellen, dies gewährleistet eine sichere Spannung (siehe Bild A)!

IMPORTANT:

Prior to setting up a new clamping module the clamping jaw of the vice module must be retracted all the way (see picture A)! This guaranties proper clamping of the new workpiece.

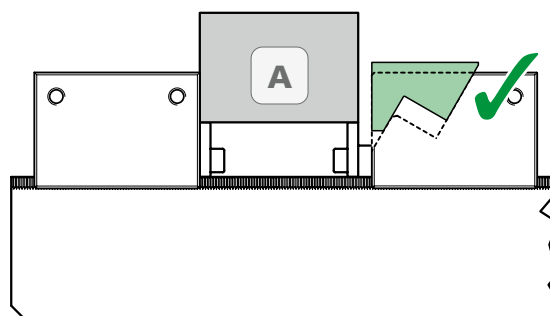
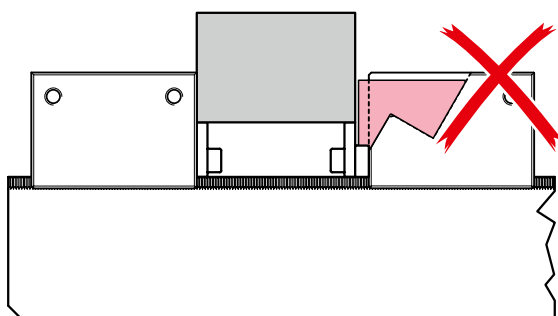

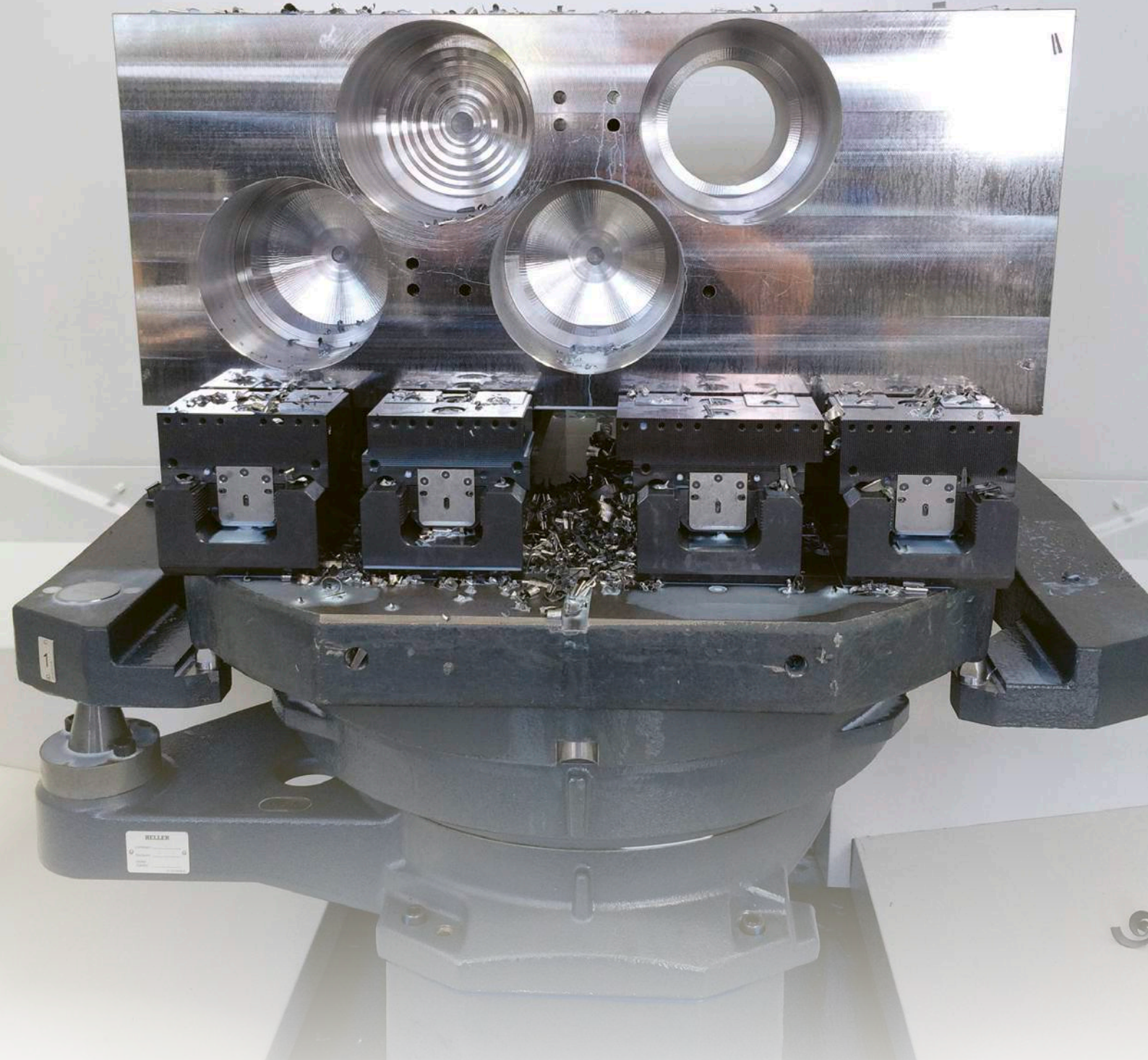

| | |
|--------------------------------|----------|
| Material | 42Cr Mo4 |
| Bearbeitung mit Fräskopf | Ø 200 |
| Machining with milling head | |
| Bohrer / Drills | Ø 124 |
| Einspanntiefe / Clamping depth | 24mm |

Apto Clamp in der Schwerzerspannung auf Heller 5-Achsen-Maschine
Apto Clamp for heavy duty machining on a 5-axis machine

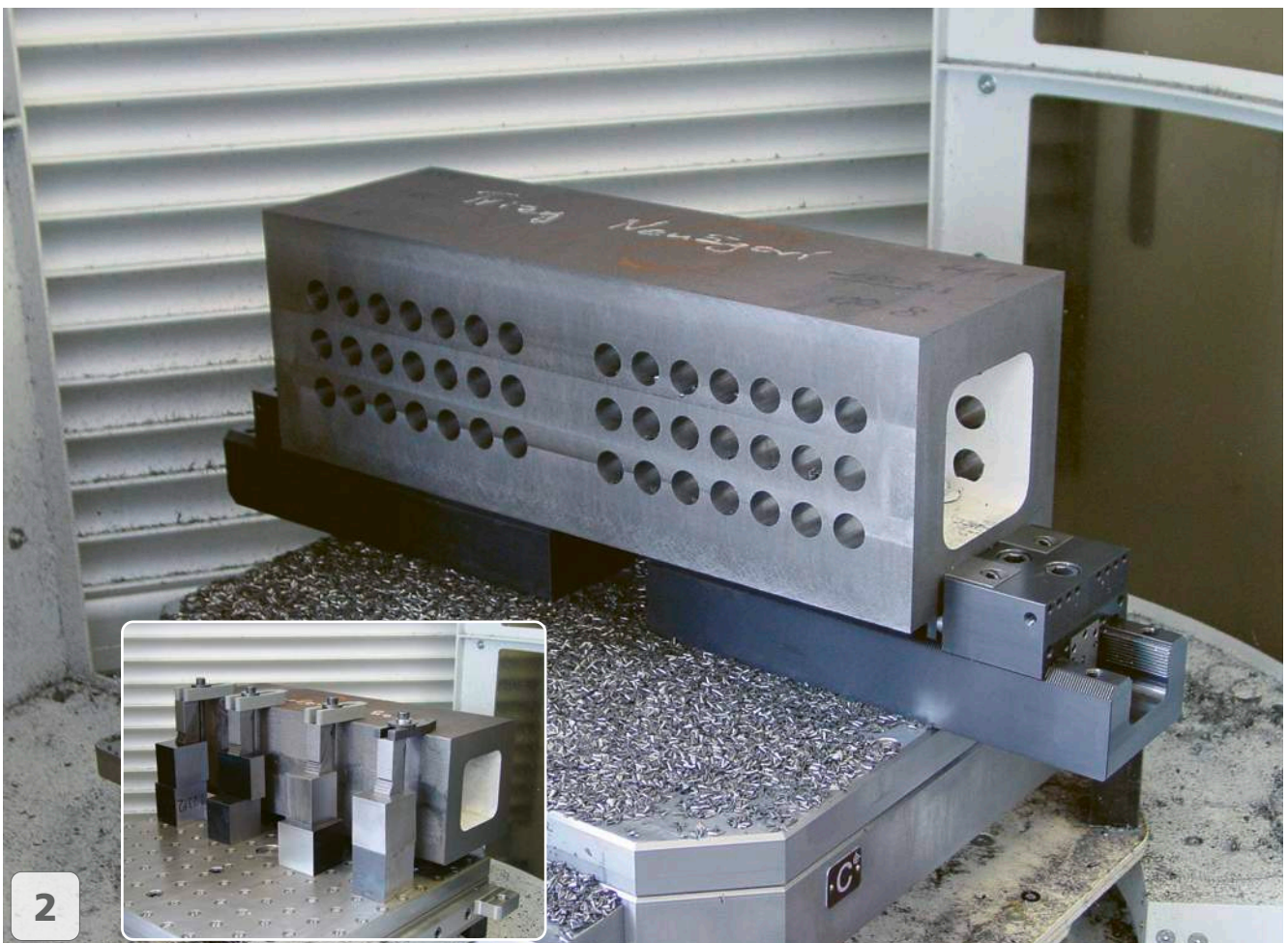
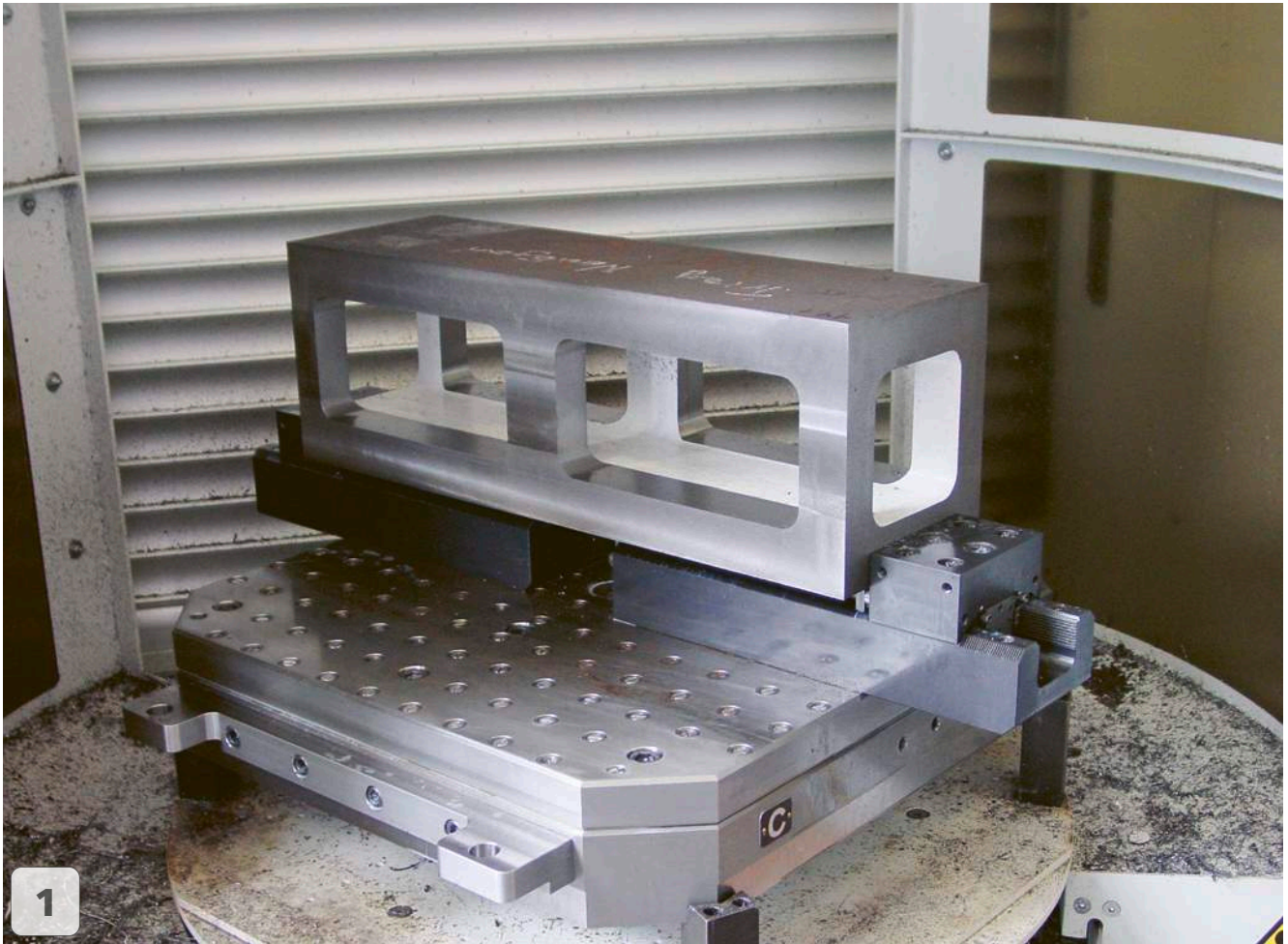

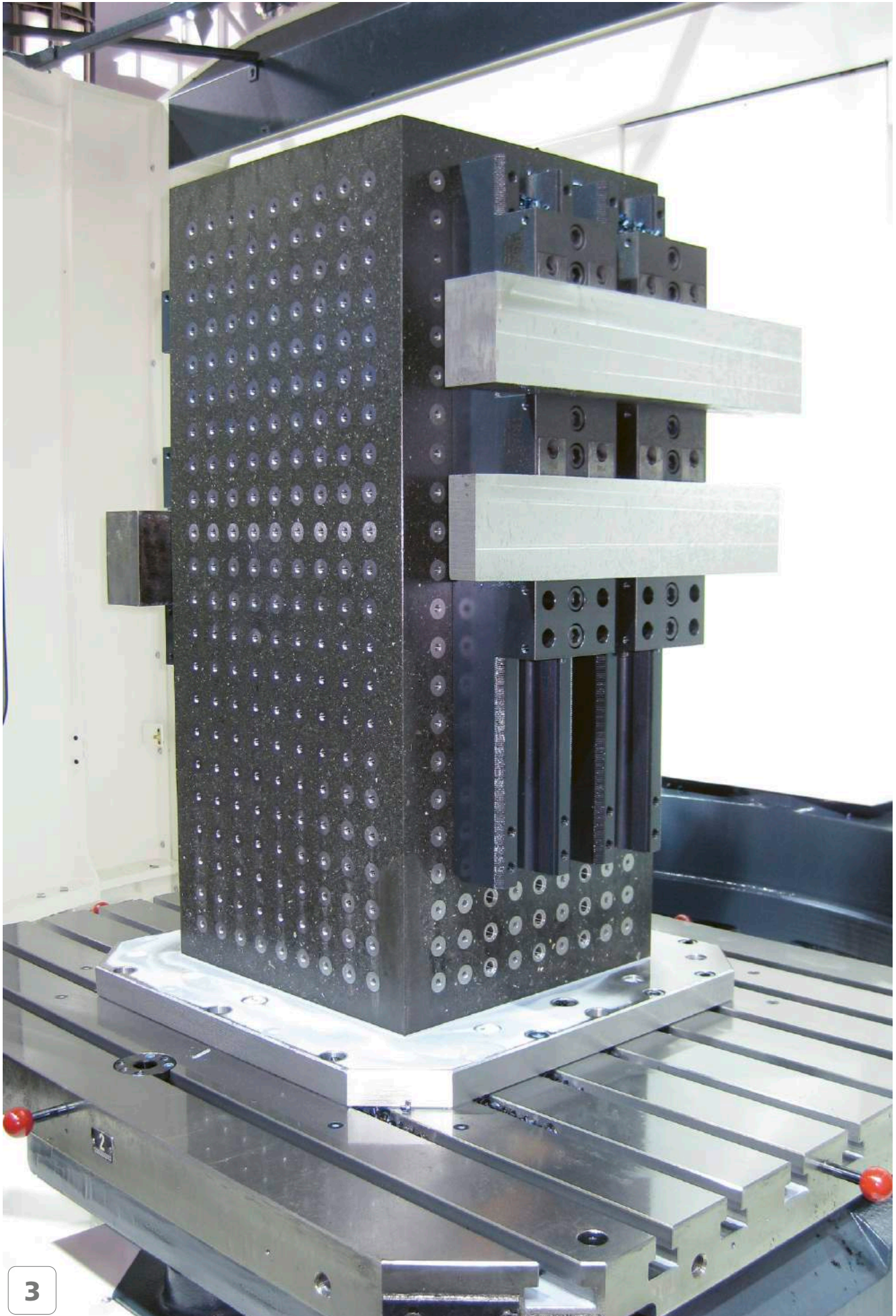

3

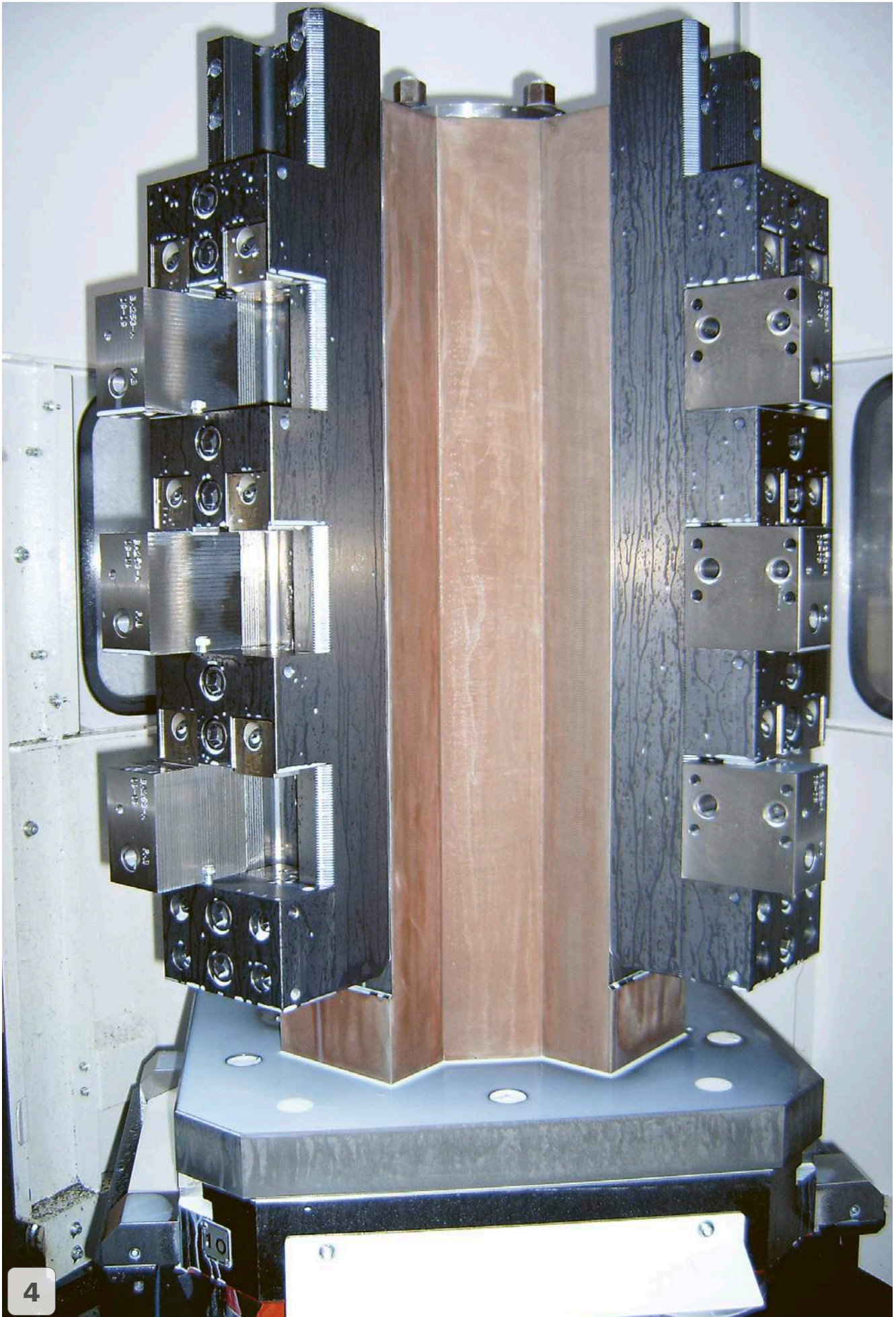

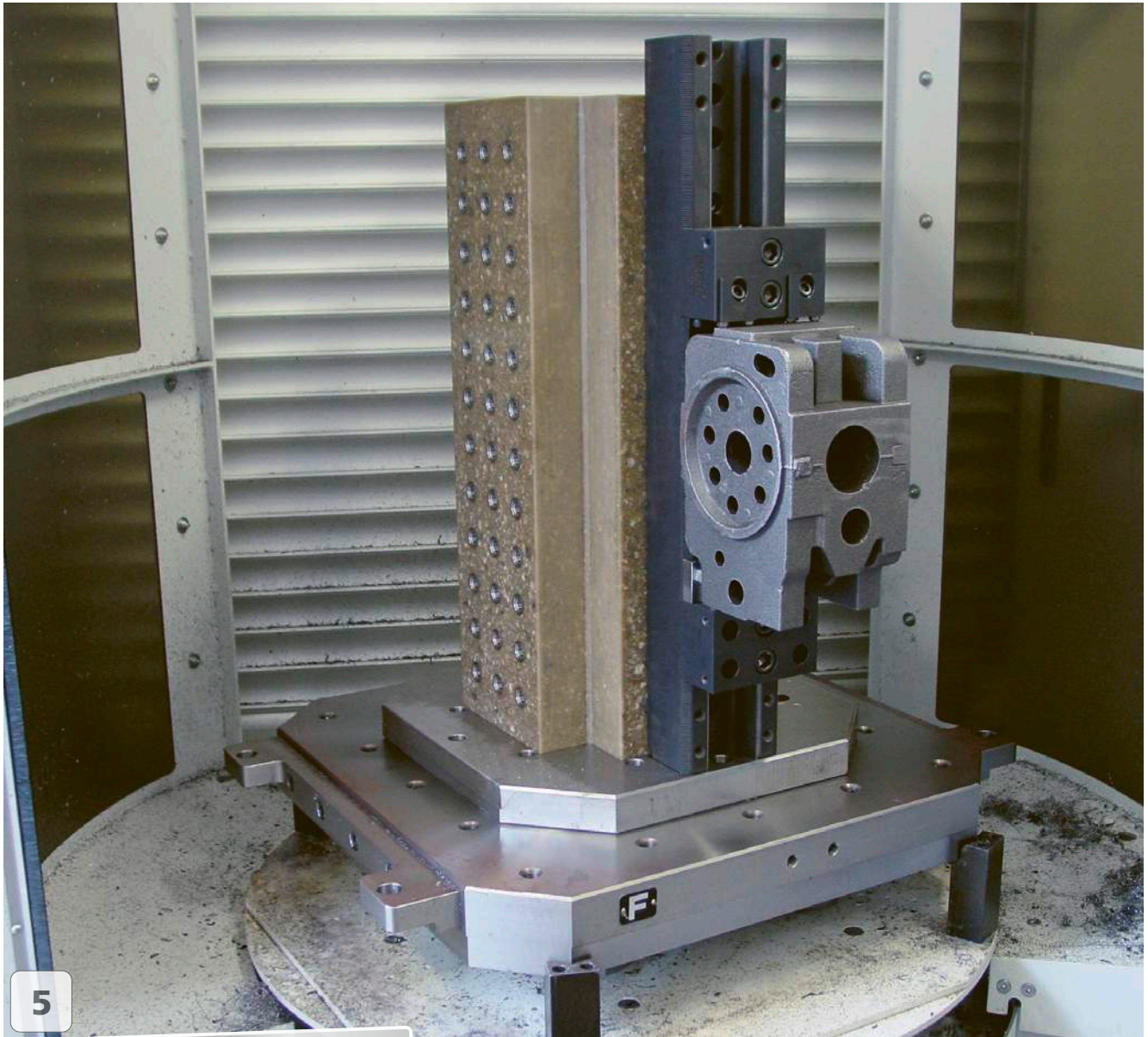

5

VERTICAL (3-4 ACHSEN/AXES)

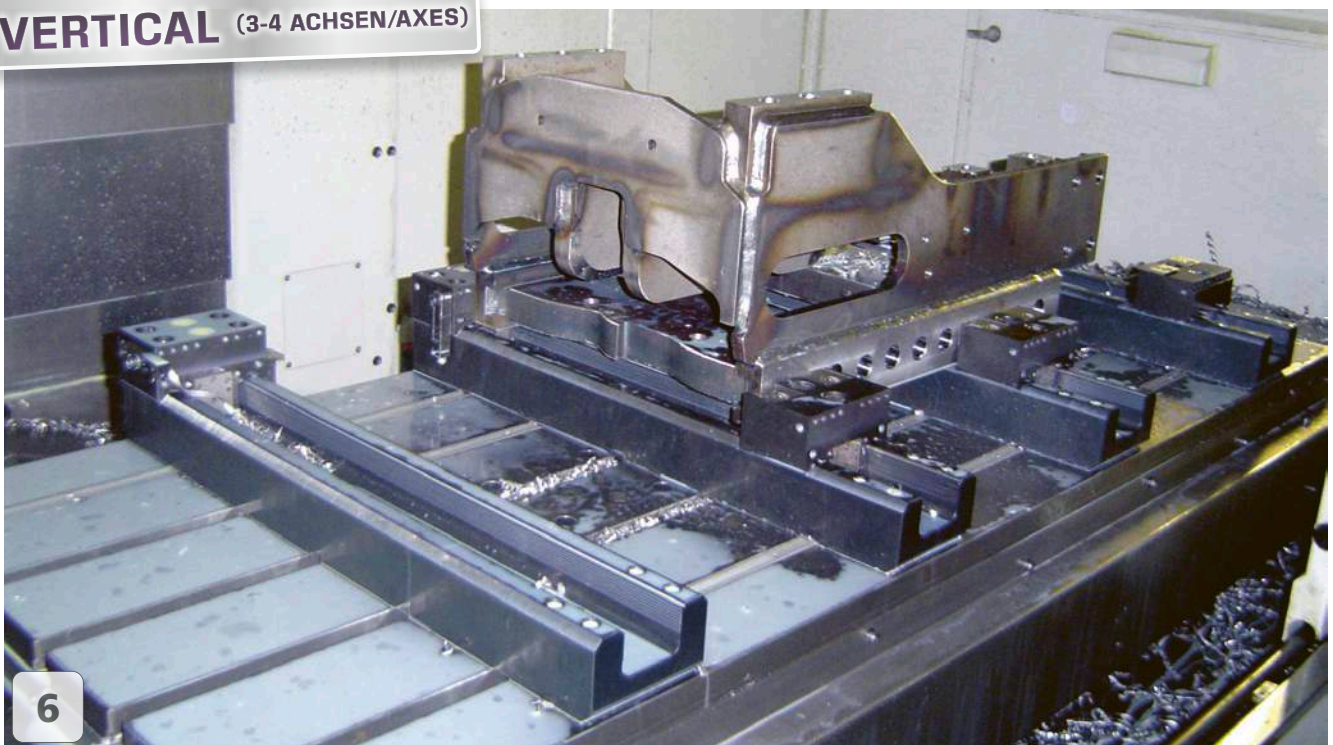

6

Es gibt zusätzlich Apto Clamp Module in angeschrägter Ausführung. Damit kann ein optimaler Zugang zum Werkstück bei der 5-Achsenmaschine gewährleistet werden. Die Spannmodule produzieren bis zu 7000daN (7 Tonnen) Spannkraft und sind für die Schwerzerspannung empfohlen.

We offer Apto Clamp modules in slanted version. That ensures an optimal access to the workpieces on 5-axis machines. The clamping modules produce up to 7000daN (7 tons) clamping force and are recommended for heavy roughing workholding.

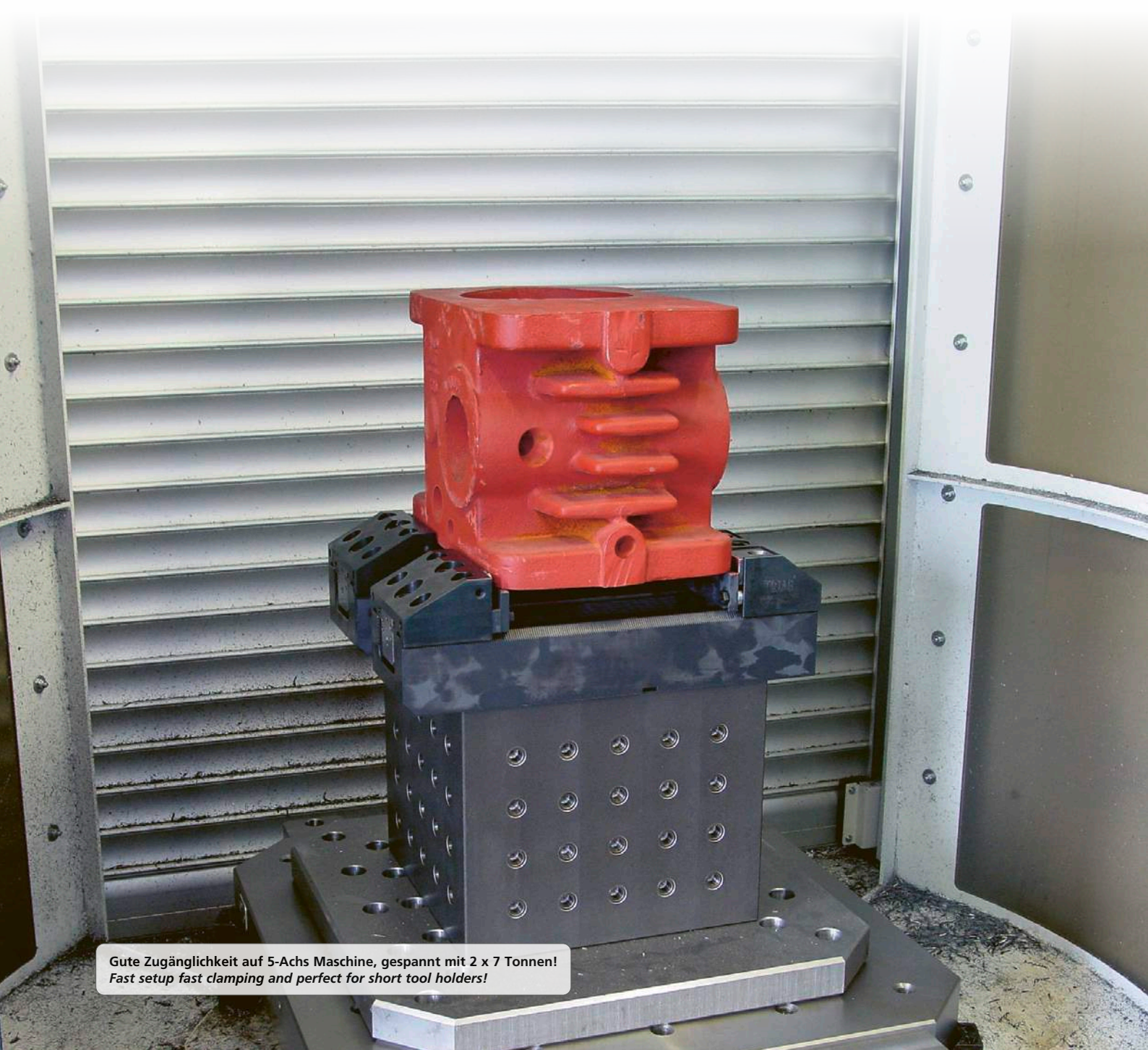

**Gute Zugänglichkeit auf 5-Achs Maschine, gespannt mit 2 x 7 Tonnen!
Fast setup fast clamping and perfect for short tool holders!**

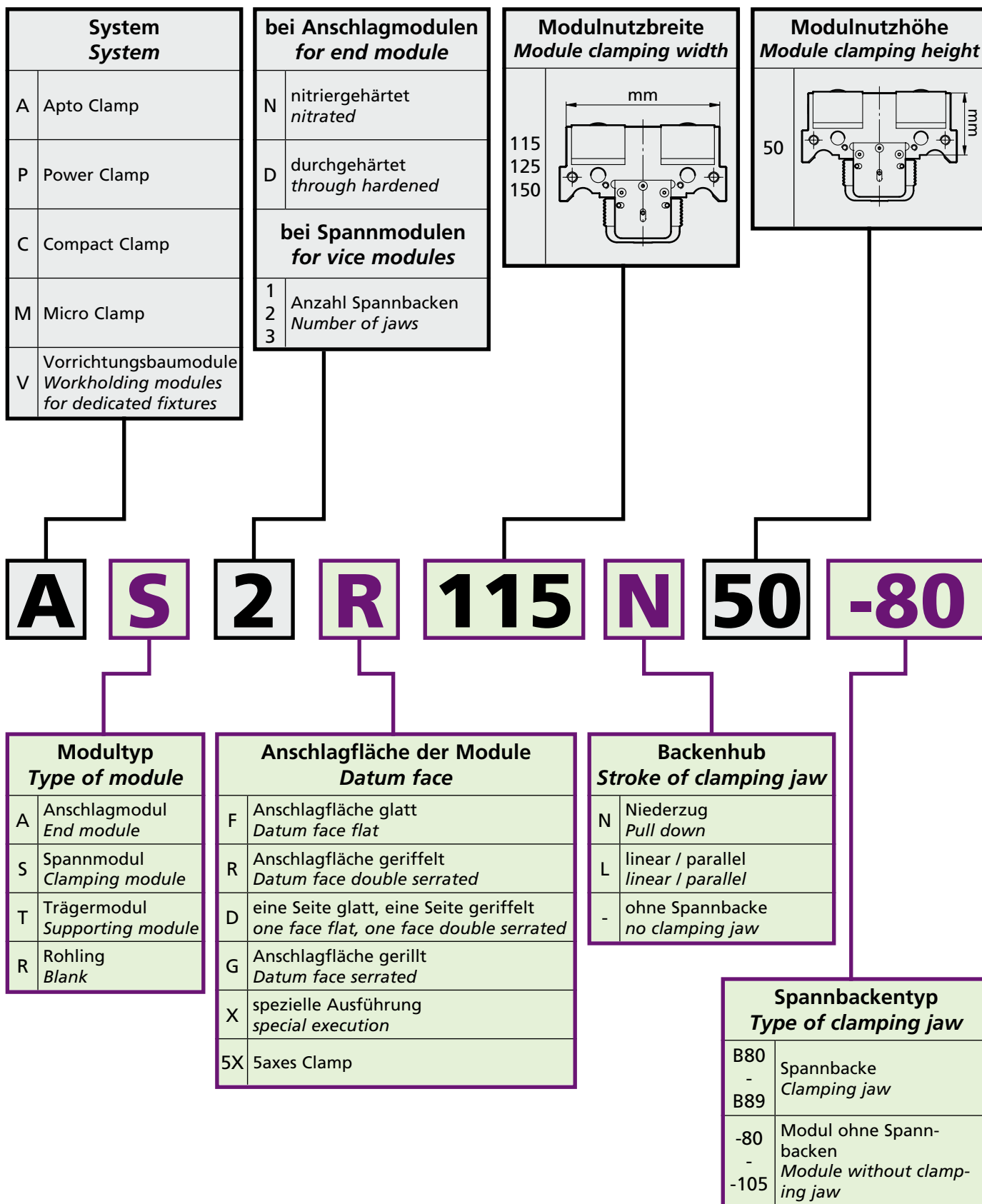

ACB4050400 kg ~18

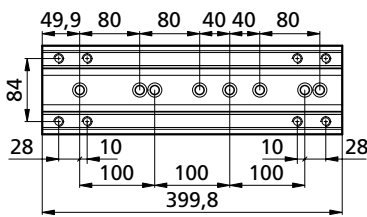

ACB4050700 kg ~31

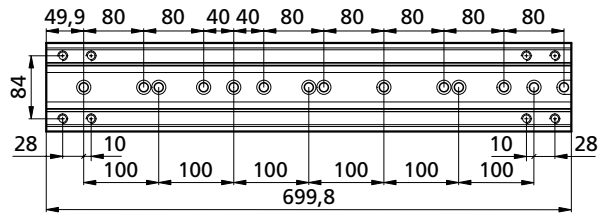

ACB4050450 kg ~20

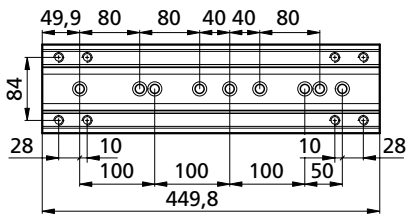

ACB4050750 kg ~33

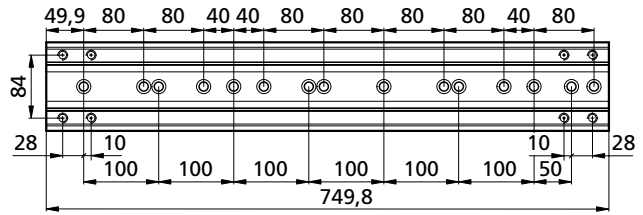

ACB4050500 kg ~22

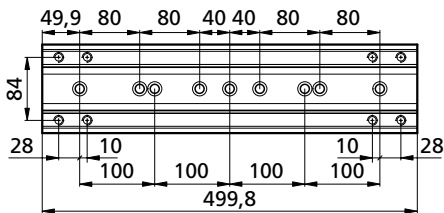

ACB4050800 kg ~35

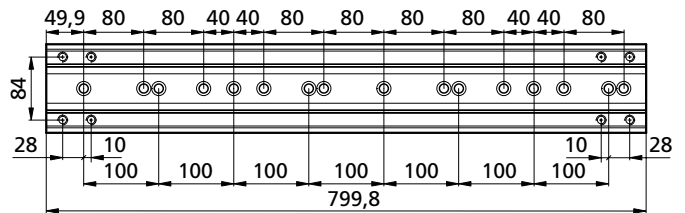

ACB4050550 kg ~24

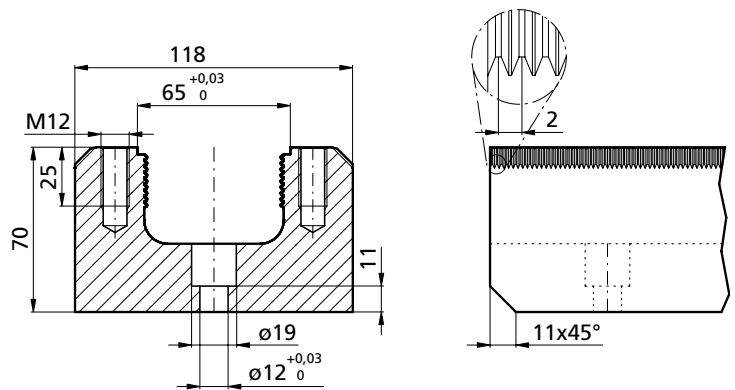
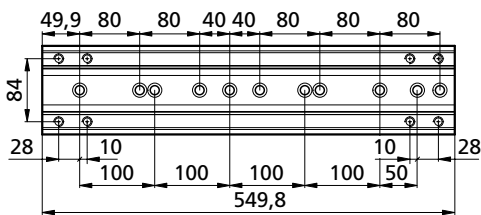

ACB4050600 kg ~26

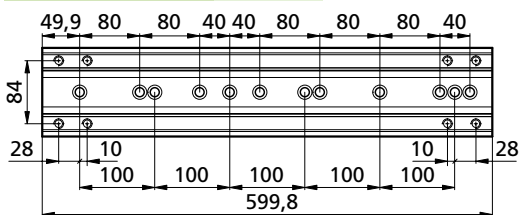

ACB4050650 kg ~29

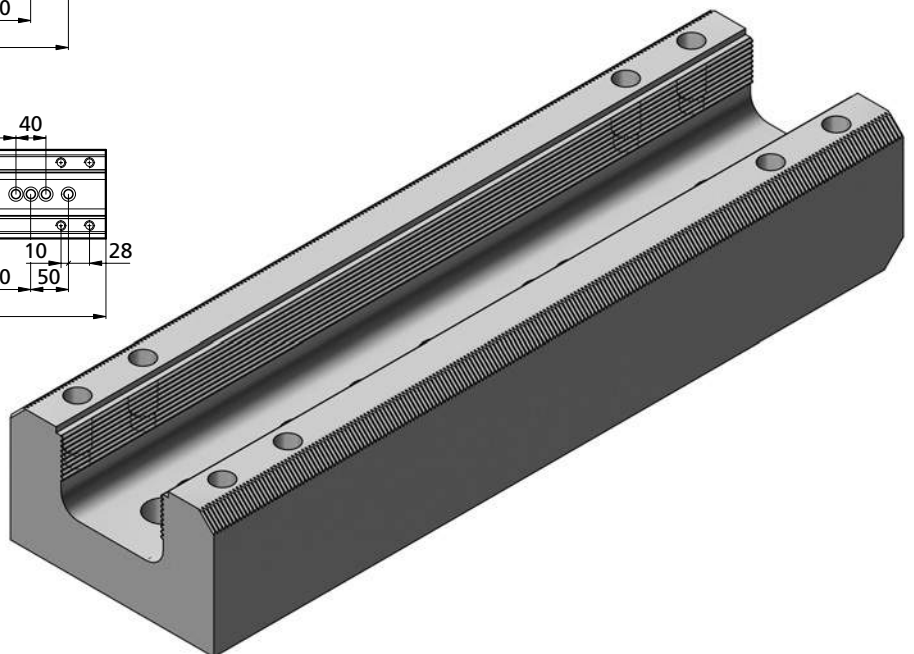
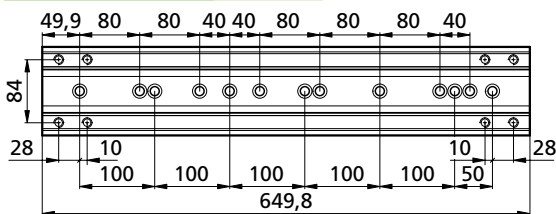

Spannmodule Clamping module

AS2R/F115N50-80
AS25X115N50-80

5axes
aptoCLAMP

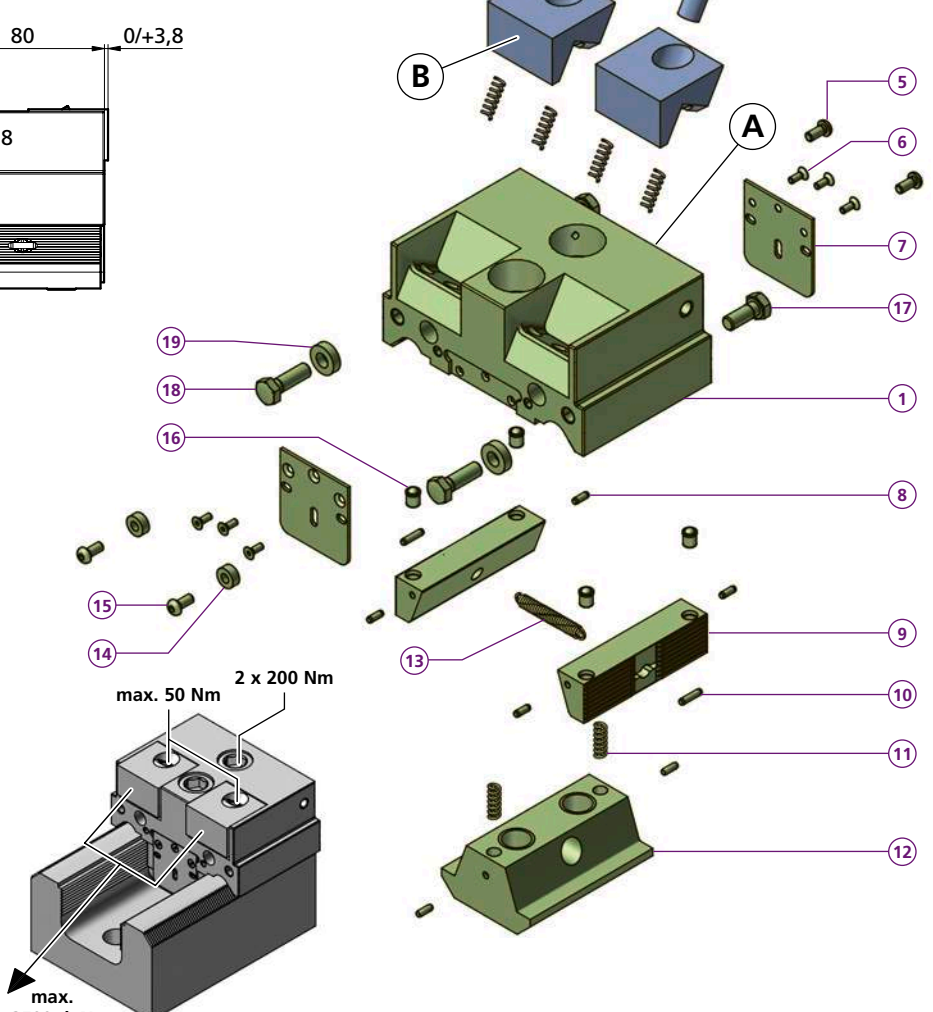
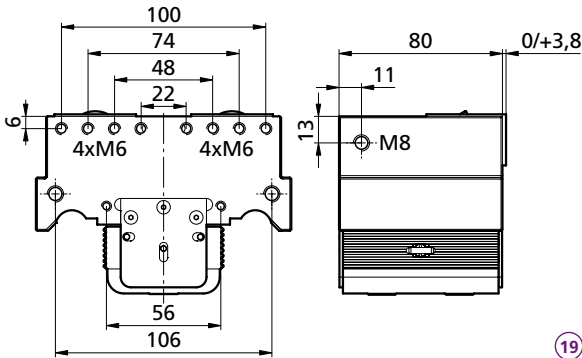
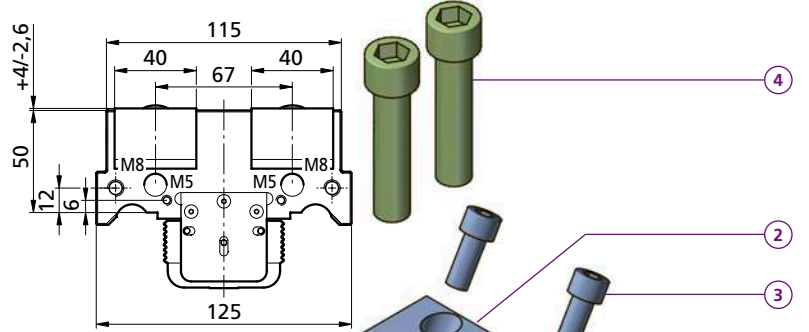
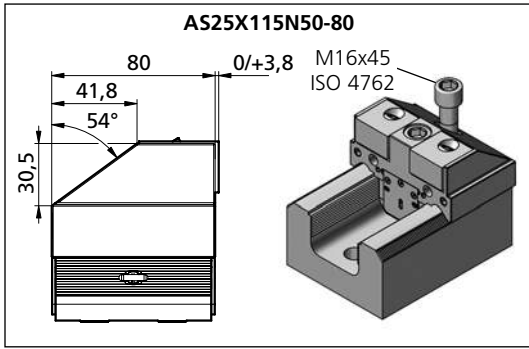

- AS25X115N50-80**
- 1x TF140678
 - 1x M16X45ISO4762
 - 1x M16X70ISO4762
 - 2x M8X20ISO4017
 - 2x ACD005
 - kg ~4,3
- AS2F115N50-80**
- 1x TF140676
- AS2R115N50-80**
- 1x TF140677
 - 2x
 - 2x M10X25ISO4762
 - 2x M16X70ISO4762
 - 2x M5X10ISO7380-1
 - 6x M3X6DIN7991
 - 2x ACBL4243
 - 6x Ø 3x8 VSM 12785
 - 2x ACSP7620
 - 2x Ø 3h 8x12 ISO 2338
 - 6x FED0618
 - 1x ACSK7632M16
 - 1x FED Ø 5,5x39
 - 2x PCD005
 - 2x M5X14ISO7380-1
 - 4x Ø 6-Niro SM1275-3
 - 2x M8X16ISO4017
 - 2x M8X20ISO4017
 - 2x ACD005
 - kg ~4,8

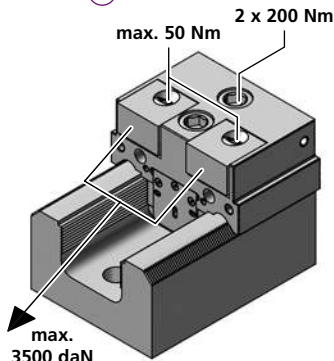

max. 3500 daN

Bestellbeispiel / Ordering example: 1x AS2R115N50-80 & 2x B80

| | B80 | B80N | B81 | B82 | B82L33 | B82HM | B83 | B84 | B89F | B89R |
|----|-------|-----------------|-------|------|--------|-------|-----------------|------|-----------------|-----------------|
| C | 40 | 40 | 40 | 40 | 40 | 40 | 40 | 40 | 40 | 40 |
| H | 25 | 25 | 25 | 25 | 25 | 25 | 25 | 25 | 25 | 25 |
| L | 22 | 22 | 22 | 22,2 | 33 | 22,2 | 22 | 26,3 | 29 | 29 |
| D | 11 | 11 | 11 | 11 | 11 | 11 | 11 | 11 | 11 | 11 |
| e | 15 | 15 | 15 | 15 | 15 | 15 | 15 | 15 | 15 | 15 |
| i | 56HRC | HV700 x0,2mm | 56HRC | * | * | 56HRC | HV700 x0,2mm | * | HV700 x0,2mm | HV700 x0,2mm |
| kg | ~0,2 | ~0,2 | ~0,2 | ~0,2 | ~0,28 | ~0,2 | ~0,2 | ~0,2 | ~0,24 | ~0,24 |

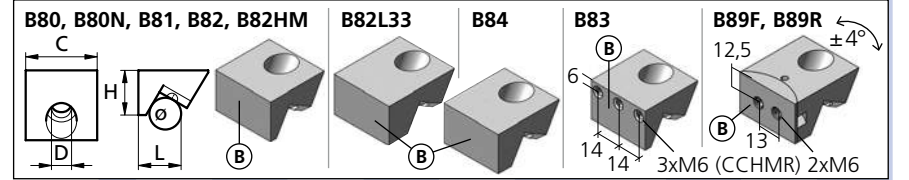

* = weich / soft

HM = Hartmetallbeschichtet / Carbide coated

Separat bestellen / Order separately

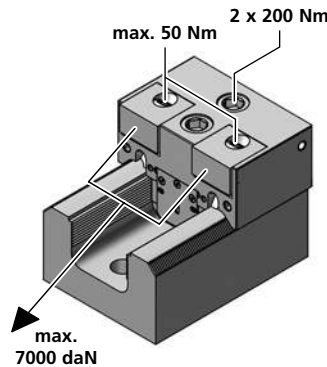
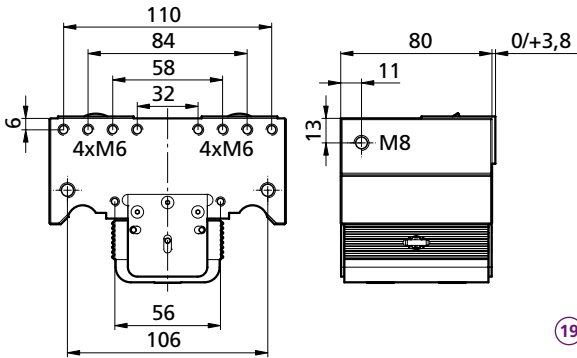
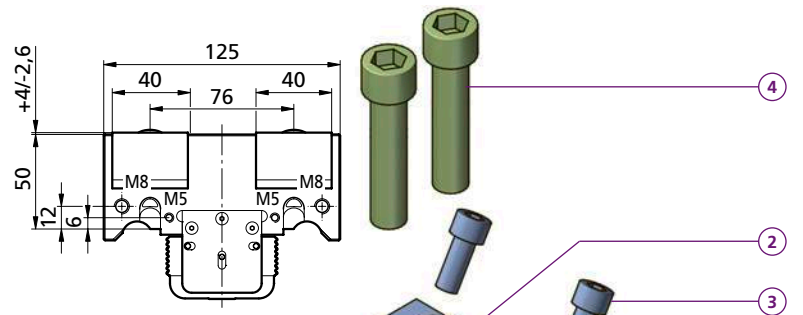
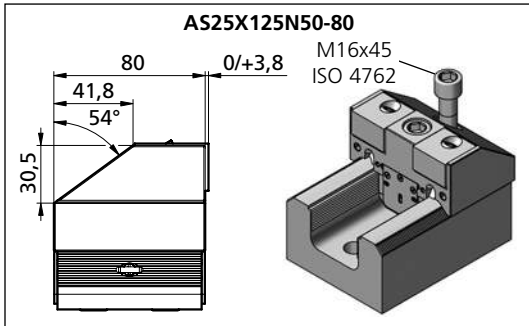

- AS25X125N50-80**
- 1 1x TF140682
 - 4 1x M16X45ISO4762
 - 18 2x M8X20ISO4017
 - 19 2x ACD005
 - kg ~4,3
- AS2F125N50-80**
- 1 1x TF140680
- AS2R125N50-80**
- 1 1x TF140681
 - 2 2x
 - 3 2x M10X25ISO4762
 - 4 2x M16X70ISO4762
 - 5 2x M5X10ISO7380-1
 - 6 6x M3X6DIN7991
 - 7 2x ACBL4243
 - 8 6x Ø 3x8 BN 879
 - 9 2x ACSP7620
 - 10 2x Ø 3h 8x12 ISO 2338
 - 11 6x FED0618
 - 12 1x ACSK7632M16
 - 13 1x FED Ø 5,5x39
 - 14 2x PCD005
 - 15 2x M5X14ISO7380-1
 - 16 4x Ø 6-Niro SM1275-3
 - 17 2x M8X16ISO4017
 - 18 2x M8X20ISO4017
 - 19 2x ACD005
 - kg ~4,9

Bestellbeispiel / Ordering example: 1x AS2R125N50-80 & 2x B80

| | B80 | B80N | B81 | B82 | B82L33 | B82HM | B83 | B84 | B89F | B89R |
|----|-------|-----------------|-------|------|--------|-------|-----------------|------|-----------------|-----------------|
| C | 40 | 40 | 40 | 40 | 40 | 40 | 40 | 40 | 40 | 40 |
| H | 25 | 25 | 25 | 25 | 25 | 25 | 25 | 25 | 25 | 25 |
| L | 22 | 22 | 22 | 22,2 | 33 | 22,2 | 22 | 26,3 | 29 | 29 |
| D | 11 | 11 | 11 | 11 | 11 | 11 | 11 | 11 | 11 | 11 |
| ø | 15 | 15 | 15 | 15 | 15 | 15 | 15 | 15 | 15 | 15 |
| i | 56HRC | HV700 x0,2mm | 56HRC | * | * | 56HRC | HV700 x0,2mm | * | HV700 x0,2mm | HV700 x0,2mm |
| kg | ~0,2 | ~0,2 | ~0,2 | ~0,2 | ~0,28 | ~0,2 | ~0,2 | ~0,2 | ~0,24 | ~0,24 |

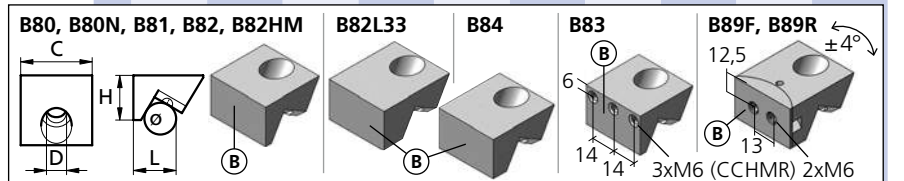

AS2R/F150N50-80
AS25X150N50-80

5axes
aptoCLAMP

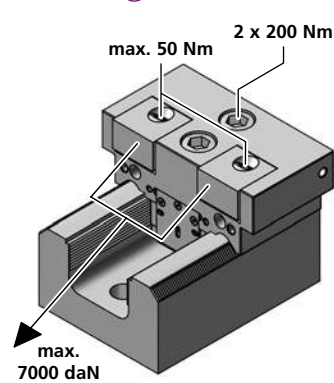
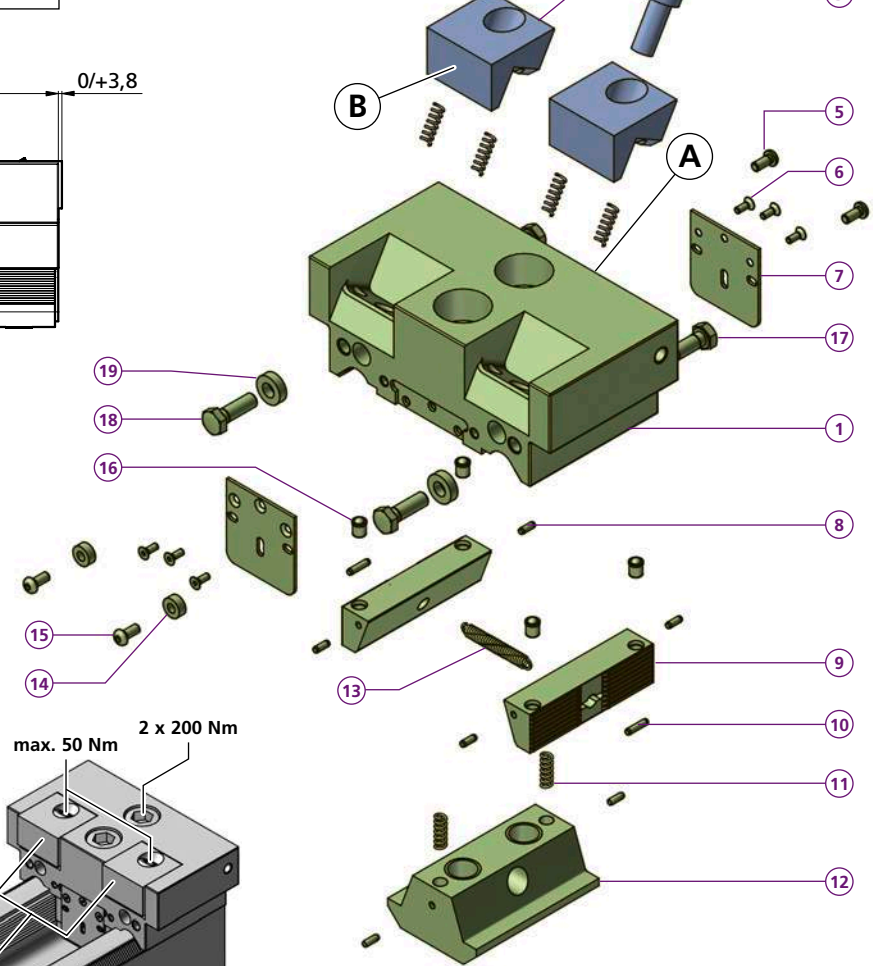
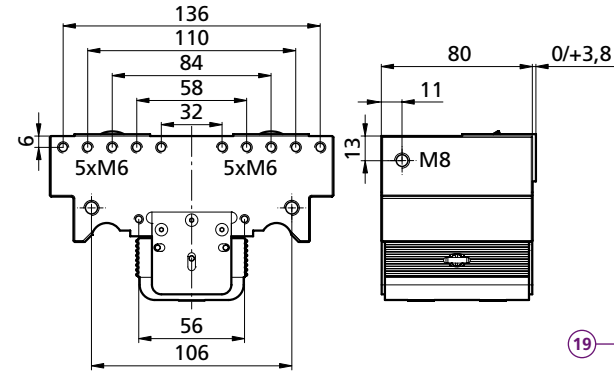
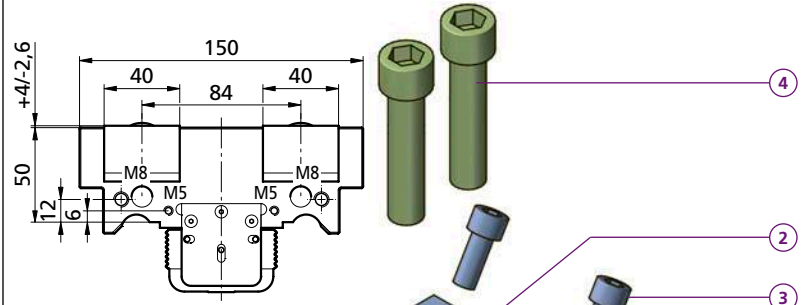
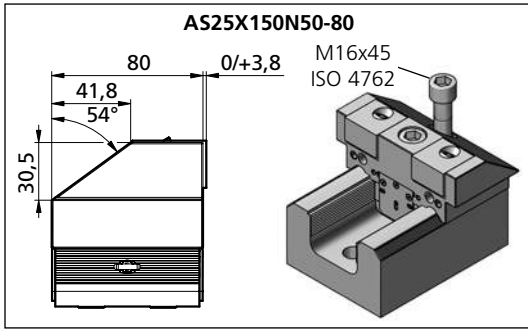

- AS25X150N50-80**
- 1 1x TF140687
 - 4 1x M16X45ISO4762
 - 18 2x M8X20ISO4017
 - 19 2x ACD005
 - kg ~4,7
- AS2F150N50-80**
- 1 1x TF140685
- AS2R150N50-80**
- 1 1x TF140686
 - 2 2x
 - 3 2x M10X25ISO4762
 - 4 2x M16X70ISO4762
 - 5 2x M5X10ISO7380-1
 - 6 6x M3X6DIN7991
 - 7 2x ACBL4243
 - 8 6x Ø 3x8 VSM 12785
 - 9 2x ACSP7620
 - 10 2x Ø 3h 8x12 ISO 2338
 - 11 6x FED0618
 - 12 1x ACSK7632M16
 - 13 1x FED Ø 5,5x39
 - 14 2x PCD005
 - 15 2x M5X14ISO7380-1
 - 16 4x Ø 6-Niro SM1275-3
 - 17 2x M8X16ISO4017
 - 18 2x M8X20ISO4017
 - 19 2x ACD005
 - kg ~5,4

Bestellbeispiel / Ordering example: 1x AS2R150N50-80 & 2x B80

| | B80 | B80N | B81 | B82 | B82L33 | B82HM | B83 | B84 | B89F | B89R |
|----|-------|-----------------|-------|------|--------|-------|-----------------|------|-----------------|-----------------|
| C | 40 | 40 | 40 | 40 | 40 | 40 | 40 | 40 | 40 | 40 |
| H | 25 | 25 | 25 | 25 | 25 | 25 | 25 | 25 | 25 | 25 |
| L | 22 | 22 | 22 | 22,2 | 33 | 22,2 | 22 | 26,3 | 29 | 29 |
| D | 11 | 11 | 11 | 11 | 11 | 11 | 11 | 11 | 11 | 11 |
| ø | 15 | 15 | 15 | 15 | 15 | 15 | 15 | 15 | 15 | 15 |
| i | 56HRC | HV700 x0,2mm | 56HRC | * | * | 56HRC | HV700 x0,2mm | * | HV700 x0,2mm | HV700 x0,2mm |
| kg | ~0,2 | ~0,2 | ~0,2 | ~0,2 | ~0,28 | ~0,2 | ~0,2 | ~0,2 | ~0,24 | ~0,24 |

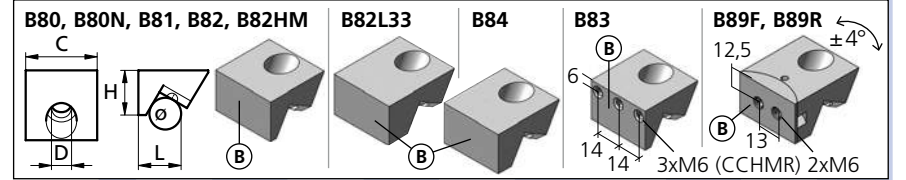

* = weich / soft

HM = Hartmetallbeschichtet / Carbide coated

Separat bestellen / Order separately

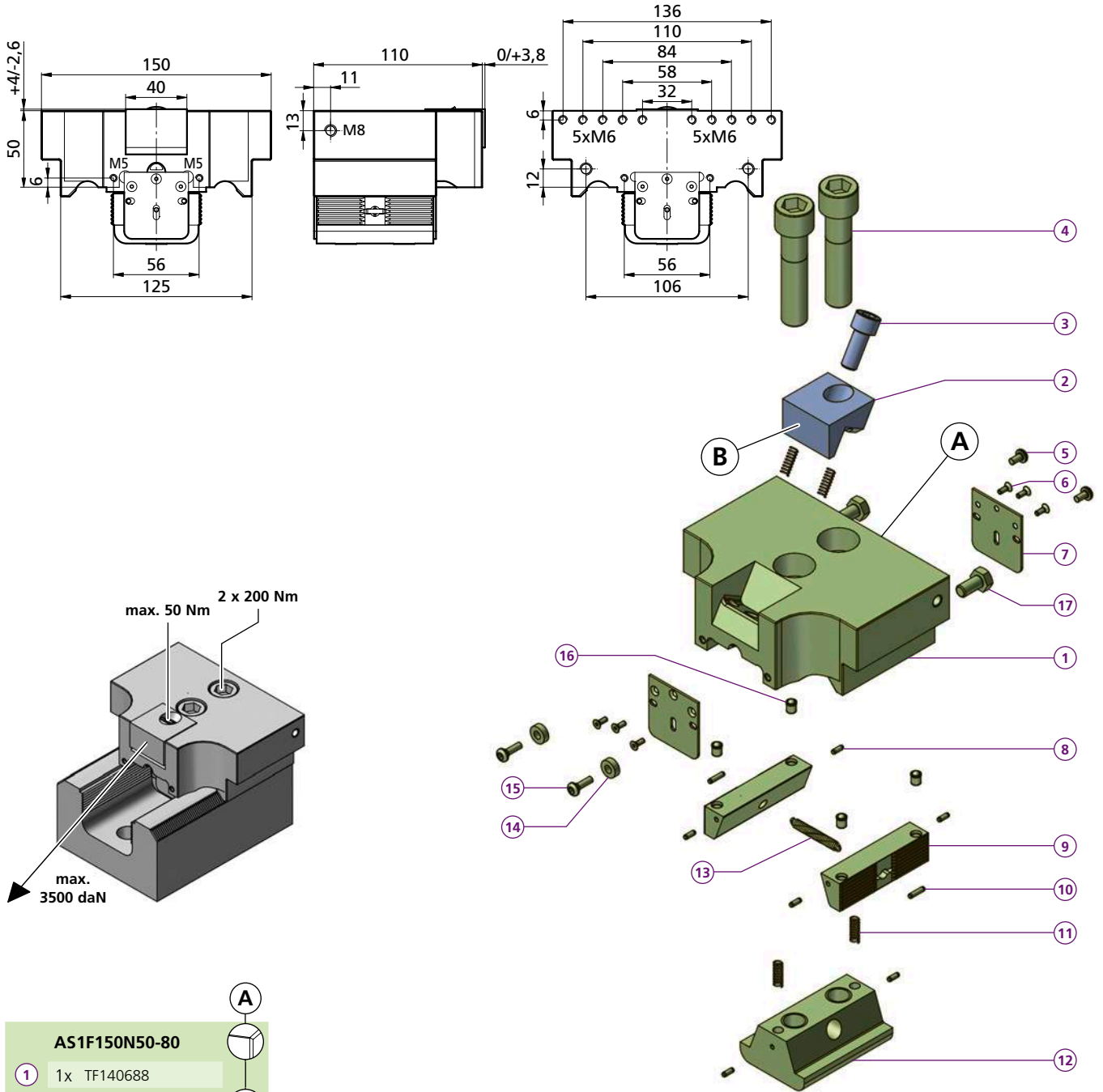

- AS1F150N50-80**
- 1x TF140688
- AS1R150N50-80**
- 1x TF140689
- 2x
- 1x **M10X25ISO4762**
- 2x **M16X70ISO4762**
- 2x **M5X10ISO7380-1**
- 6x M3X6DIN7991
- 2x ACBL4243
- 6x Ø 3x8 VSM 12785
- 2x ACSP7620
- 2x Ø 3h 8x12 ISO 2338
- 4x **FED0618**
- 1x ACSK7632M16
- 1x FED Ø 5,5x39
- 2x **PCD005**
- 2x **M5X14ISO7380-1**
- 4x Ø 6-Niro SM1275-3
- 2x M8X16ISO4017
- kg ~6,6

Bestellbeispiel / Ordering example: 1x AS1R150N50-80 & 1x B80

| | B80 | B80N | B81 | B82 | B82L33 | B82HM | B83 | B84 | B89F | B89R |
|-----------|-------|-----------------|-------|------|--------|-------|-----------------|------|-----------------|-----------------|
| C | 40 | 40 | 40 | 40 | 40 | 40 | 40 | 40 | 40 | 40 |
| H | 25 | 25 | 25 | 25 | 25 | 25 | 25 | 25 | 25 | 25 |
| L | 22 | 22 | 22 | 22,2 | 33 | 22,2 | 22 | 26,3 | 29 | 29 |
| D | 11 | 11 | 11 | 11 | 11 | 11 | 11 | 11 | 11 | 11 |
| e | 15 | 15 | 15 | 15 | 15 | 15 | 15 | 15 | 15 | 15 |
| i | 56HRC | HV700 x0,2mm | 56HRC | * | * | 56HRC | HV700 x0,2mm | * | HV700 x0,2mm | HV700 x0,2mm |
| kg | ~0,2 | ~0,2 | ~0,2 | ~0,2 | ~0,28 | ~0,2 | ~0,2 | ~0,2 | ~0,24 | ~0,24 |

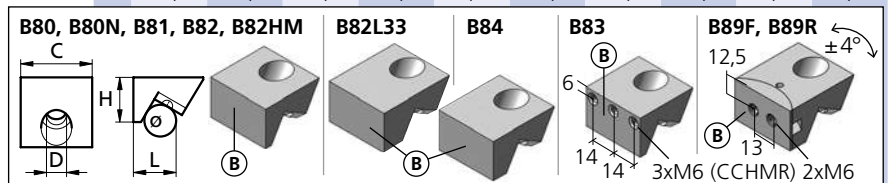

AS2X125L50-105 AS25X125L50-105

5axes aptoCLAMP

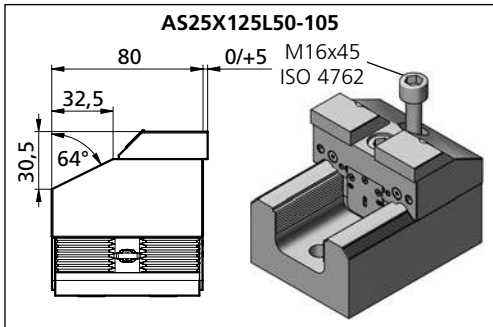
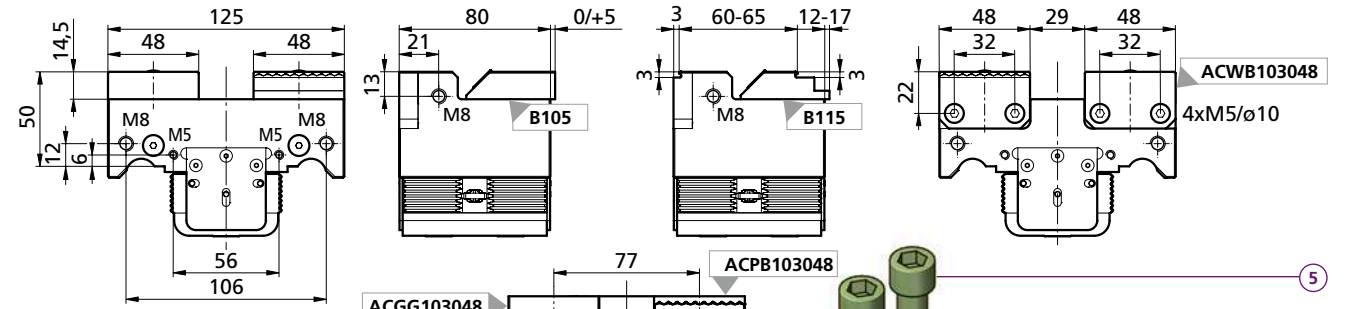

| AS25X125L50-105 | |
|-----------------|----------------------------|
| 1 | 1x TF140683 |
| 4 | 1x M16X45ISO4762 |
| 19 | 1x M16X55ISO4762 |
| 19 | 2x M8X20ISO4017 |
| 20 | 2x ACD005 |
| kg | ~4,3 |
| AS2X125L50-105 | |
| 1 | 1x TF140684 |
| 2 | 2x powerCLAMP p. 85 |
| 3 | 2x M8X30ISO4762 |
| 4 | 2x PCUSR 14 |
| 5 | 2x M16X55ISO4762 |
| 6 | 2x M5X10ISO7380-1 |
| 7 | 6x M3X6DIN7991 |
| 8 | 2x ACBL4243 |
| 9 | 6x Ø 3x8 VSM 12785 |
| 10 | 2x ACSP7620 |
| 11 | 2x Ø 3h 8x12 ISO 2338 |
| 12 | 6x FED0618 |
| 13 | 1x ACSI7632M16 |
| 14 | 1x FED Ø 5,5x39 |
| 15 | 2x PCD005 |
| 16 | 2x M5X14ISO7380-1 |
| 17 | 4x Ø 6-Niro SM1275-3 |
| 18 | 2x M8X16ISO4017 |
| 19 | 2x M8X20ISO4017 |
| 20 | 2x ACD005 |
| 21 | 2x ACGGB103048 |
| 22 | 4x M5X20ISO7380-1 |
| 23 | 4x Ø 5,2 ISO 4247 |
| 24 | 2x M5x10 DIN 7991 |
| 25 | 2x PCKMR45M8 |
| 26 | 4x d=6 DIN 5401 |
| 27 | 2x TS120001 |
| kg | ~4,5 |

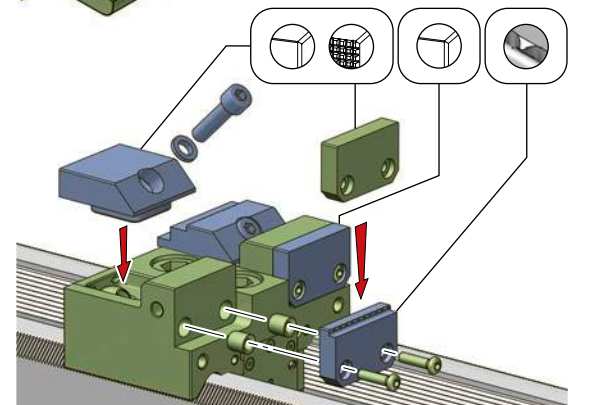
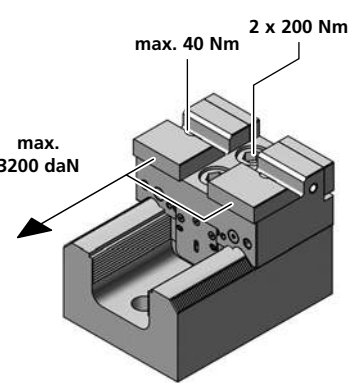
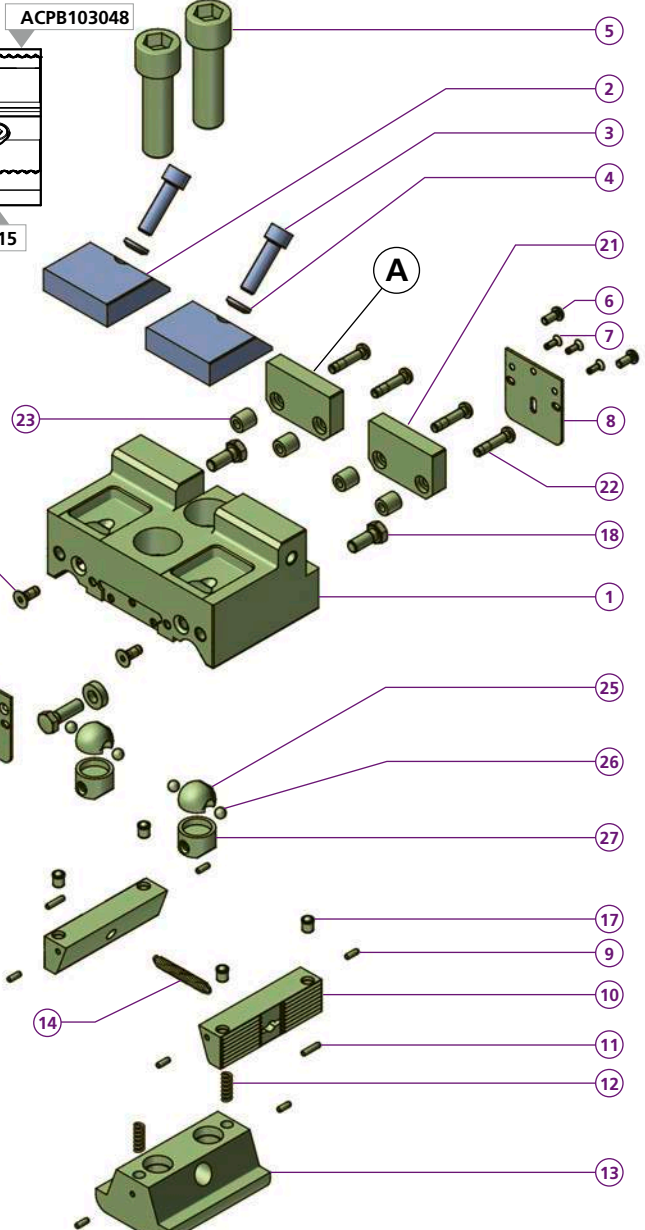
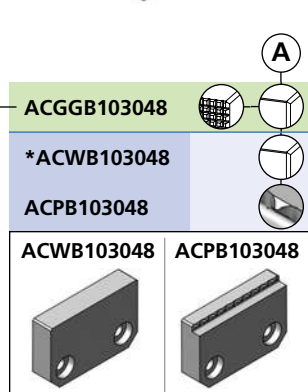
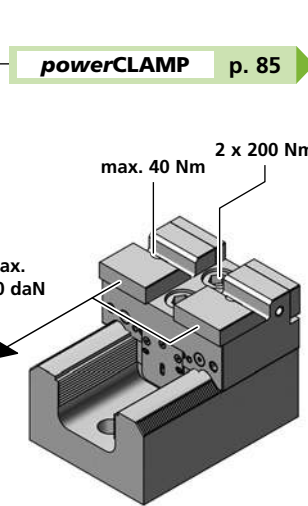
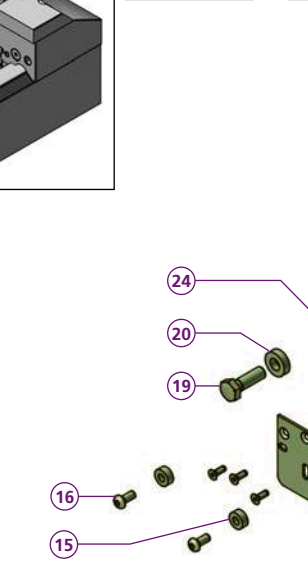
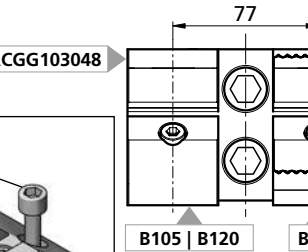

Bestellbeispiel / Ordering example:
1x AS2X125L50-150 & 2x B105 & 2x ACGGB103048

* = weich / soft

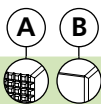
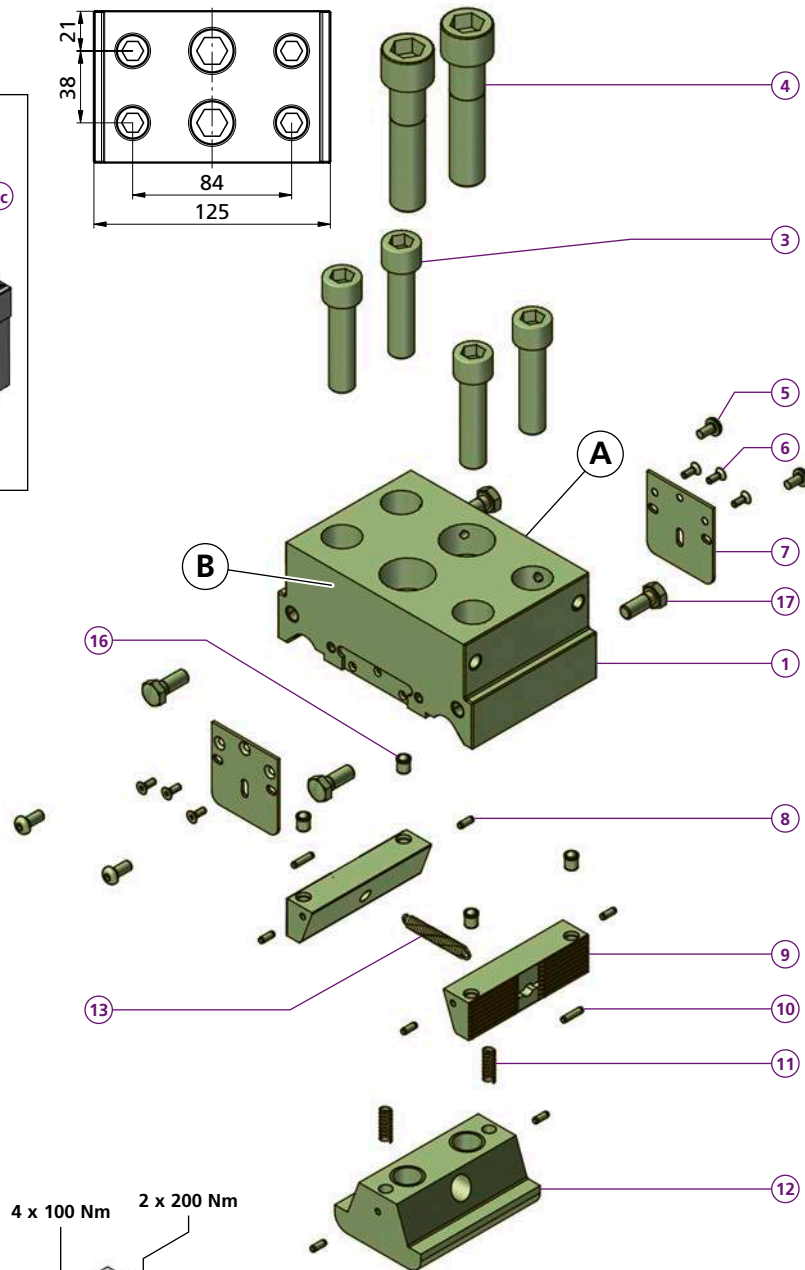
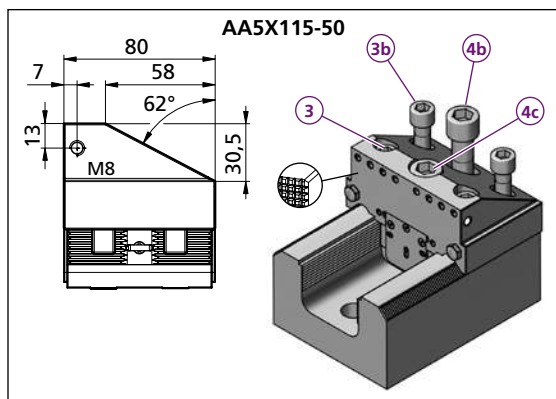
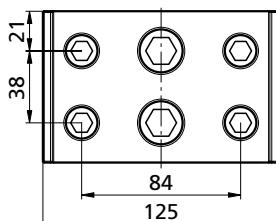
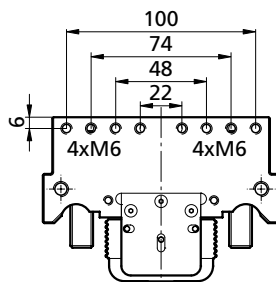
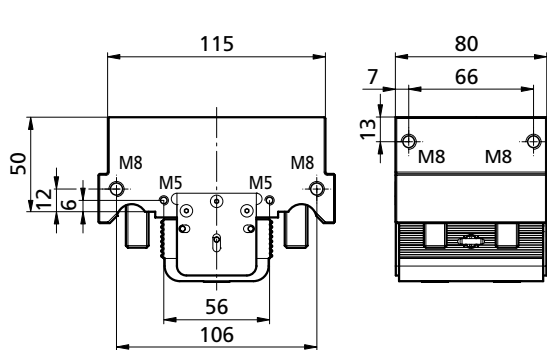

AAND115-50

- 1x TF140690
 - 4x **M12X50ISO4762**
 - 2x **M16X70ISO4762**
 - 4x **M5X10ISO7380-1**
 - 6x M3X6DIN7991
 - 2x ACBL4243
 - 6x \varnothing 3x8 VSM 12785
 - 2x ACS P7620
 - 2x \varnothing 3h 8x12 ISO 2338
 - 2x **FED0618**
 - 1x ACSK7632M16
 - 1x FED \varnothing 5,5x39
 - 4x \varnothing 6-Niro SM1275-3
 - 4x M8X16ISO4017
- kg ~4,7



AA5X115-50

- 1x TF140691
 - 2x **M12X50ISO4762**
 - 2x **M12X30ISO4762**
 - 1x **M16X65ISO4762**
 - 1x **M16X45ISO4762**
 - 2x **M5X10ISO7380-1**
 - 2x M8X16ISO4017
- kg ~4,6

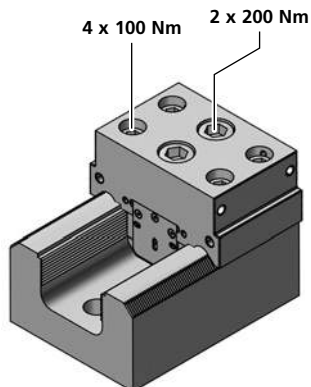

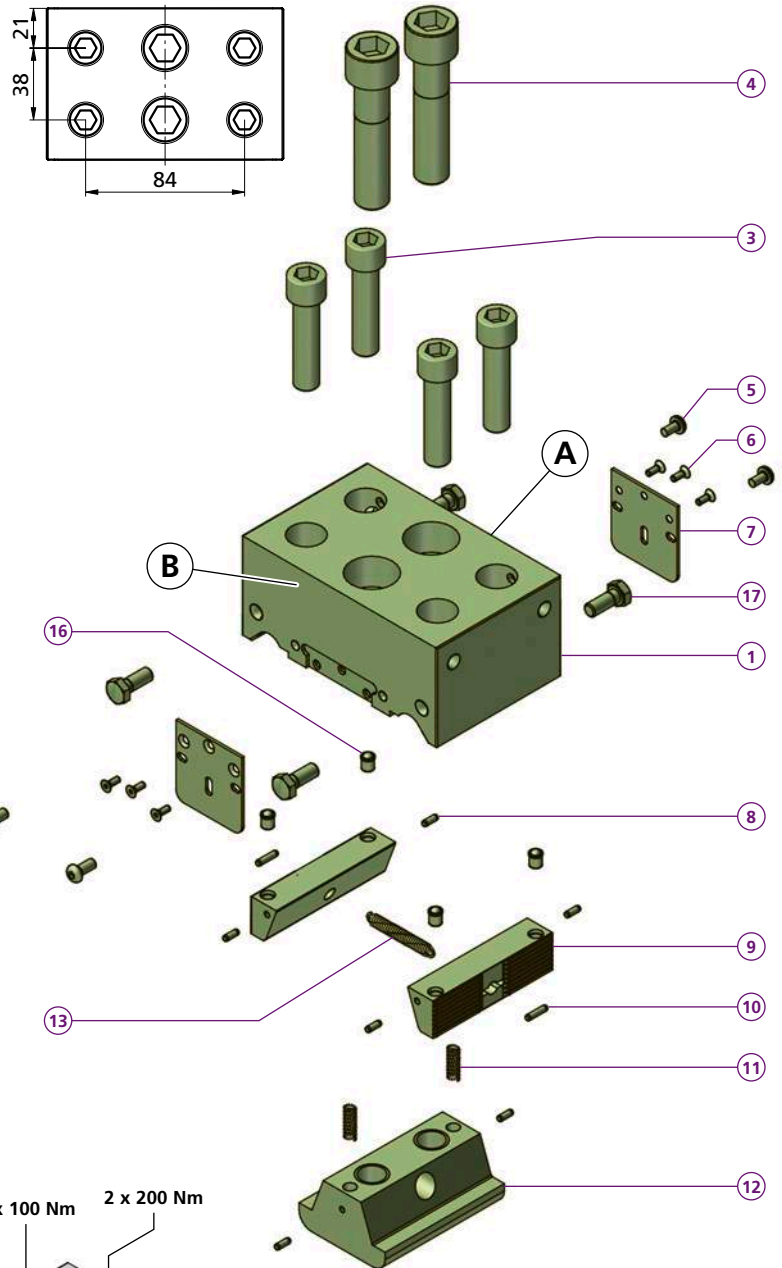
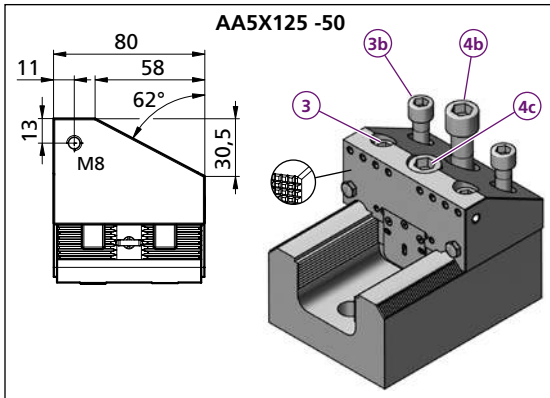
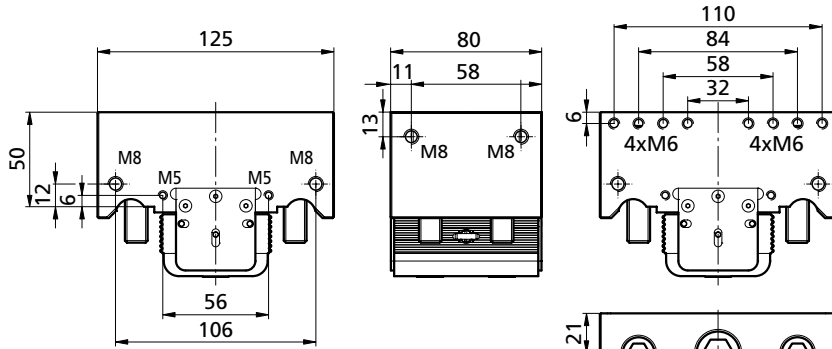

| AAND125-50 | |
|------------|-----------------------|
| 1 | 1x TF140692 |
| 3 | 4x M12X50ISO4762 |
| 4 | 2x M16X70ISO4762 |
| 5 | 4x M5X10ISO7380-1 |
| 6 | 6x M3X6DIN7991 |
| 7 | 2x ACBL4243 |
| 8 | 6x Ø 3x8 VSM 12785 |
| 9 | 2x ACSF7620 |
| 10 | 2x Ø 3h 8x12 ISO 2338 |
| 11 | 2x FED0618 |
| 12 | 1x ACSK7632M16 |
| 13 | 1x FED Ø 5,5x39 |
| 16 | 4x Ø 6-Niro SM1275-3 |
| 17 | 4x M8X16ISO4017 |
| kg | ~4,8 |

| AA5X125-50 | |
|------------|-------------------|
| 1 | 1x TF140693 |
| 3 | 2x M12X50ISO4762 |
| 3b | 2x M12X30ISO4762 |
| 4c | 1x M16X65ISO4762 |
| 4b | 1x M16X45ISO4762 |
| 5 | 2x M5X10ISO7380-1 |
| 17 | 2x M8X16ISO4017 |
| kg | ~4,6 |

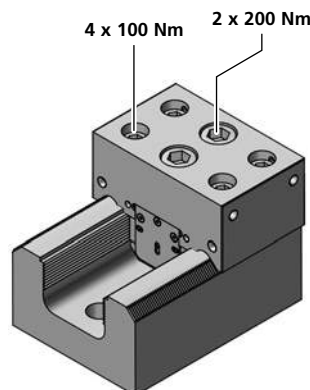

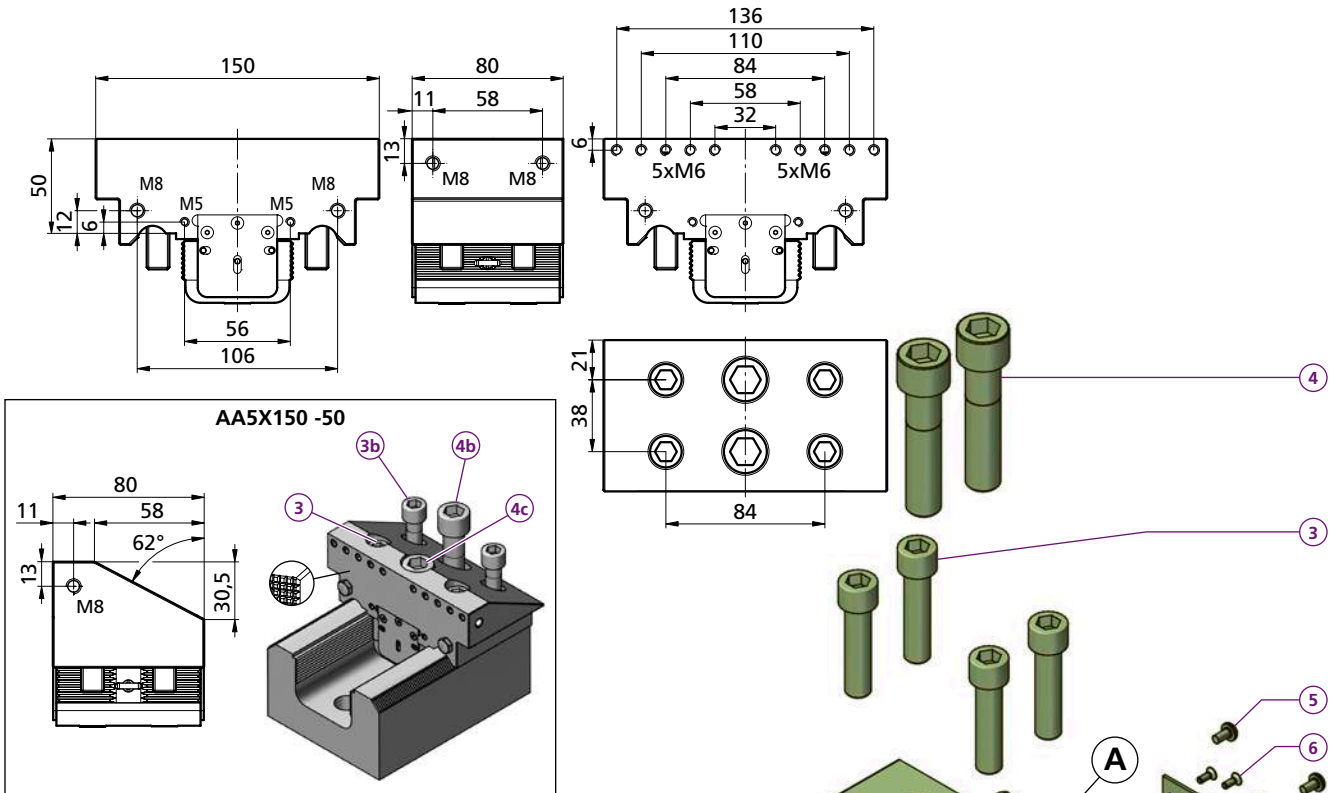

- AAND150-50**
- 1x TF140695
 - 4x M12X50ISO4762
 - 2x M16X70ISO4762
 - 4x M5X10ISO7380-1
 - 6x M3X6DIN7991
 - 2x ACBL4243
 - 6x Ø 3x8 VSM 12785
 - 2x ACS P7620
 - 2x Ø 3h 8x12 ISO 2338
 - 2x FED0618
 - 1x ACSK7632M16
 - 1x FED Ø 5,5x39
 - 4x Ø 6-Niro SM1275-3
 - 4x M8X16ISO4017
- kg ~5,2

- AA5X150-50**
- 1x TF140696
 - 2x M12X50ISO4762
 - 2x M12X30ISO4762
 - 1x M16X65ISO4762
 - 1x M16X45ISO4762
 - 2x M5X10ISO7380-1
 - 2x M8X16ISO4017
- kg ~5,0

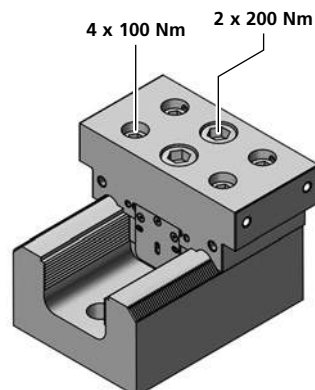

AA5X125-50VB

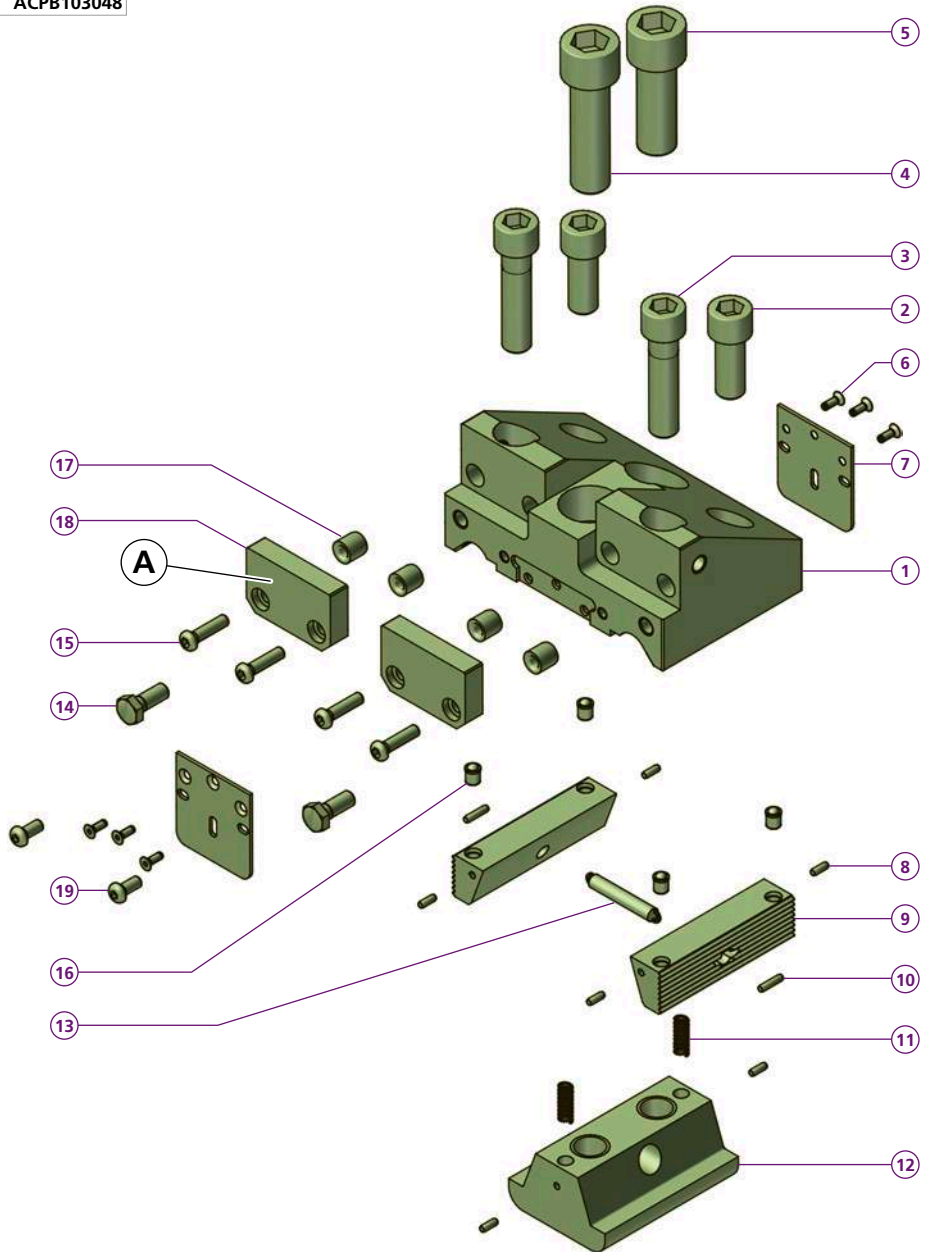
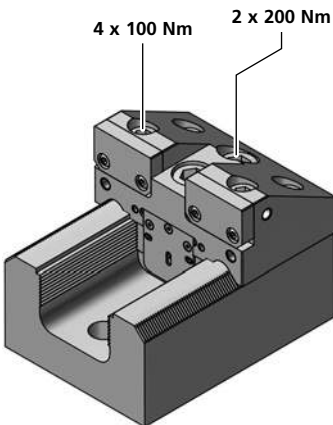
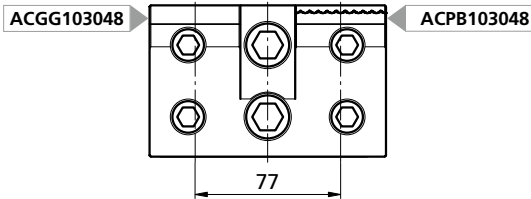
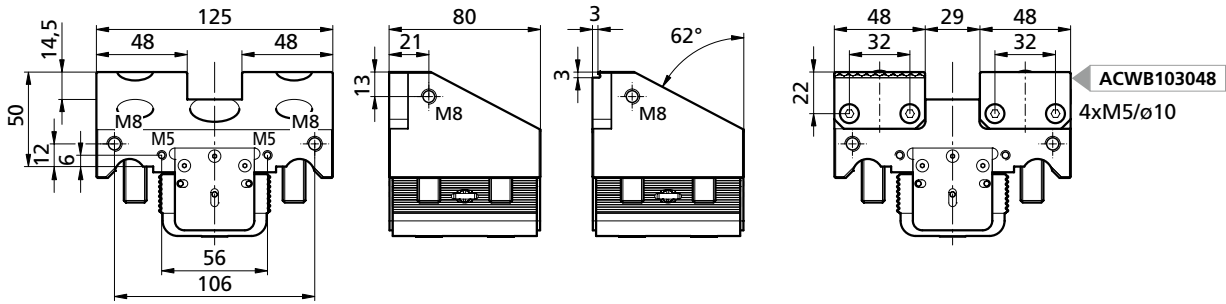

| AA5X125-50VB | |
|--------------|-----------------------|
| 1 | 1x TF140694 |
| 2 | 2x M12X30ISO4762 |
| 3 | 2x M12X50ISO4762 |
| 4 | 1x M16X55ISO4762 |
| 5 | 1x M16X45ISO4762 |
| 6 | 6x M3X6DIN7991 |
| 7 | 2x ACBL4243 |
| 8 | 6x Ø 3x8 VSM 12785 |
| 9 | 2x ACSF7620 |
| 10 | 2x Ø 3h 8x12 ISO 2338 |
| 11 | 2x FED0618 |
| 12 | 1x ACSK7632M16 |
| 13 | 1x FED Ø 5,5x39 |
| 14 | 2x M8X16ISO4017 |
| 15 | 4x M5X20ISO7380-1 |
| 16 | 4x Ø 6-Niro SM1275-3 |
| 17 | 4x 5,2x10x10 DIN179-A |
| 18 | 2x |
| 19 | 2x M5X10ISO7380-1 |
| kg | ~4,5 |

| | |
|-------------|--|
| ACGGB103048 | |
| *ACWB103048 | |
| ACPB103048 | |
| ACWB103048 | |
| ACPB103048 | |

Bestellbeispiel / Ordering example:
1x AA5X125-50VB & 2x ACGGB103048

Separat bestellen / Order separately

**Parallelunterlage
Steel parallels**

| 124mm | B | H | kg |
|----------|-----|----|--------|
| ACU21124 | 124 | 21 | ~0,138 |
| ACU36124 | 124 | 36 | ~0,250 |
| ACU41124 | 124 | 41 | ~0,294 |
| ACU46124 | 124 | 46 | ~0,328 |

| 94mm | B | H | kg |
|----------|----|----|-------|
| PCU14093 | 93 | 14 | ~0,04 |
| PCU20093 | 93 | 20 | ~0,06 |
| PCU24093 | 93 | 24 | ~0,07 |
| PCU29093 | 93 | 29 | ~0,09 |
| PCU31093 | 93 | 31 | ~0,09 |
| PCU34093 | 93 | 34 | ~0,10 |
| PCU39093 | 93 | 39 | ~0,11 |
| PCU44093 | 93 | 44 | ~0,12 |
| PCU46093 | 93 | 46 | ~0,14 |

| 125mm | B | H | kg |
|----------|-----|----|-------|
| PCU20124 | 124 | 20 | ~0,08 |
| PCU24124 | 124 | 24 | ~0,09 |
| PCU29124 | 124 | 29 | ~0,11 |
| PCU31124 | 124 | 31 | ~0,12 |
| PCU34124 | 124 | 34 | ~0,13 |
| PCU39124 | 124 | 39 | ~0,15 |
| PCU44124 | 124 | 44 | ~0,17 |

**Universalnut
Universal nut**

ACES6540

- ① 1x ACZS6540
- ② 1x ACEL6540
- ③ 1x M12X30DIN7984
- ④ 2x SM1275-1KSM8

kg ~ 0,67

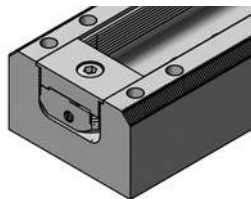

ACES10240H07

- ① 1x ACZS6540
- ② 1x ACEL6540-07102
- ③ 1x M12X30DIN7984
- ④ 2x SM1275-1KSM8

kg ~ 0,88

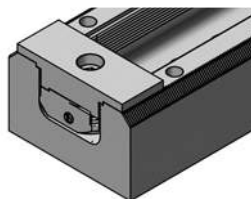

ACES10040H25W

- ① 1x ACZS6540
- ② 1x ACEL10040H25W
- ③ 1x M12X30DIN7984
- ④ 2x SM1275-1KSM8

kg ~ 1,42

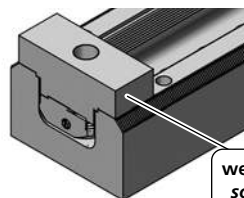

weich
soft 1.2312

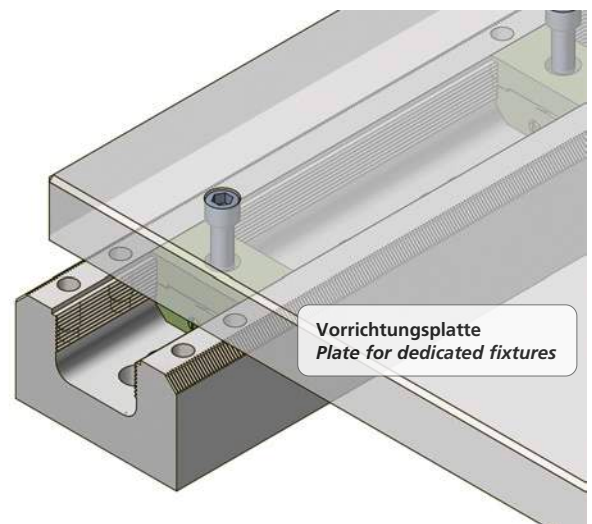

Bestellbeispiel / Ordering example: **ACES6540**

Separat bestellen / Order separately

Universal - Unterlagenhalter

Universal holder for steel parallels

aptoCLAMP

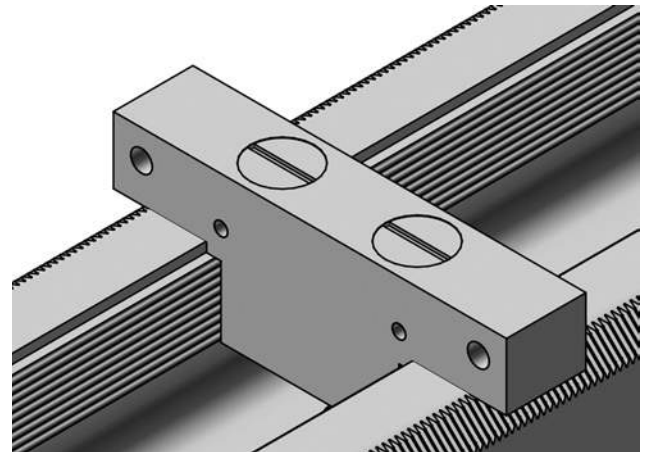
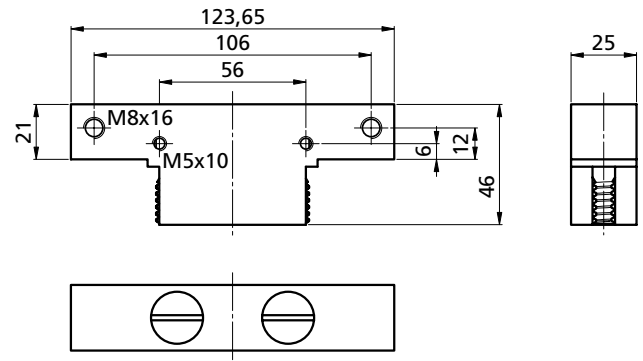
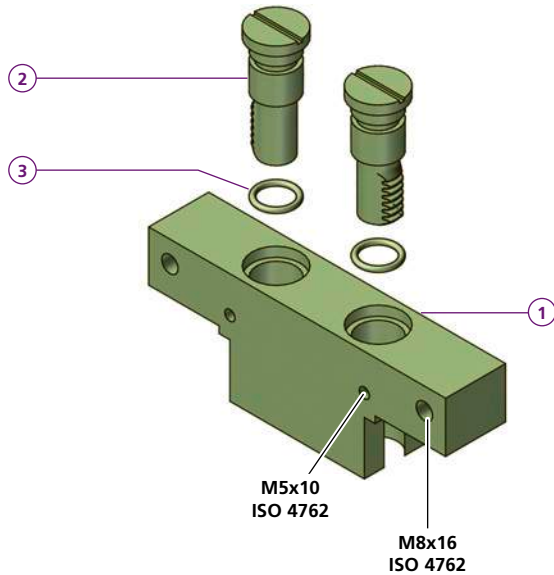

Bestellbeispiel / Ordering example: **ACUH21-124**

ACUH21-124

- ① 1x TW090086-02
 - ② 2x ACBS1646
 - ③ 2x OR Ø 12X2
- kg ~ 0,74

weiche Backe soft jaw

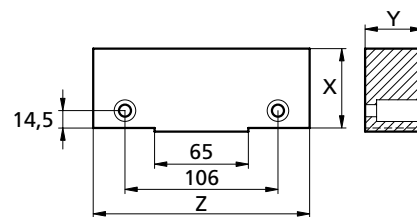
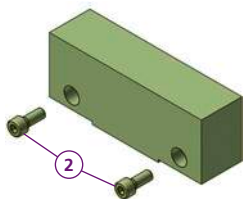

| | | X | Y | Z | kg |
|------------|--------------|----|----|-----|--------|
| AC1505520W | ② | 55 | 20 | 150 | ~ 1,28 |
| AC1505540W | M8X20ISO4762 | 55 | 40 | 150 | ~ 2,55 |

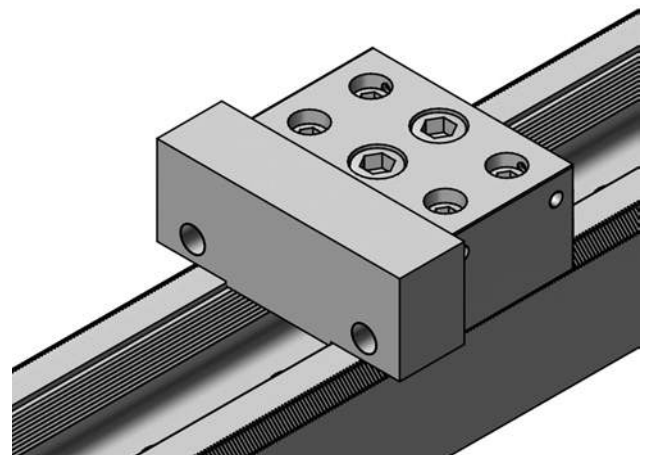

Bestellbeispiel / Ordering example: **AC1505520W**

| | | | |
|----------------------------|---|---|---|
| Kunde Customer | | | |
| Maschine Machine | | Werkstoff, Halbzeug, Rohteil-Nr., Modell- oder Gesenk-Nr. Raw material, blank or casting-Nr. | |
| X | Verfahrweg Traverse | | mm |
| Y | Verfahrweg Traverse | | mm |
| Z | Verfahrweg Traverse | | mm |
| Z min. | kleinster Abstand von der Tischoberfläche zur Spindelnase smallest distance from table surface to spindle gauge line | | mm |
| Z max. | grösster Abstand von der Tischoberfläche zur Spindelnase greatest distance from table surface to spindle gauge line | | mm |
| Ø Spindel Spindle | Spindeldurchmesser Spindle diameter | | mm |
| kg max. | Maximale Tischbelastung Maximum loading capacity | | kg |
| A x B | Tischgrösse Size of the table | | mm |
| E | T-Nuten Grösse T-slots size | | mm |
| C | T-Nuten Abstand T-slots distance | | mm |
| Rasterplatte Grid plate | H Raster Abstand Grid distance | mm | G Gewinde & Passungsdurchmesser Ø Thread & Precision Bohre |
| | Anzahl Werkstücke pro Los Number of workpieces per lot | | Stück Pieces |

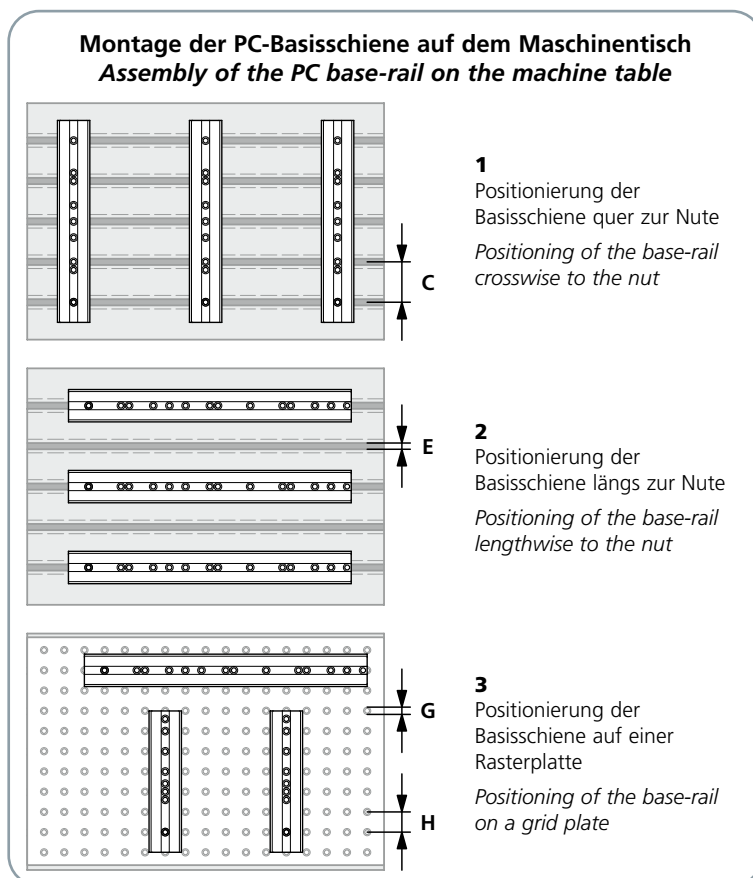
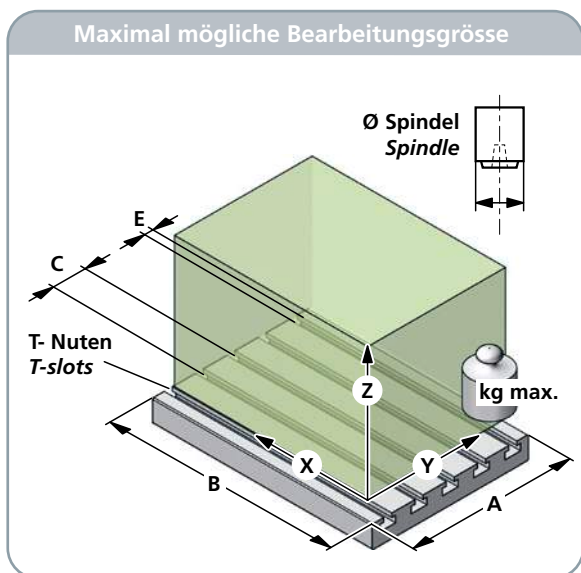



Bitte Werkstückzeichnung beilegen und Bearbeitungsfolge markieren
Enclose drawing of workpiece and mark processing sequence, please

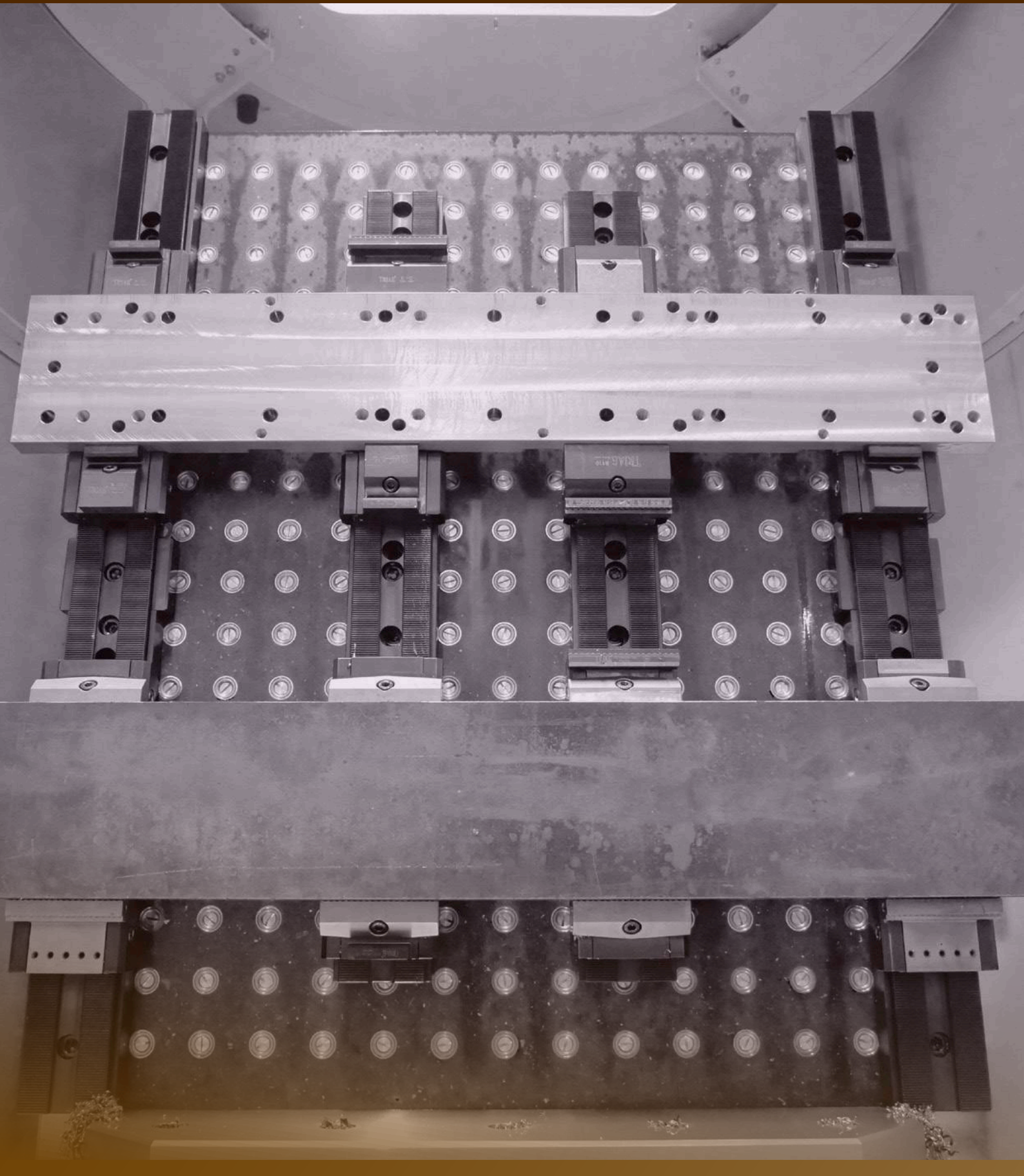

tripoxyMINERAL



 **Einleitung | Introduction** 238 - 243

 **Bedienungsanleitung | Operating manual** 244

Reparaturanleitung für Mineralguss | How to repair epoxy mineral casting 245

Anwendungsbeispiele | Examples of application 247 - 248

Mineralguss | Epoxy mineral 251 - 270

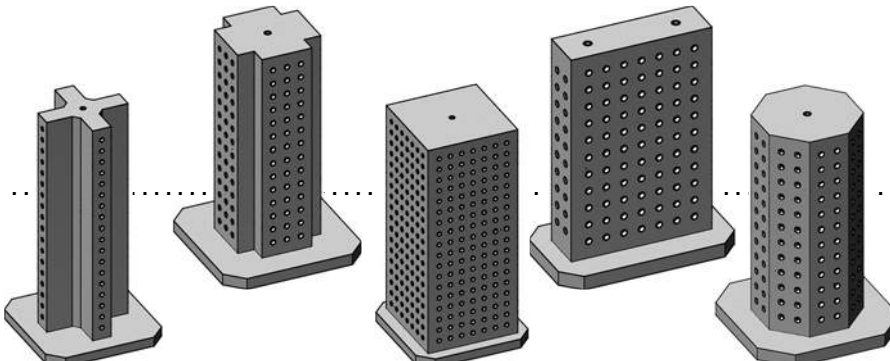

**Mineralgusserhöhung für 5-Achsenmaschinen
 Epoxy casting raises blocks for 5-axis machines** 271

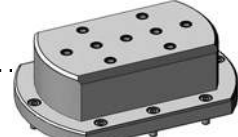

Stahl Mineralguss | Steel epoxy mineral tombstones 272 - 273



Zubehör | Accessories 274 - 275

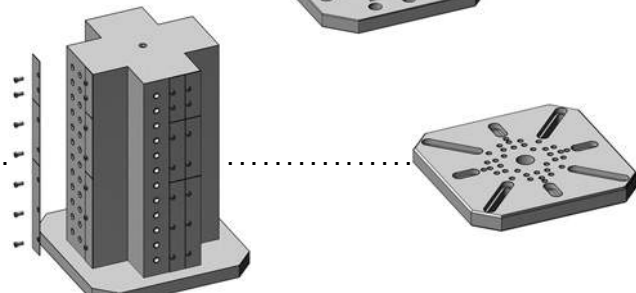

**Stahl Mineralgusserhöhungen mit integriertem Vakuum Anschluss / Steel-epoxy raises block with integrated vacuum
 Balken und Würfel aus Stahl-Mineralguss
 Trunion and cubes made from steel epoxy** 277

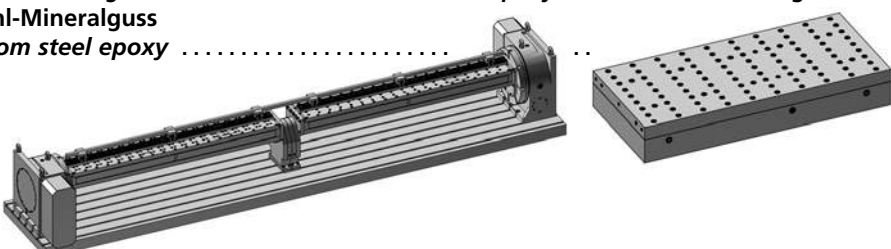

Es ist ein versprechen!
Unsere Mineralgusstürme stehen gerade!

*It's a promise!
Our epoxy tomb stones stand upright!*



Maschinenschonend und leicht, in fast allen Formen herstellbar

Bei den immer schneller werdenden Horizontalbearbeitungszentren ist Gewichtsreduktion der Zuladung ein wichtiger Faktor. Unsere Spanntürme aus Mineralguss haben ein kleineres spezifisches Gewicht als Alu.

Zudem werden Vibrationen derart reduziert, dass auch bei einer Bearbeitung im oberen Turmbereich präzise bearbeitet werden kann. In gewissen Fällen, z.B. bei Werkstückspannungen (ohne Basisschienen) direkt auf den Turm, kann auch ein stahlummantelter Mineralgussturm eine Ergänzung sein.

Reduces machine wear due to low specific weight - can be produced in all sorts of shapes

As the rapid traverse on modern horizontal machining centres is constantly increasing, the weight of the payload becomes obviously an important point. Our tombstones made of epoxy mineral casting are lighter in their specific weight than aluminium.

In addition, vibrations are greatly reduced in a way that even in the upper end of the tombstone high accuracy is guaranteed. In certain cases, as for instance when the fixture is designed without the base rail, that means directly mounted on the cube, the tombstone can be improved by a steel jacket.

- Leicht und stabil
- Vibrationsdämpfung 10 x besser als Grauguss und 100 x besser als Alu!
- Spezifisches Gewicht leichter als Aluminium
- Seitenflächen geschliffen mit Bohrungen (M12 / 12F7)
- Grundplatten nach Maschinenspezifikation
- Andere Formen auf Anfrage

- *Lightweight and rigid*
- *Damping effect 10 x better than cast iron 100 x better than alu!*
- *Specific weight lighter than aluminum*
- *Faces ground, hardened bushings (M12/12F7)*
- *Base plate made to machine specifications*
- *Other dimensions on request*

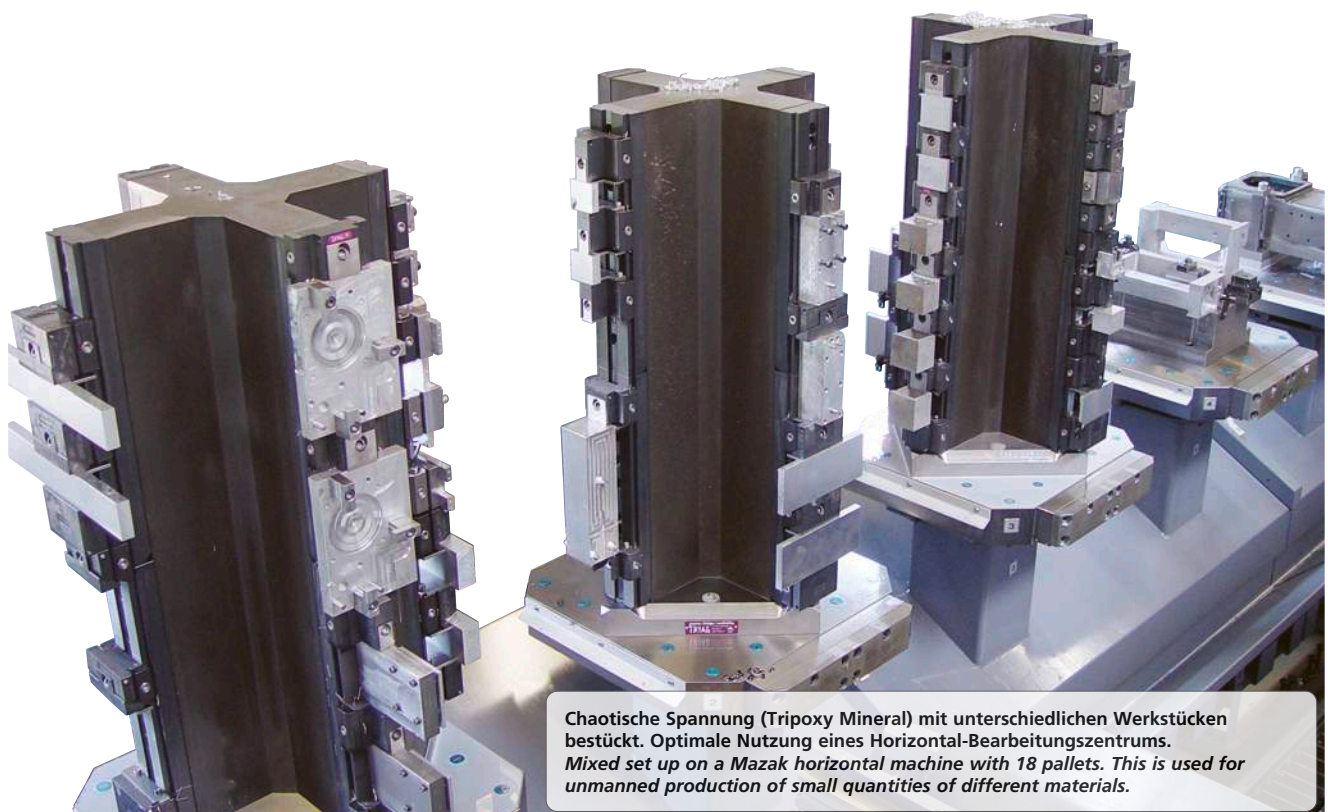

Chaotische Spannung (Tripoxy Mineral) mit unterschiedlichen Werkstücken bestückt. Optimale Nutzung eines Horizontal-Bearbeitungszentrums. Mixed set up on a Mazak horizontal machine with 18 pallets. This is used for unmanned production of small quantities of different materials.

Mineralguss (auch Polymerbeton genannt) ist ein Kunststein, bestehend aus Quarzkies, Quarzsand und Gesteinsmehl. Als Binder dient ein hochwertiger Epoxidharz. Das gemischte Material wird in Giessformen gefüllt.

Während dem Giessprozess wird die Form, mittels Vibrations-tisch ständig vibriert, was zur Verdichtung und Entlüftung der Giessmasse führt. Das spezifische Gewicht ist mit 2,4 kg / dm³ geringer als das von Aluminium und die Vibrationsdämpfung ist 10 mal besser als bei Grauguss, 100 mal besser als Aluminium. Neben den guten Dämpfungseigenschaften ist auch die Temperaturstabilität (geringe Wärmeleitfähigkeit und hohe Wärmekapazität) zu erwähnen.

Das Material ist ausserdem chemisch beständig gegen Öle, Laugen, Säuren und die üblichen Kühlschmierstoffe. Im ausgegossenen Zustand sind die Türme «Umweltneutral».

Mineral casting (also called polymer concrete) is a stone composed of quartz gravel, silica sand and crushed rock. The binder is a high quality epoxy resin. The mixed material is filled into molds.

During the casting process, the form, constantly vibrating. Is resulting in the compaction and extraction of the casting mass. The specific weight is 2,4 kg / dm³ is lower than that of aluminum, and the vibration attenuation is 10 times better than that of cast iron 100 times better than alu. Besides the good damping properties, the temperature stability is to be mentioned (low thermal conductivity and high heat capacity).

The material is also chemically resistant to oils, alkalis, acids and the usual cooling lubricants.

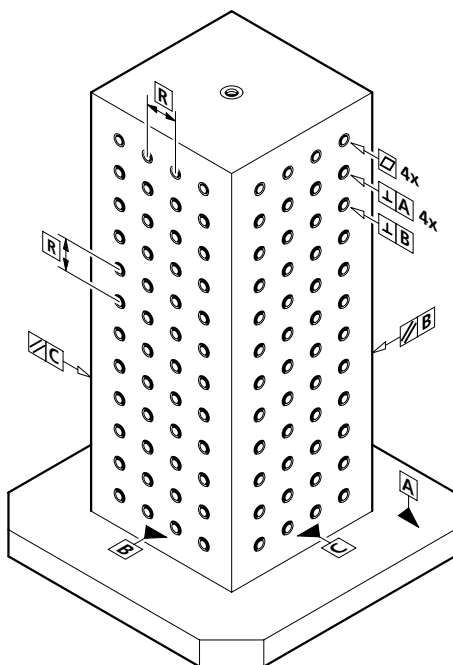

| Eigenschaften Caractéristiques | Mineralguss Epoxy mineral | GG20 | hochfestes Alu high density Alu |
|--|---------------------------------|-------------------------|---------------------------------------|
| Dichte / Density [kg/dm ³] | ca. 2,4 | ca. 7,1-7,3 | ca. 2,76 |
| Logarithmisches Dekrement grösser als (Vibrationsdämpfung) Logarithmic Decrement (damping) | 0,035 | 0,004 | 0,0004 |
| Längenausdehnungs-koeffizient Coefficient of linear expansion [1/K] | ca. 12x10 ⁻⁶ | ca. 10x10 ⁻⁶ | ca. 23x10 ⁻⁶ |
| Zugfestigkeit / Tensile strength [N/mm ²] | 15 - 20 | 200 - 400 | 470 - 520 |
| Wärmeleitfähigkeit Thermal conductivity [W/mK] | ca. 2 | ca. 50 | ca. 140 |

| | | |
|--|----------|---|
| Lagetoleranz der Rasterbohrungen Positioning tolerance of the holes | R | 0 - 500 mm ± 0,01 501 - 1000 mm ± 0,02 |
| Ebenheit Flatness | | 0,01 mm / 300 mm |
| Parallelität Parallelism | | 0,01 mm / 300 mm |
| Winkligkeit Deviation of angle | | 0,01 mm / 200 mm |

Mineralguss wird unter anderem für folgende Anwendungen eingesetzt: Cast mineral is among other things the following Applications used:

- ➔ Maschinenbetten
Machine beds
- ➔ Maschinenständer und -portale
Machine column and portals
- ➔ Als Alternative zu Grauguss (Kosten, Umweltfreundlichkeit)
As an alternative to cast iron (cost, environmental friendliness)
- ➔ Als Alternative zu Schweisskonstruktionen
As an alternative to welded constructions
- ➔ Als Alternative zu Natursteinanwendungen (z.B. Messtische, Reinraumtechnologie)
As an alternative to natural stone applications (eg, measuring tables, clean room technology)
- ➔ Generell steifigkeits- und festigkeitsdimensionierte Strukturbauteile
General stiffness and strength-scale structural components
- ➔ Integrierte Funktionalität möglich (Schläuche, Ventile, Elektrik, Lastanker etc.), auch nachträgliches Eingiessen möglich
Integrated functionality possible (hoses, valves, electrical, anchor load, etc.), and subsequent pouring possible
- ➔ Füllung von Mineralguss in Blechmantelkonstruktionen (z.B. unsere Stahl-Mineralguss-Basissschienen)
Filling of mineral cast in metal shell constructions (eg, our steel rails with epoxy mineral cast base)

tripoxyMINERAL

Die Gewichtsreduktion der Zuladung ist bei den immer schneller werdenden Horizontalbearbeitungszentren ein wichtiger Faktor. Die Spanntürme aus Mineralguss haben ein kleineres spezifisches Gewicht als Aluminium. Diese verfügen über eine so hohe Vibrationsdämpfung, dass dadurch im oberen Bereich der Türme sehr präzise gearbeitet werden kann und dabei exzellente Oberflächengüten erreicht werden.

Seit Jahren bietet die Triag International AG aus eigener Produktion mit den Tripoxy Mineral-Spanntürmen eine sehr gute Alternative zu Spanntürmen aus anderen Materialien (z.B. Grauguss- oder Aluminium) an.

The weight reduction of the load is an important factor in the increasingly rapid horizontal machining centers. The tombstones of mineral casting have a lower specific weight than aluminum. Another big advantage is the vibration clamping which helps to achieve excellent surfaces on your workpieces, even on top of your tombstone. Beside that there are another two good reasons for epoxy mineral tombstones. One is the materials is not getting rusty and the slow thermal expansion.

For years, the Triag International AG offers its own production with the Tripoxy mineral tombstones, a very good alternative to tombstones made of other materials (such as cast iron or aluminum) to.

**Mineralgusstürme samt
 Spansystem aus einer Hand!**

**Epoxy mineral tombstones including
 clamping system from one source!**



Mineralgussturm kombiniert bestückt mit Power Clamp und Magneten.
 Epoxy cube equipped with magnet and Power Clamp



Grosse Platte auf einem rechteckigen Mineralgussturm.
 Large plates on epoxy tombstone.



Chaotische Fertigung auf einem Mineralgussturm in Kreuzform.
 Mixed set up on cross epoxy tombstone.

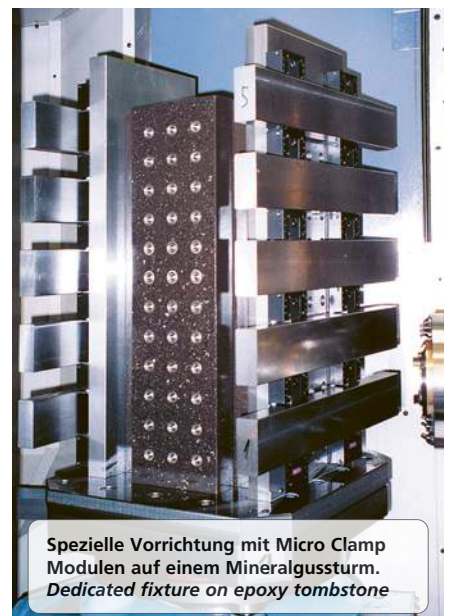

Spezielle Vorrichtung mit Micro Clamp Modulen auf einem Mineralgussturm.
 Dedicated fixture on epoxy tombstone

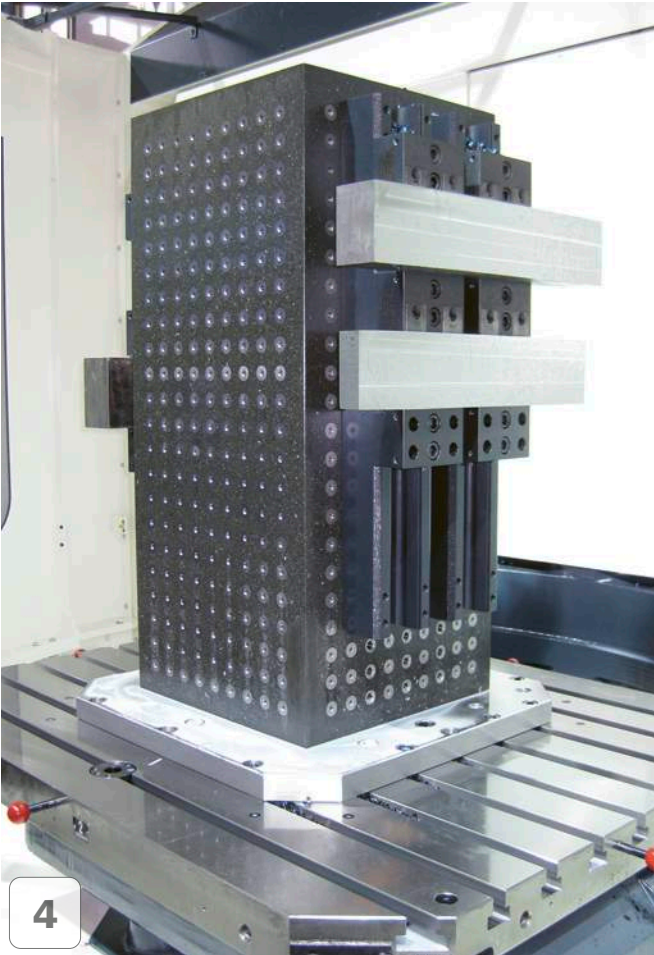
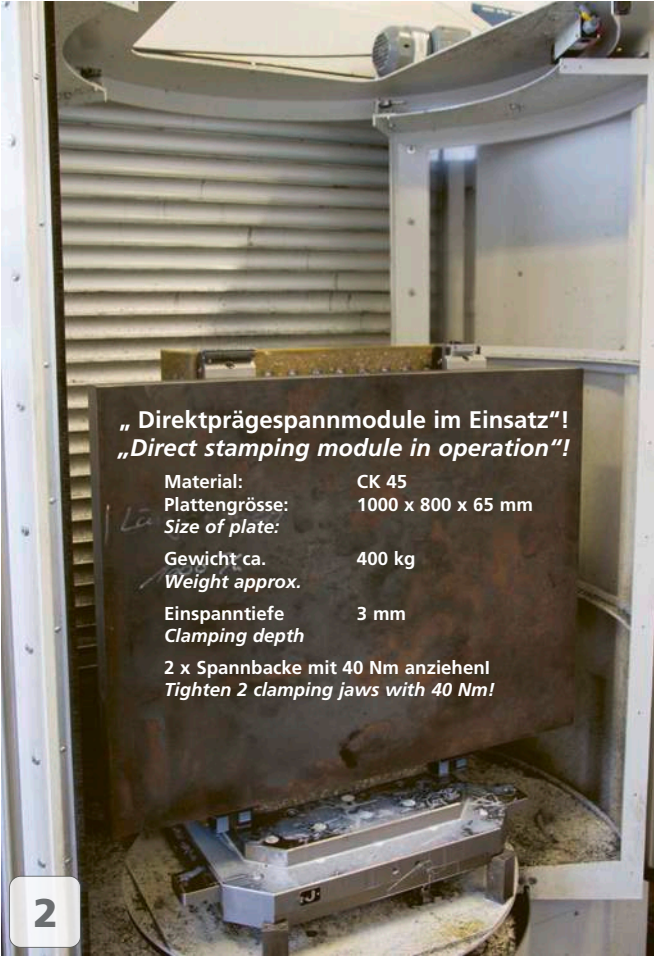

Stahl-Mineralguss

Steel-epoxy mineral tombstones

tripoxyMINERAL

Stahl-Mineralguss seit 2004 - das ideale Material für Spanntürme

Die Firma Triag International AG hat seit 2004 diese stahlummantelten Türme mit sehr guten Ergebnissen bei Kunden im Einsatz. In den meisten Fällen können optimale Lösungen durch Standardangebote kostengünstig und modular eingerichtet werden.

Steel-epoxy combinations since 2004 - the ideal material for tombstones and ricer cubes

Triag International AG customers are employing successfully tombstones with steel jackets since 2004. In most cases optimal solutions can be found with standard Triag clamping devices.

Stahl-Mineralguss für die perfekte Vibrationsdämpfung
Steel epoxy tombstone for perfect vibration dampening

Max. Palettenzuladung auf Mazak H BZ
Max pallet load on this Mazak application = 600kg H = 800

Komplettes Gewicht 600 kg inkl. Werkstücke WS = 8 x 38 kg
Complete load weighs 600 kg incl-parts

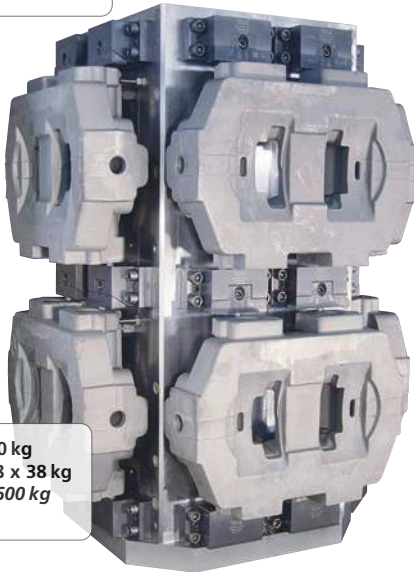

200 x 400 x 1330

Flügelteil für Airbus A320
Tail wing part for Airbus A320

Stahlmineralguss-Säulen mit Power Clamp für die Fertigung von Flügelteilen.
Steel epoxy frames machining wing parts on a Makino machine

Stahl-Mineralguss Dreieck-Turm
Steel epoxy triangle cube



Stahl-Mineralguss Pyramide
Steel epoxy pyramid stomp

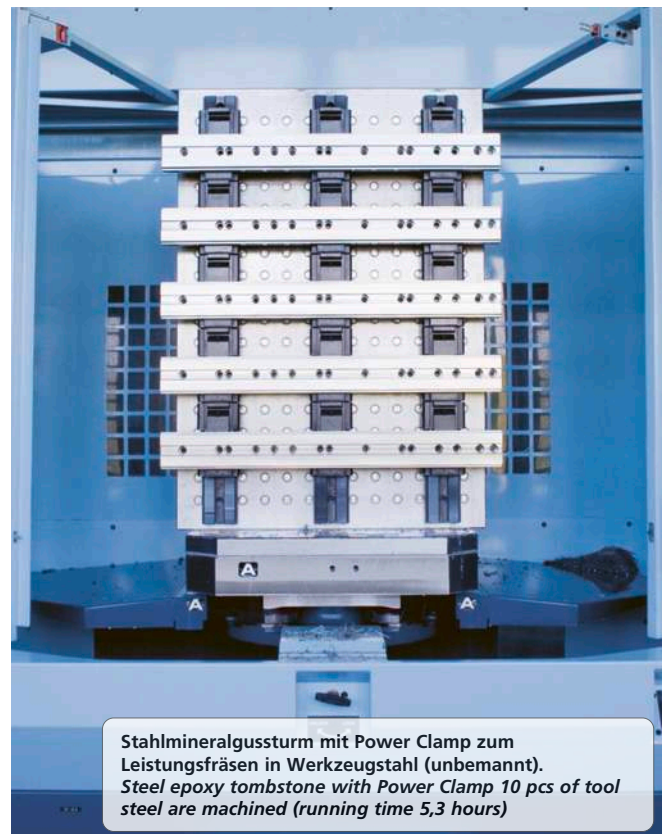
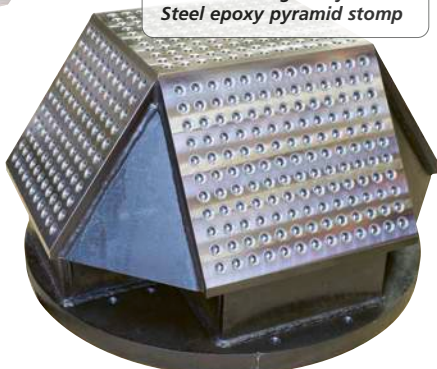

Stahlmineralgussturm mit Power Clamp zum Leistungsfräsen in Werkzeugstahl (unbemannt).
Steel epoxy tombstone with Power Clamp 10 pcs of tool steel are machined (running time 5,3 hours)

Es gibt eine Vielzahl von Standardformen

There are a variety of standard forms

tripoxyMINERAL

Die Mineralgusstürme können in fast allen

*The epoxy mineral tombstones can be manu-
factured in almost any shape.*

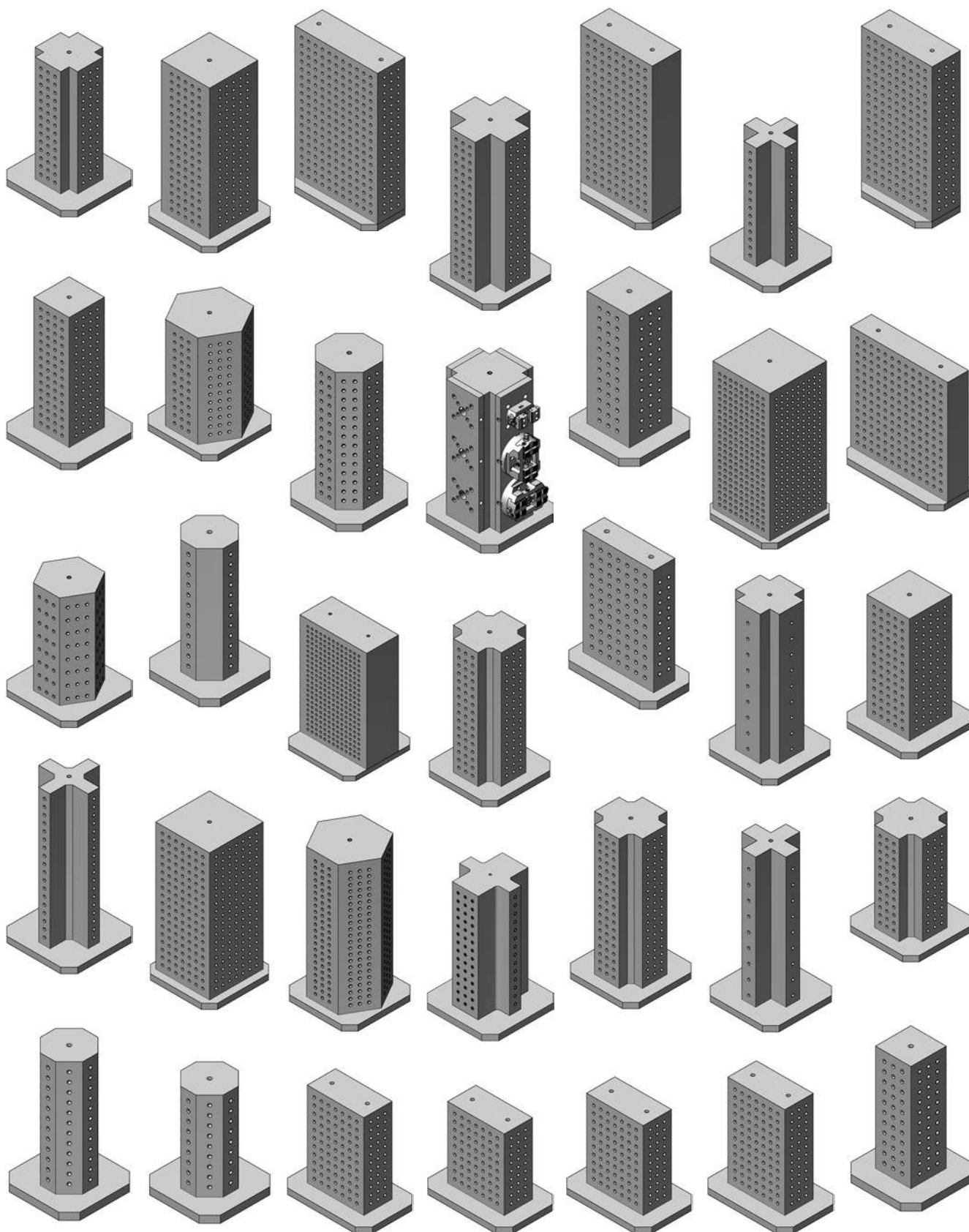

Andere Grössen, Formen und Raster, welche nicht im Katalog sind, können nach Kundenwunsch produziert werden.
Other sizes, forms and grid which are not in the catalogue can be produced on customer's request.

ACHTUNG / CAUTION

Bevor Mineralgusstürme eingesetzt werden, beachten Sie bitte die folgenden Punkte! *Prior to inserting the tombstones please note the following points!*

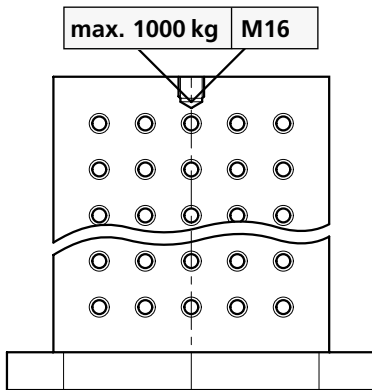

| Höchstlast des angehängten Stücks / Maximum load of the affixed piece | | |
|---|--|--|
| Drahtseil Steel rope | Bei fest angezogener Schraube For tightened screw | Bei zwei Schrauben insgesamt For two tightened screws |
| | | |
| MRD 12 = 500 kg MRD 16 = 1000 kg | M12 = 340 kg M16 = 700 kg (DIN 580) | M12 = 240 kg M16 = 500 kg (DIN 580) |

Bitte beachten Sie, dass die meisten Ringschrauben eine maximale Last haben von: **M12: 340 kg / M16: 700 kg** auch muss die Ringschraube bis zum Anschlag eingedreht sein!

*Please note that most of the lifting screws have a maximum load of: **M12: 340 kg / M16: 700 kg** It is also important that the lifting screw is driven into the socket!*

Oberflächenabnutzung

Durch schnelle, auf die Turmoberfläche schlagende Späne, sowie durch Hochdruckkühlung, die direkt auf den Turm spritzt, kann die Oberfläche des Mineralgussturmes beschädigt werden!

Surface wear

The surface of the tombstone can be seriously damaged by chips hitting the tombstone quickly as well as by high pressure cooling water splashing directly onto the tombstone!

Massnahmen:

Dort wo lange Späne oder auch kurze abrasive Späne auf den Turm schlagen, Abdeckbleche benutzen! (Abdeckbleche siehe Seite 244)

Measure:

Use cover sheets wherever long or short abrasive chips hit the tombstone! (Cover sheets page 244)

Achtung Grenzfälle

Folgende Anwendungen können nur bedingt eingesetzt werden, da eine einzelne Schraube auf Zug ohne Gegenlast die eingegossene Buchse belastet!

Attention, limited application

The following applications only have limited use as a single screw without a counterweight puts tremendous tension on the integral socket!



Max. Anzugsmomente beachten.

Note max. starting torques.

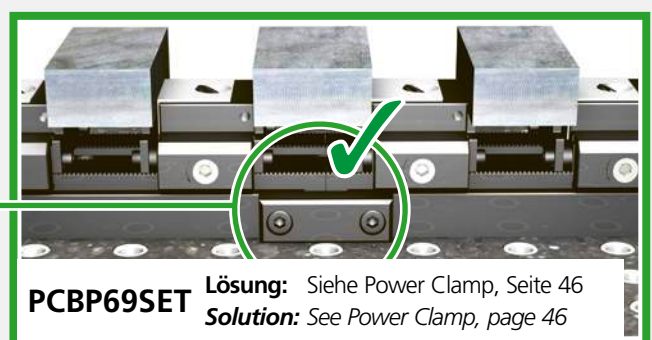
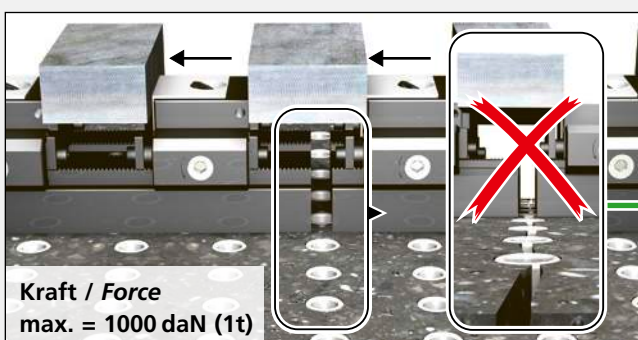
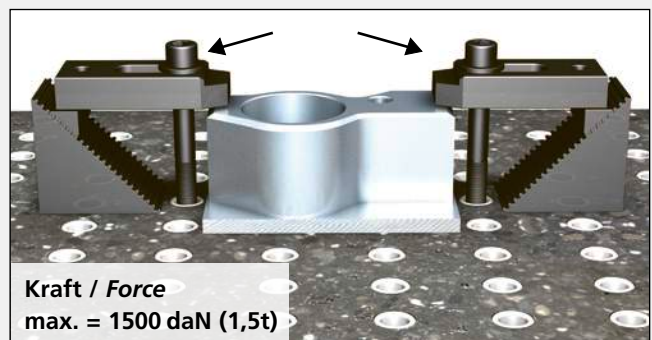
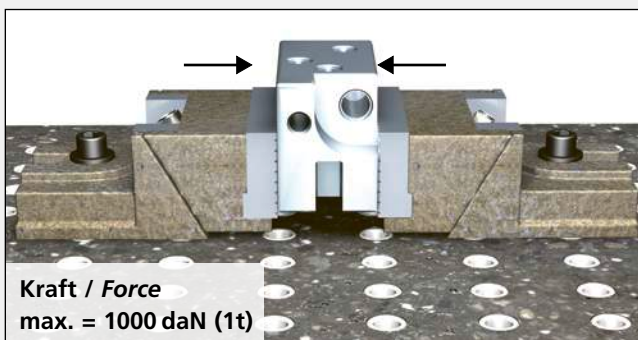

Bruchstelle

Bruchstelle des Mineralgussturmes mit Aceton reinigen, danach mit Metallplatte und Schraubzwinde einschalen. Bei grossen Reparaturen sollte die Platte zusätzlich mit Hartwachs (Bild 6) eingerieben, poliert und nachträglich mit Silikon abgedichtet werden. (Siehe Bilder 1-4)

Mineralgussreparaturset (Bild 5)

MREP-SET 0300 ~ 300 gr = ~ 2 dl

Das Reparaturset setzt sich aus dem Harz, Härter und Füller zusammen. Das Mischverhältnis ist: auf 27 gr Härter kommt 100 gr Harz und 150 gr Füller.

Das Verhältnis ist genau abgewogen. Wichtig ganze angelieferte Menge gebrauchen.

Harz und Härter zusammengiessen und intensiv 2 Min. rühren. Das Durchmischen der Masse ist entscheidend für das optimale Abbinden des Mineralgusses. **Danach Füller dazugeben und das gleiche nochmals 2 Min.** lang untereinander mischen bis eine gipsähnliche Masse entsteht.

Die flüssige Masse wird nun in die Bruchstelle eingegossen.

Das Aushärten der Reparaturmasse beträgt 24 Std. Die Unebenheit der frisch eingegossenen Fläche, wird mit einem Schleifstein plangeschliffen.

Point of rupture

Clean the section of fracture with Acetone, then press metal plates with screw clamps onto the point of damage. If the damage is a major one the metal plates must be waxed first (picture No. 6) and sealed with Silicon if necessary (pls. note pictures 1 to 4)

Repair kit for epoxy mineral castings (picture 5)

MREP-SET 0300 ~ 300 gr = ~ 2 dl

The repair kit consists of the resin, the hardener, and the filler. The mixture ratio is: 27 gr of hardener, 100 gr of resin and 150 gr of filler.

These components are exactly portioned in the kit and should be used up entirely.

The resin and the hardener should be poured together and mixed for 2 min. This mixing process is essential for a good bonding with the mineral casting. **Then the filler should be added while mixing the mass another 2 min.** It will reach a consistency like plaster.

This mortar must be poured into the point of rupture.

The hardening process takes 24 hours. Protruding material can be levelled with a grindstone.

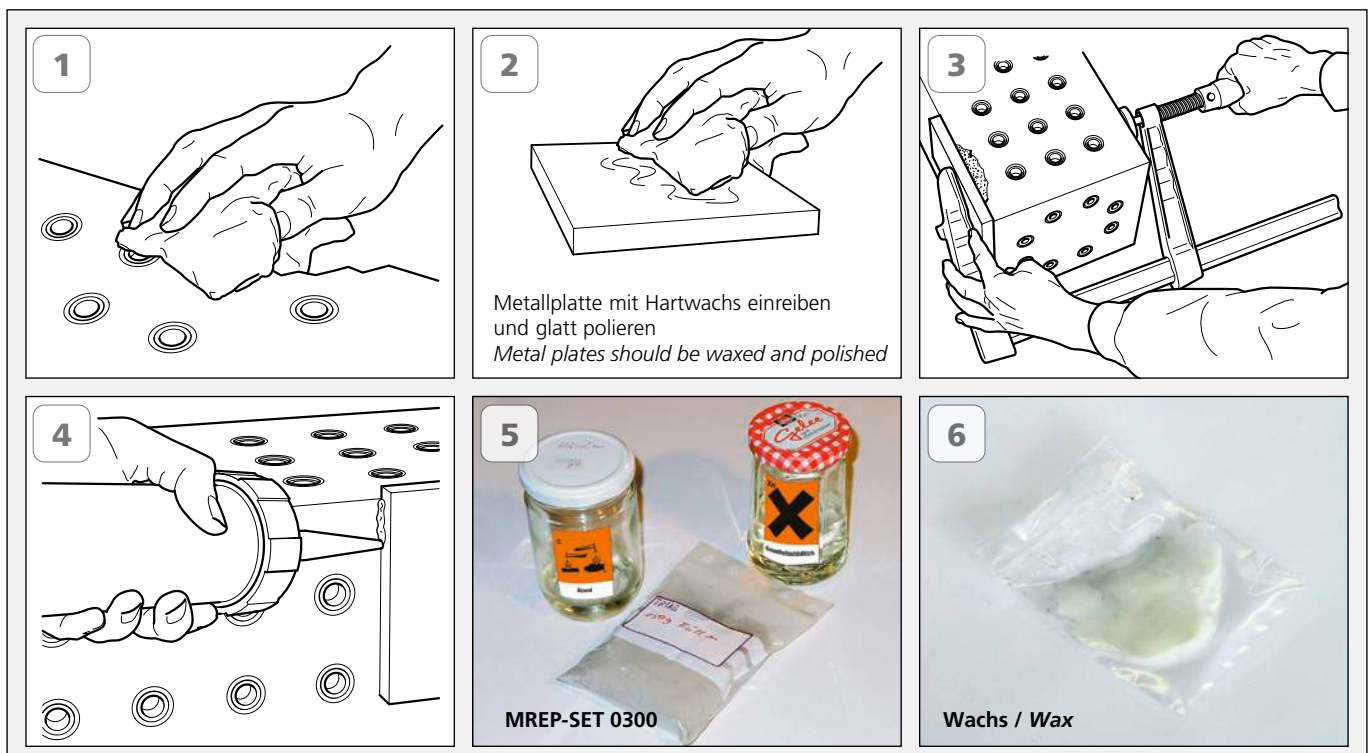

| | | | |
|------------------------------------|--|--|------------------------------|
| Kunde <i>Customer</i> | | | |
| Maschine <i>Machine</i> | | Werkstoff, Halbzeug, Rohteil-Nr., Modell- oder Gesenk-Nr. <i>Raw material, blank or casting-Nr.</i> | |
| X max. | X Achse Hub <i>X axis stroke</i> | | mm |
| Y min. | Kleinster Abstand von der Palettenoberseite zur Spindelachse <i>Smallest distance from pallet surface to spindle center</i> | | mm |
| Y max. | Grösster Abstand von der Palettenoberseite zur Spindelachse <i>Greatest distance from pallet surface to spindle center</i> | | mm |
| Z min. | Kleinster Abstand von der Palettenachse zur Spindelchse <i>Smallest distance from pallet center to spindle gauge line</i> | | mm |
| Z max. | Grösster Abstand von der Palettenachse zur Spindelchse <i>Greatest distance from pallet center to spindle gauge line</i> | | mm |
| ∅ Spindel <i>Spindle</i> | Spindeldurchmesser <i>Spindle diameter</i> | | mm |
| kg max. | Maximale Tischbelastung <i>Maximum loading capacity</i> | | kg |
| ∅D max. | Maximaler Störkreis des Werkstücks <i>Maximum workpiece diameter</i> | | mm |
| H max. | Maximale Beladehöhe des Werkstücks <i>Maximum workpiece height</i> | | mm |
| A x B | Palettenabmessung <i>Size of pallet</i> | | mm |
| | Anzahl Werkstücke pro Los <i>Number of workpieces per lot</i> | | Stück <i>Piece</i> |

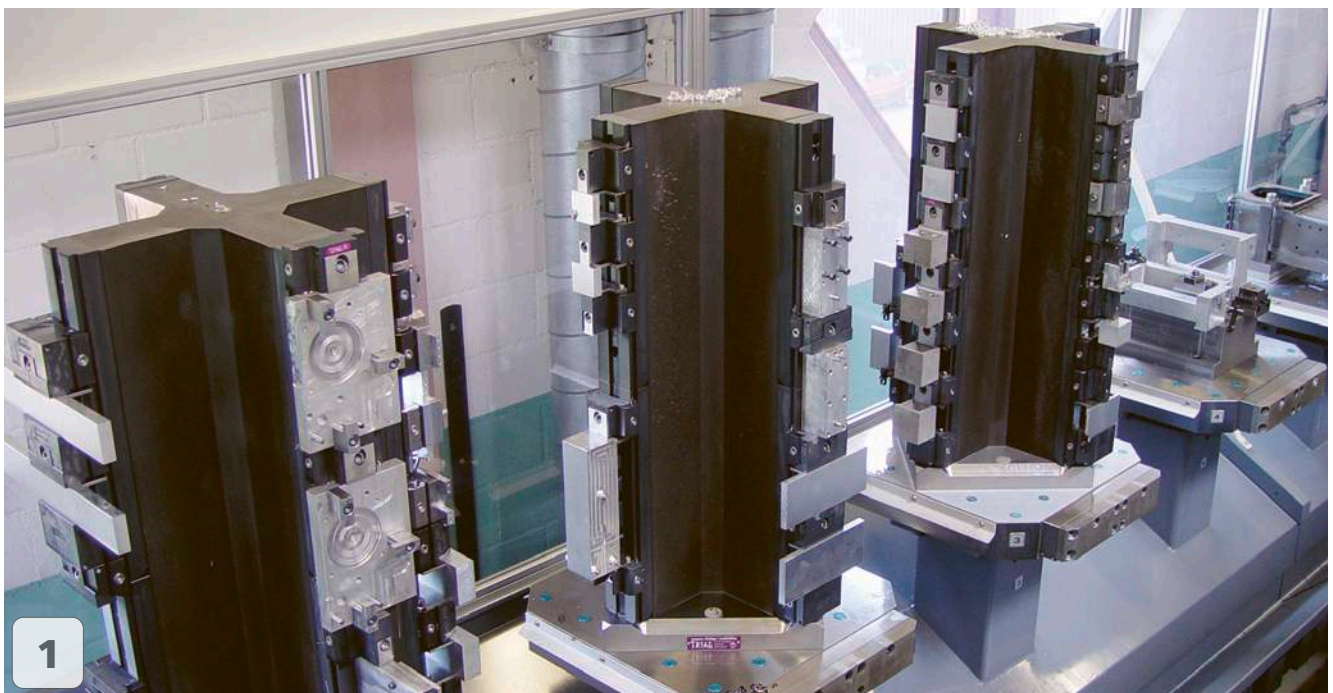
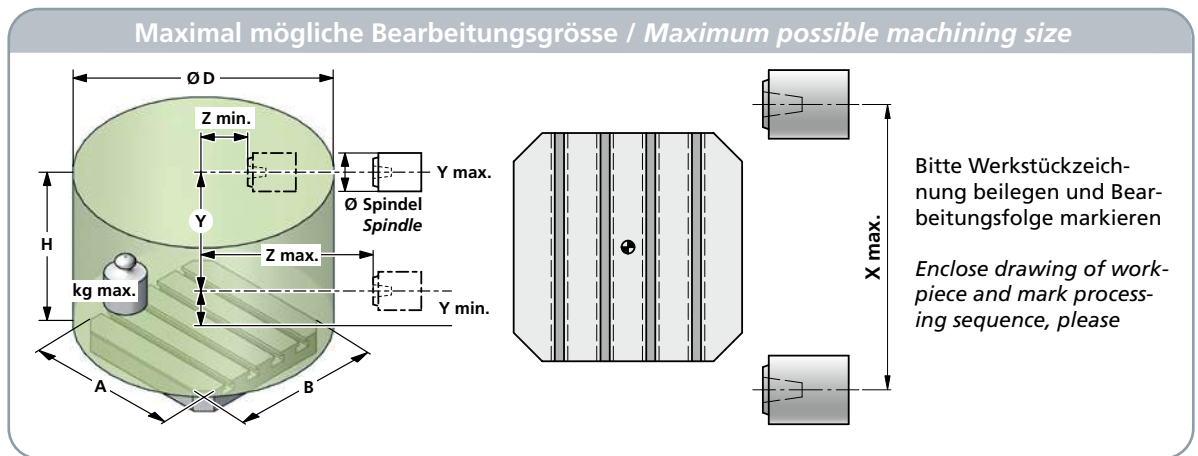

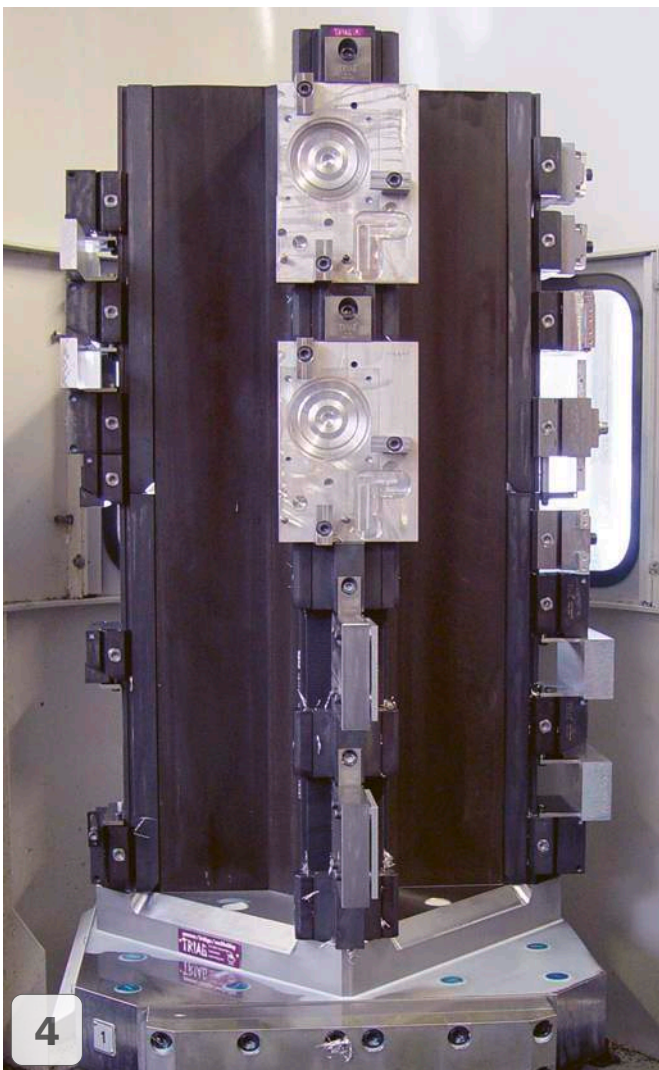
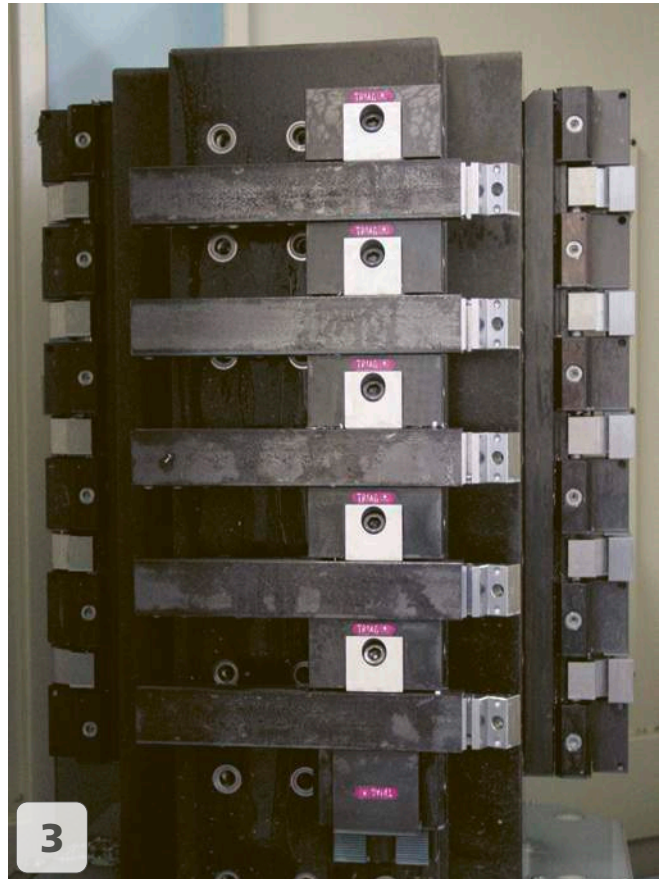
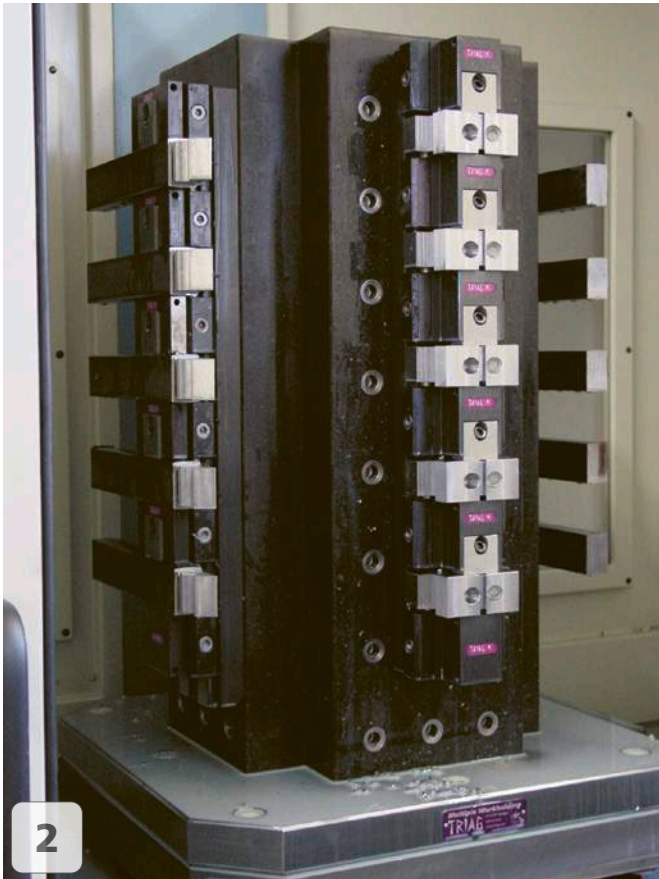

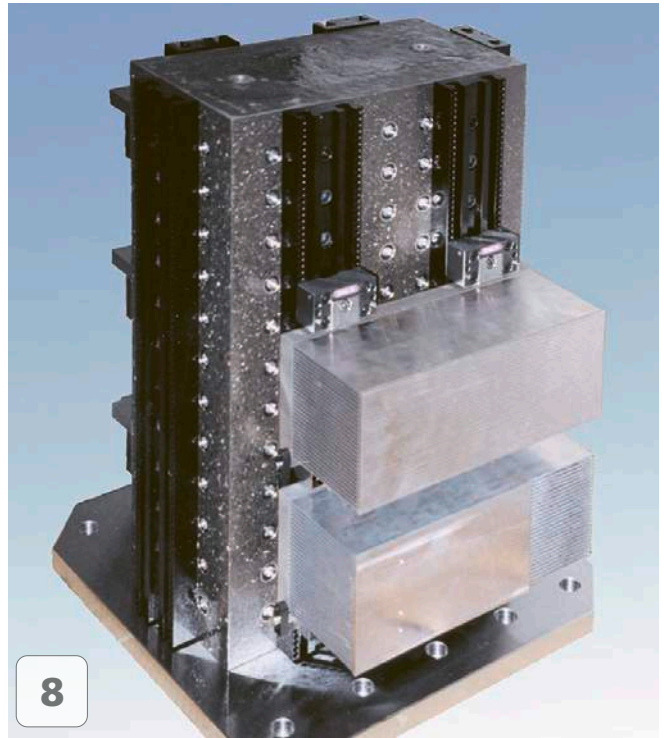

Stahl-Mineralguss Lösungen / Steel epoxy mineral tombstones solutions

SMK24-24-42 OPP200 ~ **120kg**

Pyramidenstumpf
Truncated pyramid ~ **474kg**

SMK30-17-42 OPP200 ~ **142kg**

| Turm-Material <i>Tombstone material</i> | |
|--|--|
| M | Mineralguss mit Stahldübel <i>Epoxy mineral with steel anchor</i> |
| SM | Stahl Mineralguss <i>Steel epoxy mineral tombstones</i> |
| G | Grauguss <i>Cast iron</i> |

| Grösste Schlüsselweite <i>Major width</i> | |
|--|--------|
| 12 | 120 mm |
| 20 | 200 mm |
| 24 | 240 mm |
| 25 | 250 mm |
| 30 | 300 mm |
| 32 | 320 mm |
| 35 | 350 mm |
| 40 | 400 mm |
| 42 | 420 mm |
| 50 | 500 mm |
| 60 | 600 mm |
| 63 | 630 mm |
| 70 | 700 mm |

| Höhe <i>Height</i> | |
|-----------------------|--------|
| 50 | 500 mm |
| 55 | 550 mm |
| 56 | 567 mm |
| 60 | 600 mm |
| 62 | 620 mm |
| 65 | 650 mm |
| 66 | 660 mm |
| 70 | 700 mm |
| 75 | 750 mm |
| 80 | 800 mm |
| 85 | 850 mm |
| 90 | 900 mm |
| 95 | 950 mm |

M

K

35

18

95

R50

| Modultyp <i>Type of module</i> | |
|-----------------------------------|-------------------------------------|
| K | Kreuz <i>Cross</i> |
| Q | Quadrat <i>Square</i> |
| R | Rechteck <i>Rectangular</i> |
| S | Sechseck <i>Hexagonal</i> |
| A | Achteck <i>Octagonal</i> |
| X | Spezialform <i>Special shape</i> |

| Aufspannbreite <i>Usable width</i> | |
|---------------------------------------|-------------|
| 08 | 80 mm |
| 09 | 90 mm |
| 86 | 86 mm |
| 10 | 100 mm |
| 12 | 120 mm |
| 15 | 150 mm |
| 16 | 160 mm |
| 18 | 180 mm |
| 1808 | 180 / 80 mm |
| 19 | 184 mm |
| 20 | 200 mm |
| 23 | 231 mm |
| 24 | 240 mm |
| 25 | 250 mm |
| 30 | 300 mm |
| 35 | 350 mm |
| 40 | 400 mm |
| 42 | 420 mm |

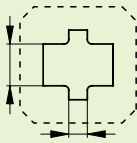

| Raster <i>Grid</i> | |
|-----------------------|--------|
| R40 | 40 mm |
| R50 | 50 mm |
| R80 | 80 mm |
| R100 | 100 mm |
| OPP | 200 mm |

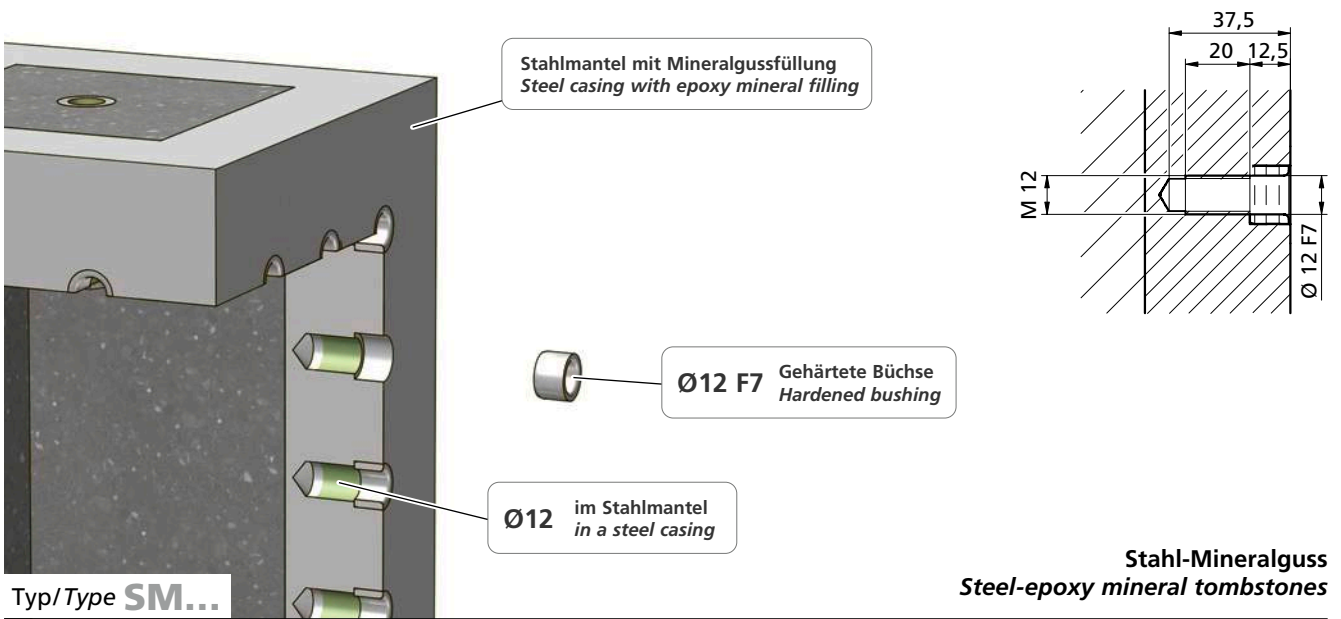
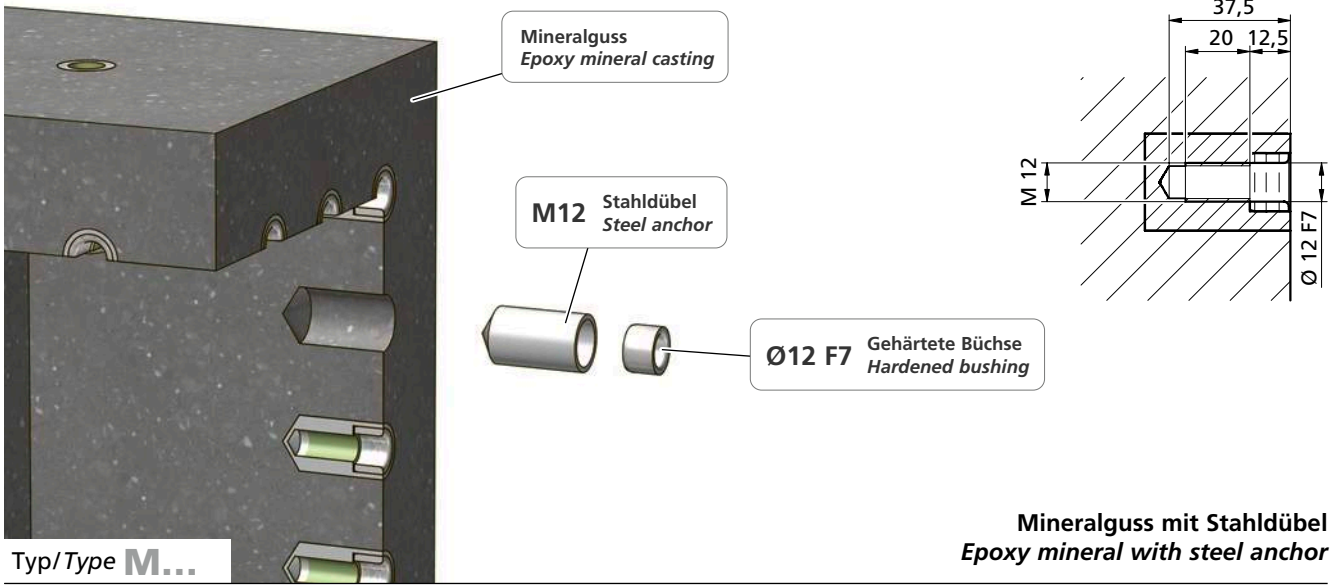

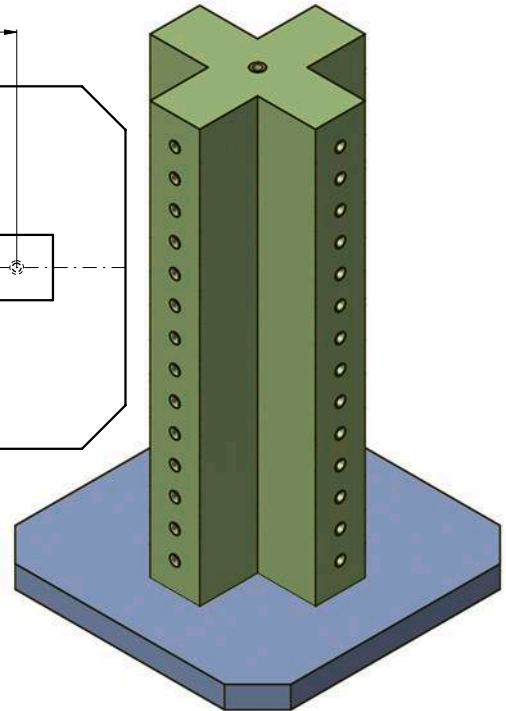
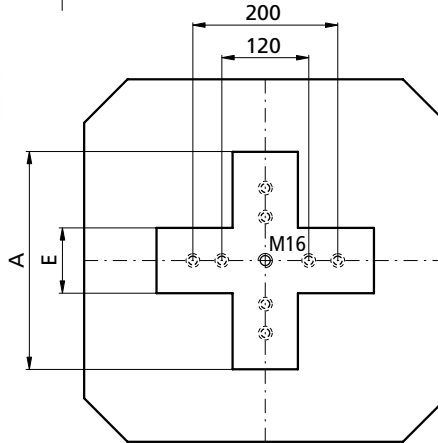
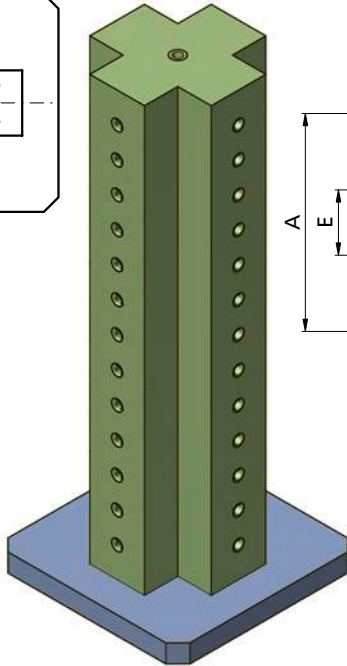
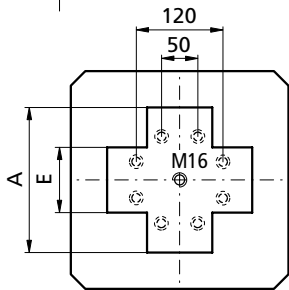
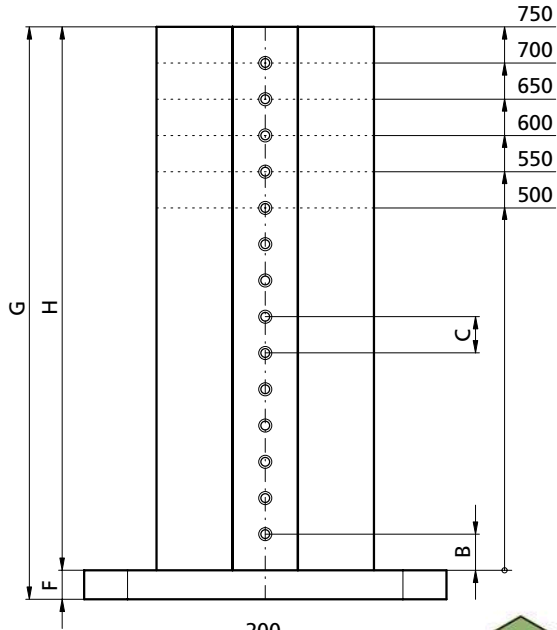
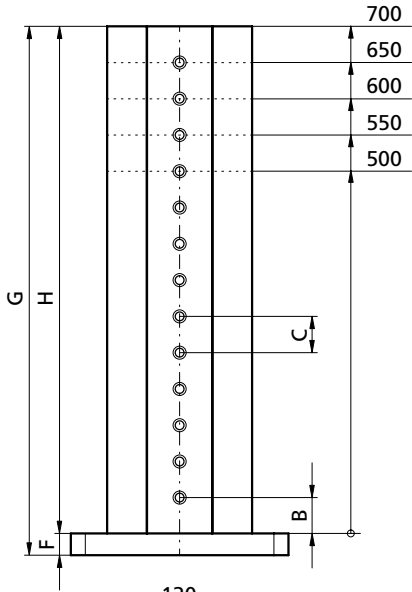

Grundplatte wird passend zu Ihrer Maschinenpalette hergestellt und muss separat bestellt werden!
Base plate according to your machine configuration please order extra!

Mineralgussturm mit Stahldübel
Epoxy Mineral with Steel Anchor

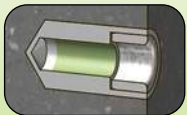

Seite / Page 250

Bestellbeispiel

Ordering example: MK200965R50 &

p. 274

| | kg* | A | B | C | E | F | G | H | Raster / Grid |
|-------------|-----|-----|----|----|----|------|-------|-----|---------------|
| MK200950R50 | ~38 | 200 | 50 | 50 | 90 | (30) | (530) | 500 | 36 x M12/12F7 |
| MK200955R50 | ~42 | 200 | 50 | 50 | 90 | (30) | (580) | 550 | 40 x M12/12F7 |
| MK200960R50 | ~45 | 200 | 50 | 50 | 90 | (30) | (630) | 600 | 44 x M12/12F7 |
| MK200965R50 | ~49 | 200 | 50 | 50 | 90 | (30) | (680) | 650 | 48 x M12/12F7 |
| MK200970R50 | ~53 | 200 | 50 | 50 | 90 | (30) | (680) | 700 | 48 x M12/12F7 |
| MK300950R50 | ~60 | 300 | 50 | 50 | 90 | (40) | (540) | 500 | 36 x M12/12F7 |
| MK300955R50 | ~66 | 300 | 50 | 50 | 90 | (40) | (590) | 550 | 40 x M12/12F7 |
| MK300960R50 | ~72 | 300 | 50 | 50 | 90 | (40) | (640) | 600 | 44 x M12/12F7 |
| MK300965R50 | ~78 | 300 | 50 | 50 | 90 | (40) | (690) | 650 | 48 x M12/12F7 |
| MK300970R50 | ~84 | 300 | 50 | 50 | 90 | (40) | (740) | 700 | 52 x M12/12F7 |
| MK300975R50 | ~90 | 300 | 50 | 50 | 90 | (40) | (790) | 750 | 56 x M12/12F7 |

* Gewicht ohne Grundplatte! / Weight without baseplate!

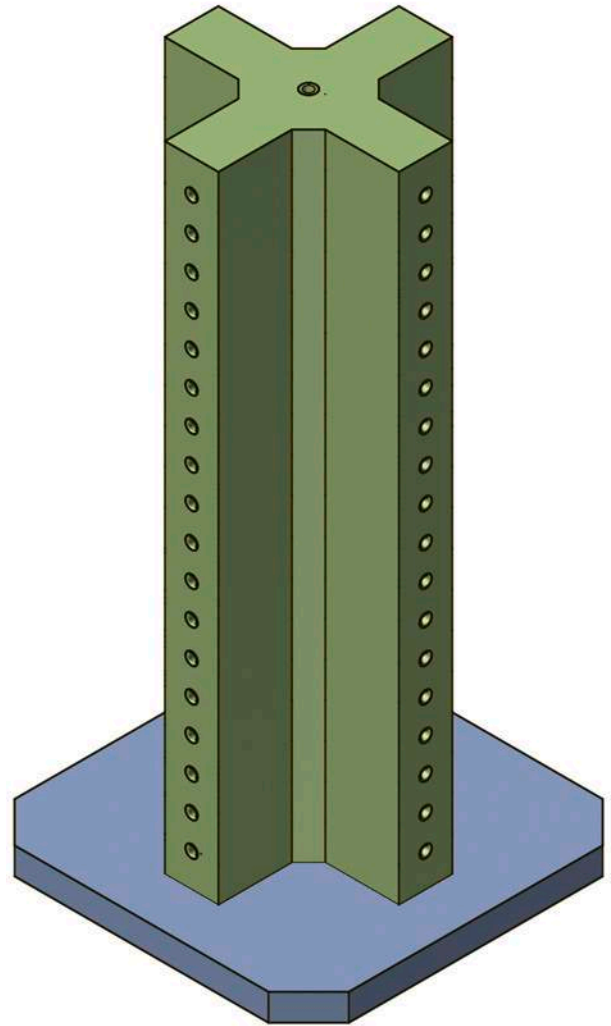
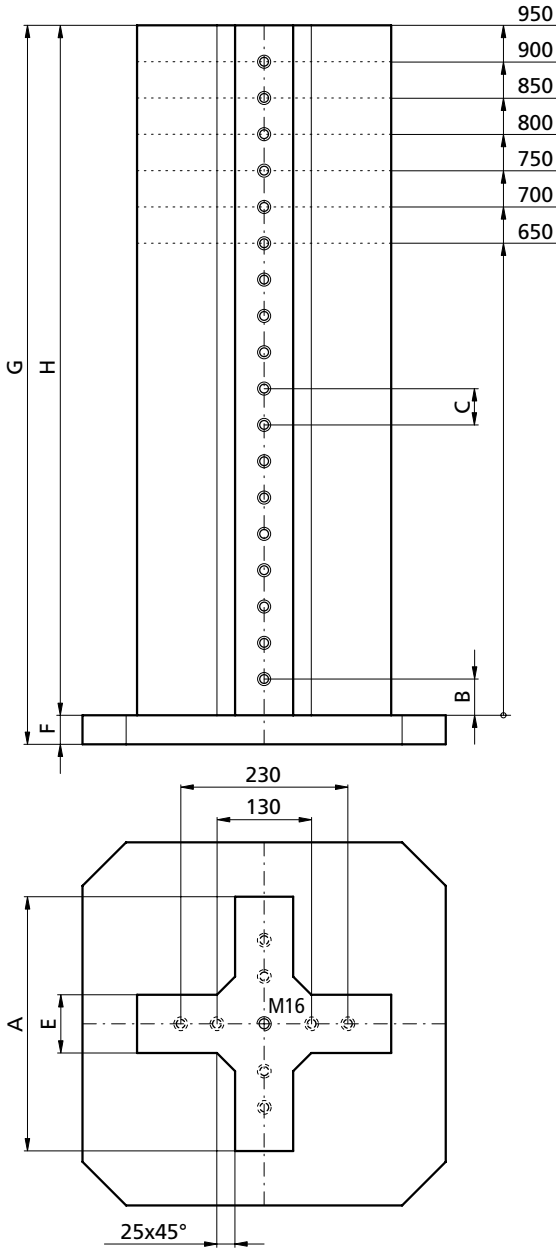

Grundplatte wird passend zu Ihrer Maschinenpalette hergestellt und muss separat bestellt werden!
Base plate according to your machine configuration please order extra!

Mineralgussturm mit Stahldübel
Epoxy Mineral with Steel Anchor

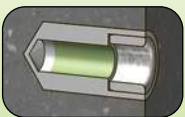

Seite / Page 250

Bestellbeispiel

Ordering example: **MK350865R50** & _____ p. 274

| | kg* | A | B | C | E | F | G | H | Raster / Grid |
|-------------|------|-----|----|----|----|------|-------|------------|---------------|
| MK350865R50 | ~85 | 350 | 50 | 50 | 80 | (40) | (690) | 650 | 48 x M12/12F7 |
| MK350870R50 | ~92 | 350 | 50 | 50 | 80 | (40) | (740) | 700 | 52 x M12/12F7 |
| MK350875R50 | ~99 | 350 | 50 | 50 | 80 | (40) | (790) | 750 | 56 x M12/12F7 |
| MK350880R50 | ~105 | 350 | 50 | 50 | 80 | (40) | (840) | 800 | 60 x M12/12F7 |
| MK350885R50 | ~112 | 350 | 50 | 50 | 80 | (40) | (890) | 850 | 64 x M12/12F7 |
| MK350890R50 | ~118 | 350 | 50 | 50 | 80 | (40) | (940) | 900 | 68 x M12/12F7 |
| MK350895R50 | ~125 | 350 | 50 | 50 | 80 | (40) | (990) | 950 | 72 x M12/12F7 |

* Gewicht ohne Grundplatte! / Weight without baseplate!

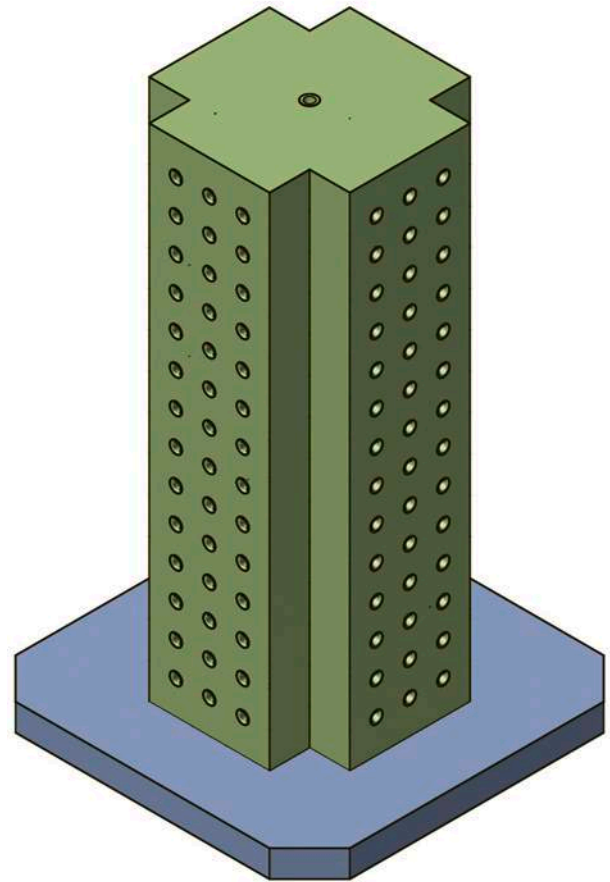
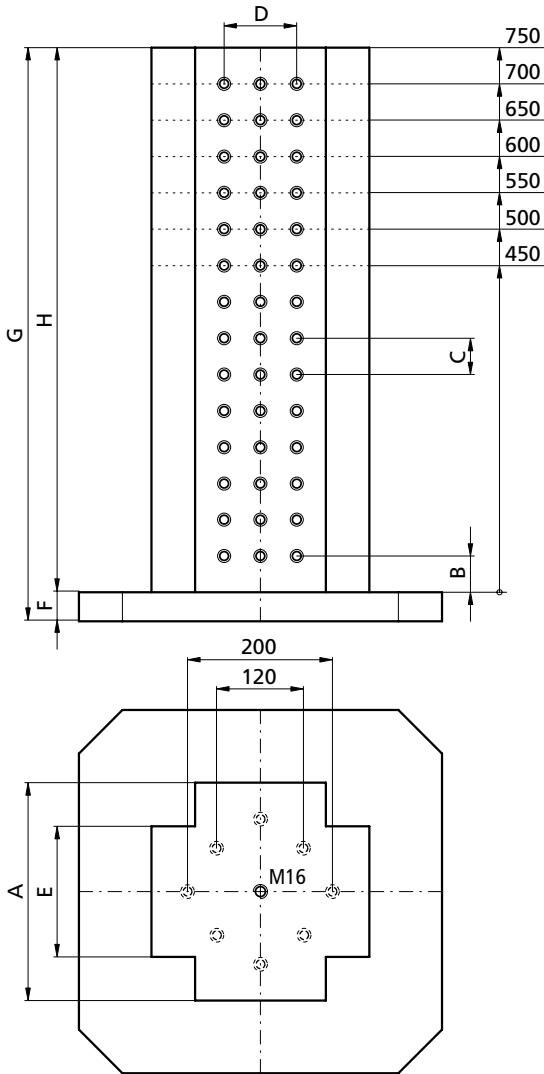

Grundplatte wird passend zu Ihrer Maschinenpalette hergestellt und muss separat bestellt werden!

Base plate according to your machine configuration please order extra!

p. 274

Mineralgussturm mit
Stahldübel
Epoxy Mineral with
Steel Anchor

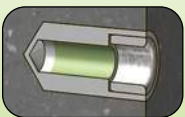

kg*

Stahl-Mineralguss
Steel-epoxy mineral
tombstones

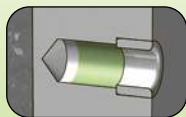

kg*

Seite / Page 250

Bestellbeispiel
Ordering example: **MK301850R50** &

| | | | | A | B | C | D | E | F | G | H | Raster / Grid |
|-------------|------|--------------|------|-----|----|----|-----|-----|------|-------|------------|---------------|
| MK301845R50 | ~77 | SMK301845R50 | ~100 | 300 | 50 | 50 | 100 | 180 | (40) | (440) | 450 | 96xM12/12F7 |
| MK301850R50 | ~86 | SMK301850R50 | ~110 | 300 | 50 | 50 | 100 | 180 | (40) | (540) | 500 | 108xM12/12F7 |
| MK301855R50 | ~94 | SMK301855R50 | ~120 | 300 | 50 | 50 | 100 | 180 | (40) | (590) | 550 | 120xM12/12F7 |
| MK301860R50 | ~102 | SMK301860R50 | ~132 | 300 | 50 | 50 | 100 | 180 | (40) | (640) | 600 | 132xM12/12F7 |
| MK301865R50 | ~110 | SMK301865R50 | ~141 | 300 | 50 | 50 | 100 | 180 | (40) | (690) | 650 | 144xM12/12F7 |
| MK301870R50 | ~117 | SMK301870R50 | ~152 | 300 | 50 | 50 | 100 | 180 | (40) | (740) | 700 | 156xM12/12F7 |
| MK301875R50 | ~125 | SMK301875R50 | ~162 | 300 | 50 | 50 | 100 | 180 | (40) | (790) | 750 | 168xM12/12F7 |

* Gewicht ohne Grundplatte! / Weight without baseplate!

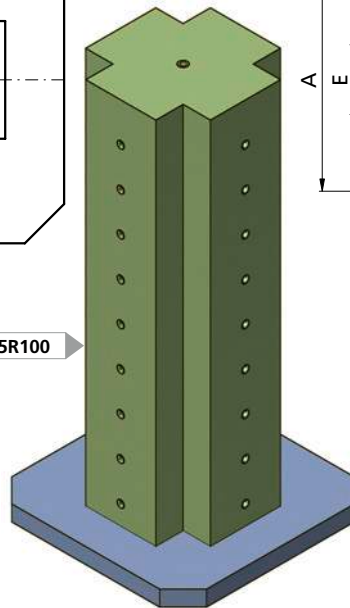
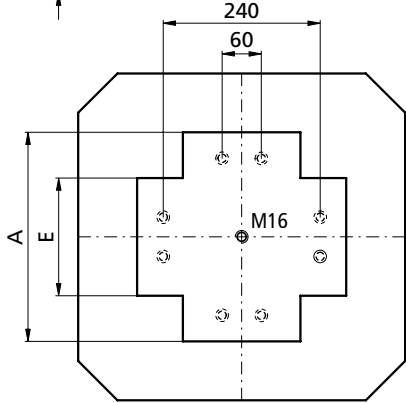
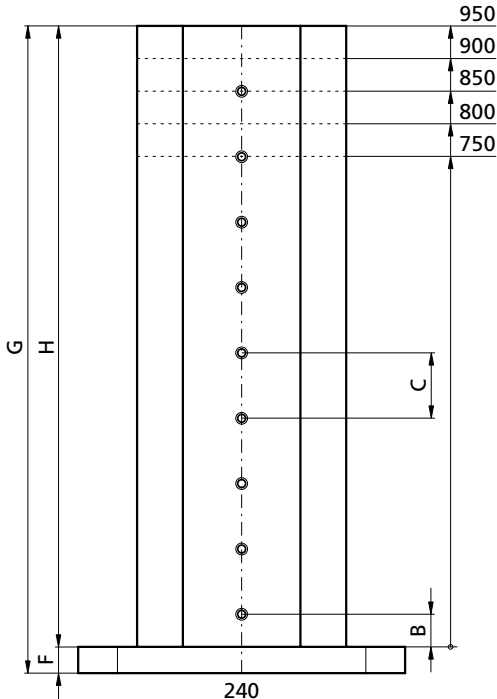

MK321895R100

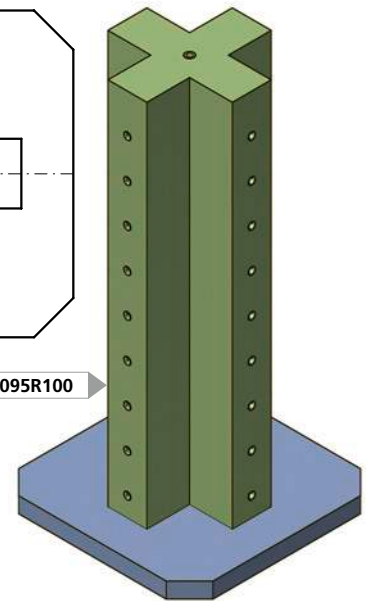
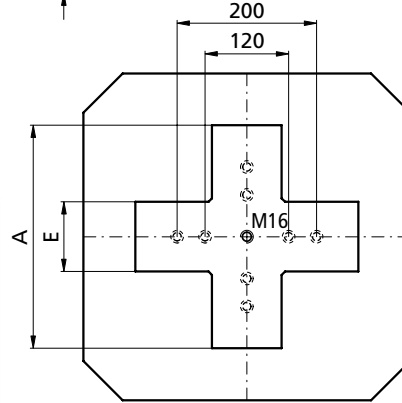
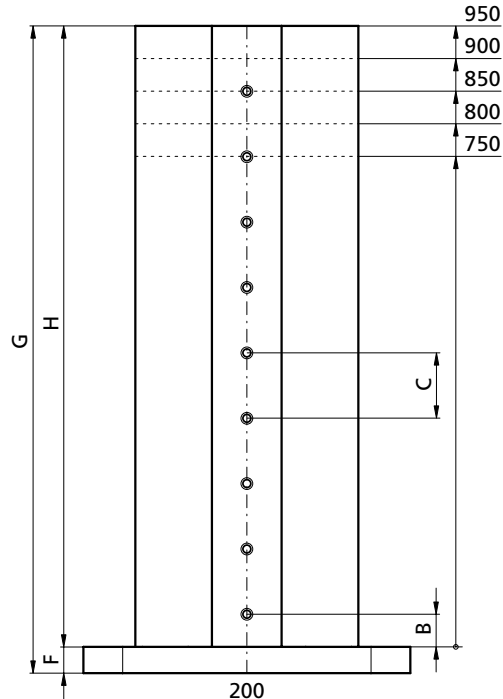

MK321095R100

Grundplatte wird passend zu Ihrer Maschinenpalette hergestellt und muss separat bestellt werden!
Base plate according to your machine configuration please order extra!

Mineralgussturm mit Stahldübel
Epoxy Mineral with Steel Anchor

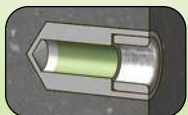

Seite / Page 250

Bestellbeispiel
Ordering example: MK321075R100 & p. 274

| | kg* | A | B | C | E | F | G | H | Raster / Grid |
|--------------|------|-----|----|-----|-----|------|-------|------------|---------------|
| MK321075R100 | ~101 | 320 | 50 | 100 | 100 | (40) | (790) | 750 | 20 x M12/12F7 |
| MK321080R100 | ~108 | 320 | 50 | 100 | 100 | (40) | (840) | 800 | 24 x M12/12F7 |
| MK321085R100 | ~115 | 320 | 50 | 100 | 100 | (40) | (890) | 850 | 28 x M12/12F7 |
| MK321090R100 | ~121 | 320 | 50 | 100 | 100 | (40) | (940) | 900 | 32 x M12/12F7 |
| MK321095R100 | ~128 | 320 | 50 | 100 | 100 | (40) | (990) | 950 | 36 x M12/12F7 |
| MK321875R100 | ~106 | 320 | 50 | 100 | 180 | (40) | (790) | 750 | 20 x M12/12F7 |
| MK321880R100 | ~116 | 320 | 50 | 100 | 180 | (40) | (840) | 800 | 24 x M12/12F7 |
| MK321885R100 | ~126 | 320 | 50 | 100 | 180 | (40) | (890) | 850 | 28 x M12/12F7 |
| MK321890R100 | ~135 | 320 | 50 | 100 | 180 | (40) | (940) | 900 | 32 x M12/12F7 |
| MK321895R100 | ~145 | 320 | 50 | 100 | 180 | (40) | (990) | 950 | 36 x M12/12F7 |

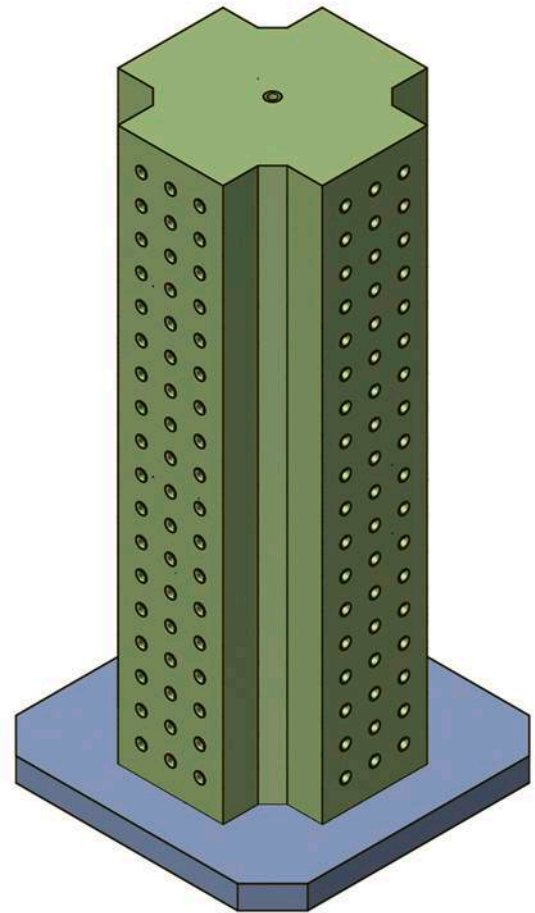
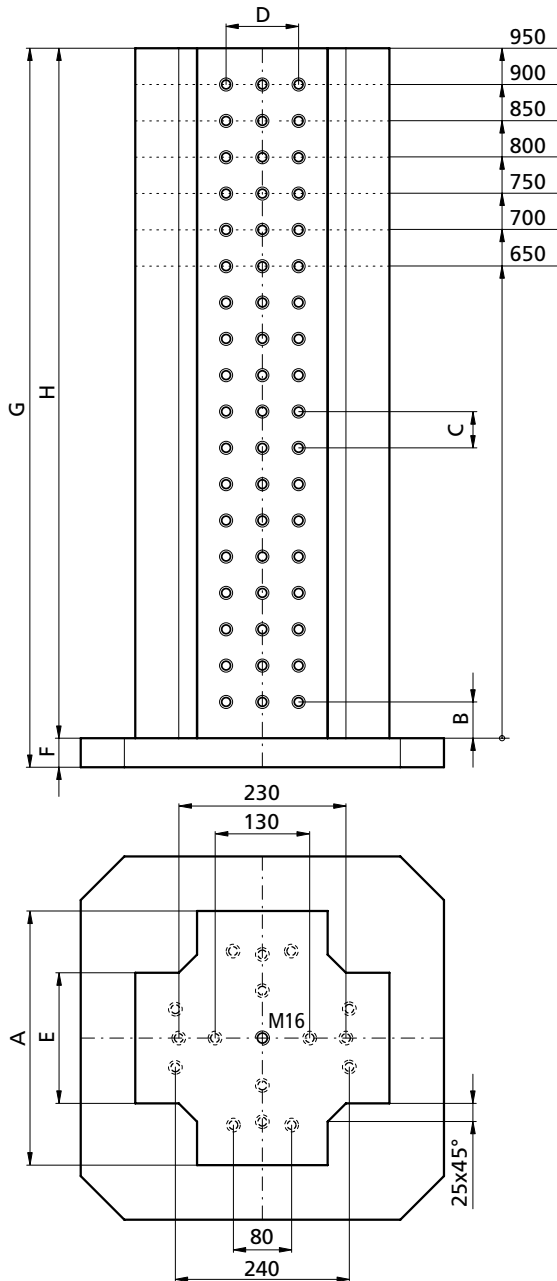

Grundplatte wird passend zu Ihrer Maschinenpalette hergestellt und muss separat bestellt werden!
Base plate according to your machine configuration please order extra!

p. 274

Mineralgussturm mit
Stahldübel
Epoxy Mineral with
Steel Anchor

Stahl-Mineralguss
Steel-epoxy mineral
tombstones

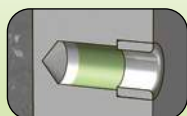
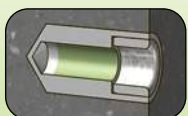

kg*

kg*

Seite / Page 250

Bestellbeispiel
Ordering example: **MK351865R50** &

| | | | | | A | B | C | D | E | F | G | H | Raster / Grid |
|-------------|------|--------------|------|--|-----|----|----|-----|-----|------|-------|------------|----------------|
| MK351865R50 | ~134 | SMK351865R50 | ~165 | | 350 | 50 | 50 | 100 | 180 | (40) | (690) | 650 | 144 x M12/12F7 |
| MK351870R50 | ~144 | SMK351870R50 | ~180 | | 350 | 50 | 50 | 100 | 180 | (40) | (740) | 700 | 156 x M12/12F7 |
| MK351875R50 | ~153 | SMK351875R50 | ~190 | | 350 | 50 | 50 | 100 | 180 | (40) | (790) | 750 | 168 x M12/12F7 |
| MK351880R50 | ~163 | SMK351880R50 | ~205 | | 350 | 50 | 50 | 100 | 180 | (40) | (840) | 800 | 180 x M12/12F7 |
| MK351885R50 | ~172 | SMK351885R50 | ~215 | | 350 | 50 | 50 | 100 | 180 | (40) | (890) | 850 | 192 x M12/12F7 |
| MK351890R50 | ~182 | SMK351890R50 | ~230 | | 350 | 50 | 50 | 100 | 180 | (40) | (940) | 900 | 204 x M12/12F7 |
| MK351895R50 | ~191 | SMK351895R50 | ~240 | | 350 | 50 | 50 | 100 | 180 | (40) | (990) | 950 | 216 x M12/12F7 |

* Gewicht ohne Grundplatte! / Weight without baseplate!

MK4018 ... R50

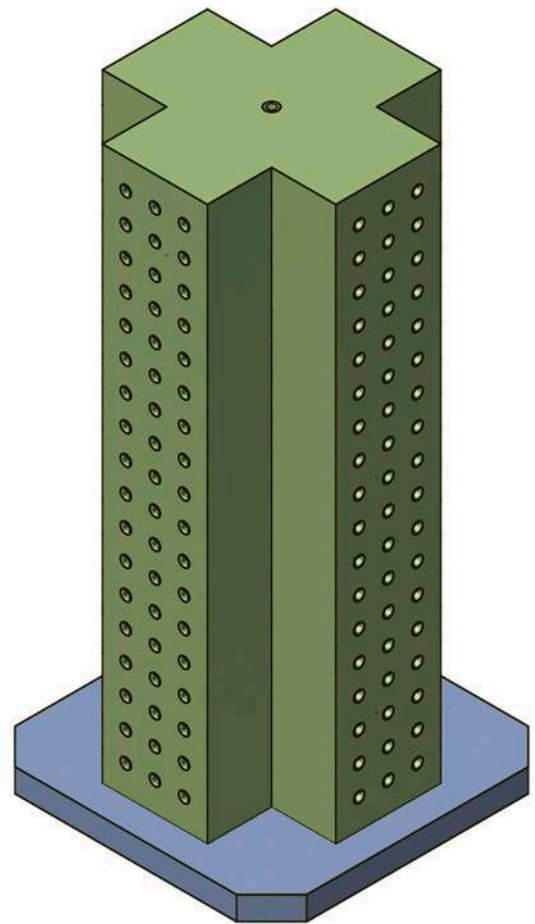
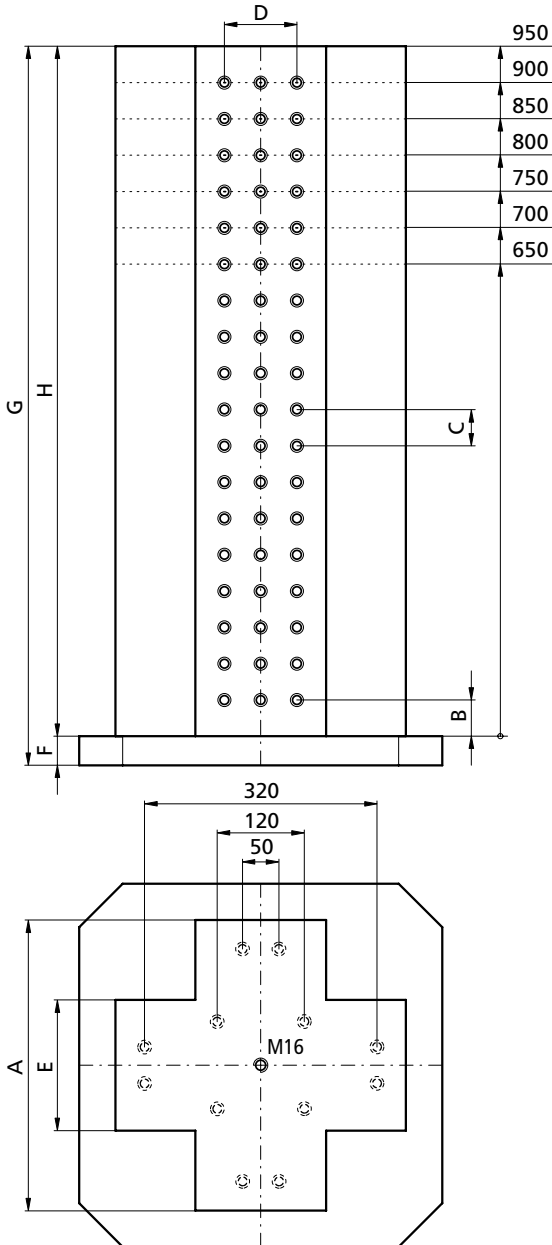

Grundplatte wird passend zu Ihrer Maschinenpalette hergestellt und muss separat bestellt werden!
Base plate according to your machine configuration please order extra!

p. 274

Mineralgussturm mit Stahldübel
Epoxy Mineral with Steel Anchor

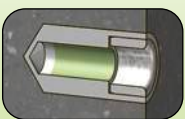

Seite / Page 250

Bestellbeispiel
Ordering example: MK401865R50 &

| | kg* | A | B | C | D | E | F | G | H | Raster / Grid |
|-------------|------|-----|----|----|-----|-----|------|-------|------------|----------------|
| MK401865R50 | ~161 | 400 | 50 | 50 | 100 | 180 | (40) | (690) | 650 | 144 x M12/12F7 |
| MK401870R50 | ~172 | 400 | 50 | 50 | 100 | 180 | (40) | (740) | 700 | 156 x M12/12F7 |
| MK401875R50 | ~184 | 400 | 50 | 50 | 100 | 180 | (40) | (790) | 750 | 168 x M12/12F7 |
| MK401880R50 | ~195 | 400 | 50 | 50 | 100 | 180 | (40) | (840) | 800 | 180 x M12/12F7 |
| MK401885R50 | ~207 | 400 | 50 | 50 | 100 | 180 | (40) | (890) | 850 | 192 x M12/12F7 |
| MK401890R50 | ~218 | 400 | 50 | 50 | 100 | 180 | (40) | (940) | 900 | 204 x M12/12F7 |
| MK401895R50 | ~230 | 400 | 50 | 50 | 100 | 180 | (40) | (990) | 950 | 216 x M12/12F7 |

* Gewicht ohne Grundplatte! / Weight without baseplate!

| Art. Nr. | kg | Raster / Grid | H |
|--------------------|-----|---------------|-----|
| MQ161630R50 | ~19 | 20 x M12/12F7 | 300 |
| MQ161635R50 | ~22 | 24 x M12/12F7 | 350 |
| MQ161640R50 | ~25 | 28 x M12/12F7 | 400 |
| MQ161645R50 | ~28 | 32 x M12/12F7 | 450 |
| MQ161650R50 | ~31 | 36 x M12/12F7 | 500 |

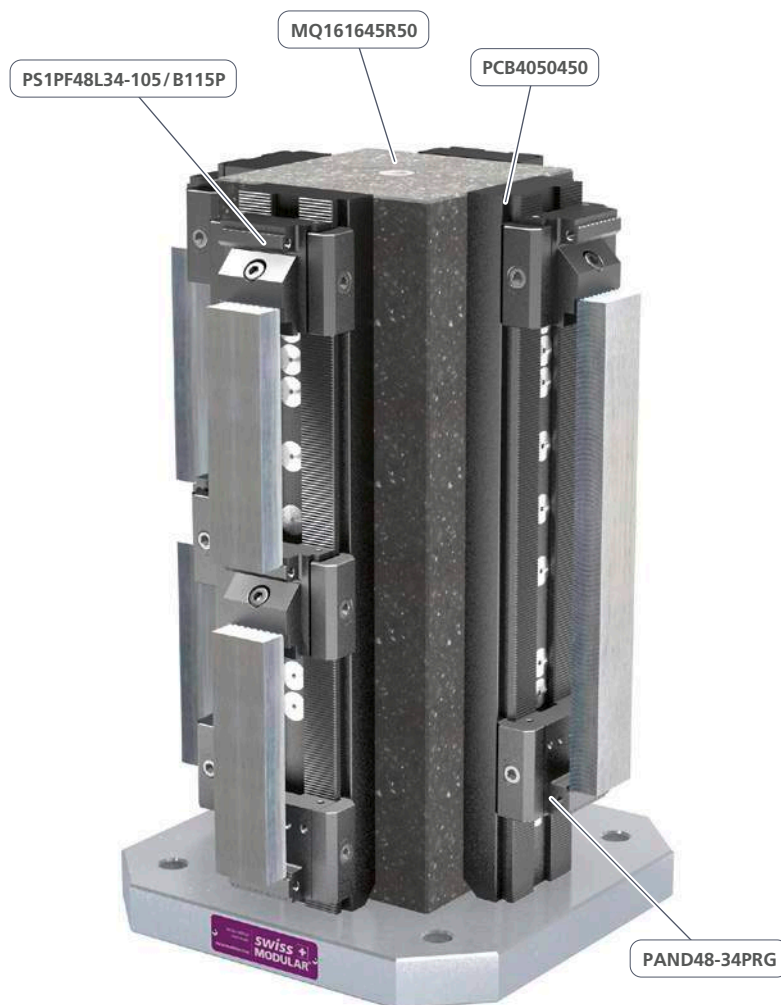
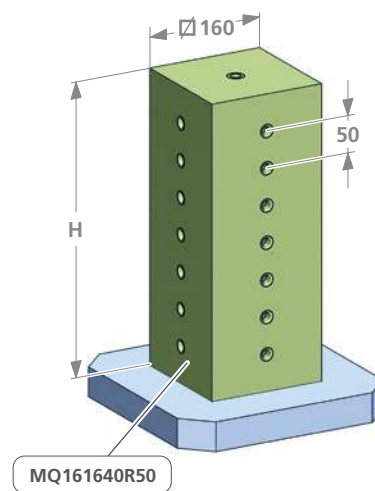

*Maschinenschonend und leicht,
fast in allen Formen herstellbar.*

*Reduces machine wear due to low
specific weight - can be produced in
all sorts of shapes.*

| Art. Nr. | kg | Raster / Grid | H |
|--------------------|------|----------------|-----|
| MQ202040R50 | ~42 | 84 x M12/12F7 | 400 |
| MQ202045R50 | ~53 | 96 x M12/12F7 | 450 |
| MQ202050R50 | ~59 | 108 x M12/12F7 | 500 |
| MQ202055R50 | ~64 | 120 x M12/12F7 | 550 |
| MQ202060R50 | ~70 | 132 x M12/12F7 | 600 |
| MQ202065R50 | ~76 | 144 x M12/12F7 | 650 |
| MQ202070R50 | ~81 | 156 x M12/12F7 | 700 |
| MQ242450R50 | ~81 | 108 x M12/12F7 | 500 |
| MQ242455R50 | ~89 | 120 x M12/12F7 | 550 |
| MQ242460R50 | ~97 | 132 x M12/12F7 | 600 |
| MQ242465R50 | ~103 | 144 x M12/12F7 | 650 |

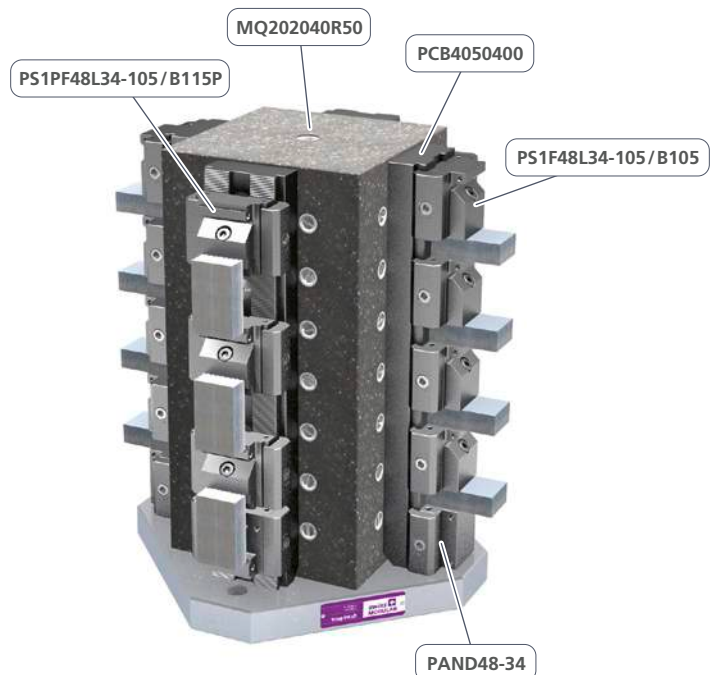
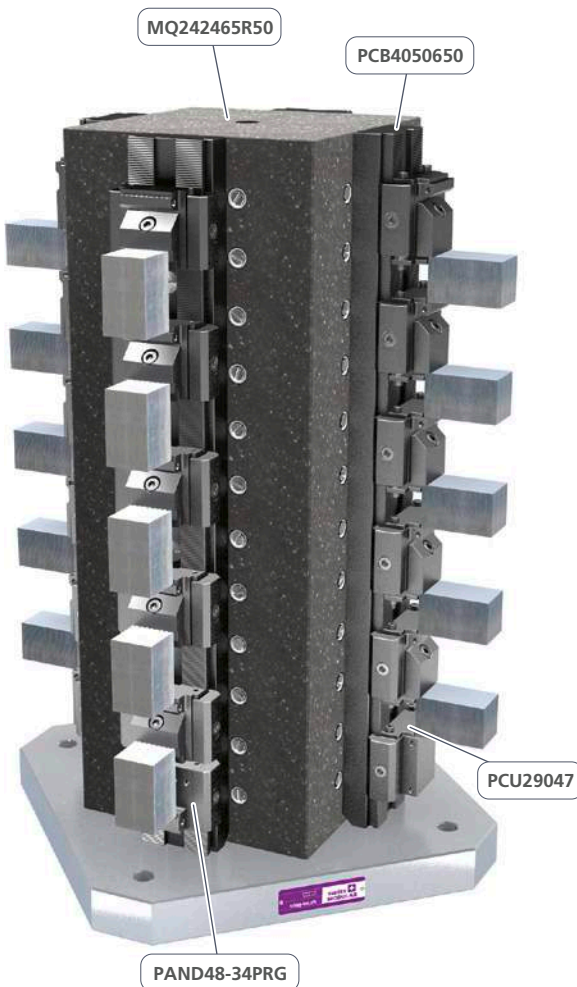
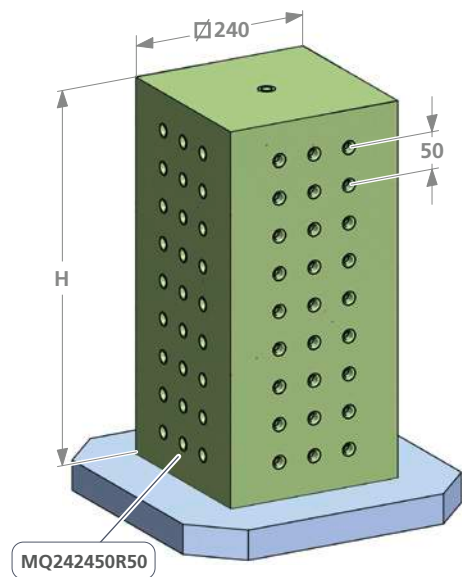
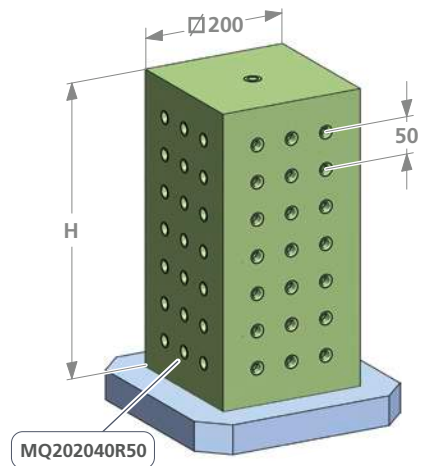

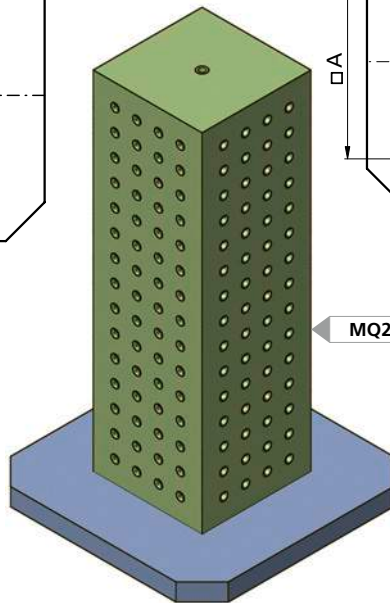
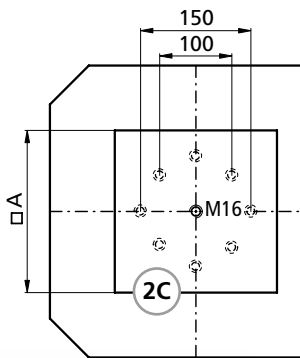
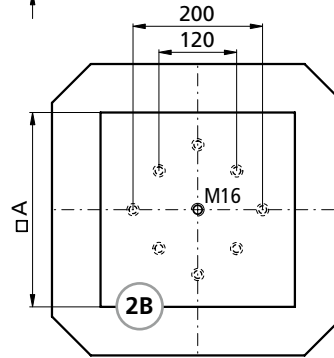
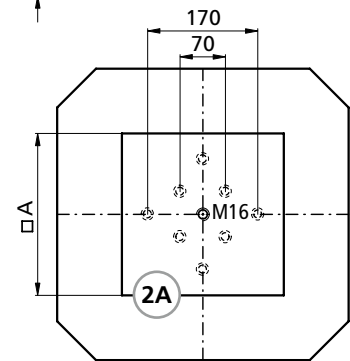
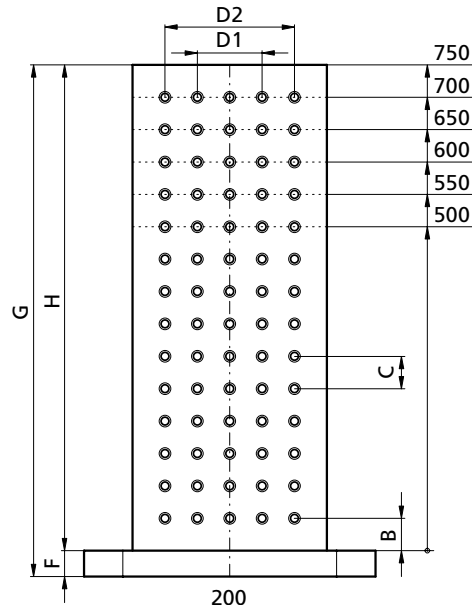
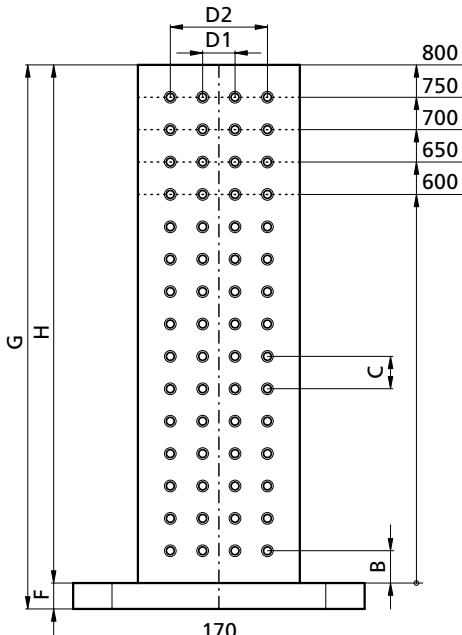

MQ303075R50

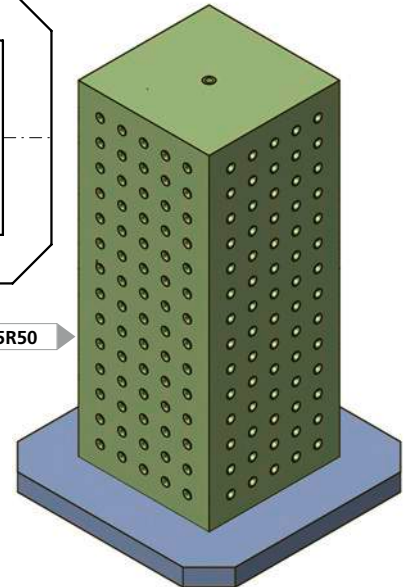

Grundplatte wird passend zu Ihrer Maschinenpalette hergestellt und muss separat bestellt werden!
Base plate according to your machine configuration please order extra!

p. 274

Mineralgussturm mit
Stahldübel
Epoxy Mineral with
Steel Anchor

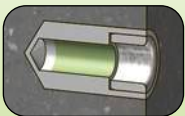

Seite / Page 250

Bestellbeispiel
Ordering example: MQ252560R50 &

| kg* | Bohrbild Hole pattern | A | B | C | D1 | D2 | F | G | H | Raster / Grid | |
|-------------|--------------------------|----|-----|----|----|-----|-----|------|-------|---------------|----------------|
| MQ252560R50 | ~107 | 2A | 250 | 50 | 50 | 100 | 150 | (40) | (640) | 600 | 176 x M12/12F7 |
| MQ252565R50 | ~116 | 2A | 250 | 50 | 50 | 100 | 150 | (40) | (690) | 650 | 192 x M12/12F7 |
| MQ252570R50 | ~125 | 2A | 250 | 50 | 50 | 100 | 150 | (40) | (740) | 700 | 208 x M12/12F7 |
| MQ252575R50 | ~134 | 2C | 250 | 50 | 50 | 100 | 150 | (40) | (790) | 750 | 224 x M12/12F7 |
| MQ252580R50 | ~143 | 2C | 250 | 50 | 50 | 100 | 150 | (40) | (840) | 800 | 240 x M12/12F7 |
| MQ303050R50 | ~109 | 2B | 300 | 50 | 50 | 100 | 200 | (40) | (540) | 500 | 180 x M12/12F7 |
| MQ303055R50 | ~119 | 2B | 300 | 50 | 50 | 100 | 200 | (40) | (590) | 550 | 200 x M12/12F7 |
| MQ303060R50 | ~129 | 2B | 300 | 50 | 50 | 100 | 200 | (40) | (640) | 600 | 220 x M12/12F7 |
| MQ303065R50 | ~139 | 2B | 300 | 50 | 50 | 100 | 200 | (40) | (690) | 650 | 240 x M12/12F7 |
| MQ303070R50 | ~149 | 2B | 300 | 50 | 50 | 100 | 200 | (40) | (740) | 700 | 260 x M12/12F7 |
| MQ303075R50 | ~162 | 2B | 300 | 50 | 50 | 100 | 200 | (40) | (790) | 750 | 280 x M12/12F7 |

* Gewicht ohne Grundplatte! / Weight without baseplate!

MQ4040 ... R50
MQ3535 ... R50



tripoxyMINERAL

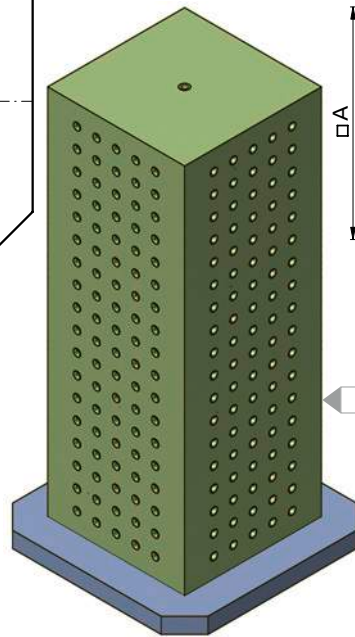
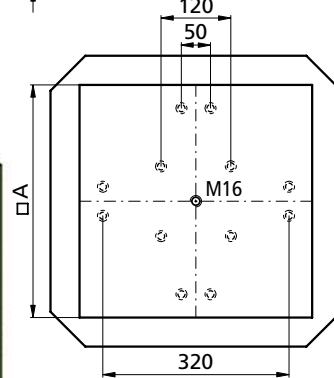
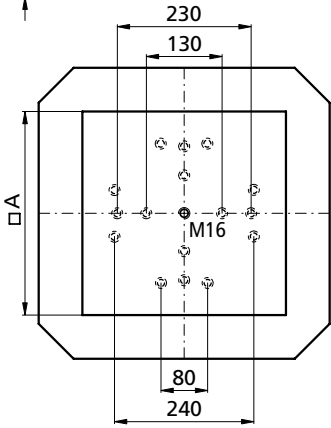
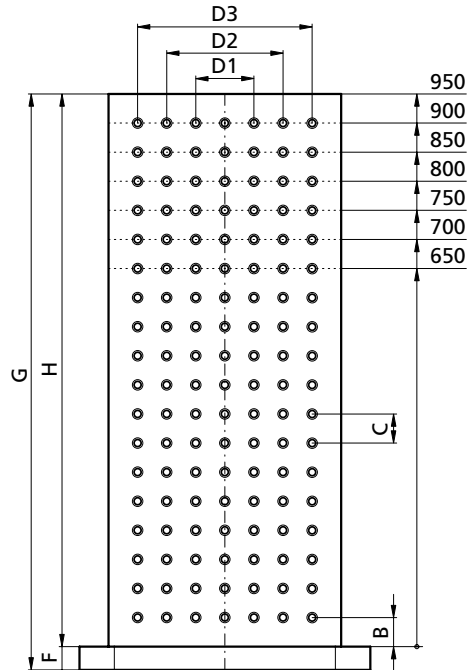
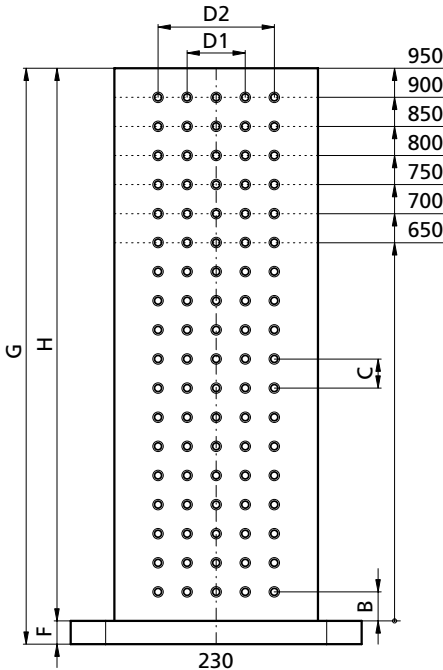

MQ404095R50

MQ353595R50

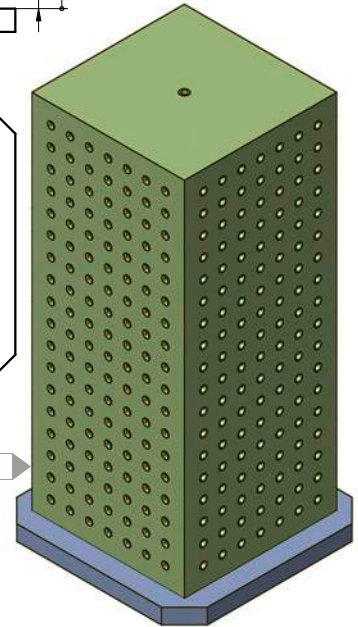

Grundplatte wird passend zu Ihrer Maschinenpalette hergestellt und muss separat bestellt werden!
Base plate according to your machine configuration please order extra!

Mineralgussturm mit Stahldübel
Epoxy Mineral with Steel Anchor

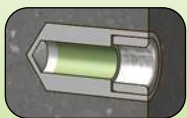

Seite / Page 250

Bestellbeispiel
Ordering example: MQ353565R50 & _____ p. 274

| | kg* | A | B | C | D1 | D2 | D3 | F | G | H | Raster / Grid |
|-------------|------|-----|----|----|-----|-----|-----|------|-------|------------|----------------|
| MQ353565R50 | ~175 | 350 | 50 | 50 | 100 | 200 | | (40) | (690) | 650 | 240 x M12/12F7 |
| MQ353570R50 | ~187 | 350 | 50 | 50 | 100 | 200 | | (40) | (740) | 700 | 260 x M12/12F7 |
| MQ353575R50 | ~200 | 350 | 50 | 50 | 100 | 200 | | (40) | (790) | 750 | 280 x M12/12F7 |
| MQ353580R50 | ~213 | 350 | 50 | 50 | 100 | 200 | | (40) | (840) | 800 | 300 x M12/12F7 |
| MQ353585R50 | ~225 | 350 | 50 | 50 | 100 | 200 | | (40) | (890) | 850 | 320 x M12/12F7 |
| MQ353590R50 | ~238 | 350 | 50 | 50 | 100 | 200 | | (40) | (940) | 900 | 340 x M12/12F7 |
| MQ353595R50 | ~250 | 350 | 50 | 50 | 100 | 200 | | (40) | (990) | 950 | 360 x M12/12F7 |
| MQ404065R50 | ~217 | 400 | 50 | 50 | 100 | 200 | 300 | (40) | (690) | 650 | 336 x M12/12F7 |
| MQ404070R50 | ~232 | 400 | 50 | 50 | 100 | 200 | 300 | (40) | (740) | 700 | 364 x M12/12F7 |
| MQ404075R50 | ~247 | 400 | 50 | 50 | 100 | 200 | 300 | (40) | (790) | 750 | 392 x M12/12F7 |
| MQ404080R50 | ~262 | 400 | 50 | 50 | 100 | 200 | 300 | (40) | (840) | 800 | 420 x M12/12F7 |
| MQ404085R50 | ~277 | 400 | 50 | 50 | 100 | 200 | 300 | (40) | (890) | 850 | 448 x M12/12F7 |
| MQ404090R50 | ~292 | 400 | 50 | 50 | 100 | 200 | 300 | (40) | (940) | 900 | 476 x M12/12F7 |
| MQ404095R50 | ~307 | 400 | 50 | 50 | 100 | 200 | 300 | (40) | (990) | 950 | 504 x M12/12F7 |

* Gewicht ohne Grundplatte! / Weight without baseplate!

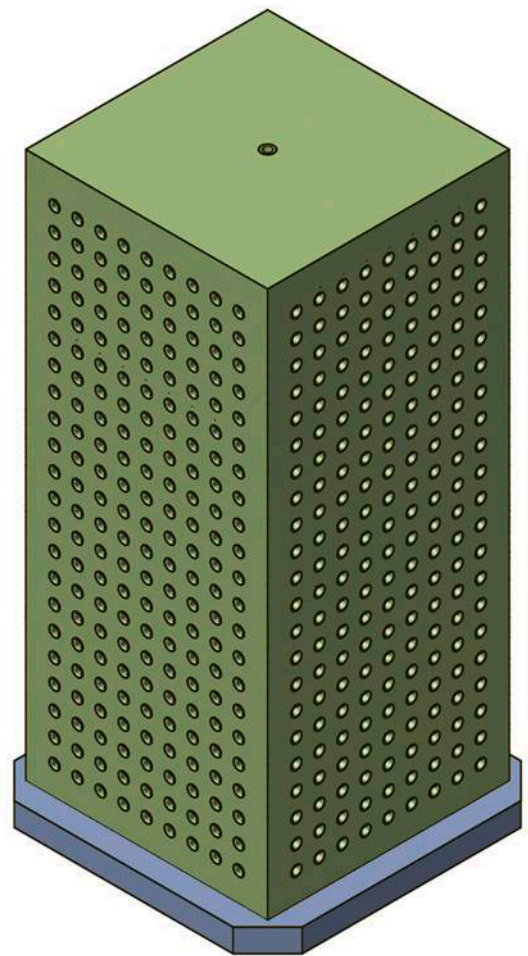
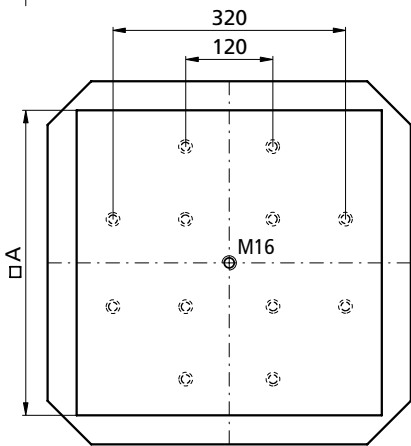
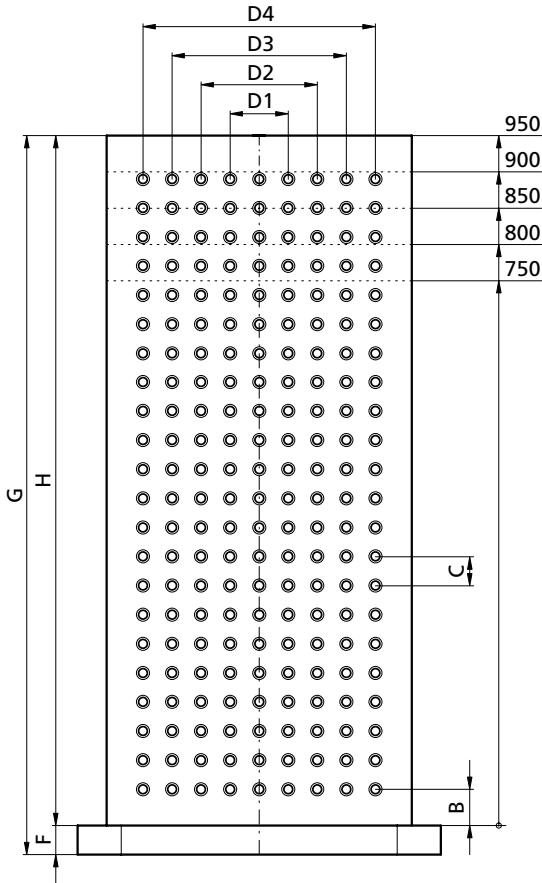

Grundplatte wird passend zu Ihrer Maschinenpalette hergestellt und muss separat bestellt werden!
Base plate according to your machine configuration please order extra!

Mineralgussturm mit Stahldübel
Epoxy Mineral with Steel Anchor

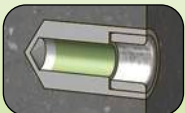

Seite / Page 250

Bestellbeispiel
Ordering example: MQ424275R40 & _____ p. 274

| | kg* | A | B | C | D1 | D2 | D3 | D4 | F | G | H | Raster / Grid |
|-------------|------|-----|----|----|----|-----|-----|-----|------|-------|------------|----------------|
| MQ424275R40 | ~329 | 420 | 50 | 40 | 80 | 160 | 240 | 320 | (40) | (790) | 750 | 612 x M12/12F7 |
| MQ424280R40 | ~349 | 420 | 50 | 40 | 80 | 160 | 240 | 320 | (40) | (840) | 800 | 648 x M12/12F7 |
| MQ424285R40 | ~373 | 420 | 50 | 40 | 80 | 160 | 240 | 320 | (40) | (890) | 850 | 684 x M12/12F7 |
| MQ424290R40 | ~393 | 420 | 50 | 40 | 80 | 160 | 240 | 320 | (40) | (940) | 900 | 720 x M12/12F7 |
| MQ424295R40 | ~413 | 420 | 50 | 40 | 80 | 160 | 240 | 320 | (40) | (990) | 950 | 756 x M12/12F7 |

* Gewicht ohne Grundplatte! / Weight without baseplate!

Separat bestellen / Order separately

MR3015 ... R50

MR4012 ... R50

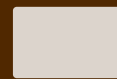

Rechteck
Rectangle

tripoxyMINERAL

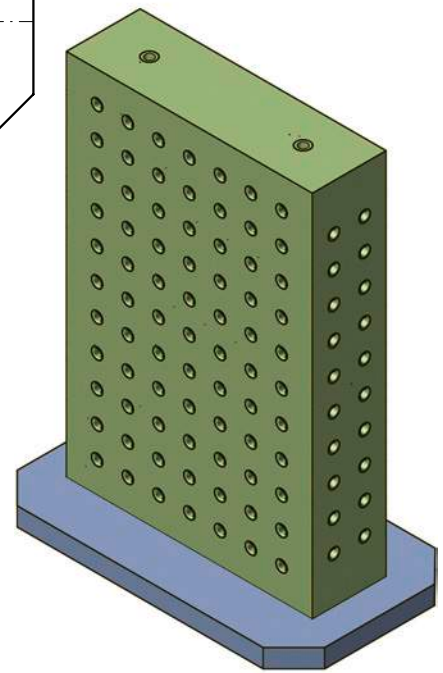
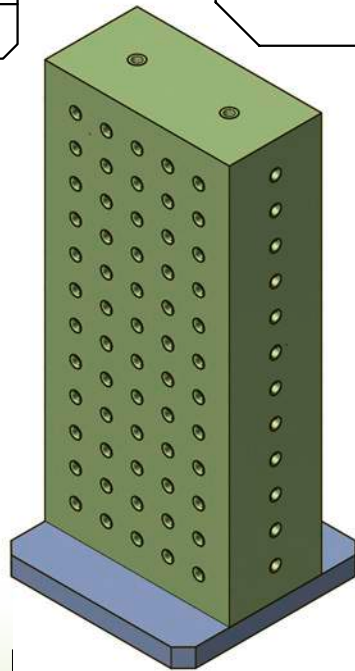
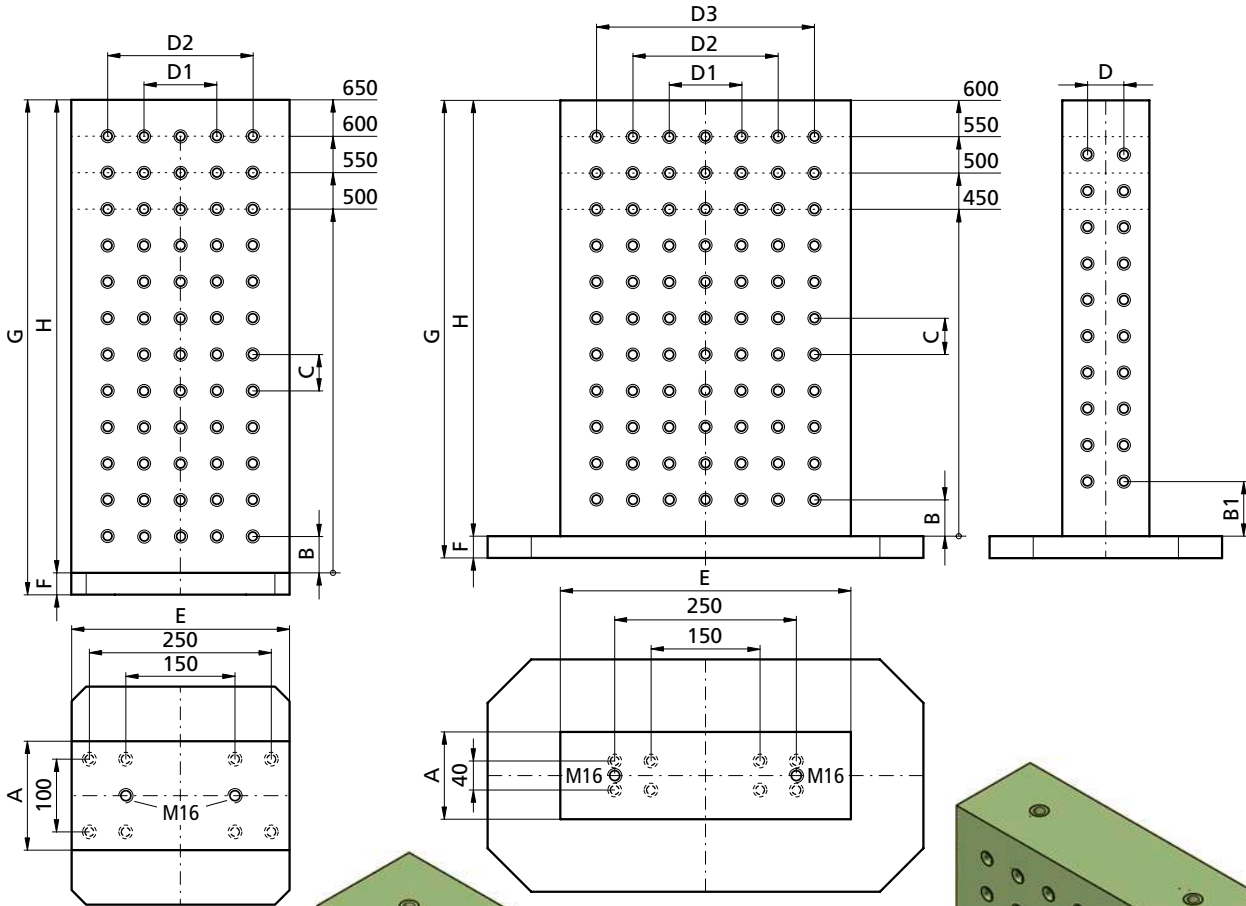

Mineralgussturm mit
Stahldübel
Epoxy Mineral with
Steel Anchor

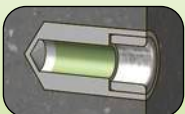

Seite / Page 250

Bestellbeispiel

Ordering example: **MR401245R50** &

p. 274

Grundplatte wird passend
zu Ihrer Maschinenpalette
hergestellt und muss separat
bestellt werden!

Base plate according to your
machine configuration please
order extra!

| | kg* | A | B | B1 | C | D | D1 | D2 | D3 | E | F | G | H | Raster / Grid |
|-------------|-----|-----|----|----|----|----|-----|-----|-----|-----|------|-------|-----|----------------|
| MR301550R50 | ~65 | 150 | 50 | | 50 | | 100 | 200 | | 300 | (30) | (530) | 500 | 63 x M12/12F7 |
| MR301555R50 | ~72 | 150 | 50 | | 50 | | 100 | 200 | | 300 | (30) | (580) | 550 | 70 x M12/12F7 |
| MR301560R50 | ~78 | 150 | 50 | | 50 | | 100 | 200 | | 300 | (30) | (630) | 600 | 77 x M12/12F7 |
| MR301565R50 | ~85 | 150 | 50 | | 50 | | 100 | 200 | | 300 | (30) | (680) | 650 | 84 x M12/12F7 |
| MR401245R50 | ~64 | 120 | 50 | 75 | 50 | 50 | 100 | 200 | 300 | 400 | (30) | (480) | 450 | 140 x M12/12F7 |
| MR401250R50 | ~71 | 120 | 50 | 75 | 50 | 50 | 100 | 200 | 300 | 400 | (30) | (530) | 500 | 158 x M12/12F7 |
| MR401255R50 | ~78 | 120 | 50 | 75 | 50 | 50 | 100 | 200 | 300 | 400 | (30) | (580) | 550 | 176 x M12/12F7 |
| MR401260R50 | ~85 | 120 | 50 | 75 | 50 | 50 | 100 | 200 | 300 | 400 | (30) | (630) | 600 | 194 x M12/12F7 |



Rechteck
Rectangle

MR4020 ... R50

tripoxyMINERAL

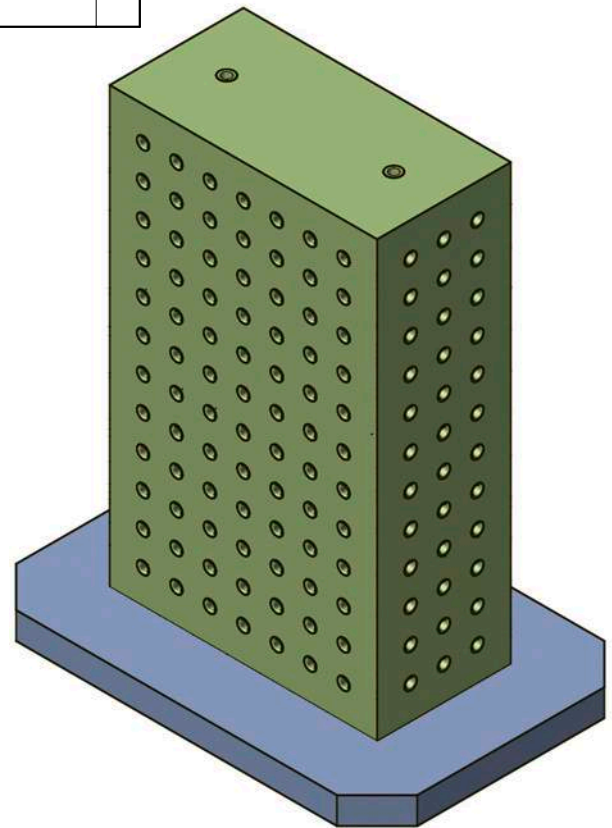
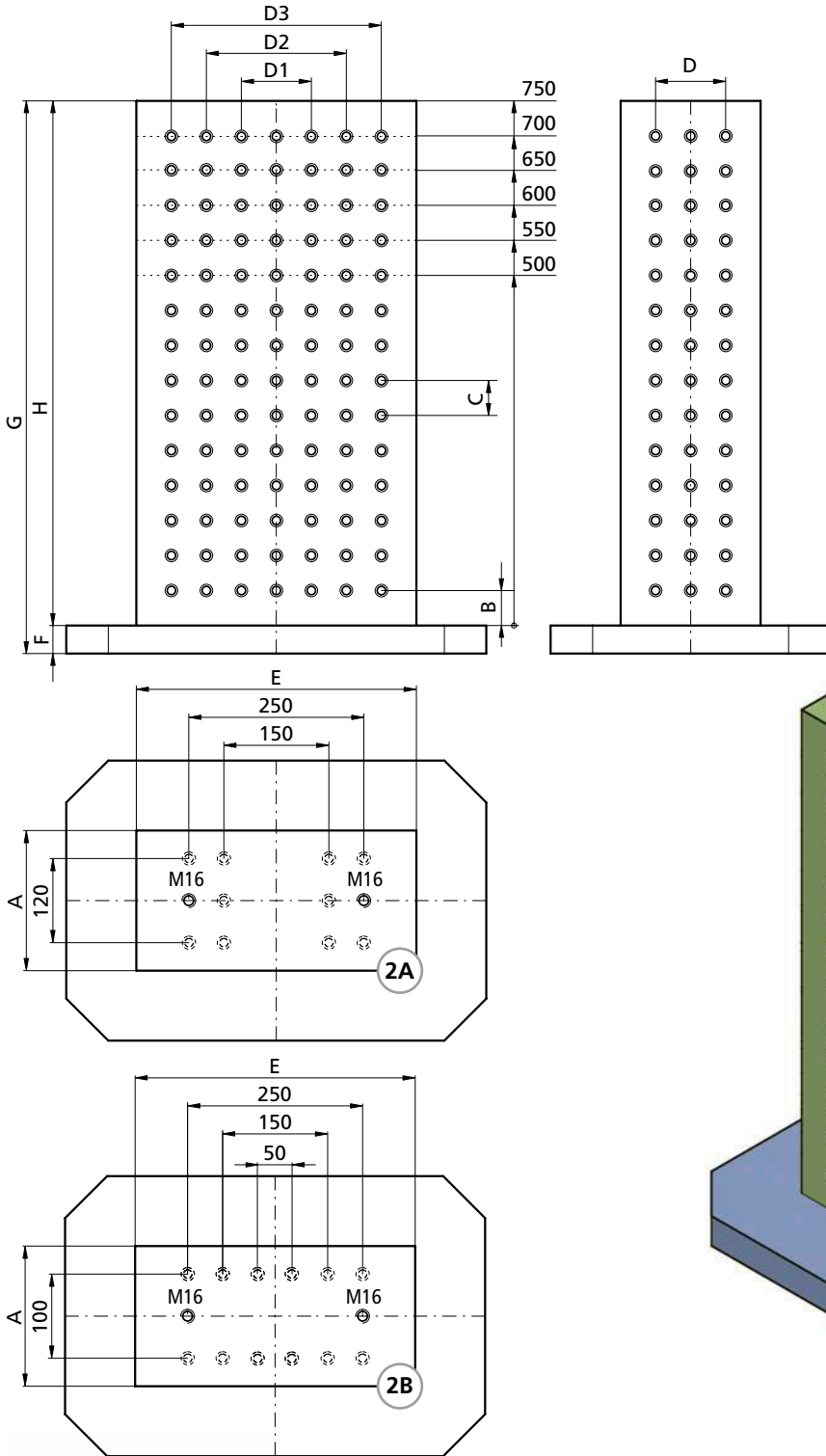

Grundplatte wird passend zu Ihrer Maschinenpalette hergestellt und muss separat bestellt werden!
Base plate according to your machine configuration please order extra!

Mineralgussturm mit Stahldübel
Epoxy Mineral with Steel Anchor

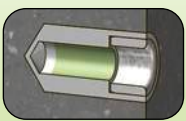

Seite / Page 250

Bestellbeispiel

Ordering example: **MR402050R50** & _____ p. 274

| | kg* | Bohrbild / Hole pattern | A | B | C | D | D1 | D2 | D3 | E | F | G | H | Raster / Grid |
|-------------|------|-------------------------|-----|----|----|-----|-----|-----|-----|-----|------|-------|-----|----------------|
| MR402050R50 | ~115 | 2A | 200 | 50 | 50 | 100 | 100 | 200 | 300 | 400 | (40) | (540) | 500 | 180 x M12/12F7 |
| MR402055R50 | ~126 | 2A | 200 | 50 | 50 | 100 | 100 | 200 | 300 | 400 | (40) | (590) | 550 | 200 x M12/12F7 |
| MR402060R50 | ~138 | 2A | 200 | 50 | 50 | 100 | 100 | 200 | 300 | 400 | (40) | (640) | 600 | 220 x M12/12F7 |
| MR402065R50 | ~149 | 2A | 200 | 50 | 50 | 100 | 100 | 200 | 300 | 400 | (40) | (690) | 650 | 240 x M12/12F7 |
| MR402070R50 | ~162 | 2B | 200 | 50 | 50 | 100 | 100 | 200 | 300 | 400 | (40) | (740) | 700 | 260 x M12/12F7 |
| MR402075R50 | ~172 | 2B | 200 | 50 | 50 | 100 | 100 | 200 | 300 | 400 | (40) | (790) | 750 | 280 x M12/12F7 |

* Gewicht ohne Grundplatte! / Weight without baseplate!

MR5020 ... R50-2

MR5020 ... R50-4

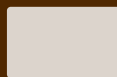

Rechteck
Rectangle

tripoxyMINERAL

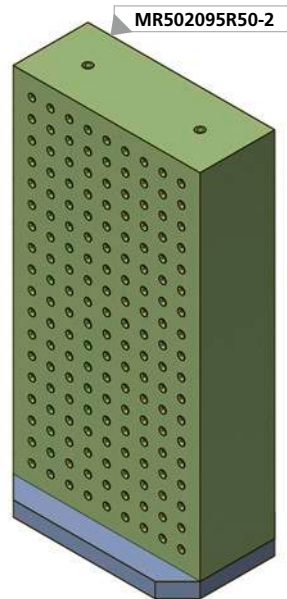
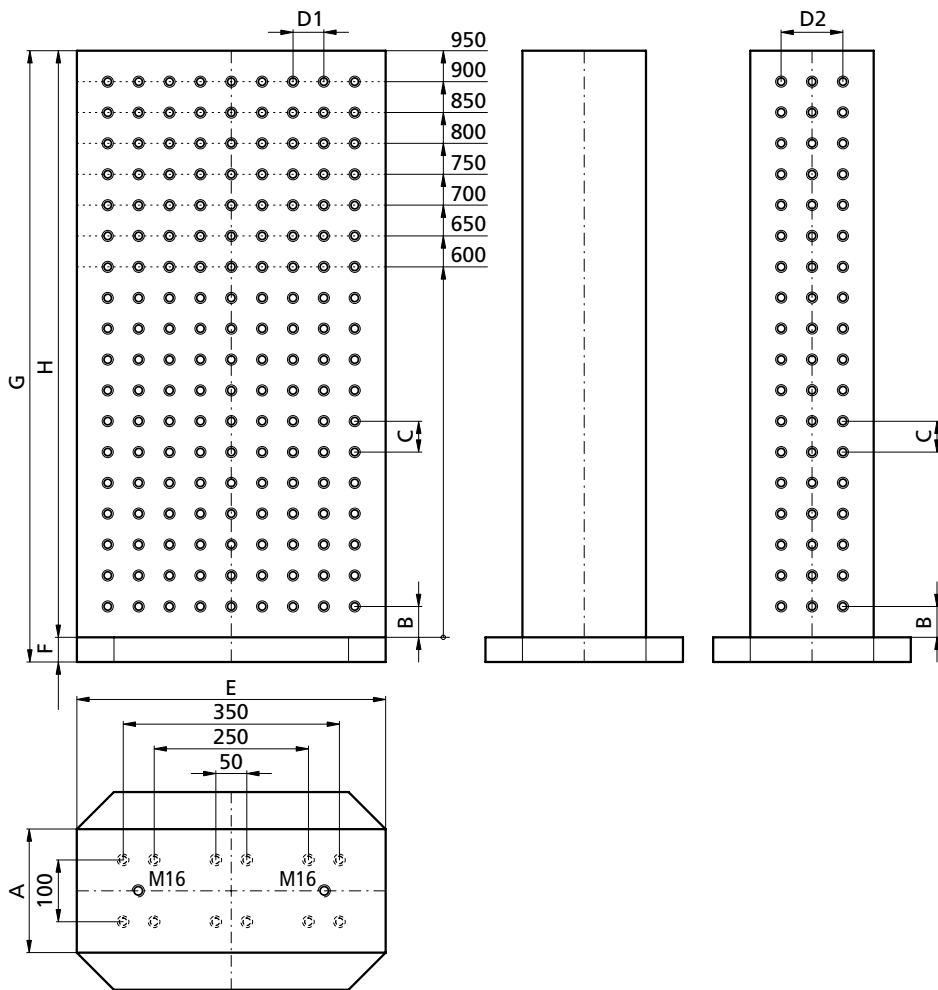

MR502095R50-2

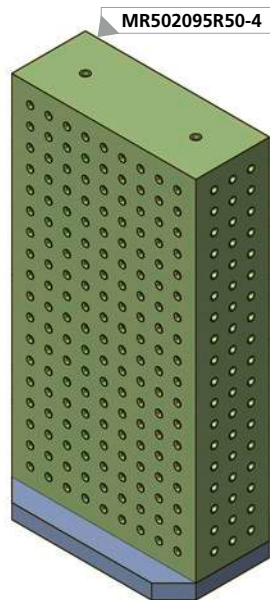

MR502095R50-4

Mineralgussturm mit
Stahldübel
Epoxy Mineral with
Steel Anchor

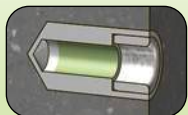

Seite / Page 250

Bestellbeispiel

Ordering example: **MR502060R50-2** & _____ p. 274

Grundplatte wird passend
zu Ihrer Maschinenpalette
hergestellt und muss separat
bestellt werden!
Base plate according to your
machine configuration please
order extra!

| | kg* | A | B | C | D1 | D2 | E | F | G | H | Raster / Grid |
|---------------|------|-----|----|----|----|-----|-----|------|-------|-----|----------------|
| MR502060R50-2 | ~165 | 200 | 50 | 50 | 50 | | 500 | (40) | (640) | 600 | 198 x M12/12F7 |
| MR502065R50-2 | ~179 | 200 | 50 | 50 | 50 | | 500 | (40) | (690) | 650 | 216 x M12/12F7 |
| MR502070R50-2 | ~193 | 200 | 50 | 50 | 50 | | 500 | (40) | (740) | 700 | 234 x M12/12F7 |
| MR502075R50-2 | ~208 | 200 | 50 | 50 | 50 | | 500 | (40) | (790) | 750 | 252 x M12/12F7 |
| MR502080R50-2 | ~222 | 200 | 50 | 50 | 50 | | 500 | (40) | (840) | 800 | 270 x M12/12F7 |
| MR502085R50-2 | ~236 | 200 | 50 | 50 | 50 | | 500 | (40) | (890) | 850 | 288 x M12/12F7 |
| MR502090R50-2 | ~251 | 200 | 50 | 50 | 50 | | 500 | (40) | (940) | 900 | 306 x M12/12F7 |
| MR502095R50-2 | ~265 | 200 | 50 | 50 | 50 | | 500 | (40) | (990) | 950 | 324 x M12/12F7 |
| MR502060R50-4 | ~171 | 200 | 50 | 50 | 50 | 100 | 500 | (40) | (640) | 600 | 264 x M12/12F7 |
| MR502065R50-4 | ~185 | 200 | 50 | 50 | 50 | 100 | 500 | (40) | (690) | 650 | 288 x M12/12F7 |
| MR502070R50-4 | ~199 | 200 | 50 | 50 | 50 | 100 | 500 | (40) | (740) | 700 | 312 x M12/12F7 |
| MR502075R50-4 | ~214 | 200 | 50 | 50 | 50 | 100 | 500 | (40) | (790) | 750 | 336 x M12/12F7 |
| MR502080R50-4 | ~228 | 200 | 50 | 50 | 50 | 100 | 500 | (40) | (840) | 800 | 360 x M12/12F7 |
| MR502085R50-4 | ~242 | 200 | 50 | 50 | 50 | 100 | 500 | (40) | (890) | 850 | 384 x M12/12F7 |
| MR502090R50-4 | ~257 | 200 | 50 | 50 | 50 | 100 | 500 | (40) | (940) | 900 | 408 x M12/12F7 |
| MR502095R50-4 | ~271 | 200 | 50 | 50 | 50 | 100 | 500 | (40) | (990) | 950 | 432 x M12/12F7 |

MR6020 ... R50-2

MR6020 ... R50-4

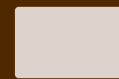

Rechteck
Rectangle

tripoxyMINERAL

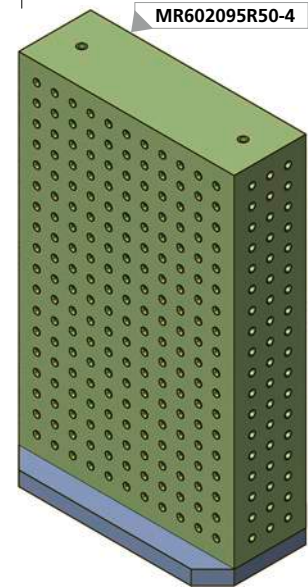
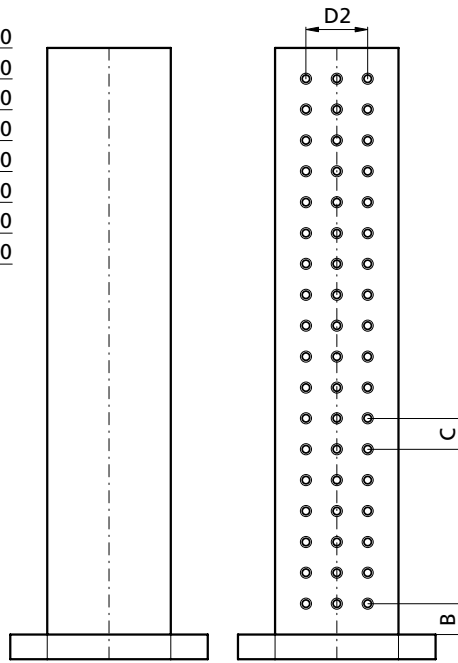
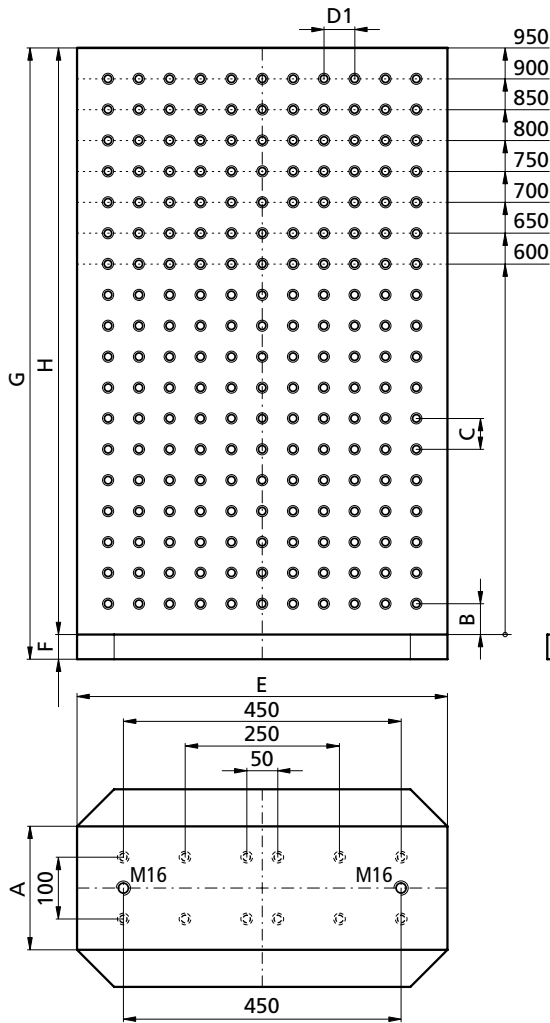

Mineralgussturm mit
Stahldübel
Epoxy Mineral with
Steel Anchor

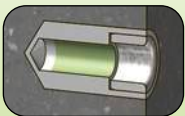

Seite / Page 250

Bestellbeispiel

Ordering example: MR602060R50-2 & p. 274

Grundplatte wird passend
zu Ihrer Maschinenpalette
hergestellt und muss separat
bestellt werden!
Base plate according to your
machine configuration please
order extra!

| | kg* | A | B | C | D1 | D2 | E | F | G | H | Raster / Grid |
|---------------|------|-----|----|----|----|-----|-----|------|-------|-----|----------------|
| MR602060R50-2 | ~200 | 200 | 50 | 50 | 50 | | 600 | (40) | (640) | 600 | 242 x M12/12F7 |
| MR602065R50-2 | ~217 | 200 | 50 | 50 | 50 | | 600 | (40) | (690) | 650 | 264 x M12/12F7 |
| MR602070R50-2 | ~234 | 200 | 50 | 50 | 50 | | 600 | (40) | (740) | 700 | 286 x M12/12F7 |
| MR602075R50-2 | ~250 | 200 | 50 | 50 | 50 | | 600 | (40) | (790) | 750 | 308 x M12/12F7 |
| MR602080R50-2 | ~267 | 200 | 50 | 50 | 50 | | 600 | (40) | (840) | 800 | 330 x M12/12F7 |
| MR602085R50-2 | ~284 | 200 | 50 | 50 | 50 | | 600 | (40) | (890) | 850 | 352 x M12/12F7 |
| MR602090R50-2 | ~301 | 200 | 50 | 50 | 50 | | 600 | (40) | (940) | 900 | 374 x M12/12F7 |
| MR602095R50-2 | ~317 | 200 | 50 | 50 | 50 | | 600 | (40) | (990) | 950 | 396 x M12/12F7 |
| MR602060R50-4 | ~205 | 200 | 50 | 50 | 50 | 100 | 600 | (40) | (640) | 600 | 308 x M12/12F7 |
| MR602065R50-4 | ~222 | 200 | 50 | 50 | 50 | 100 | 600 | (40) | (690) | 650 | 330 x M12/12F7 |
| MR602070R50-4 | ~239 | 200 | 50 | 50 | 50 | 100 | 600 | (40) | (740) | 700 | 364 x M12/12F7 |
| MR602075R50-4 | ~256 | 200 | 50 | 50 | 50 | 100 | 600 | (40) | (790) | 750 | 392 x M12/12F7 |
| MR602080R50-4 | ~273 | 200 | 50 | 50 | 50 | 100 | 600 | (40) | (840) | 800 | 420 x M12/12F7 |
| MR602085R50-4 | ~290 | 200 | 50 | 50 | 50 | 100 | 600 | (40) | (890) | 850 | 448 x M12/12F7 |
| MR602090R50-4 | ~307 | 200 | 50 | 50 | 50 | 100 | 600 | (40) | (940) | 900 | 476 x M12/12F7 |
| MR602095R50-4 | ~324 | 200 | 50 | 50 | 50 | 100 | 600 | (40) | (990) | 950 | 504 x M12/12F7 |

* Gewicht ohne Grundplatte! / Weight without baseplate!

Separat bestellen / Order separately

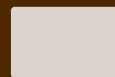

Rechteck
Rectangle

MR6330 ... R40

tripoxyMINERAL

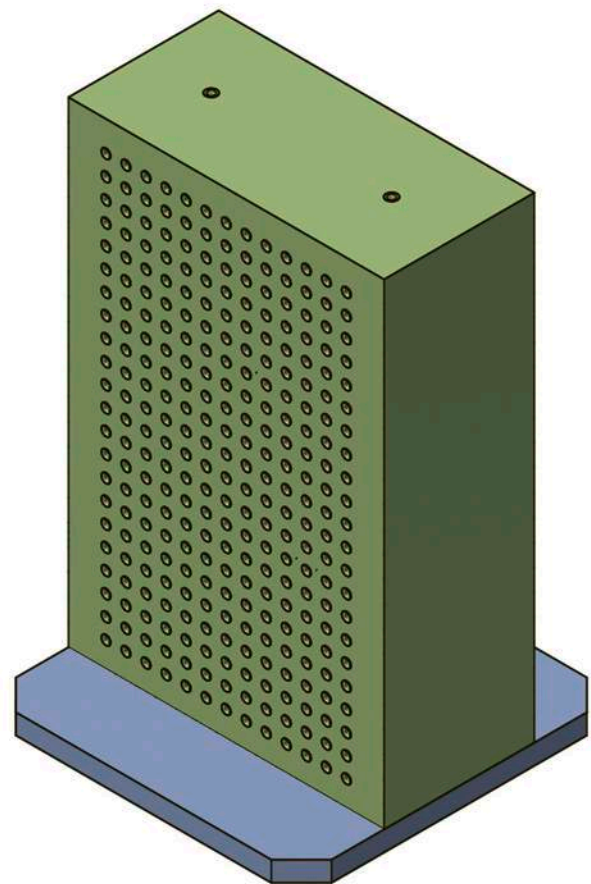
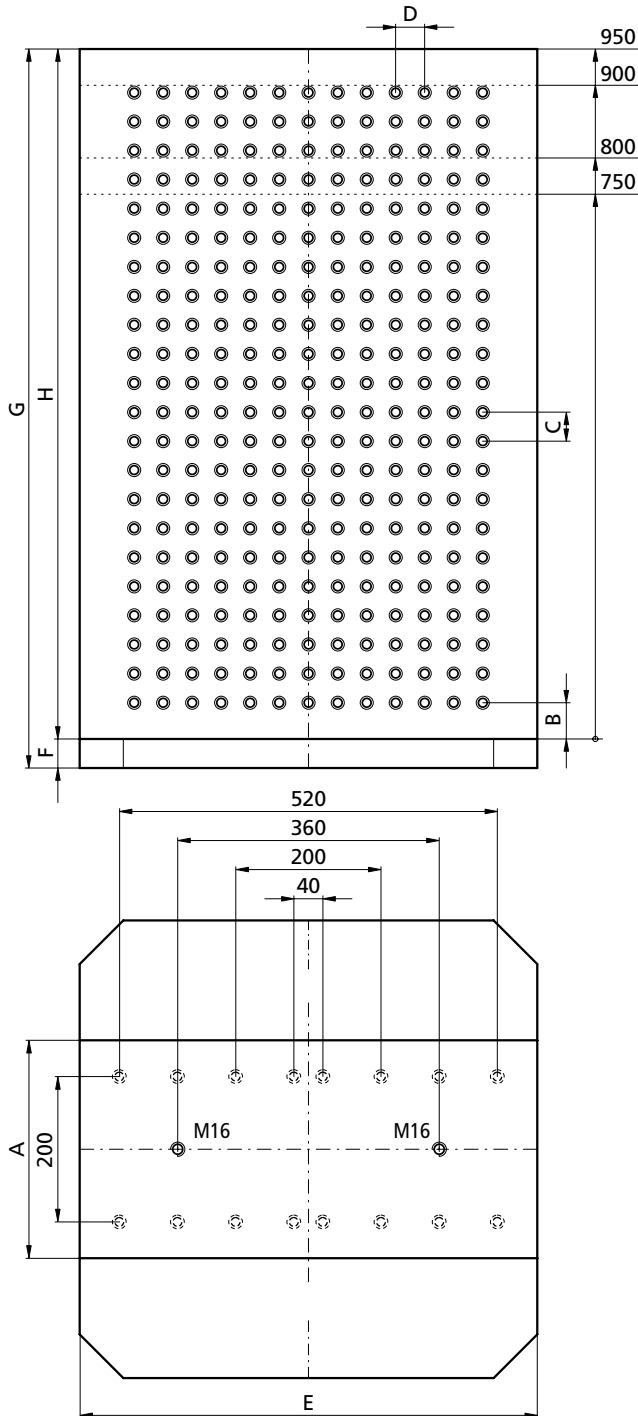

Grundplatte wird passend zu Ihrer Maschinenpalette hergestellt und muss separat bestellt werden!
Base plate according to your machine configuration please order extra!

Mineralgussturm mit
Stahldübel
Epoxy Mineral with
Steel Anchor

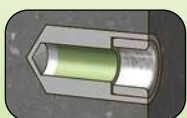

Seite / Page 250

Bestellbeispiel

Ordering example: **MR633075R40** & _____ p. 274

| | kg* | A | B | C | D | E | F | G | H | Raster / Grid |
|--------------------|------|-----|----|----|----|-----|------|-------|------------|----------------|
| MR633075R40 | ~314 | 300 | 50 | 40 | 40 | 630 | (40) | (790) | 750 | 468 x M12/12F7 |
| MR633080R40 | ~333 | 300 | 50 | 40 | 40 | 630 | (40) | (840) | 800 | 494 x M12/12F7 |
| MR633090R40 | ~374 | 300 | 50 | 40 | 40 | 630 | (40) | (940) | 900 | 546 x M12/12F7 |
| MR633095R40 | ~393 | 300 | 50 | 40 | 40 | 630 | (40) | (990) | 950 | 572 x M12/12F7 |

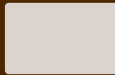

Rechteck
Rectangle

MR7015 ... R50

tripoxyMINERAL

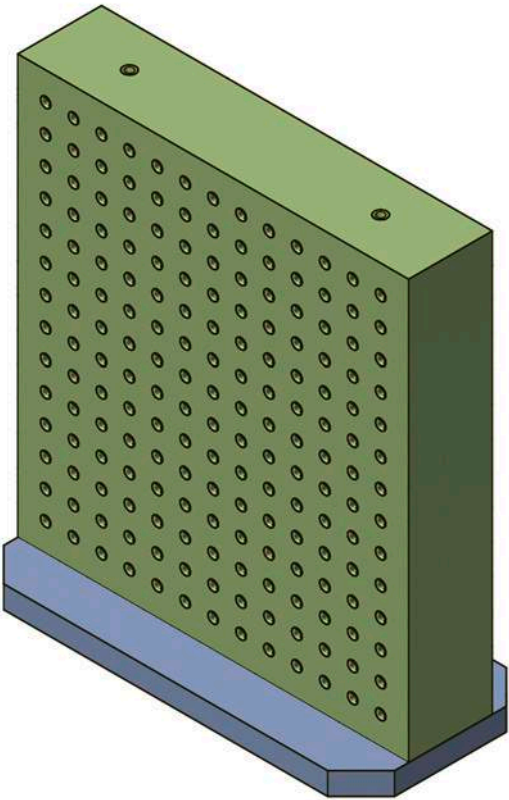
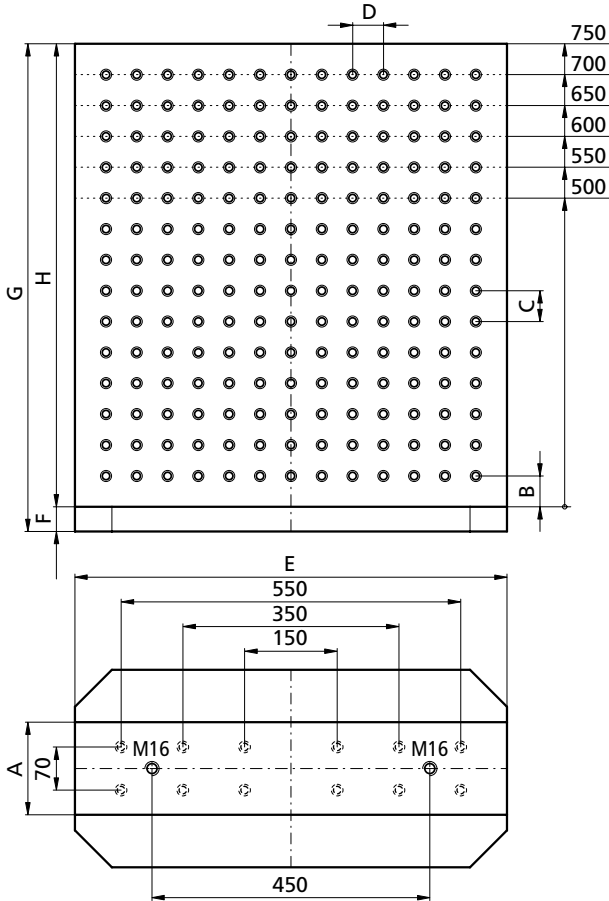

Grundplatte wird passend zu Ihrer Maschinenpalette hergestellt und muss separat bestellt werden!
Base plate according to your machine configuration please order extra!

Mineralgussturm mit Stahldübel
Epoxy Mineral with Steel Anchor

Seite / Page 250

Bestellbeispiel
Ordering example: **MR701550R50** & _____ p. 274

| | kg* | A | B | C | D | E | F | G | H | Raster / Grid |
|--------------------|------|-----|----|----|----|-----|------|-------|------------|----------------|
| MR701550R50 | ~153 | 150 | 50 | 50 | 50 | 700 | (40) | (540) | 500 | 234 x M12/12F7 |
| MR701555R50 | ~168 | 150 | 50 | 50 | 50 | 700 | (40) | (590) | 550 | 260 x M12/12F7 |
| MR701560R50 | ~183 | 150 | 50 | 50 | 50 | 700 | (40) | (640) | 600 | 286 x M12/12F7 |
| MR701565R50 | ~199 | 150 | 50 | 50 | 50 | 700 | (40) | (690) | 650 | 312 x M12/12F7 |
| MR701570R50 | ~214 | 150 | 50 | 50 | 50 | 700 | (40) | (740) | 700 | 338 x M12/12F7 |
| MR701575R50 | ~229 | 150 | 50 | 50 | 50 | 700 | (40) | (790) | 750 | 364 x M12/12F7 |

* Gewicht ohne Grundplatte! / Weight without baseplate!

Separat bestellen / Order separately

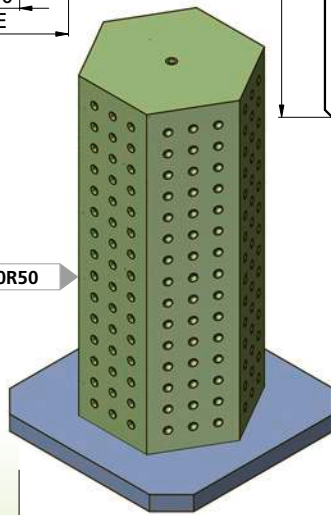
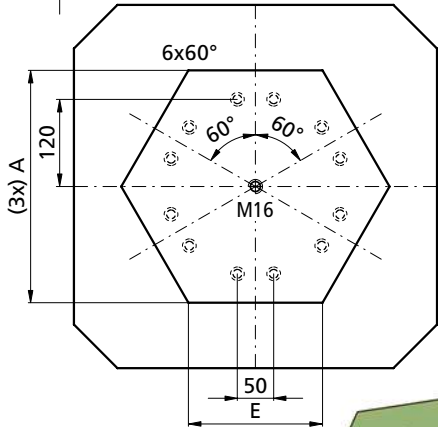
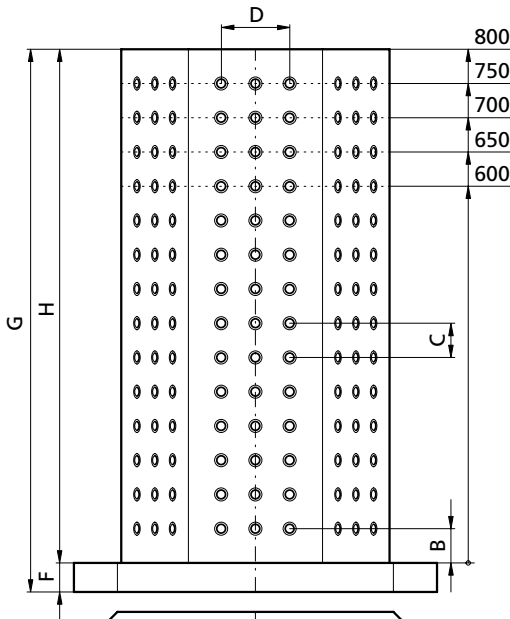

MS321980R50

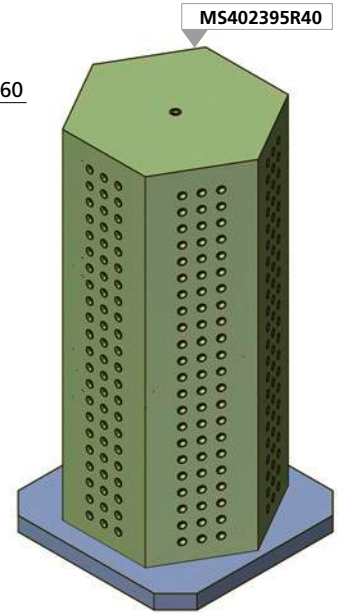
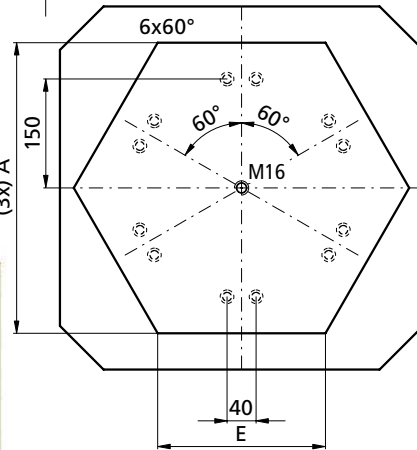
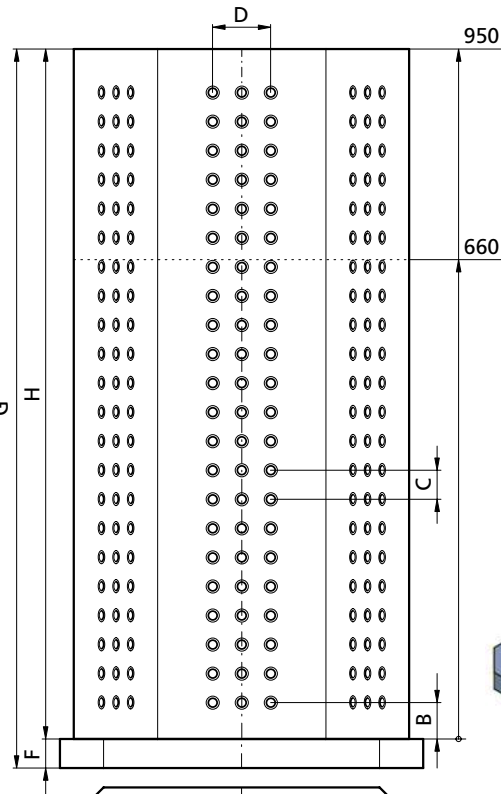

MS402395R40

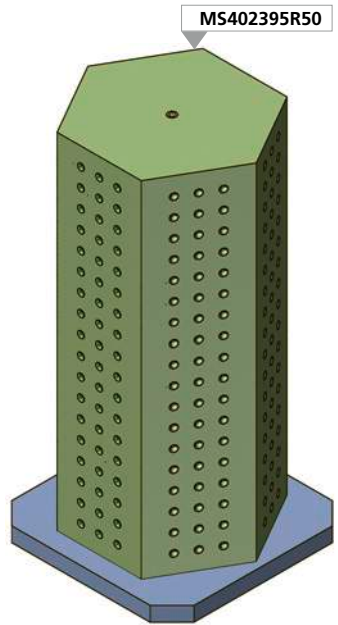

MS402395R50

Mineralgussturm mit
Stahldübel
Epoxy Mineral with
Steel Anchor

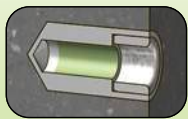

Seite / Page 250

Bestellbeispiel

Ordering example: MS321966R80 &

p. 274

Grundplatte wird passend
zu Ihrer Maschinenpalette
hergestellt und muss separat
bestellt werden!

Base plate according to your
machine configuration please
order extra!

| | kg* | A | B | C | D | E | F | G | H | Raster / Grid |
|-------------|------|-----|----|----|-----|-----|------|-------|-----|----------------|
| MS321960R50 | ~120 | 320 | 50 | 50 | 100 | 184 | (40) | (640) | 600 | 198 x M12/12F7 |
| MS321965R50 | ~131 | 320 | 50 | 50 | 100 | 184 | (40) | (690) | 650 | 216 x M12/12F7 |
| MS321970R50 | ~142 | 320 | 50 | 50 | 100 | 184 | (40) | (740) | 700 | 234 x M12/12F7 |
| MS321975R50 | ~154 | 320 | 50 | 50 | 100 | 184 | (40) | (790) | 750 | 252 x M12/12F7 |
| MS321980R50 | ~165 | 320 | 50 | 50 | 100 | 184 | (40) | (840) | 800 | 270 x M12/12F7 |
| MS402366R40 | ~167 | 400 | 50 | 40 | 80 | 231 | (40) | (700) | 660 | 270 x M12/12F7 |
| MS402395R40 | ~311 | 400 | 50 | 40 | 80 | 231 | (40) | (990) | 950 | 396 x M12/12F7 |
| MS402366R50 | ~160 | 400 | 50 | 50 | 100 | 231 | (40) | (700) | 660 | 216 x M12/12F7 |
| MS402395R50 | ~260 | 400 | 50 | 50 | 100 | 231 | (40) | (990) | 950 | 324 x M12/12F7 |

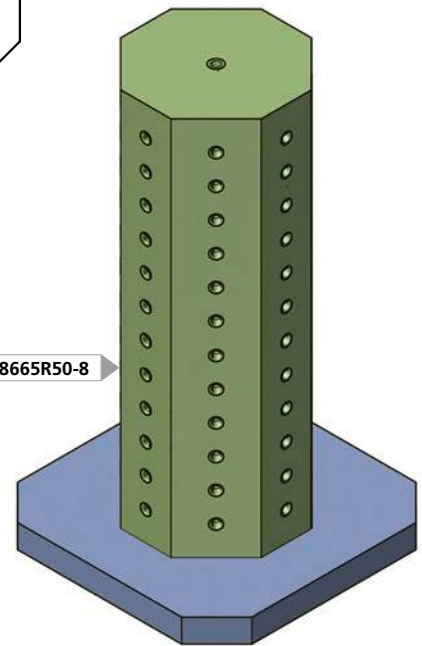
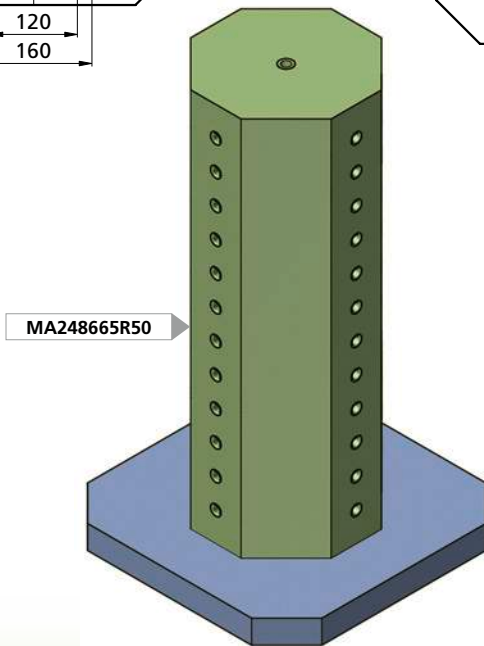
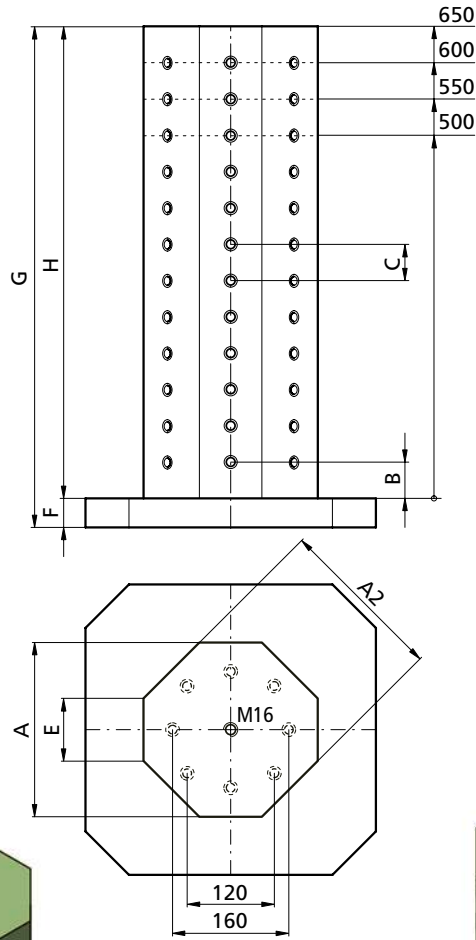
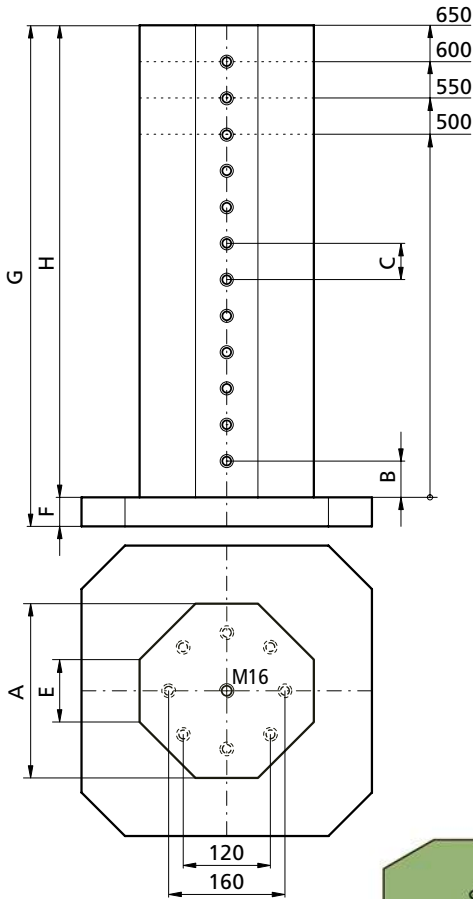

Mineralgussturm mit
Stahldübel
Epoxy Mineral with
Steel Anchor

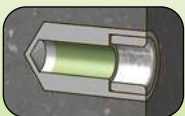

Seite / Page 250

Bestellbeispiel
Ordering example: **MR24865R50** &

p. 274

Grundplatte wird passend
zu Ihrer Maschinenpalette
hergestellt und muss separat
bestellt werden!
Base plate according to your
machine configuration please
order extra!

| | kg* | | | A | A2 | B | C | | E | F | G | H | Raster / Grid |
|--------------|-----|--|--|-----|-----|----|----|--|----|------|-------|------------|---------------|
| MA24865R50 | ~56 | | | 240 | | 50 | 50 | | 86 | (40) | (540) | 500 | 36 x M12/12F7 |
| MA24865R50 | ~61 | | | 240 | | 50 | 50 | | 86 | (40) | (590) | 550 | 40 x M12/12F7 |
| MA24866R50 | ~70 | | | 240 | | 50 | 50 | | 86 | (40) | (640) | 600 | 44 x M12/12F7 |
| MA24866R50 | ~72 | | | 240 | | 50 | 50 | | 86 | (40) | (690) | 650 | 48 x M12/12F7 |
| MA24865R50-8 | ~61 | | | 240 | 230 | 50 | 50 | | 86 | (40) | (540) | 500 | 72 x M12/12F7 |
| MA24865R50-8 | ~67 | | | 240 | 230 | 50 | 50 | | 86 | (40) | (590) | 550 | 80 x M12/12F7 |
| MA24866R50-8 | ~71 | | | 240 | 230 | 50 | 50 | | 86 | (40) | (640) | 600 | 88 x M12/12F7 |
| MA24866R50-8 | ~79 | | | 240 | 230 | 50 | 50 | | 86 | (40) | (690) | 650 | 96 x M12/12F7 |

* Gewicht ohne Grundplatte! / Weight without baseplate!

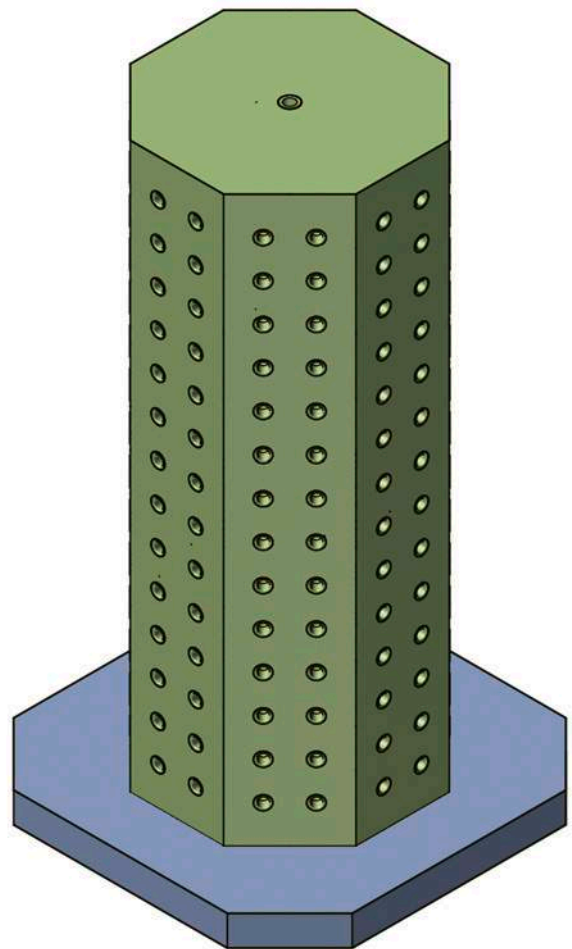
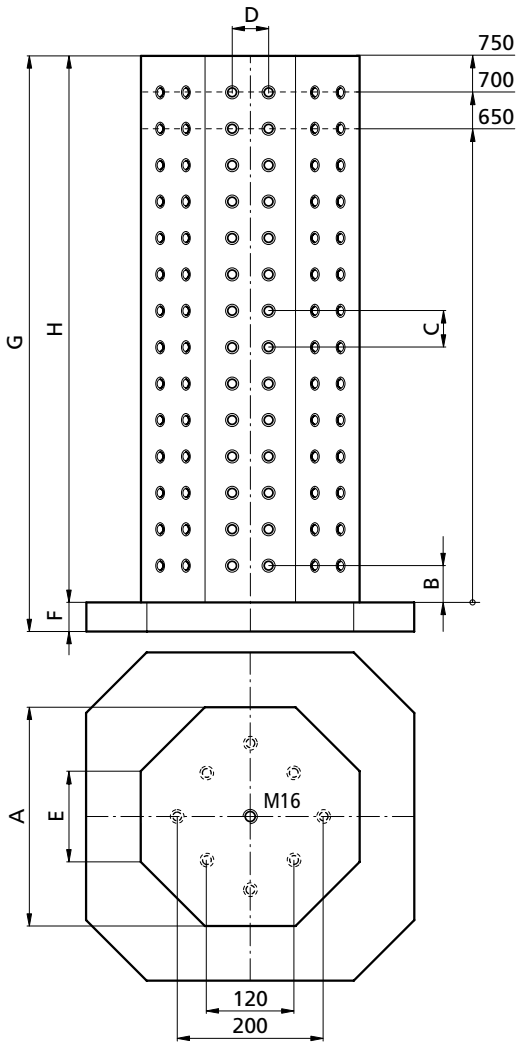

Grundplatte wird passend zu Ihrer Maschinenpalette hergestellt und muss separat bestellt werden!
Base plate according to your machine configuration please order extra!

Mineralgussturm mit
Stahldübel
Epoxy Mineral with
Steel Anchor

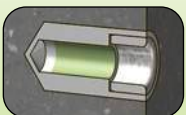

andere Höhen auf Anfrage
other heights on request

Seite / Page 250

Bestellbeispiel

Ordering example: MA301265R50-8-2 & p. 274

| | kg* | A | B | C | D | E | F | G | H | Raster / Grid |
|-----------------|------|-----|----|----|----|-----|------|-------|-----|----------------|
| MA301265R50-8-2 | ~118 | 300 | 50 | 50 | 50 | 125 | (40) | (690) | 650 | 192 x M12/12F7 |
| MA301270R50-8-2 | ~130 | 300 | 50 | 50 | 50 | 125 | (40) | (740) | 700 | 208 x M12/12F7 |
| MA301275R50-8-2 | ~156 | 300 | 50 | 50 | 50 | 125 | (40) | (790) | 750 | 224 x M12/12F7 |

* Gewicht ohne Grundplatte! / Weight without baseplate!

Mineralgusserhöhung für 5-Achsenmaschinen

Epoxy casting raises blocks for 5-axis machines

tripoxyMINERAL

| Art. Nr. | kg | H | Raster / Grid R50 |
|---------------------|-------|-----|----------------------|
| MUB2817-H85 | ~8,7 | 85 | 9 x M12/12F7 |
| MUB2817-H100 | ~10,3 | 100 | |
| MUB2817-H125 | ~12,9 | 125 | |

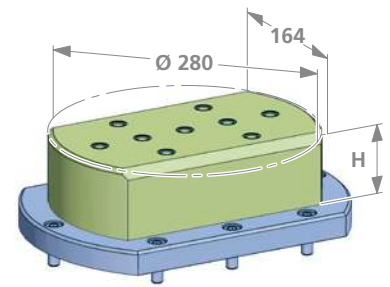

Mineralgusserhöhungen um eine optimale Bearbeitungshöhe und Zugänglichkeit mit der Spindel zu erreichen.

Epoxy casting raises to achieve an optimal machining height and accessibility with the spindle.

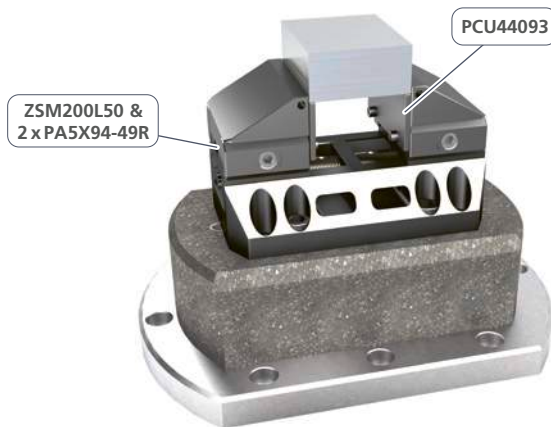

| Art. Nr. | kg | Raster / Grid R50 |
|--------------------|-------|----------------------|
| MUB3535H140 | ~44,1 | 73 x M12/12F7 |

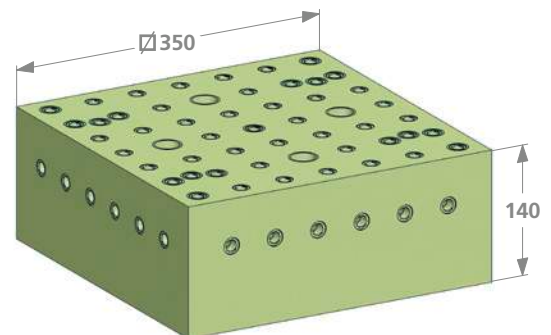

Diese Mineralgusserhöhung mit schrägen Basisschienen (PCB50207W27) und einer seitlichen Anordnung weiterer Spannstellen, bietet Ihnen eine Vielzahl an Spannmöglichkeiten.

This mineral casting raises with inclined base rails (PCB50207W27) and a lateral arrangement of further clamping points offers you a wide range of clamping possibilities.

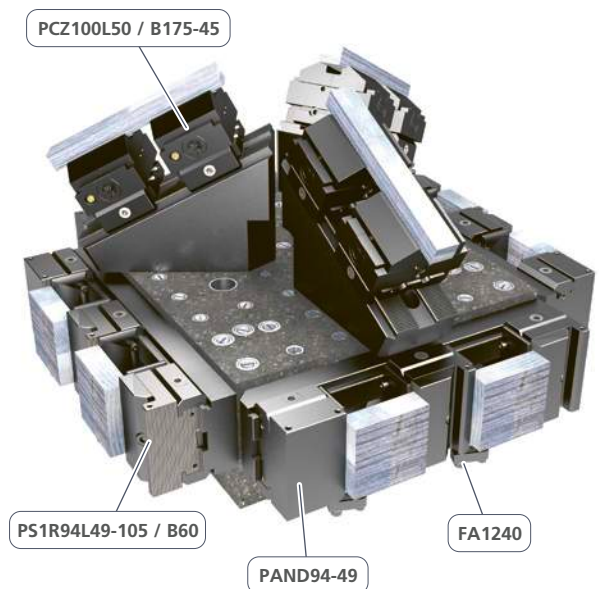
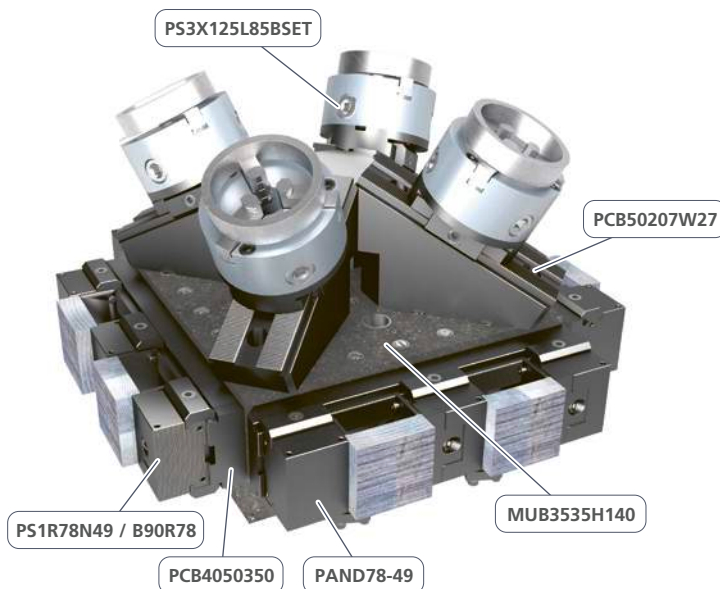

SMK24-24-42 OPP200

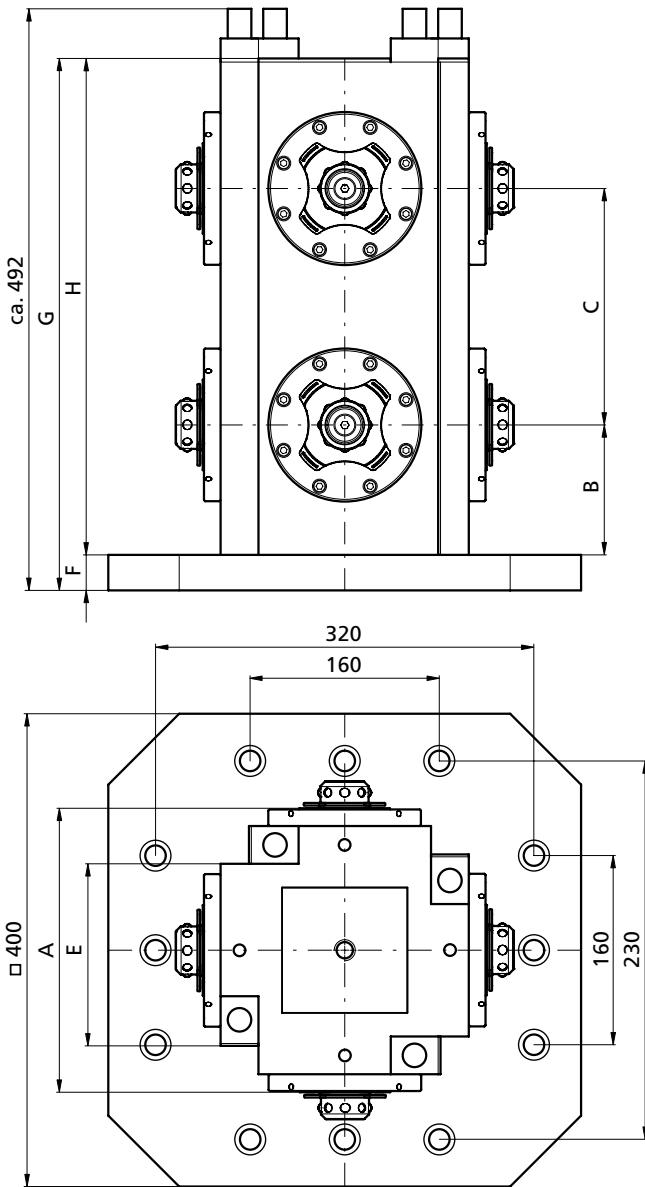

SMK30-17-42 OPP200

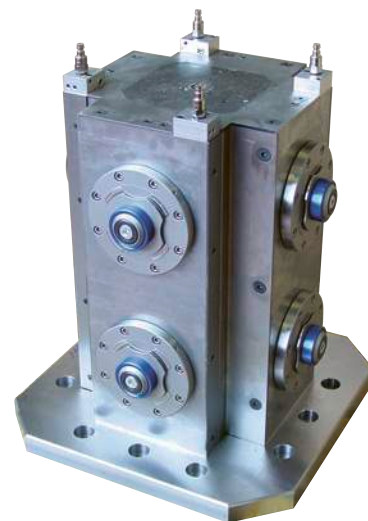
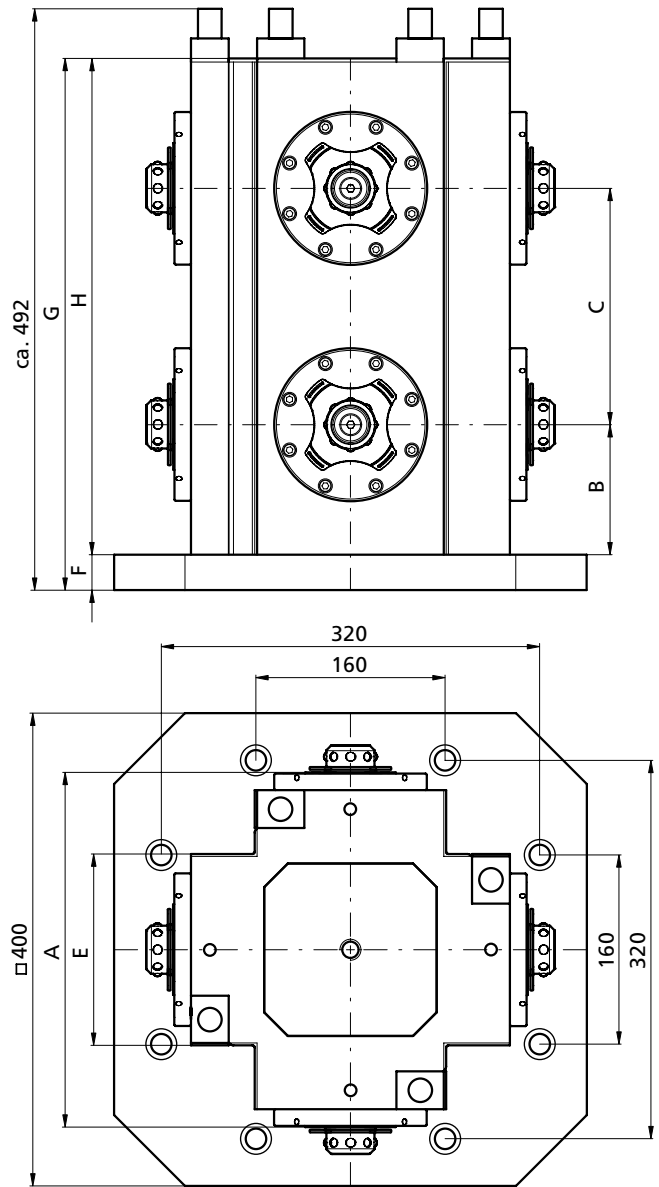

Stahl-Mineralguss

Steel-epoxy mineral tombstones

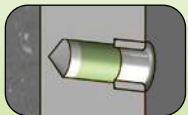

andere Höhen auf Anfrage
other heights on request

Seite / Page 250

Bestellbeispiel
Ordering example: **SMK242442OPP-200**

| | kg | A | B | C | E | F | G | H | Raster / Grid |
|-------------------|------|-----|-----|-----|-----|------|-------|-----|---------------|
| SMK24-24-42OPP200 | ~120 | 240 | 110 | 200 | 166 | (30) | (450) | 420 | OPP-200 |
| SMK30-17-42OPP200 | ~142 | 300 | 110 | 200 | 166 | (30) | (450) | 420 | OPP-200 |

Stahl-Mineralgusstürme
Steel-epoxy mineral tombstones

tripoxyMINERAL

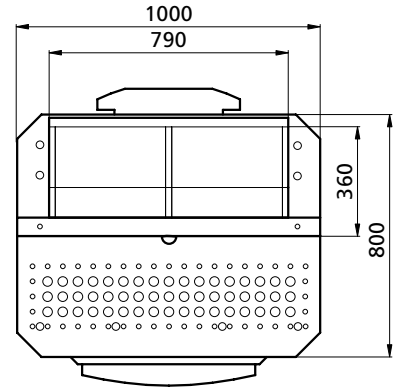
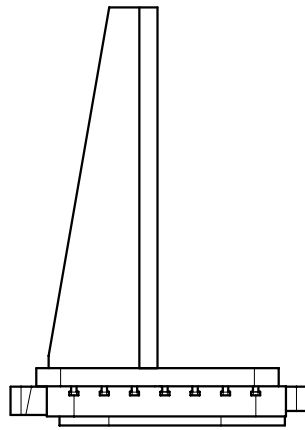
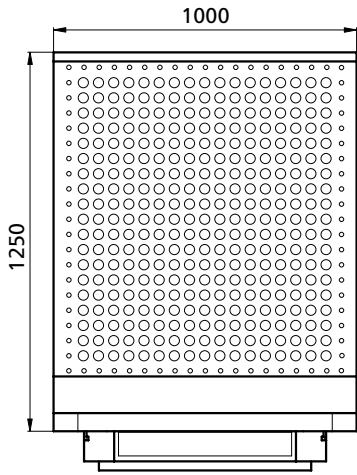

Gesamtgewicht
 Total weight **~1300kg**



Epoxy

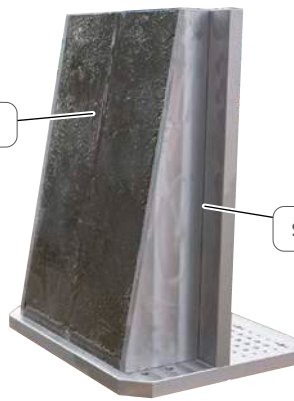

Stahl / Steel



SPECIALS

Patent pending



Beine aus rostfreiem Stahl oder Holz
 Legs made of stainless steel or wood

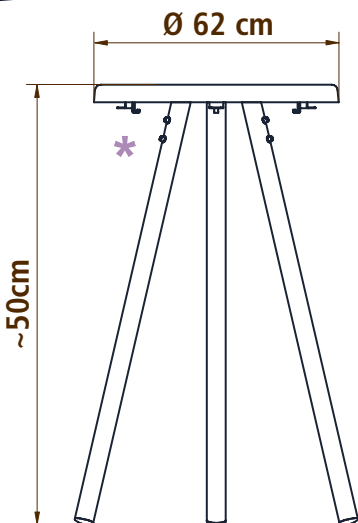

* Inkl. 3x Flaschenöffner / Kleiderhaken
 Incl. 3x bottle opener / coat hook



Ihr Logo hier
 Your logo here



Salontisch
Salon table

Jeder Tisch ist ein Unikat
 - Hergestellt aus Schweizer Stein-Granulat

Each table is unique
 - Made from Swiss stone granulate

Art. Nr.

MST-TRI-600

Grundplatten für Mineralgusstürme
Base plate for epoxy mineral tombstone

| | A | B | C | kg |
|-------------|-----|-----|----|------|
| GPL30040 | 300 | 300 | 40 | ~27 |
| GPL40040 | 400 | 400 | 40 | ~47 |
| GPL50040 | 500 | 500 | 40 | ~74 |
| GPL45040 | 450 | 450 | 40 | ~61 |
| GPL50040040 | 500 | 400 | 40 | ~58 |
| GPL63040 | 630 | 630 | 40 | ~120 |
| GPL80040 | 800 | 800 | 40 | ~195 |

Rasterplatten für 5AX-Master
Grid plate for 5AX-Master

| | A | B | C | Raster / Grid | kg |
|--------------|-------|-----|----|---------------|-----|
| RPQ50504-R50 | 500 | 500 | 40 | M12/12F7 | ~74 |
| RPD504-R50 | ∅ 500 | | 40 | M12/12F7 | ~64 |

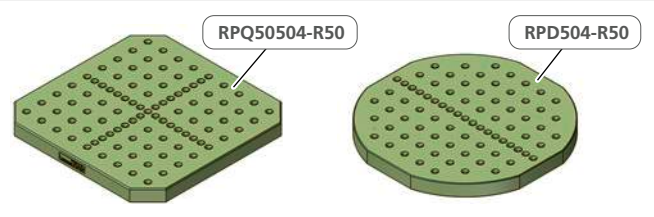

Andere Grössen auf Anfrage
Other dimensions available on request

Im Lieferumfang: Schrauben zur Befestigung des Turms, ohne Positionierzapfen und Schrauben maschinenseitig.
The package: Screws for fixing the tombstone, without screws and counter piece to the machine side.

Bohrungen der Grundplatte / Drill holes in the baseplate:
Kundenspezifisch an die Maschine angepasst
Made up to customer's specifications

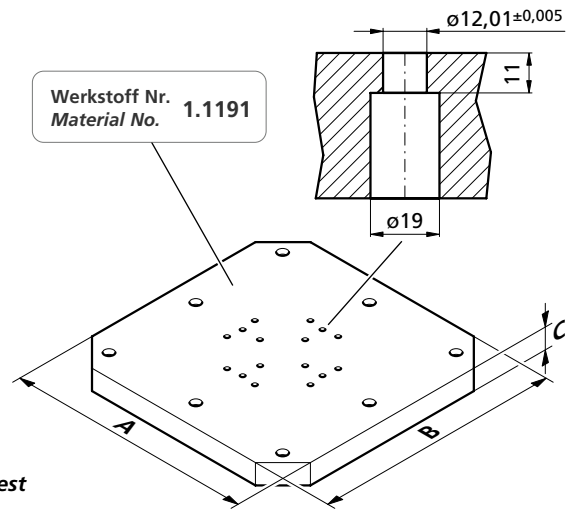

GPL40040-UV

kg ~40,34

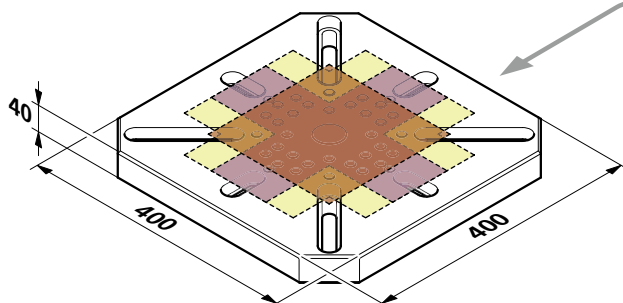
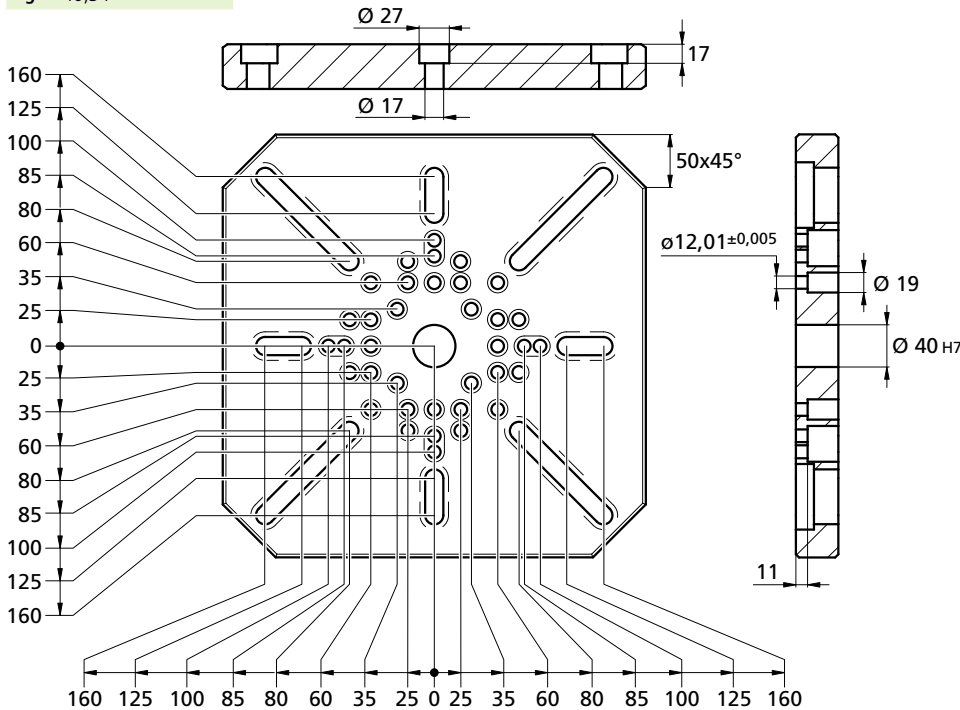

27 verschiedene Mineralgusstürme passend zu dieser Grundplatte.
27 different Epoxy mineral tombstone are suitable for this base plate.

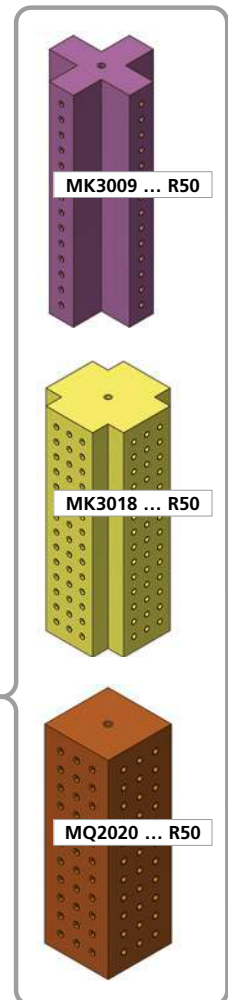

MABD501550

MABD502050

MABD502550 MABD503050

tripoxyMINERAL

Abdeckbleche zum Schutz der Oberfläche der Mineralgusstürme
Cover plates for surface protection of epoxy mineral tombstones

MABD501550

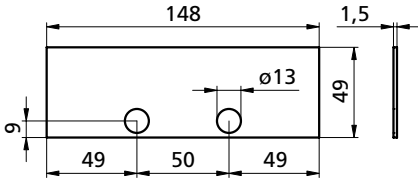

MABD502050

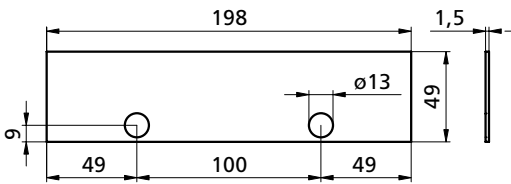

MABD502550

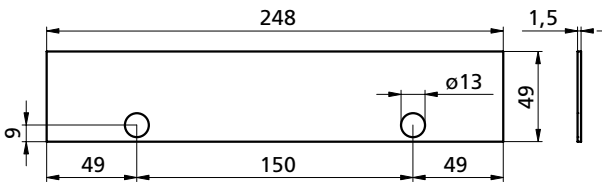

MABD503050

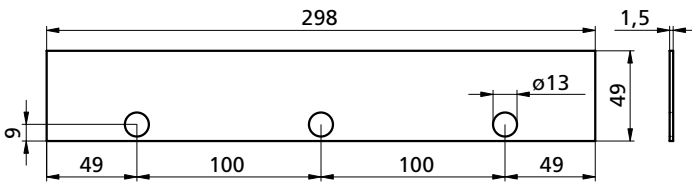

M12X25DIN7984

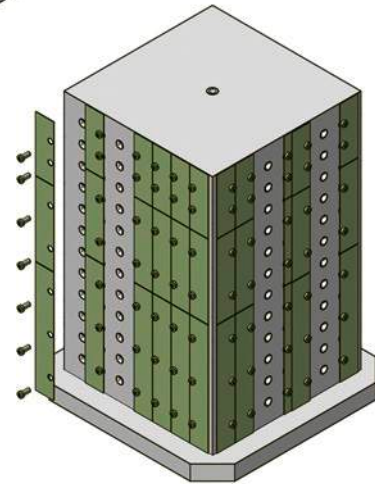
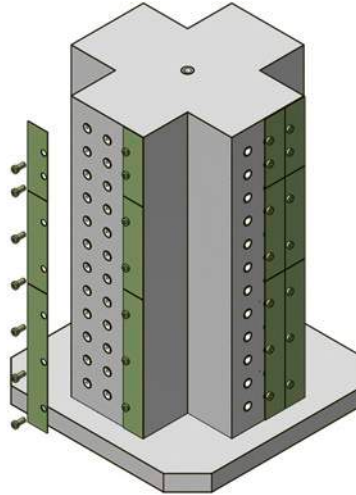
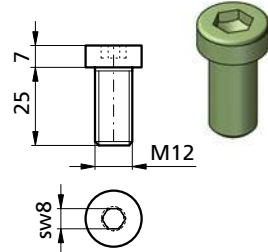

Stahl-Mineralguss
Steel-epoxy mineral tombstones

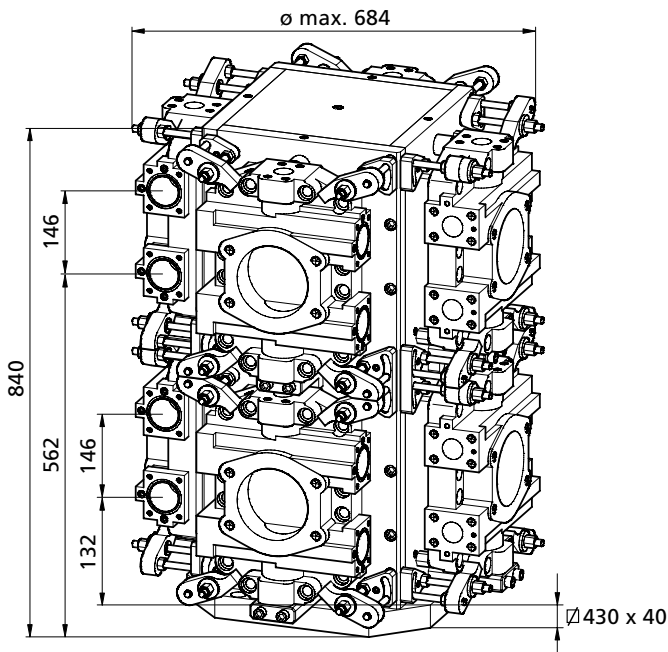

Gesamtgewicht
Total weight
~600kg

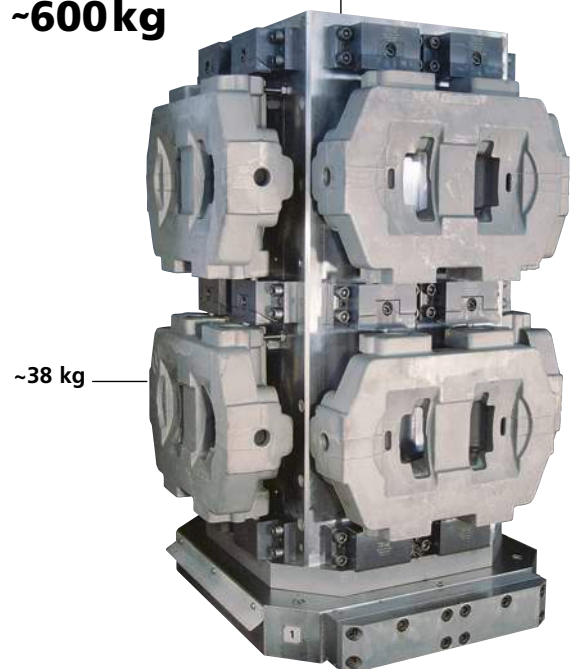

Stahl Mineralgusserhöhungen

Steel-epoxy raises blocks

SMUB2373H220

SMUB3373H220

tripoxyMINERAL

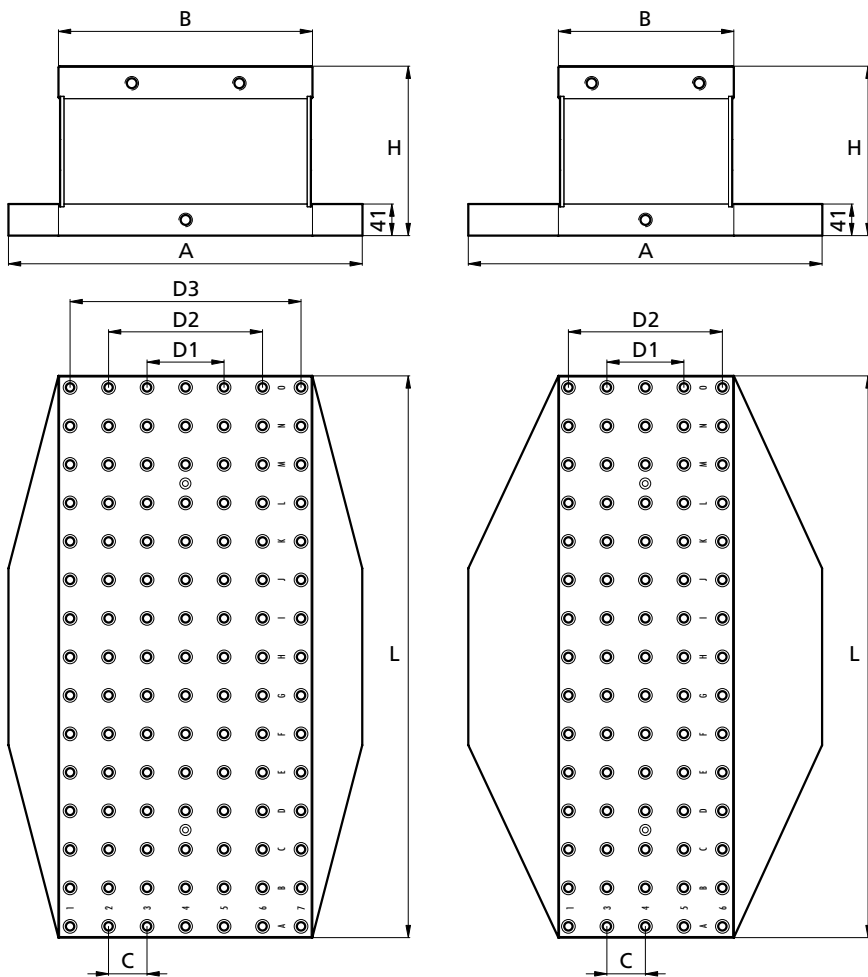

**Entwickelt für die Luftfahrt.
Gewappnet für höchste Anforderungen.**

Sehr hohe Vibrationsdämpfung dank Kern aus Mineralguss. Hohe Festigkeit dank Ummantelung aus Stahl. Begünstigt die Gewichtsreduktion wodurch die Maschine geschont wird.

Mit integrierten Vakuum Kanälen erhältlich.

**Developed for aviation.
Prepared for the highest requirements**

Very high vibration damping thanks to mineral cast core. High strength thanks to the coat made of steel. Supports weight reduction which protects the machine.

Raisers can be made with integrated vacuum channels.

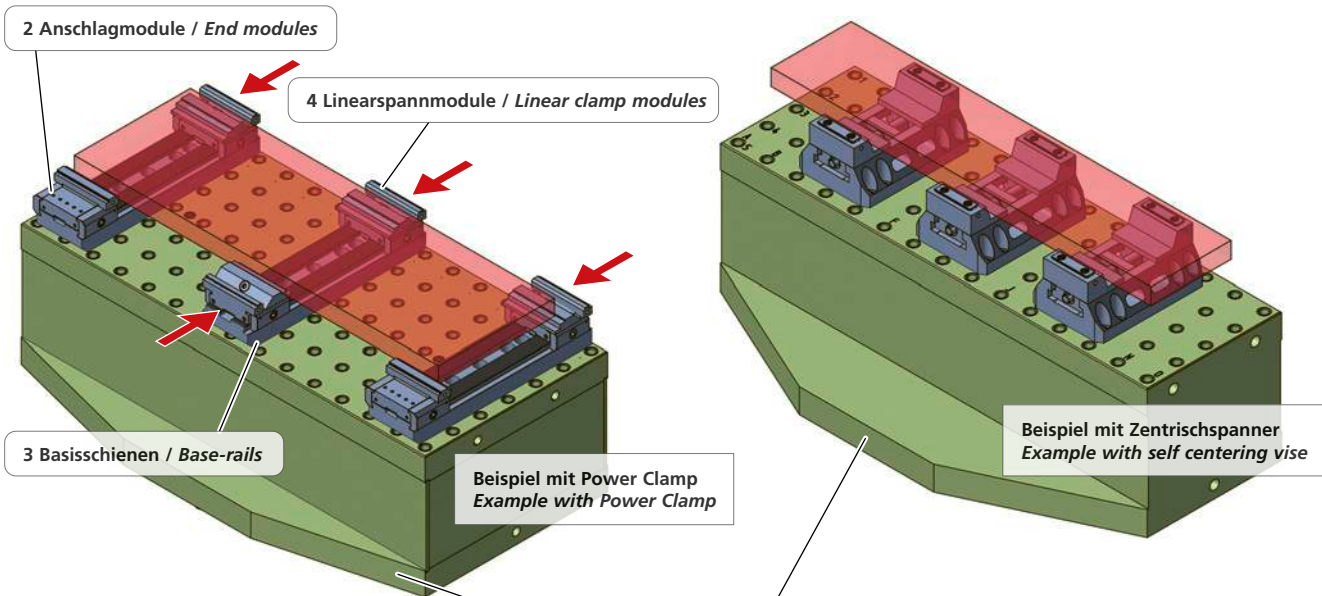

Grundplatte wird passend zu Ihrer Maschinenpalette hergestellt!
Base plate according to your machine configuration!

Stahl-Mineralguss
Steel-epoxy mineral tombstones

kg

Bestellbeispiel
Ordering example: **SMUB2373H220**

| | | A | B | C | D1 | D2 | D3 | H | L | Raster / Grid |
|--------------|--------|-----|-----|----|-----|-----|-----|-----|-----|----------------|
| SMUB2373H220 | ~168,0 | 460 | 230 | 50 | 100 | 200 | | 220 | 730 | 75 x M12/12F7 |
| SMUB3373H220 | ~214,4 | 460 | 330 | 50 | 100 | 200 | 300 | 220 | 730 | 105 x M12/12F7 |

Separat bestellen / Order separately

Stahl Mineralgusserhöhungen mit integriertem Vakuum Anschluss

Steel-epoxy raises block with integrated vacuum

tripoxyMINERAL

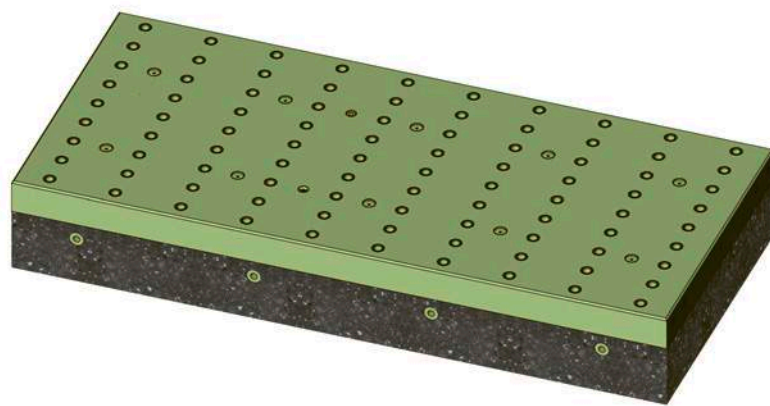
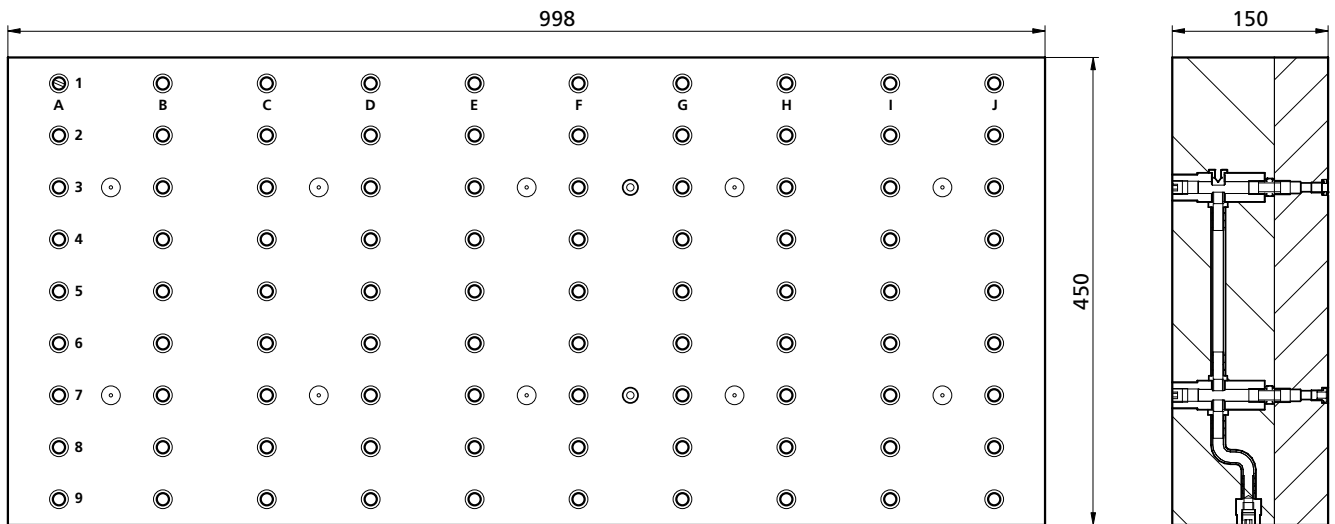

Balken und Würfel aus Stahl-Mineralguss
Trunion and cubes made from steel epoxy

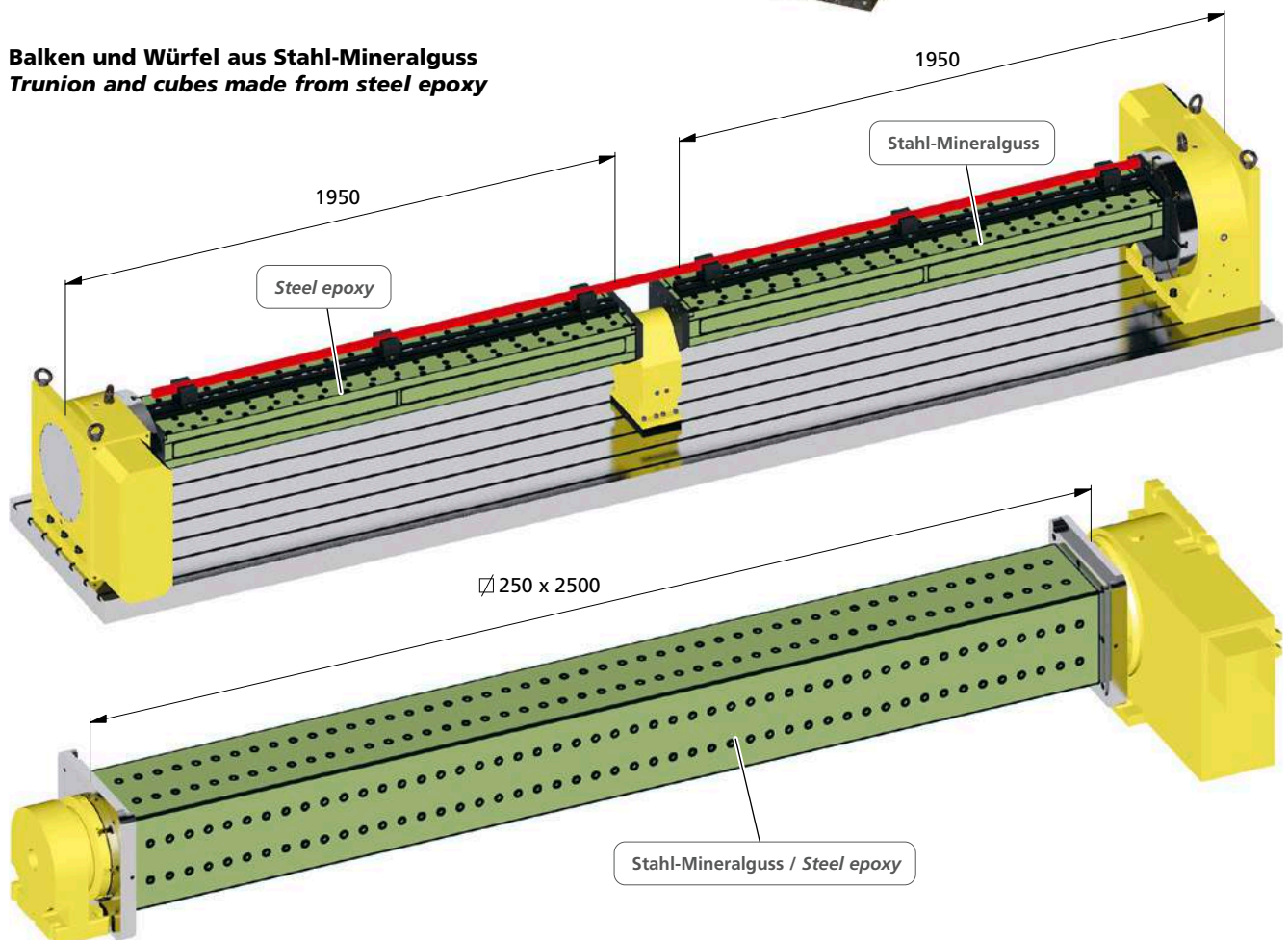

Mineralgusstürme seit
Epoxy tombstones since

1998

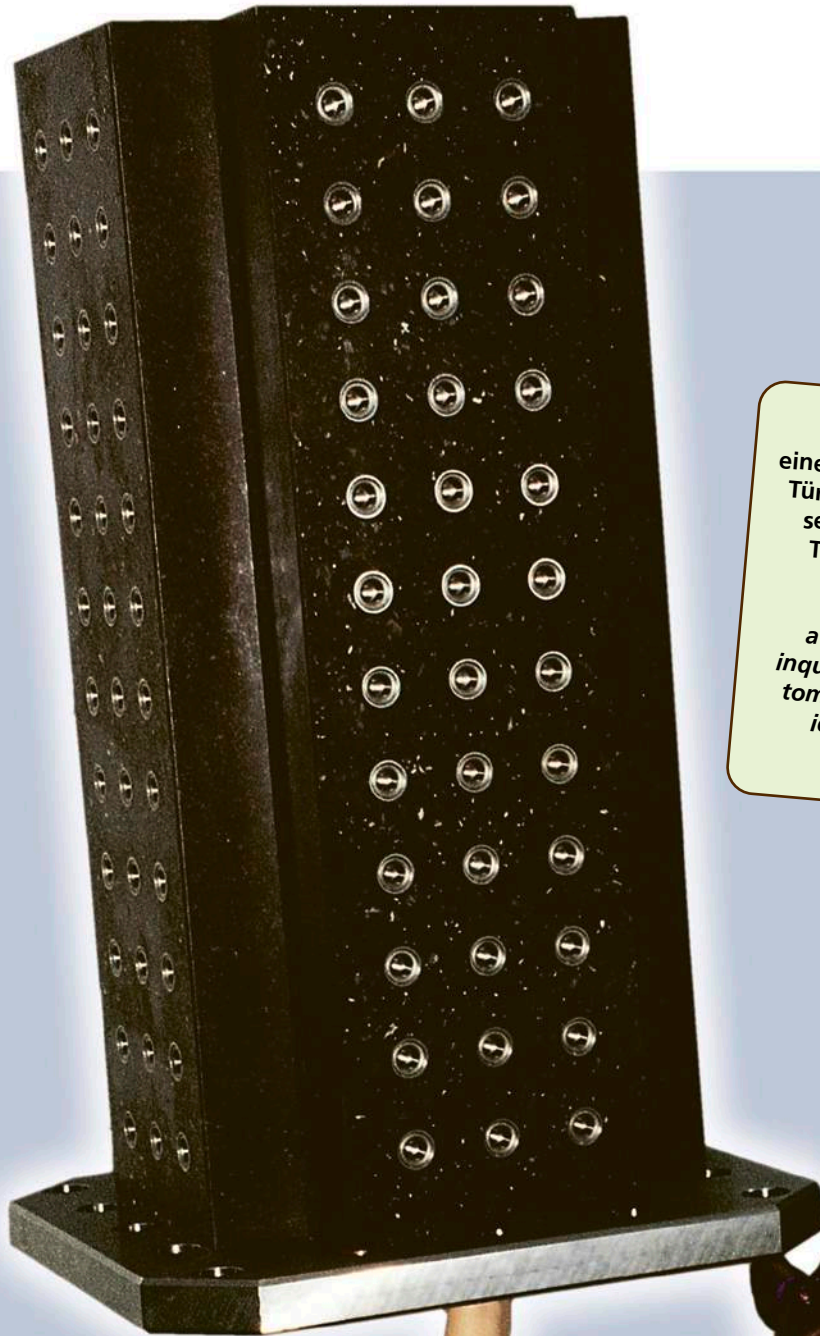



Beat Baumgartner erhält von einem Kunden eine Anfrage für leichte Türme, die aber nicht aus Aluminium sein dürfen. Er hat die Idee, einen Turm aus Mineralguss zu bauen.

Beat Baumgartner receives a request from a customer who inquires about light, non-aluminium tombstones. He comes up with the idea to build a mineral epoxy tombstone.

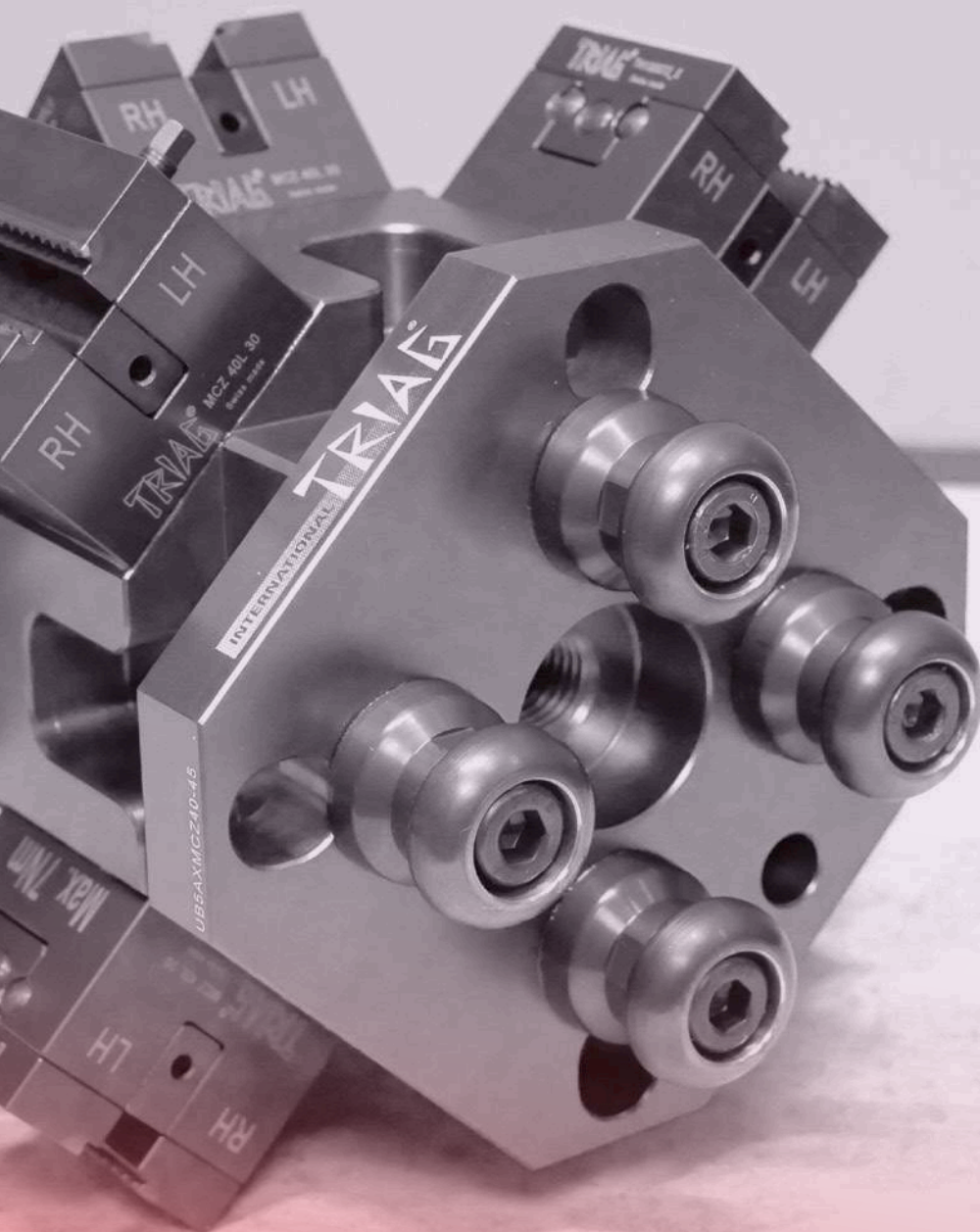

*opp*SYSTEM & 5axes



| | | |
|---|---|-----------|
|  | Einleitung <i>Introduction</i> | 281 - 283 |
| | Anwendungsbeispiele <i>Examples of application</i> | 284 - 285 |
| | Mechanisches Nullpunktsystem mit diversen Spannlösungen <i>Mechanical zero point system with different workholding solutions</i> | 286 |
| | 0-Punkt Schnellwechselsystem <i>Mechanical zero point system</i> | 287 |
| | 4-Achs Lösungen für mechanische 0-Punkt Schnellwechselsysteme <i>4-axis solution for mechanical 0-point quick change systems</i> | 288 |
| | 0-Punkt Erhöhung & Ausrichtplatte <i>Zero point riser & Alignment plate</i> | 289 |
| | Dreibackenfutter <i>Three-jaw chuck</i> | 290 |
| | Klemmbüchse <i>Clamping-case</i> | 291 |
| | Zentriereinheit <i>Chuck unit</i> | 292 |
| | Palettenträger <i>Receiver chuck with chucks</i> | 293 |
| | MTS Palettier-System <i>MTS palleting system</i> | 297 - 300 |
| | Zubehör <i>Accessoires</i> | 301 |

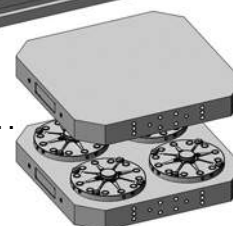
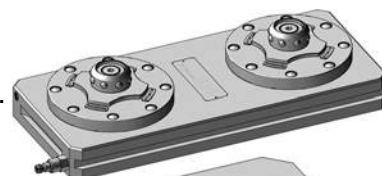
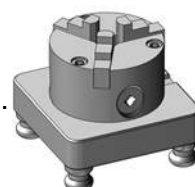
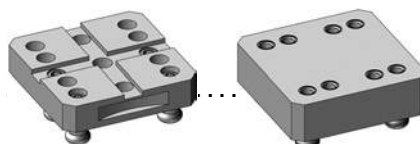

Nullpunkt-Palettiersystem

Zero-point palleting system

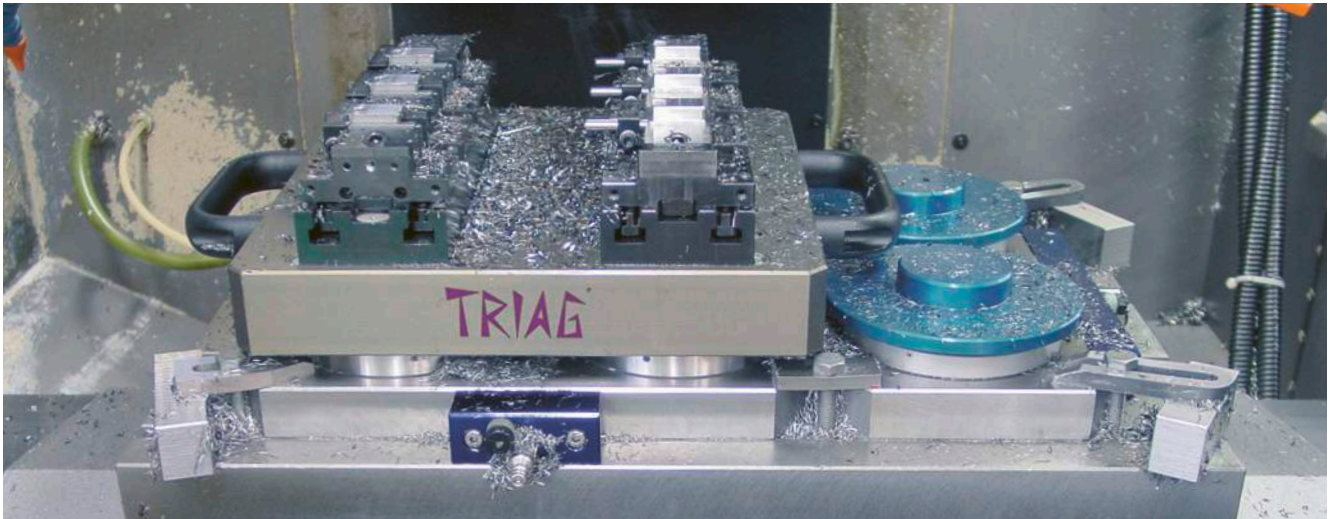

In den letzten Jahren wurden die Werkzeugmaschinen viel leistungsfähiger. Damit wurden die Bearbeitungszeiten wesentlich kürzer. Aufgrund der vom Auftraggeber verlangten Lieferzeiten „just in time“ sind aber die Losgrößen geringer geworden, was zu vermehrten Einrichtzeiten führt.

The productivity of modern machining centers has been drastically increased over the past years. Hence the time per workpiece is falling. On the contrary the batch sizes are getting smaller due to the increasing trend to „just in time“ production.

Auch die technisch hochentwickelten Maschinen sind jedoch immer noch mit einem T- Nuten Tisch ausgerüstet. Die Befestigung und das Ausrichten des zu bearbeitenden Werkstückes auf dem T-Nutentisch kann nur während der (teuren) Maschinen-Stillstandszeit erledigt werden. Diese Unproduktivität kumuliert sich, wenn die Werkstückbearbeitung mehrere Maschinenprozesse und somit mehrmaliges Befestigen und Ausrichten erfordert.

This means that the machine must be set up more frequently. Is the machine not equipped with a pallet changer, the set up and the changing of workpieces may only be accomplished during the stand still of the machine. This idling of the machine results in the loss of costly productive machine time. As it is, the aim of any machining facility to keep the spindle turning, the unproductive time must be minimized. As any machinist knows, the set up and alignment of workpieces on a T-slot table is very awkward and time consuming.

Die Lösung, die wir Ihnen für dieses Problem bieten, ist unser neuartiges, modulares Palettiersystem, das oppSystem.

The TRIAG opp (Zero-Point-Palleting) System represents an ideal interface between machining table and workholding device.

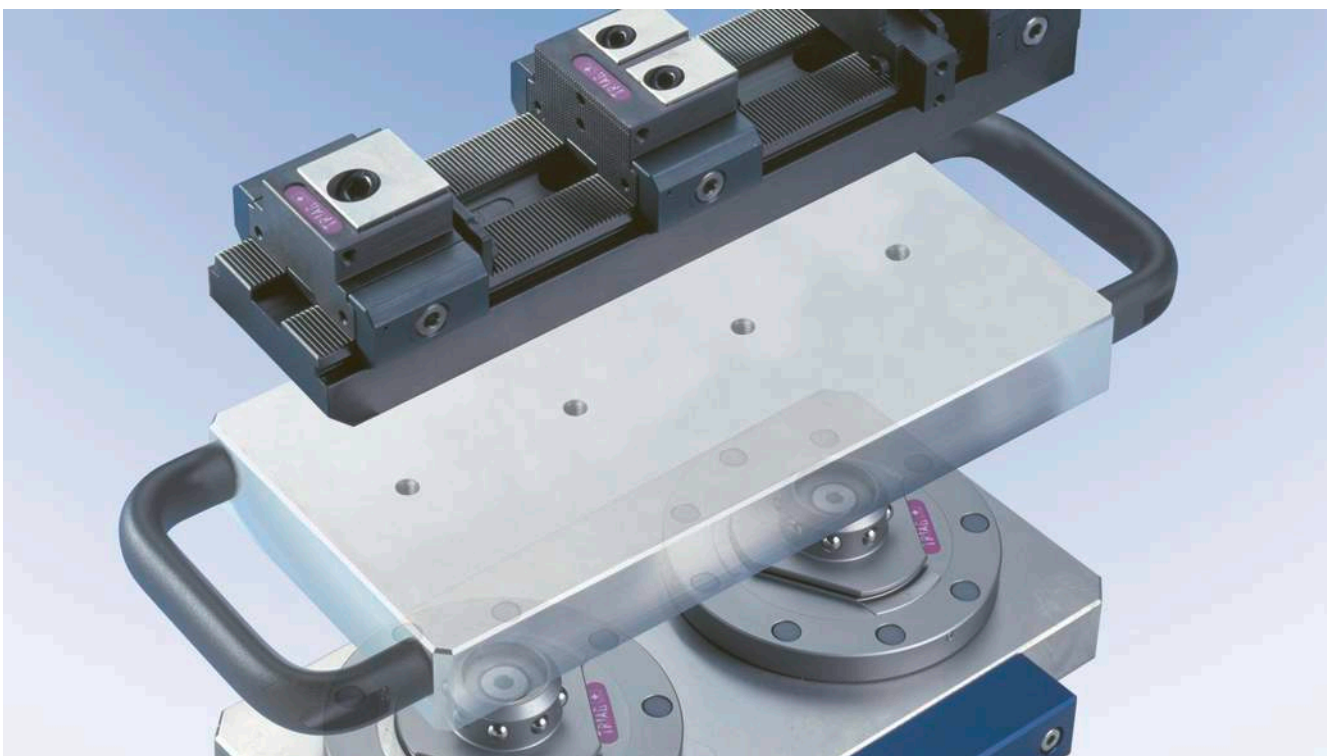

Das System besteht aus dem auf dem Maschinentisch der Werkzeugmaschine montierten Palettenträger und mindestens zwei Paletten oder mit Zentrier- und Klemmbüchsen ausgerüsteten Werkstückträgern. Die sehr präzise gefertigte Schnittstelle zwischen dem Palettenträger und der Palette ermöglicht ein sekundenschnelles Ein- und Auswechseln der Paletten, auf welcher ausserhalb der Werkzeugmaschine das zu bearbeitende Werkstück montiert und positioniert wird. Es wird eine sehr hohe Ausnutzung der theoretisch zur Verfügung stehenden Maschinenlaufzeit erreicht. Dies erhöht die Produktivität der Maschine und damit die Wirtschaftlichkeit des ganzen Betriebes.

Im Gegensatz zu vielen anderen Palettiersystemen auf dem Markt ist die Dimension des oppSystems in Form von Stichmassen genormt und richtet sich damit nach den individuellen Werkstückdimensionen. Die patentierte Konstruktion erlaubt überdies auch die unbemannte Be- und Entladung mit Hilfe eines Beschickungsgerätes.

Mit dem oppSystem sind 750'000 Spannungen ohne Referenzverlust möglich, bei einer Repetiergenauigkeit von $\pm 0,002$ mm. Das Lösen erfolgt pneumatisch mit ca. 6 bar, womit keine Mehrkosten für Hydraulikaggregate entstehen. Eine allfällig entstehende Wärmeausdehnung wird über die federnde Zentrierung kompensiert. Alle wichtigen Bauteile sind wartungsarm, leicht zu überprüfen und im Bedarfsfall einfach auszutauschen.

On the machine table the receiver chuck is installed. This chuck may consist of one, two, four, six or more receiver units. Onto these air operated receiver chucks a pallet, a fixture or a vice is mounted within a matter of seconds. On the bottom surface of the workholding devices centering rings are inserted. These centering rings are ground to a very high accuracy permitting the locking down of the workholding device with a repeatability of ± 0.002 mm on all three axes. The chucks are locked by spring force and unlocked by compressed air of 6 bar. This means that no hose connection is necessary during machining. Hydraulic pumps or hydraulic amplifiers are superfluous.

The patented oppSystem allows for 750'000 locking and unlocking cycles without loss of positioning accuracy. If necessary, the changing of the pallet may be accomplished by a robot or a handling system. Thermal expansion is compensated for by the spring loaded centering units.

Due to the unique oppSystem it is possible to bring the loading and unloading of the actual workpiece out of the machine which guarantees a maximum of productive machine time. Maintenance is simple as all components are easily accessible and replaceable. There are standard receiver chucks and pallets available with two or four receiver units. For other solutions or dedicated fixture you should contact TRIAG or your nearest dealer.

SMK30-17-42 OPP200 ~ 142 kg

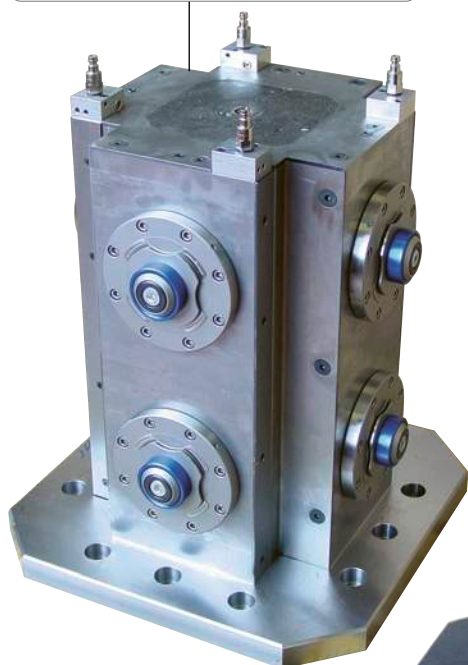

SMK24-24-42 OPP200 ~ 120 kg

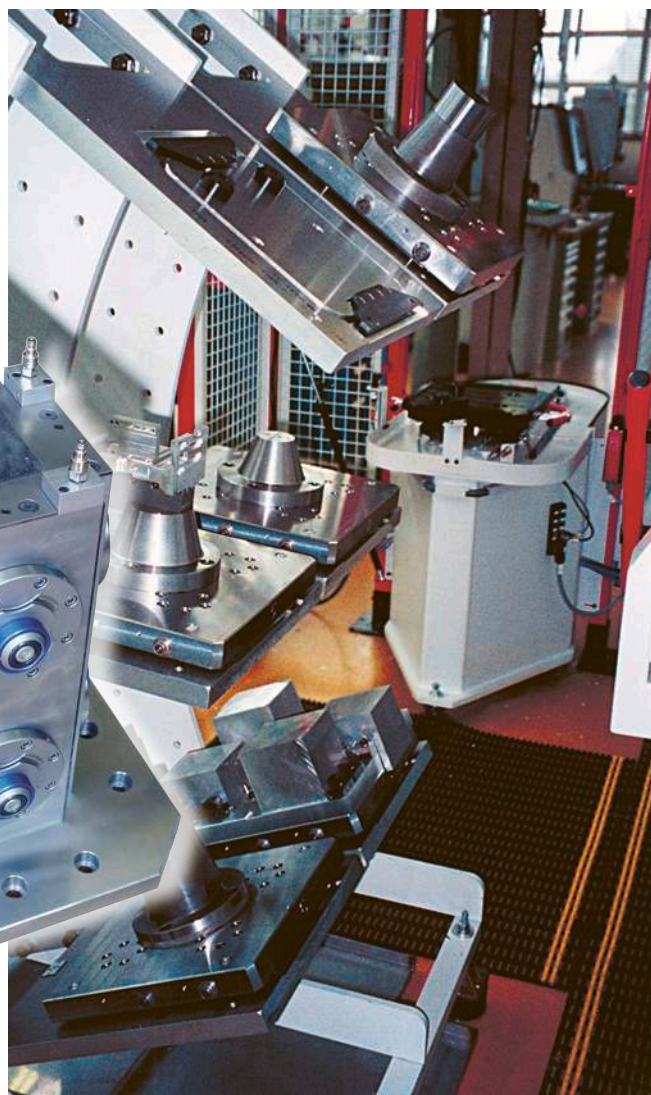
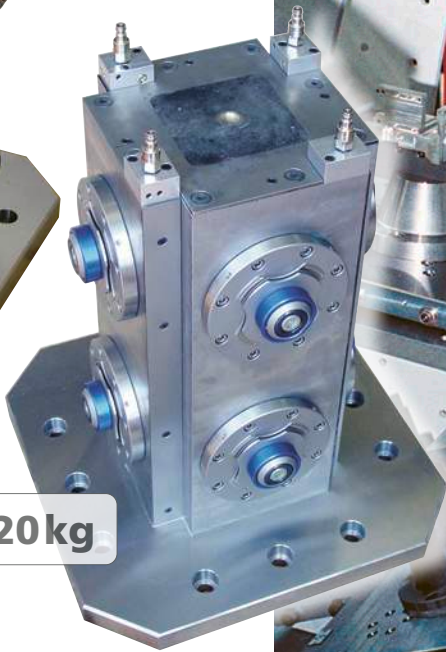

Mehr Informationen siehe Tripoxy Mineral
For more information check the Tripoxy Mineral p. 272

Nullpunkt-System OPP & Erowa MTS

In Verbindung mit dem Spannsystem powerCLAMP bilden die Nullpunkt-Paletten oppSysteme sehr kompakte, hochgenaue und schnell wechselbare Spannvorrichtungseinheiten.

Zentrischspanner mit OPP-Anschluss

Das neue mechanische 0-Punktsystem (**OPBM4Q100R50**) findet seine Einsatzmöglichkeiten in allen Bereichen.

Von der einfachen Schnellwechsepalette zur Einzelteilbearbeitung bis hin zur Mehrfachspannung in modernen Fräszentren.

Dank der hohen Wiederholgenauigkeit lassen sich Grossserien problemlos und in höchster Genauigkeit fertigen.

Zero-point system OPP & Erowa MTS

Together the modular system with zero point pallets, give a great performance! Fast changing and accurate!

Self centering vise with integrated zero point adaptation OPP

Because of its compact build body this self centering vise gives a perfect performance to automated 5 axis machines!

The index zero point system is built into the body of the vise, a sub pallet as you normally mount the vises!

The OPP system is a very accurate system reliable and durable! We guarantee 150'000 changes within $\pm 0,002\text{mm}$

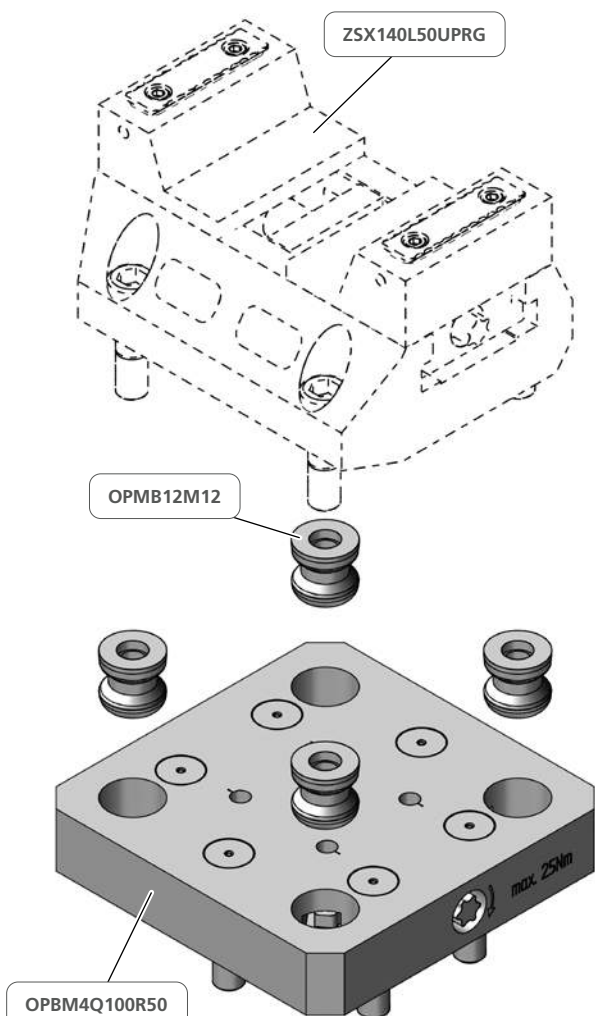

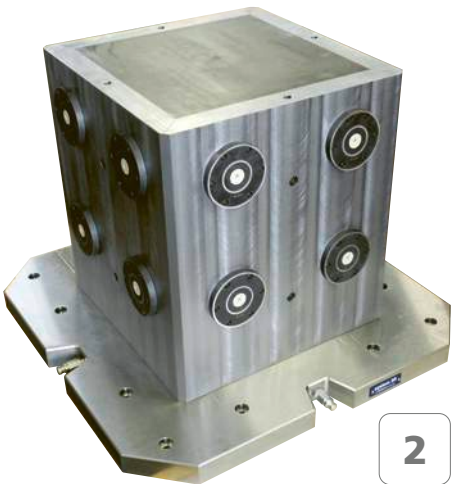

HORIZONTAL

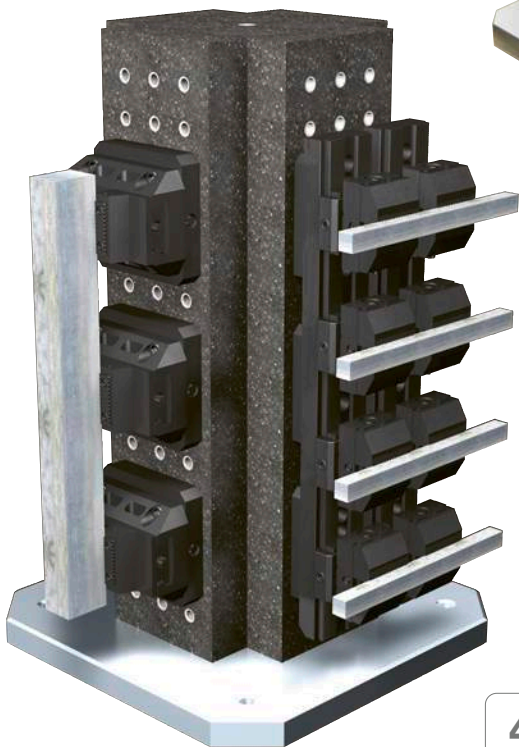

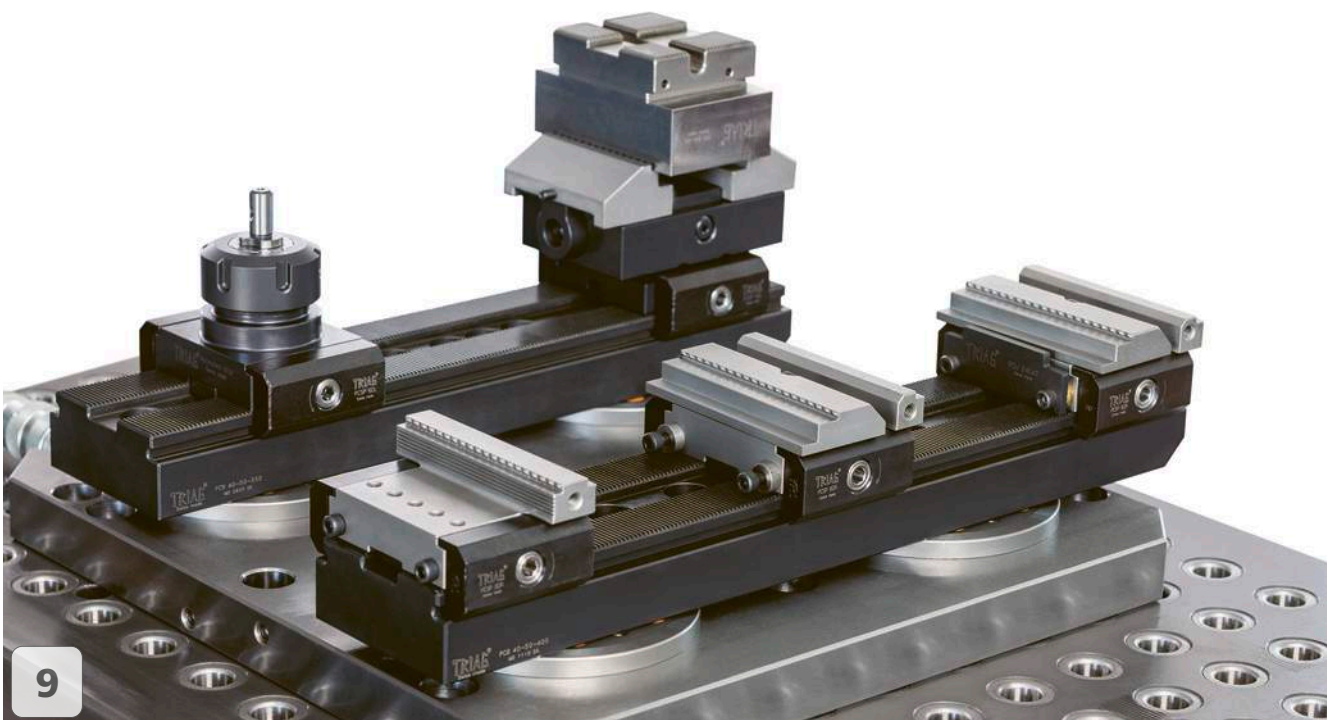
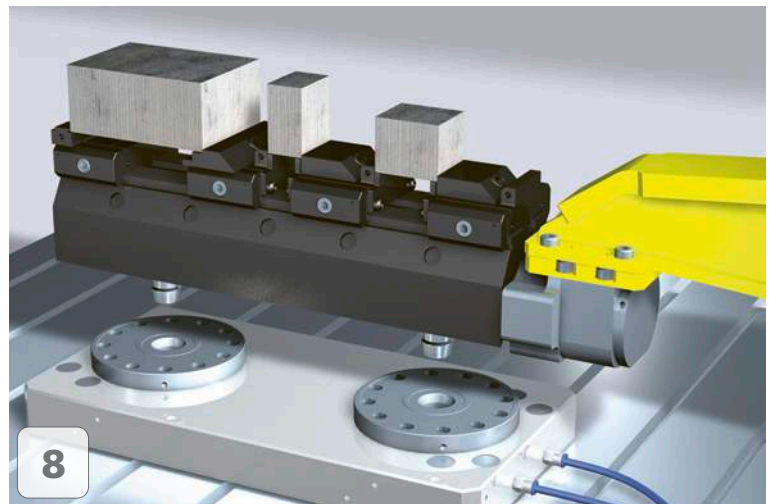
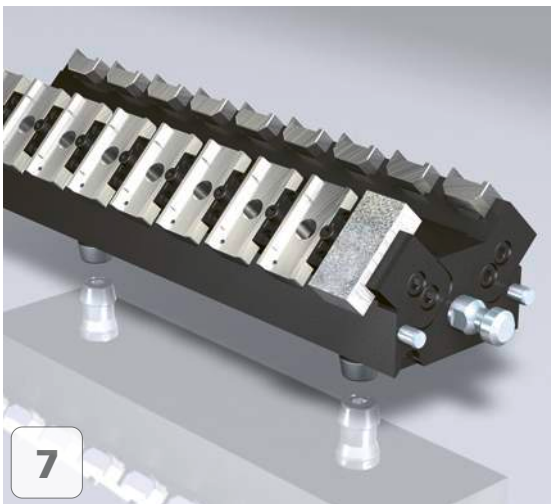

Mechanisches Nullpunktsystem mit diversen Spannlösungen

Mechanical zero point system with different workholding solutions

Da die Anforderungen an „just in time“ Produktion in den letzten Jahren stetig gewachsen sind, ist ein modulares Nullpunkt Schnellwechselsystem der richtige Weg um lange Standzeiten der Werkzeugmaschine zu verhindern.

Since the requirements for „just in time“ production have grown steadily in the recent years, a modular zero-point quick-change system is the right way to prevent long down time of a machine.

- ✓ **Sehr tiefe Bauhöhe (28 mm)**
- ✓ **Wiederholgenauigkeit 0.01 mm**
- ✓ **6000 dAN Haltekraft**
- ✓ **Abhebefunktion ein- und ausschaltbar (3-4 mm)**

- ✓ **Very low height (28mm)**
- ✓ **Repeat accuracy of 0.01mm**
- ✓ **6000daN holding force**
- ✓ **Lift-off function can be switched on and off (3-4 mm)**

triCENTRO p. 141

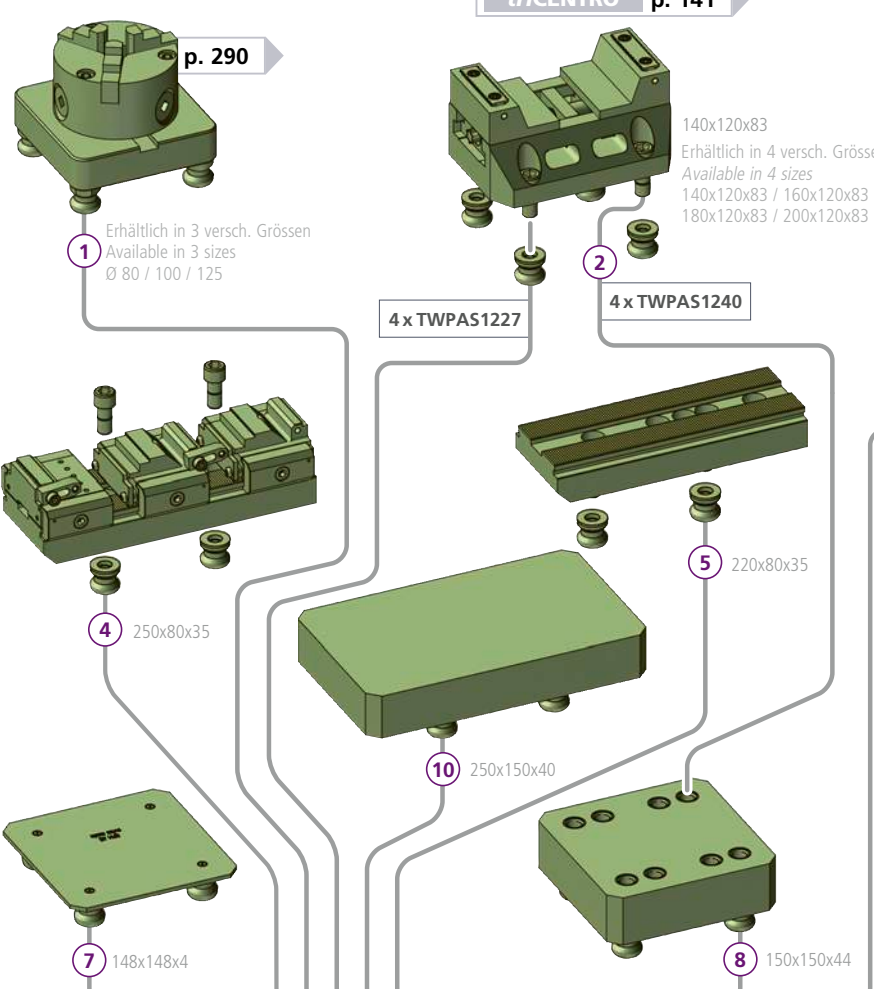

140x120x83
Erhältlich in 4 versch. Größen
Available in 4 sizes
140x120x83 / 160x120x83
180x120x83 / 200x120x83

triCENTRO p. 119

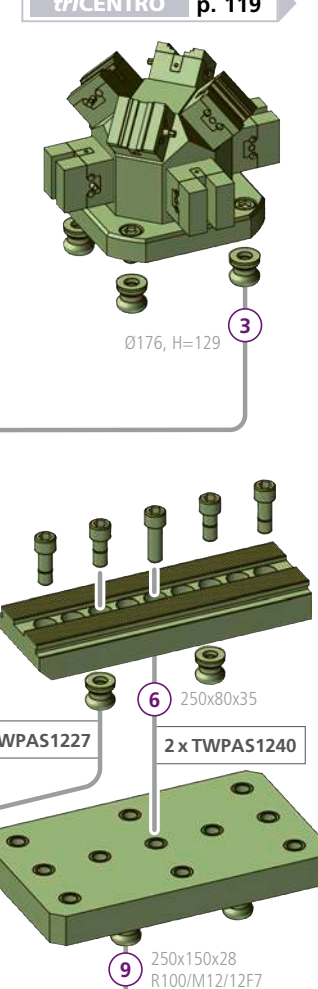

Ø176, H=129

p. 290

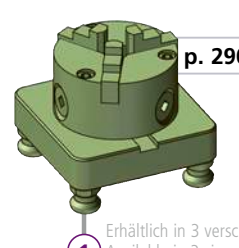

Erhältlich in 3 versch. Größen
Available in 3 sizes
Ø 80 / 100 / 125

4x TWPAS1227

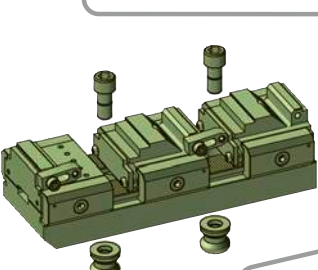

250x80x35

4x TWPAS1240

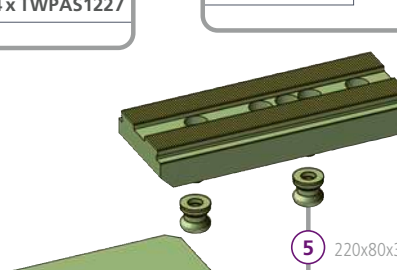

220x80x35

7

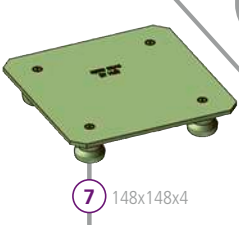

148x148x4

10

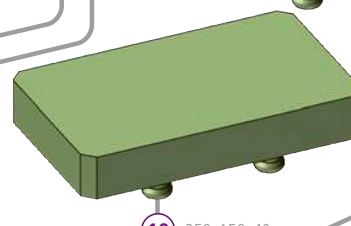

250x150x40

8

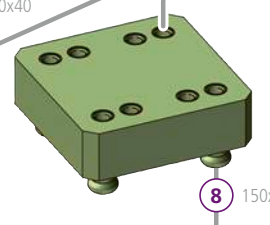

150x150x44

6

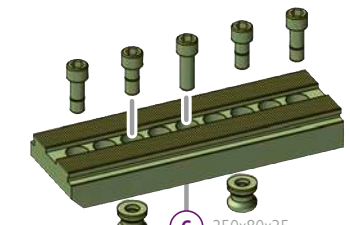

250x80x35

2x TWPAS1227

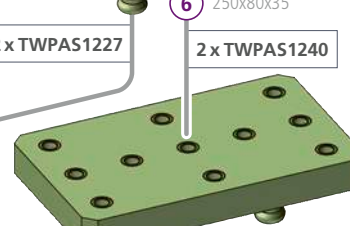

2x TWPAS1240

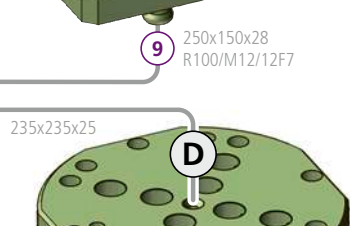

250x150x28
R100/M12/12F7

A

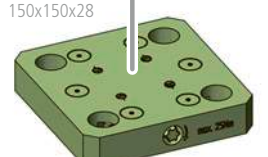

150x150x28

B



172x172x28

C

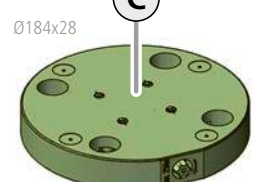

Ø184x28

D

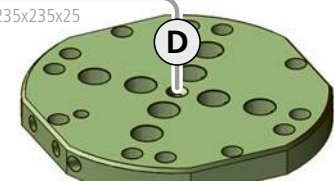

235x235x25

0-Punkt Basis / 0-point base kg

| | | |
|---|---------------|------|
| A | OPBM4Q100R50 | ~3,8 |
| B | OPBM4Q100R200 | ~7,6 |
| C | OPBM4Q100D184 | ~7,6 |
| D | ZF211785 | ~7,6 |

3-Backenfutter / 3-jaw chuck kg

| | | |
|---|-------------|------|
| | OPM3X80L75 | ~5,8 |
| 1 | OPM3X100L82 | ~7,3 |
| | OPM3X125L88 | ~9,5 |

Zentrischspanner / Self centering vise

| | Spannbereich / Clamping area | kg |
|---|------------------------------|-------------|
| 2 | ZSX140L50UPRG-OPM | 62-118 ~7,1 |
| | ZSX160L50UPRG-OPM | 62-138 ~7,7 |
| | ZSX180L50UPRG-OPM | 62-158 ~8,1 |
| | ZSX200L50UPRG-OPM | 62-178 ~8,8 |

spaceGRIP I kg

| | | |
|---|-----------------------|------|
| 3 | UB5AXMCZ4045SET8-OPBM | ~6,2 |
|---|-----------------------|------|

PowerCLAMP Set kg

| | | |
|---|------------------------|-------|
| 4 | PCSET18250-OPM | |
| | 1x PCSET18-250A / O3 | ~5,9 |
| | 2x PCSET18-L1 / B48-20 | ~2,65 |

Basisschiene diagonal / Baserail diagonal kg

| | | |
|---|------------------|------|
| 5 | PCSET18220W2-OPM | ~8,2 |
|---|------------------|------|

PC Schiene / PC Rail 250 mm kg

| | | |
|---|----------------|------|
| 6 | PCB2550250-OPM | ~4,8 |
|---|----------------|------|

Abdeckung / Cover kg

| | | |
|---|-------|------|
| 7 | OPMAD | ~0,8 |
|---|-------|------|

Erhöhung / Raiser block kg

| | | |
|---|------------|------|
| 8 | OPUB150H44 | ~8,5 |
|---|------------|------|

Rasterplatte / Grid plate kg

| | | |
|---|----------------|------|
| 9 | OPM25-15R50H28 | ~7,7 |
|---|----------------|------|

Aluminiumplatte / Aluminium plate kg

| | | |
|----|--------------|------|
| 10 | OPM25-15RH40 | ~4,3 |
|----|--------------|------|

| | | |
|----------------------|------|---|
| Art. Nr. | kg |  |
| OPBM4Q100R200 | ~4,3 | |

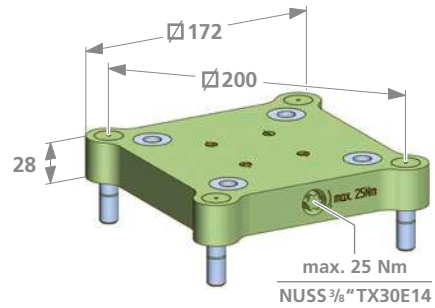

| | | |
|----------------------|------|---|
| Art. Nr. | kg |  |
| OPBM4Q100D184 | ~4,7 | |

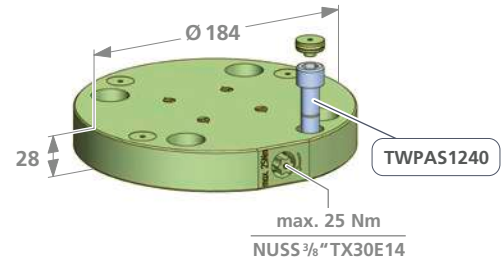

| | | |
|---------------------|------|--|
| Art. Nr. | kg |  |
| OPBM4Q100R50 | ~3,8 | |

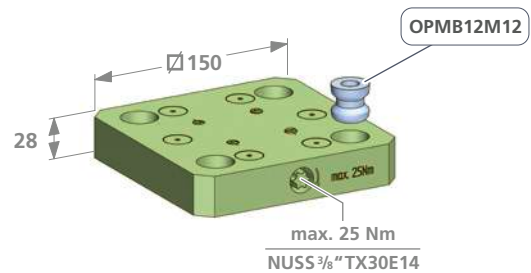

Positionier-Flansch
Positioning-flange

| | | | | |
|-----------------|-----|-----|------|---|
| Art. Nr. | A | Ø | kg |  |
| ZF211785 | 235 | 250 | ~7,6 | |
| ZF222333 | 172 | 180 | ~3,7 | |

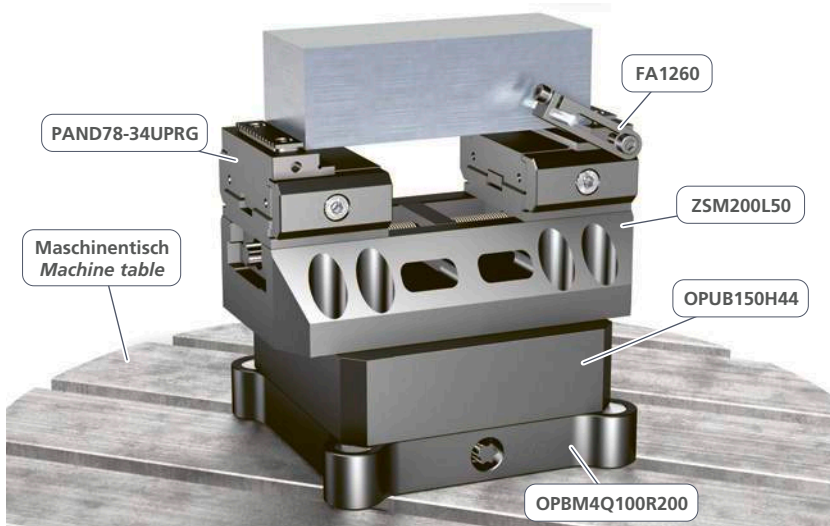
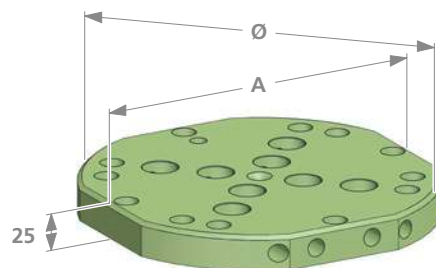

Die Verbindung zwischen Maschinentisch und dem opp-Schnellwechselsystem
 The connection between the machine table and the opp-quick-change system

4-Achs Lösung für mechanische 0-Punkt Schnellwechselsysteme

4-axis solution for mechanical 0-point quick change systems

oppSystem

Winkel für die 4-Achse
Angle for the 4-axis

| Art. Nr. | Y | kg |
|--------------|-----|-------|
| WU-18 | 180 | ~14,1 |
| WU-25 | 244 | ~16 |

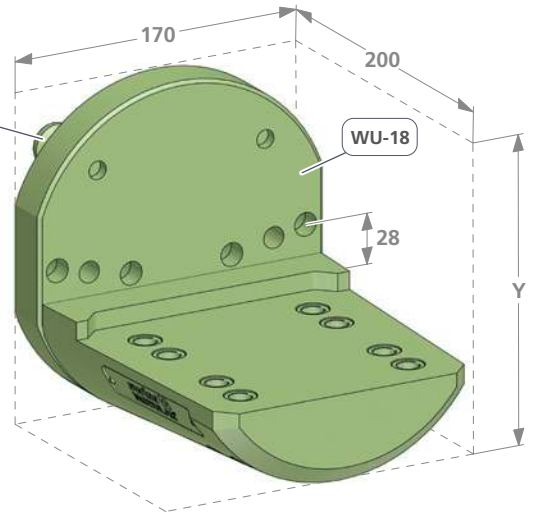
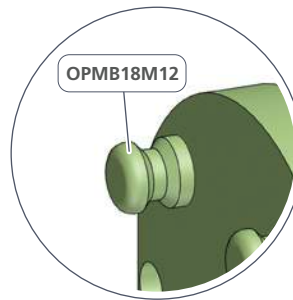

Flansch / Flange
Optional erhältlich
Optional accessory

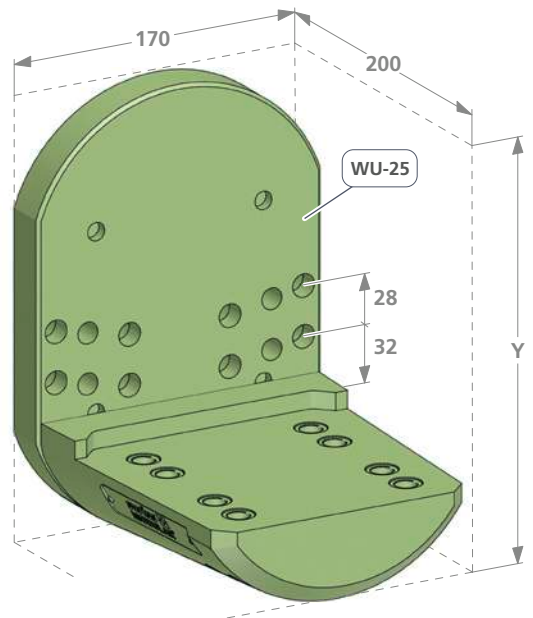
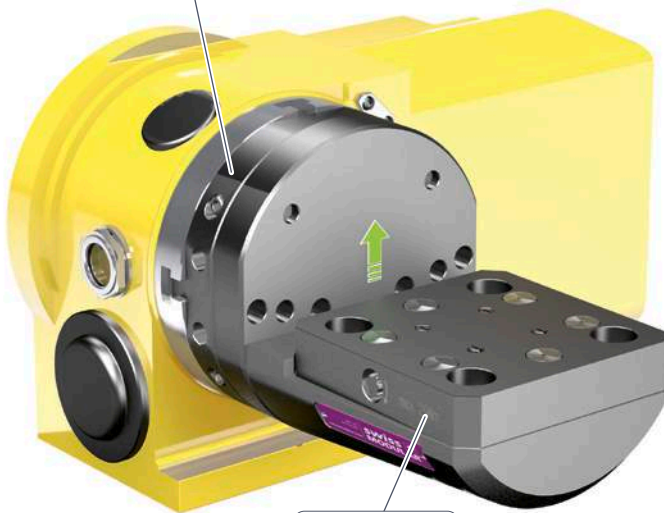

Bei diesen Winkeln kann die Brücke für die Aufnahme der Spannmittel inklusive Werkstücke in der Höhe angepasst werden.

With these angles, the bridge can be adjusted in height to accommodate the clamping devices including workpieces.

0-Punkt Erhöhung & Ausrichtplatte Zero point riser & Alignment plate

0-Punkt Erhöhung Zero point riser

| Art. Nr. | kg |
|-------------------|------|
| OPUB150H44 | ~8,5 |



Optimal kombinierbar mit der Erhöhung (OPUB150H44) für eine bessere Zugänglichkeit zum Werkstück.

Ideally combined with the riser (OPUB150H44) for better access to work piece.

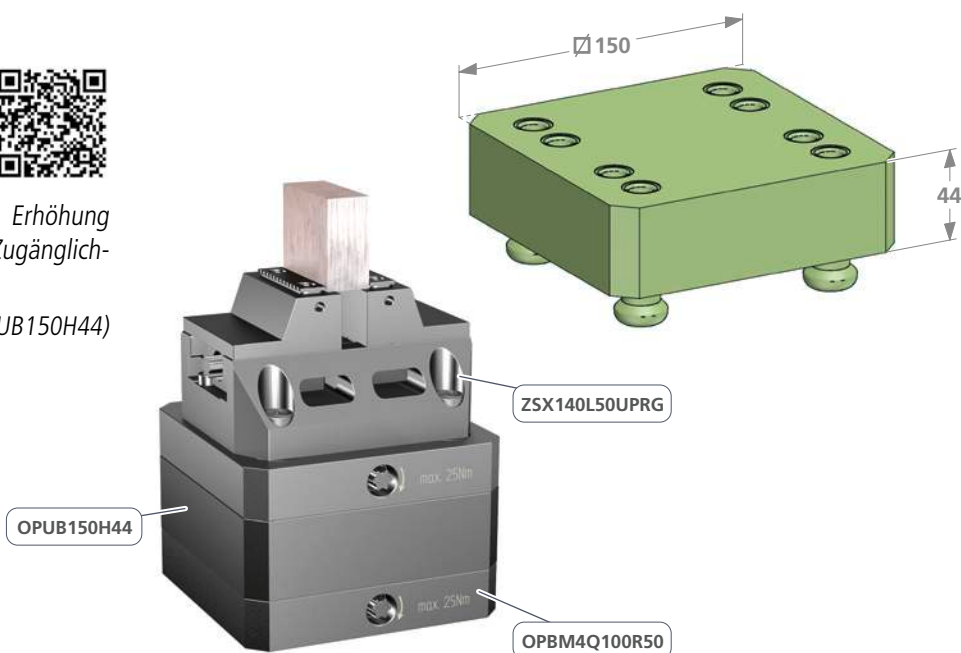

Ausrichtplatte Alignment plate

| Art. Nr. | kg |
|--------------|-------|
| OPMAW | ~3,54 |

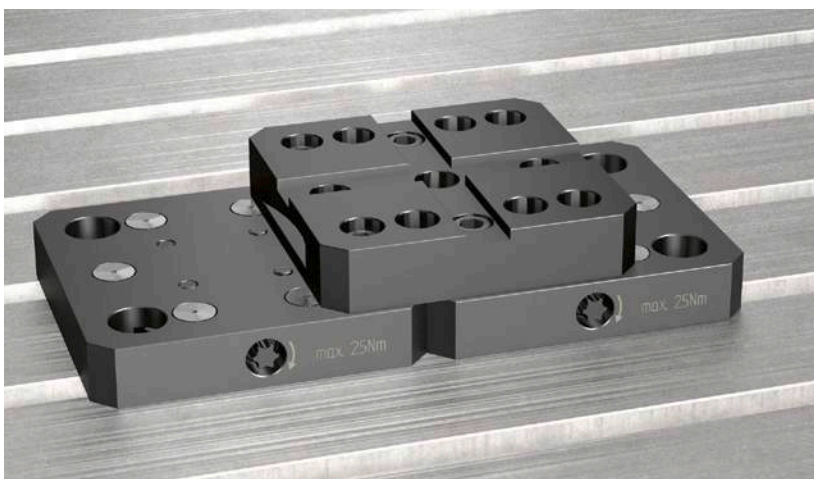
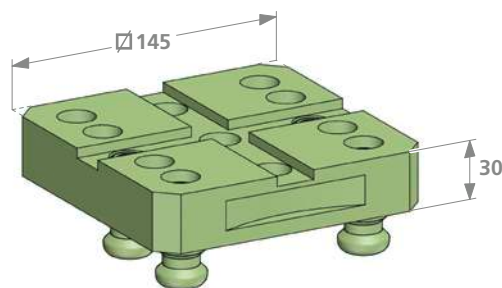

Diese Platte dient zum Ausrichten dem T-Nutentisch.

This plate is used to align on the T-slot table.

| Nullpunkt Zentrier- und Klemmbolzen Zero point pull studs | | Nullpunkt Schwertbolzen Diamond pull studs | | Klemmbolzen mit Untermass Pull studs with minus tolerance | | Schutzbolzen Protection bolts | | | |
|--|-----------------------|---|------------------------|--|------------------------|----------------------------------|-------------------|--|----------------------|
| | kg ~0,1 OPMB18M12 | | kg ~0,1 OPMB18M12S | | kg ~0,1 OPMB18M12U | | kg ~0,08 OPMBL | | kg ~0,07 OPMBL-25 |
| | kg ~0,06 OPMB12M12 | | kg ~0,06 OPMB12M12S | | kg ~0,06 OPMB12M12U | | kg ~0,08 OPMBL | | kg ~0,07 OPMBL-25 |

Dreibackenfutter
Three-jaw chuck

OPM3X80L75
OPM3X100L82
OPM3X125L88

oppSystem

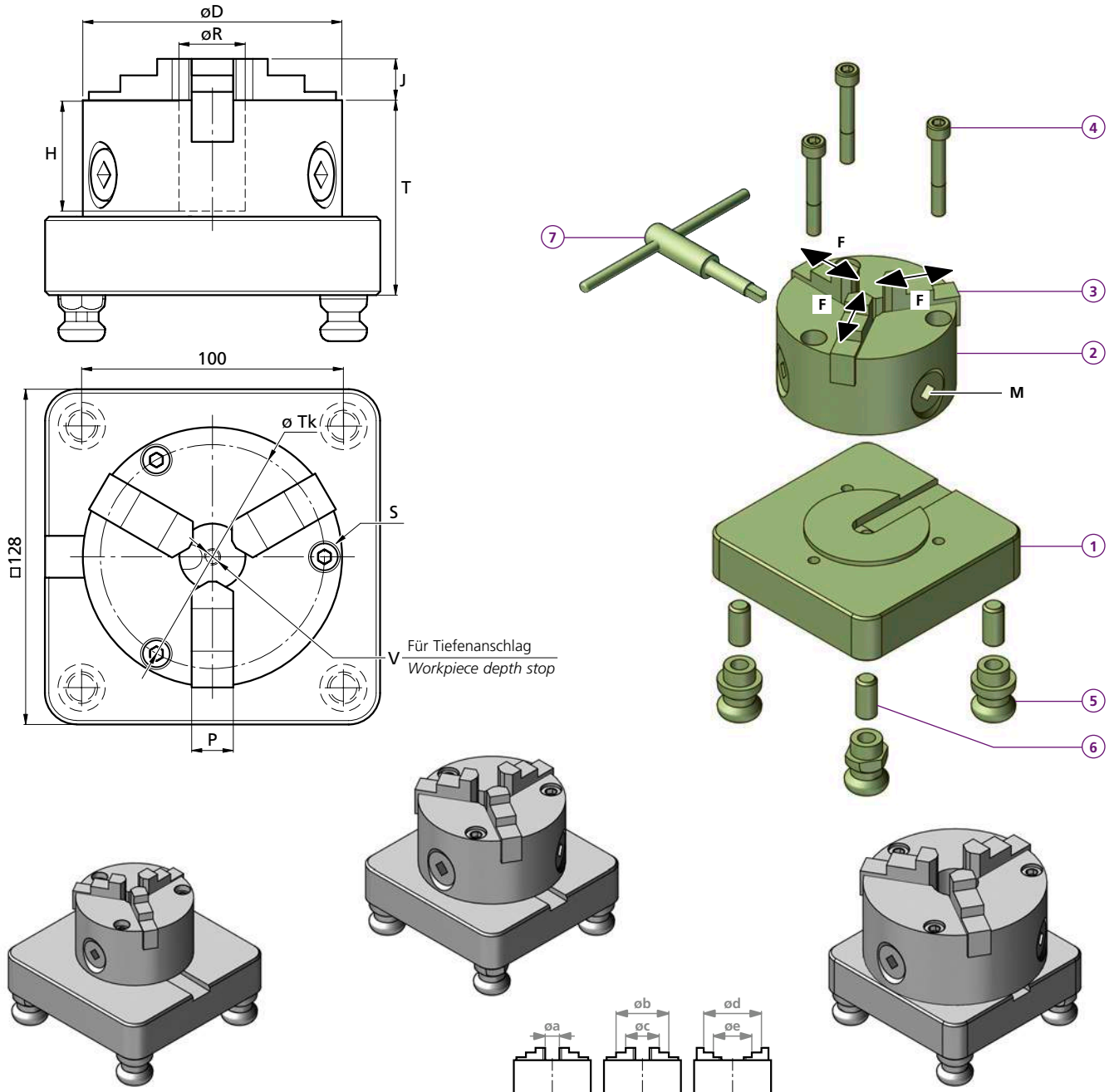

| | D | J | T | R | H | P | V | a mm | b mm | c mm | d mm | e mm | M (max.) | F (max.) | $\varnothing Tk$ | S |
|--------------------|-----|----|----|----|------|----|----|--------|----------|---------|----------|---------|----------|----------|------------------|----|
| OPM3X80L75 | 80 | 13 | 75 | 15 | 42,5 | 10 | M6 | 3...27 | 48...73 | 23...48 | 52...76 | 27...51 | 28 Nm | 1300 daN | 67 | M6 |
| OPM3X100L82 | 100 | 17 | 82 | 20 | 49,5 | 14 | M8 | 3...39 | 58...94 | 24...60 | 64...100 | 30...66 | 38 Nm | 1600 daN | 83 | M8 |
| OPM3X125L88 | 125 | 19 | 88 | 32 | 55 | 16 | M8 | 3...49 | 70...116 | 30...75 | 83...125 | 38...84 | 55 Nm | 2600 daN | 108 | M8 |

| OPM3X80L75 | OPM3X100L82 | OPM3X125L88 |
|---------------------|---------------------|---------------------|
| 1 1x TB161207 | 1 1x TB161208 | 1 1x TB161209 |
| 2 1x 243809.0083220 | 2 1x 243809.0103220 | 2 1x 243809.0123220 |
| 3 2x 3 Stk. / pcs | 3 2x 3 Stk. / pcs | 3 2x 3 Stk. / pcs |
| 4 3x TN100346 | 4 3x TN100360 | 4 3x TN100361 |
| 5 1x OPMB18M12 | 5 1x OPMB18M12 | 5 1x OPMB18M12 |
| 2x OPMB18M12U | 2x OPMB18M12U | 2x OPMB18M12U |
| 1x OPMB18M12S | 1x OPMB18M12S | 1x OPMB18M12S |
| 6 4x TN100067 | 6 4x TN100067 | 6 4x TN100067 |
| 7 1x 243864.0080000 | 7 1x 243864.0100000 | 7 1x 243864.0120000 |
| kg ~ 5,8 | kg ~ 7,3 | kg ~ 9,5 |

243849.0083200 243850.0083200 *243834.0083300

243849.0103200 243850.0103200 *243834.0103300

243849.0123200 243850.0123200 *243834.0123300

3x $\varnothing 3 - 49$

3x $\varnothing 38 - 125$

3x *Weich Soft 16MnCr5

Separat bestellen / Order separately

Bestellbeispiel / Ordering example: **OPM3X80L75**

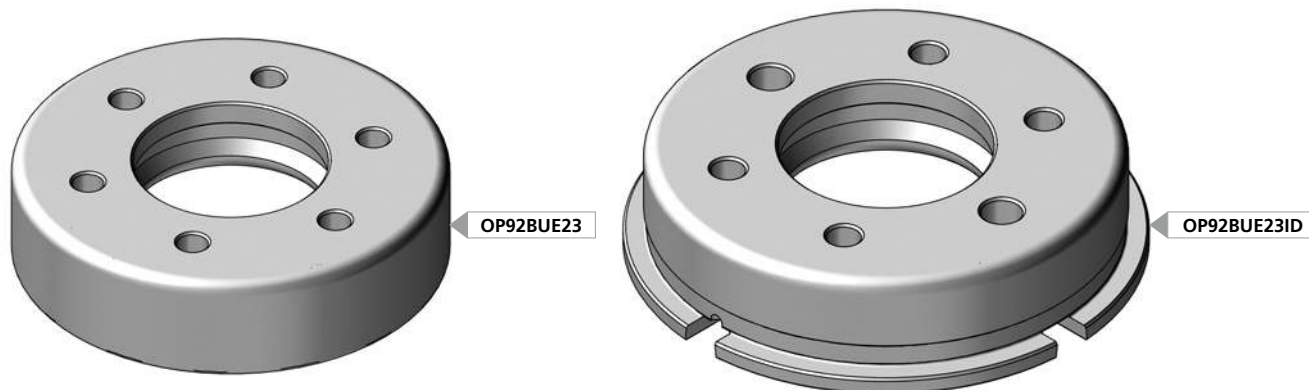

| | kg |
|-------------|-------|
| OP92BUE23 | ~0,75 |
| OP92BUE23ID | ~0,78 |

Bestellbeispiel / Ordering example: **OP92BUE23**

Einbauanleitung / Assembling instructions

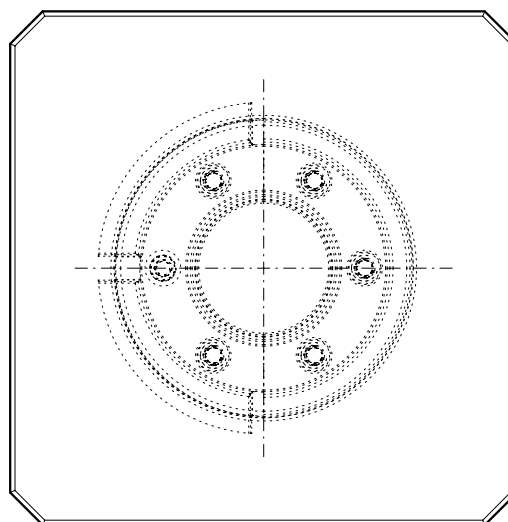
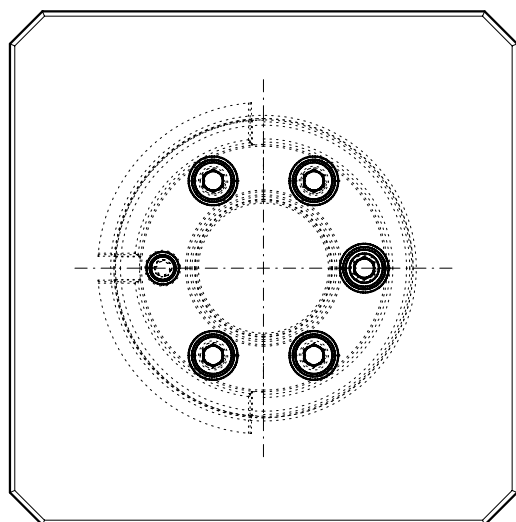
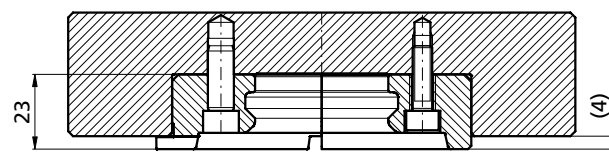
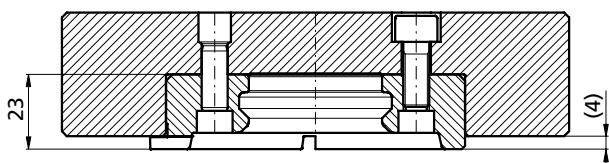
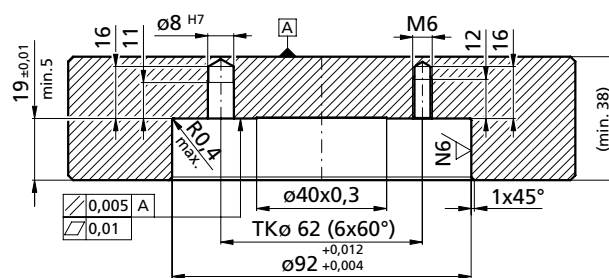
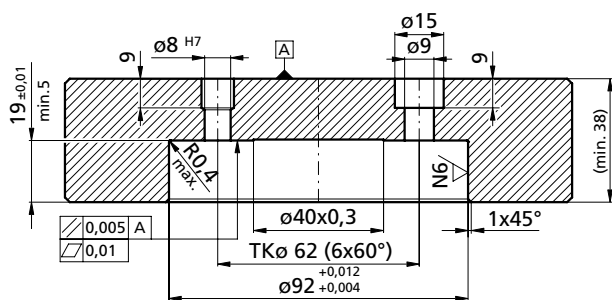

Zentriereinheit
Chuck unit

Zentrierkörper
Chuck body

oppSystem

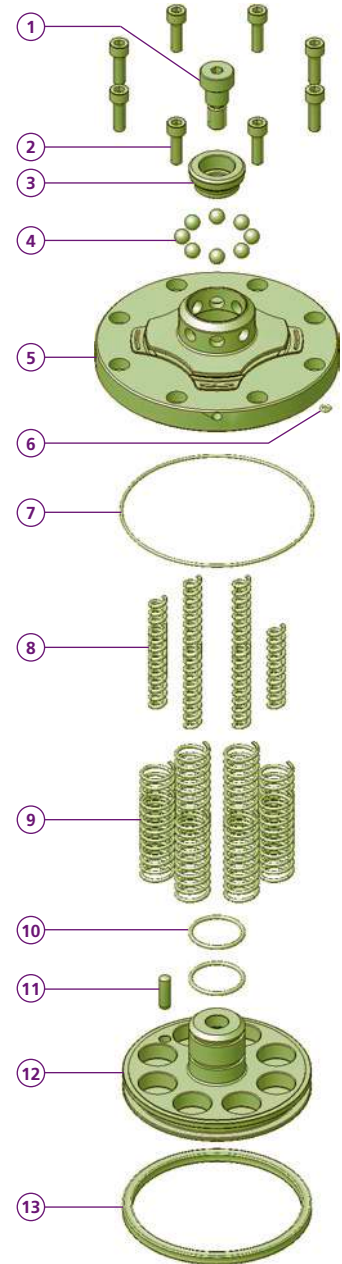
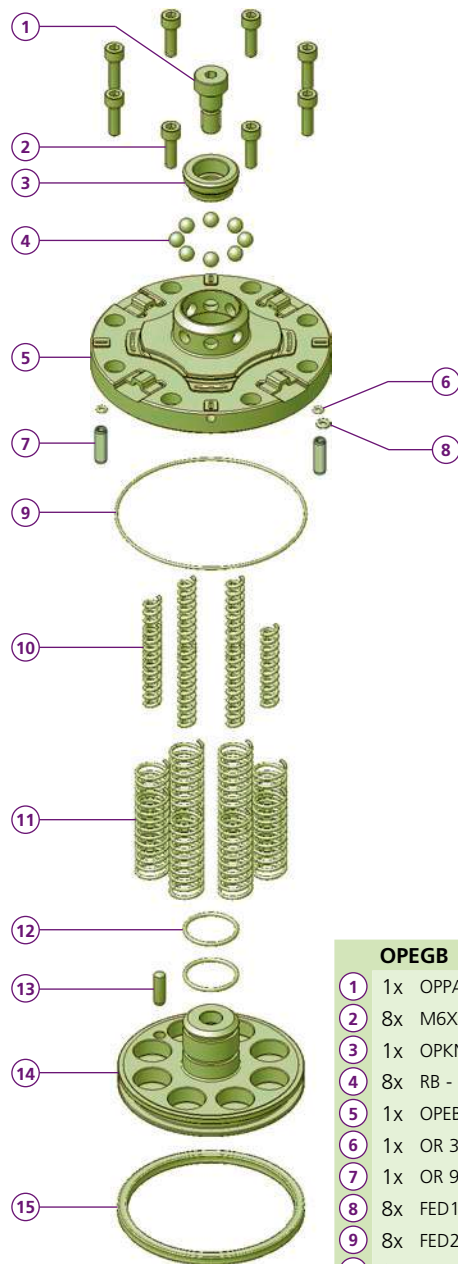
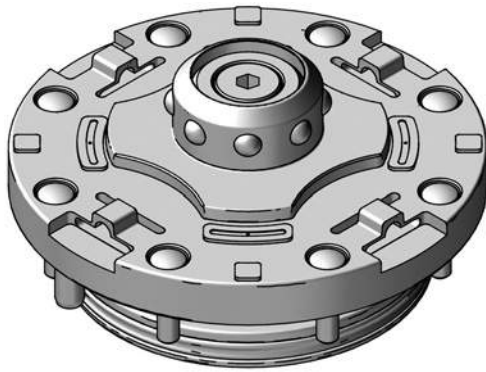

OPEGBID (Index)

- ① 1x OPPAS M10x12
- ② 8x M6X20 ST
- ③ 1x OPKN 30x13,5
- ④ 8x RB - 8/G20W
- ⑤ 1x OPEBID
- ⑥ 1x OR 3x1,5
- ⑦ 2x **CCBO0801**
- ⑧ 1x OR 5x1,5
- ⑨ 1x OR 90x1,5
- ⑩ 8x FED1044
- ⑪ 8x FED2051
- ⑫ 2x OR 26x2
- ⑬ 1x 6m6x20 DIN 6325
- ⑭ 1x OPKLB100
- ⑮ 1x OPDR885

kg ~2,28

OPEGB

- ① 1x OPPAS M10x12
- ② 8x M6X20 ST
- ③ 1x OPKN 30x13,5
- ④ 8x RB - 8/G20W
- ⑤ 1x OPEB
- ⑥ 1x OR 3x1,5
- ⑦ 1x OR 90x1,5
- ⑧ 8x FED1044
- ⑨ 8x FED2051
- ⑩ 2x OR 26x2
- ⑪ 1x 6m6x20 DIN 6325
- ⑫ 1x OPKLB100
- ⑬ 1x OPDR885

kg ~2,26

Bestellbeispiel
Ordering example: OPEGBID

1er Palettenträger

Receiver chuck with 1 chucks

oppSystem

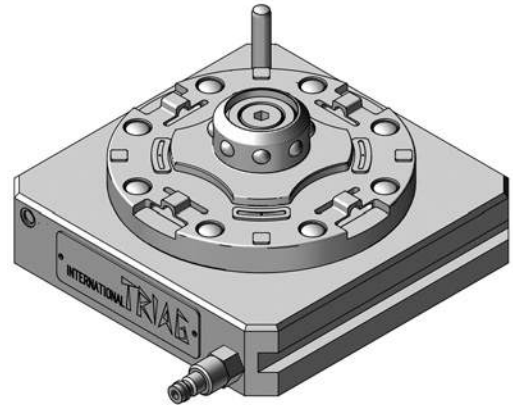
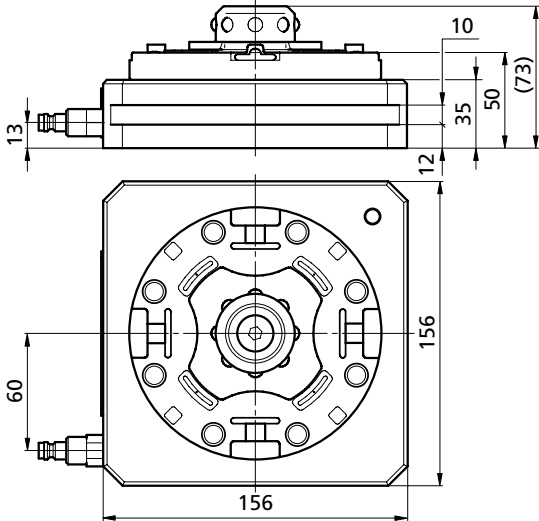

Bestellbeispiel / Ordering example : **OPB1ID**

| | kg |
|----------------|------|
| OPB1ID (Index) | ~8,0 |

1er Palette

Pallet with 1 clamping case

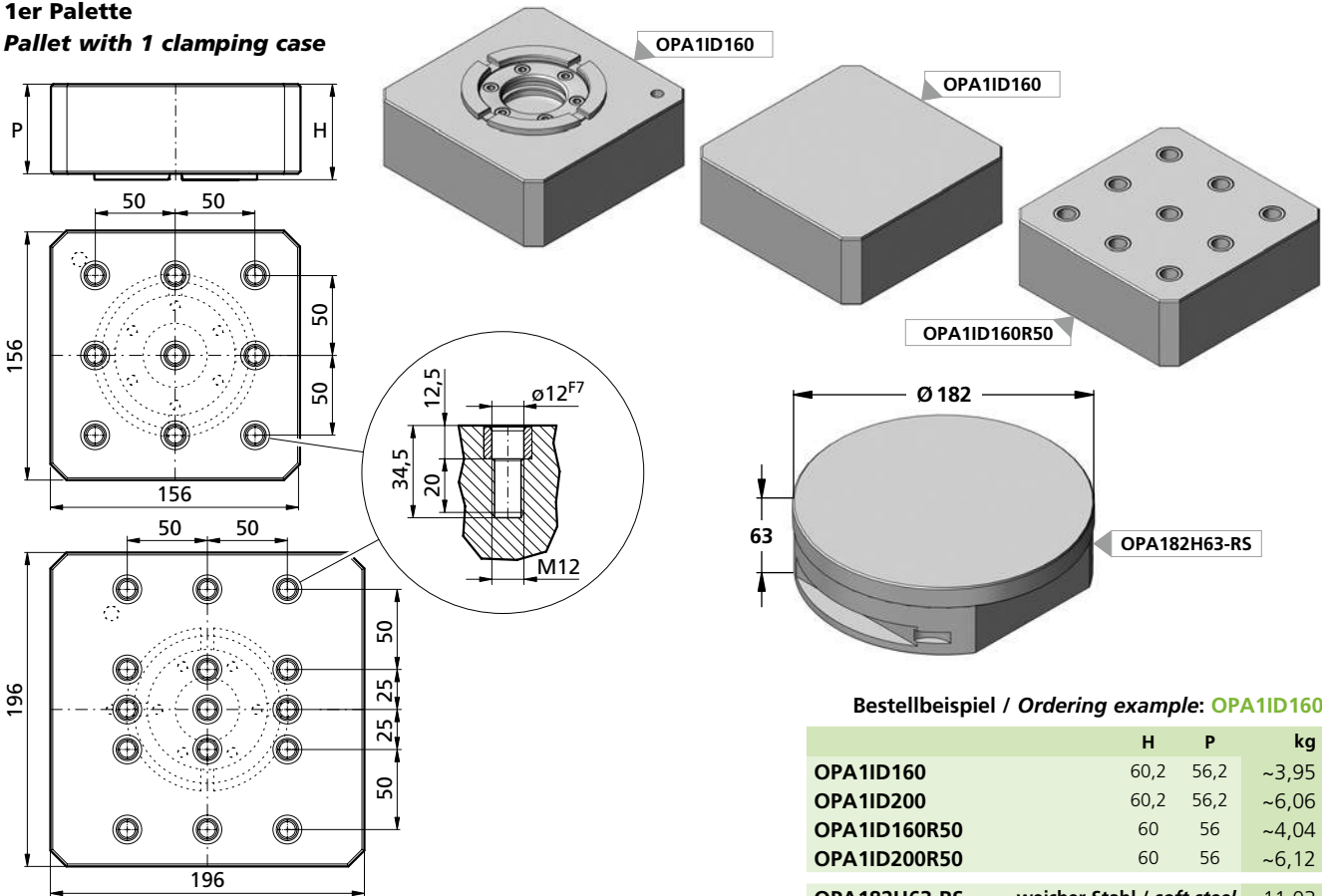

Bestellbeispiel / Ordering example: **OPA1ID160**

| | H | P | kg |
|--------------|------------------------------|------|--------|
| OPA1ID160 | 60,2 | 56,2 | ~3,95 |
| OPA1ID200 | 60,2 | 56,2 | ~6,06 |
| OPA1ID160R50 | 60 | 56 | ~4,04 |
| OPA1ID200R50 | 60 | 56 | ~6,12 |
| OPA182H63-RS | = weicher Stahl / soft steel | | ~11,03 |

Basis mit integrierter 0-Punkt Index Aufnahme oppSystem

Base rail with integrated oppSystem index

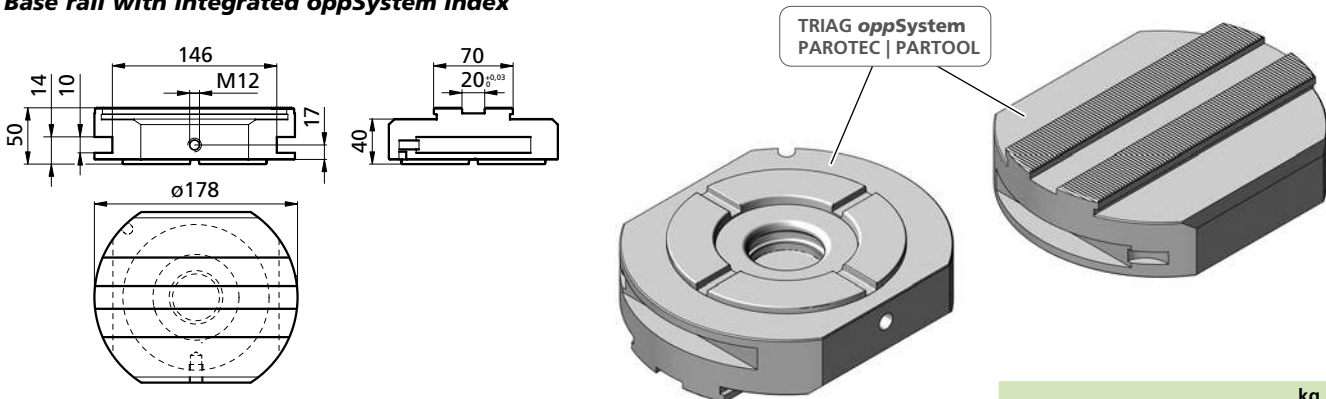

Bestellbeispiel / Ordering example: **OPA1IDPCB178**

| | kg |
|---------------|------|
| OPA1IDPCBD178 | ~7,0 |

2er Palettenträger

Receiver chuck with 2 chucks

oppSystem

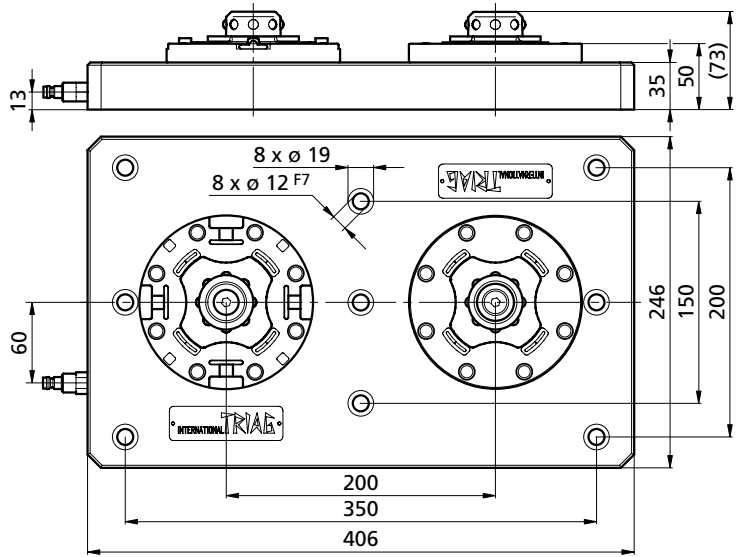
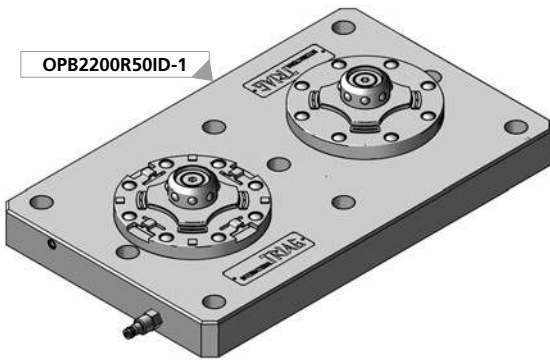
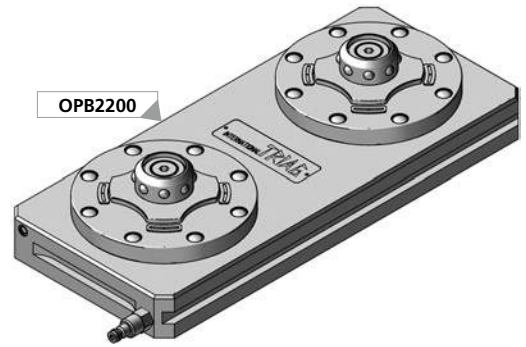
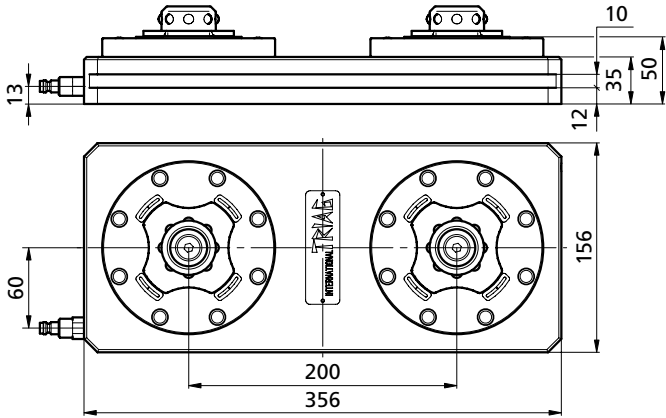

| | kg |
|------------------------|--------|
| OPB2200 | ~17,50 |
| OPB2200R50 | ~30,00 |
| OPB2200R50ID-1 (Index) | ~30,00 |
| OPB2200R50ID-2 (Index) | ~30,00 |

Bestellbeispiel / Ordering example: **OPB2160**

2er Palette

Pallet with 2 clamping case

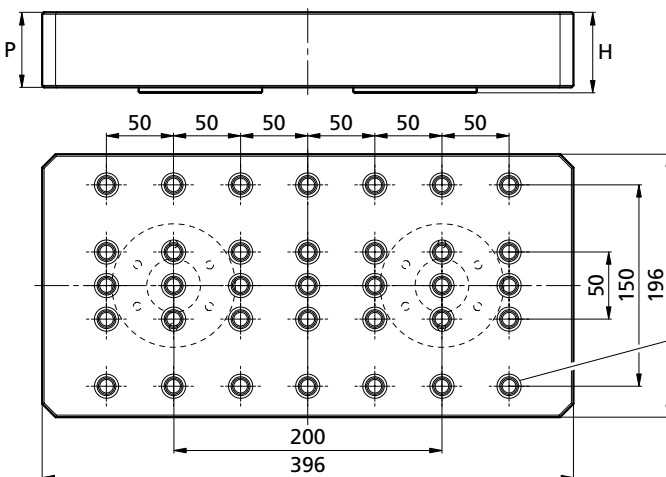
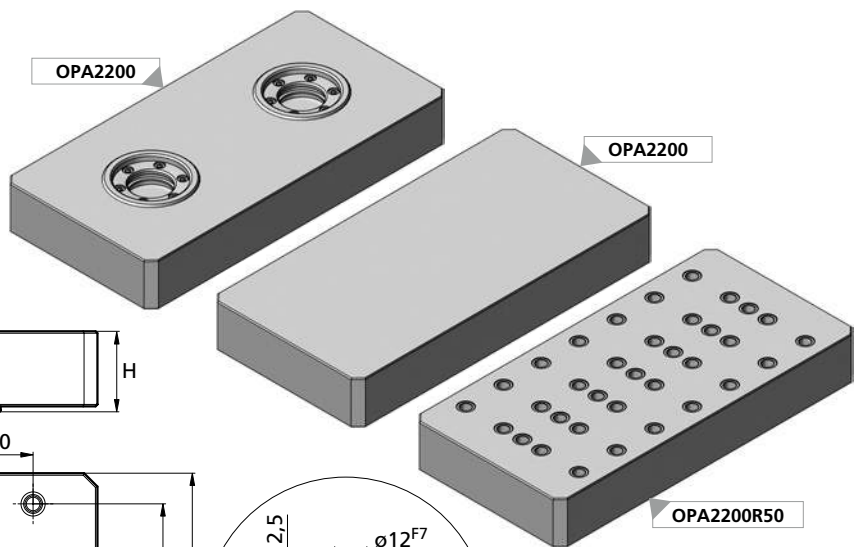

| | H | P | kg |
|------------|------|------|--------|
| OPA2200 | 60,2 | 56,2 | ~12,18 |
| OPA2200R50 | 60 | 56 | ~12,32 |

Bestellbeispiel / Ordering example: **OPA2200R50**

3er Palettenträger

Receiver chuck with 3 chucks

oppSystem

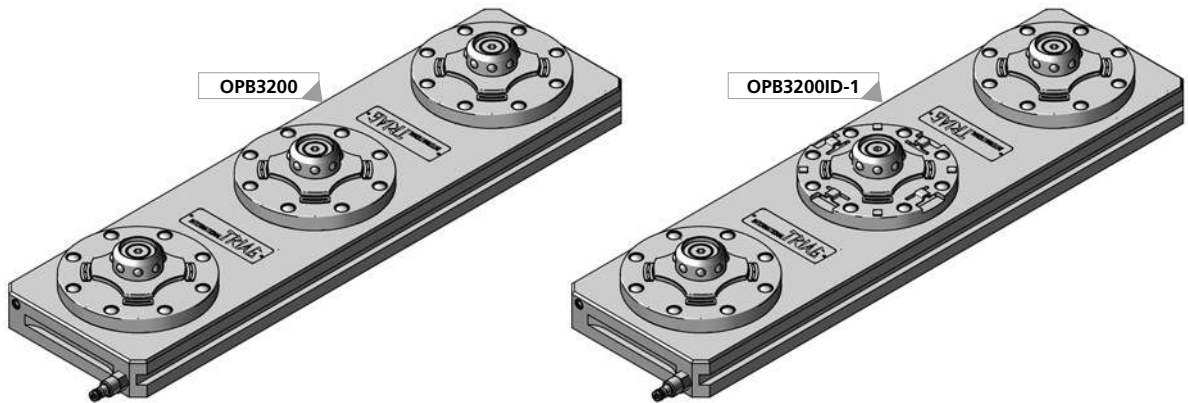
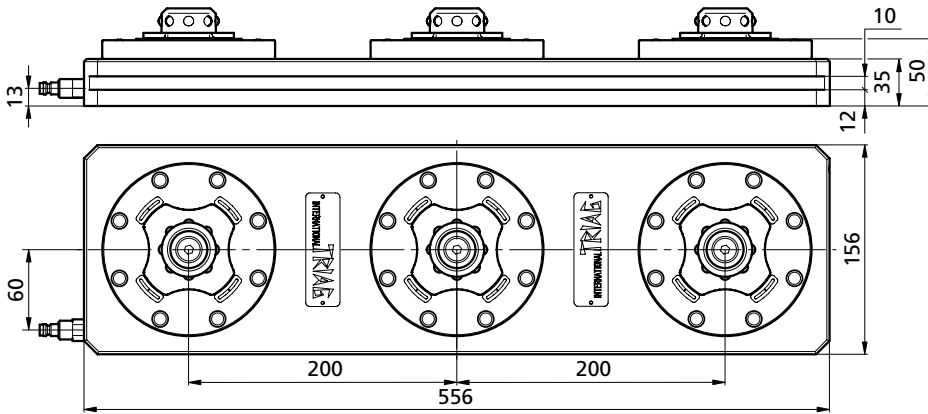

| | kg |
|---------------------|--------|
| OPB3200 | ~27,00 |
| OPB3200ID-1 (Index) | ~27,00 |

Bestellbeispiel / Ordering example: OPB3200

3er Palette

Pallet with 3 clamping case

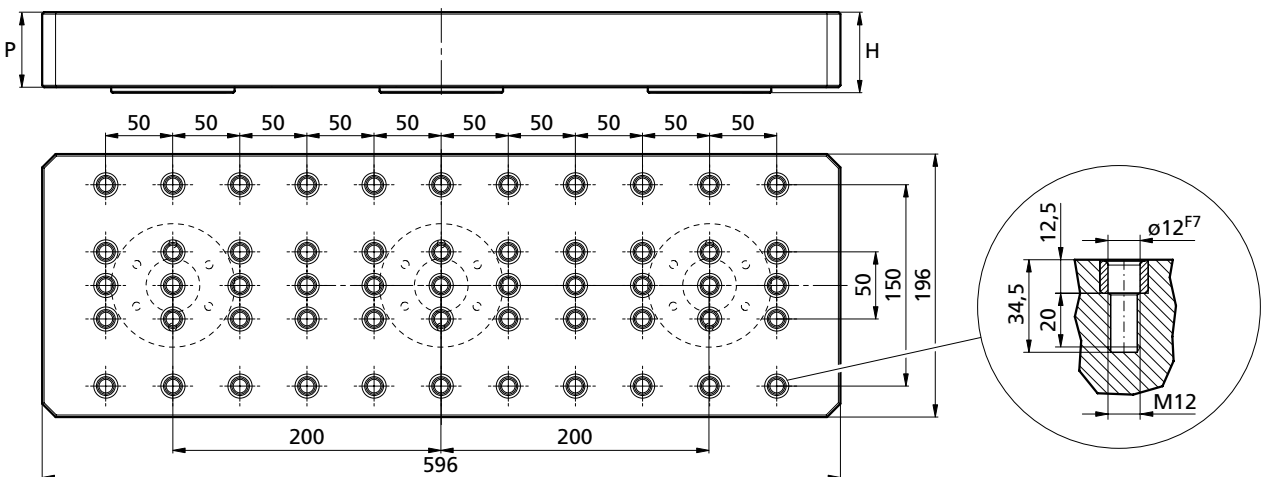
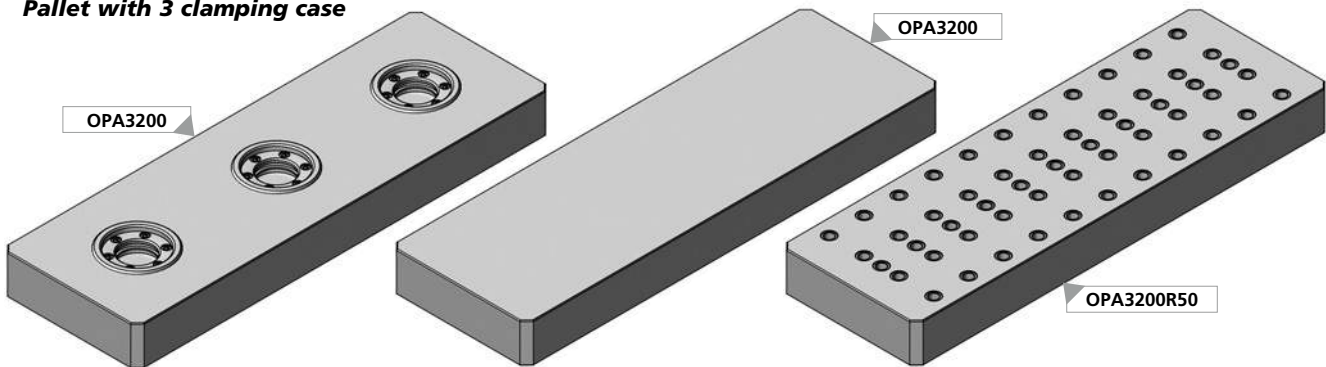

| | H | P | kg |
|------------|------|------|--------|
| OPA3200 | 60,2 | 56,2 | ~18,36 |
| OPA3200R50 | 60 | 56 | ~18,57 |

Bestellbeispiel / Ordering example: OPA3200

4er Palettenträger Receiver chuck with 4 chucks

oppSystem

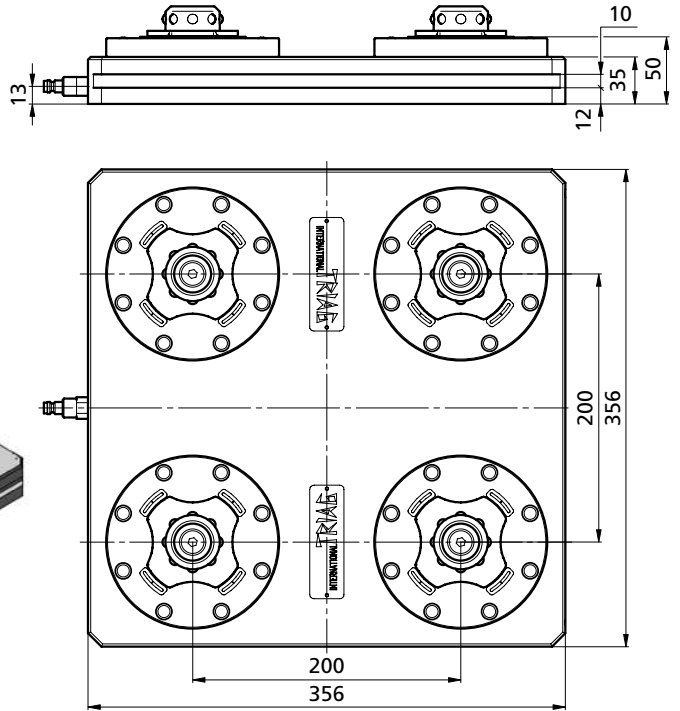

| | kg |
|--------------|--------|
| OPB4Q200 | ~39,00 |
| OPB4Q200ID-4 | ~39,00 |

Bestellbeispiel / Ordering example: **OPB4Q200**

4er Palette Pallet with 4 clamping case

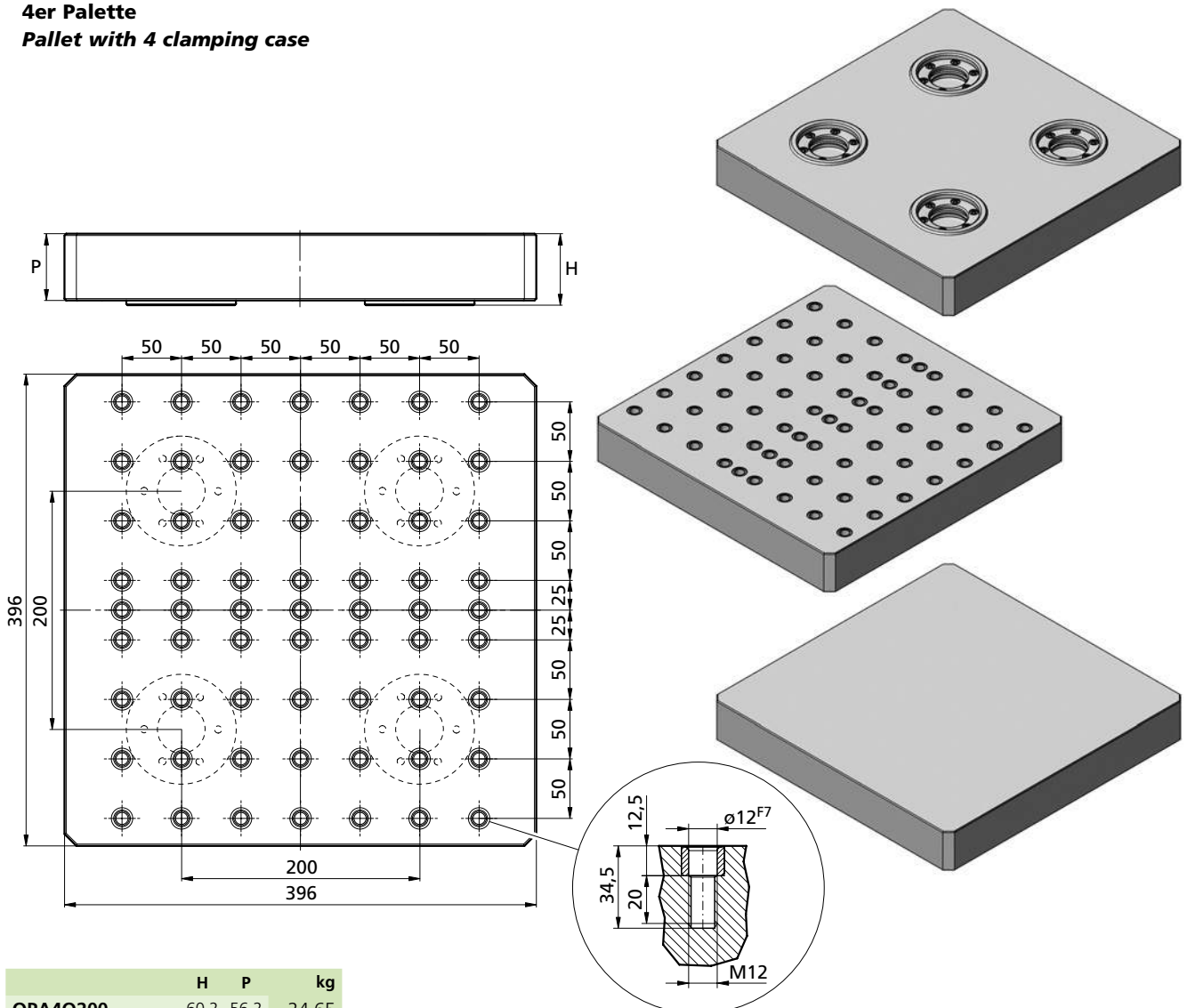

| | H | P | kg |
|-------------|------|------|--------|
| OPA4Q200 | 60,2 | 56,2 | ~24,65 |
| OPA4Q200R50 | 60 | 56 | ~24,88 |

Bestellbeispiel / Ordering example: **OPA4Q200**

EROWA MTS Einbauspannfutter / Integral chucks

Einbauvariante (gültig für MTS IntegralChuck Single und Multi). Toleranzen entsprechend der Einbauanleitung beachten!

Integration variant (applicable to MTS IntegralChucks Single and Multi). Observe tolerances according to integration instructions!

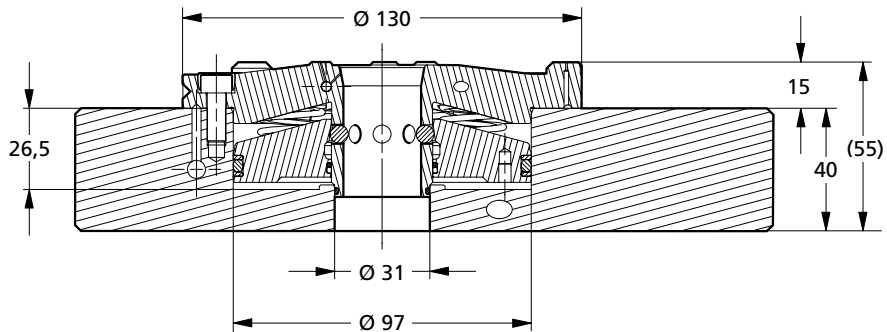

Manuelle Bedienung
Manual operation



Geeignet zur Anwendung unter Flüssigkeit
Suited for submerged operation



Geeignet für automatische Anwendung
Suited for automatic operation



Mit Druckluftpistole bedienen
Operate with compressed air jet



Für spanabhebende Bearbeitung
For chip-removing processes



Zum Senkerodieren
For EDM sinking

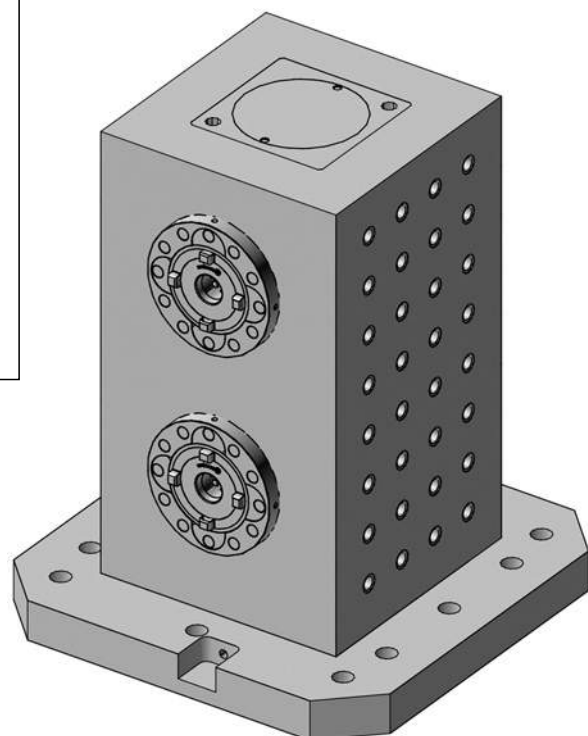

1 Präzise

Spielfreie Kurzkegel-Zentrierung.
 Repetiergenauigkeit: < 0,005 mm.
 Leichtes Einfahren der Paletten.

2 Spannmechanismus

Zuverlässiger Spannmechanismus durch selbsthemmenden Kugelverschluss.

3 Öffnen

MTS Spannfutter werden pneumatisch betätigt.

4 Sauberkeit

Flüssigkeit kann ablaufen, keine Schmutzecken.

1 Precise

Play-free round-cone centering.
 Repeatability: <0.005 mm.
 Easy insertion of the pallets.

2 Clamping mechanism

Reliable clamping mechanism through self-locking ball lock.

3 Open

MTS are operated pneumatically.

4 Cleanliness

Liquids can drain off. No dirt traps.

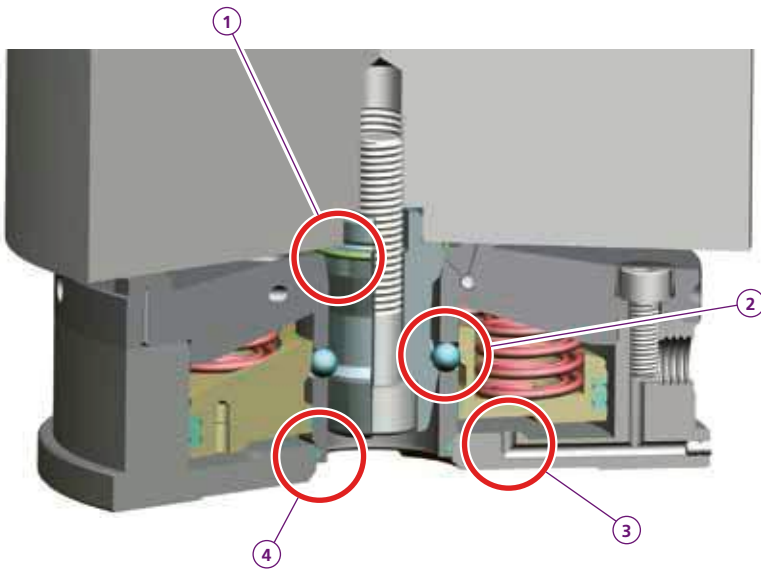

L x B x H: Maschinenabhängig
L x W x H: Depending on the machine

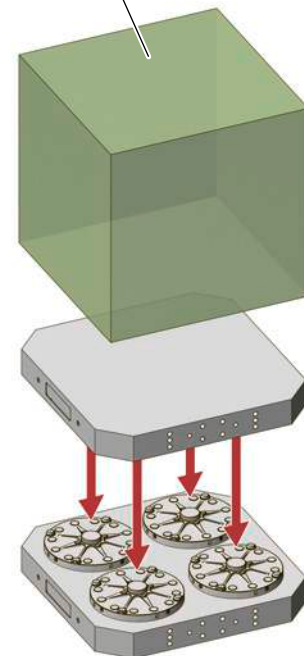

MTS Spannfutter

Das pneumatische MTS Spannfutter benötigt trotz der hohen Spannkraft von 12'000 N dank interner Kraftverstärkung nur 7 bar Öffnungsdruck.

MTS Chuck

A mere 7 bar of opening pressure results in 12,000 N clamping power thanks to internal power boosting.

MTS Spannfutter, automatisierbar

Automatische Reinigung der Auflageflächen und des Zentrierzapfens beim Werkstückwechsel.

MTS chuck, automatable

Automatic cleaning of contact surfaces and of the centering spigot cone while the workpiece is changed.

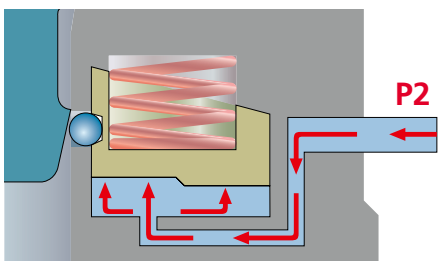

Anschluss (P2)
 Öffnen
Prise (P2)
 Ouverture

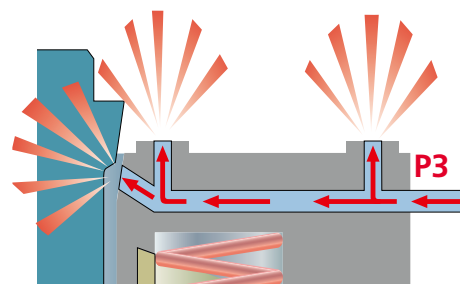

Anschluss (P3)
 Reinigen
Prise (P3)
 Cleaning

MTS IntegralChuck S-P (single + multiple / manually)

ER-033402



- Ausführung** Für den direkten Einbau in Maschinentische, Platten, Spanntürme, Winkel oder Teilapparate.
- Anschlüsse** Zum Öffnen: Pneumatisch.
- Anwendung** Zur Aufnahme von Einzel- oder Mehrfachpaletten.
- Version** For direct integration in machine tables, plates, tombstones, squares or dividing heads.
- Connections** To open: pneumatic or hydraulic.
- Application** To accommodate single or multiple pallets.

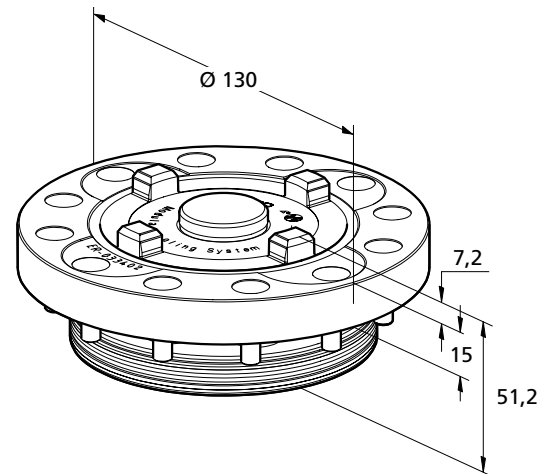

MTS IntegralChuck S-P/A (single + multiple / auto)

ER-036802



- Ausführung** Für den direkten Einbau in Maschinentische, Platten, Spanntürme, Winkel oder Teilapparate.
- Anschlüsse** Zum Öffnen: Pneumatisch.
Zum Reinigen: Pneumatisch.
- Anwendung** Zur Aufnahme von Einzel- oder Mehrfachpaletten.
- Version** For direct integration in machine tables, plates, tombstones, squares or dividing heads.
- Connections** To open: pneumatic.
To clean: pneumatic.
- Application** To accommodate single or multiple pallets.

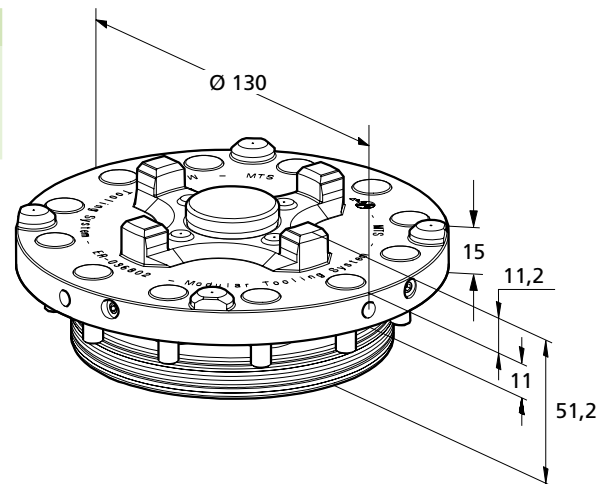

| Spannzapfen / Spigot | | |
|----------------------|--|--|
| ER-033800 | manuell / 0-Punkt Zapfen manually zero point locating | |
| ER-039201 | auto / Ausgleichszapfen auto / alignment spigot | |
| ER-039200 | auto / Zapfen mit Spiel auto / spigot with clearance | |
| ER-038000 | auto / 0-Punkt Zapfen auto / Zero point spigot | |

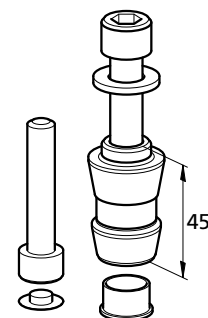

Um Ihnen die schnelle Orientierung über die Anwendungsbereiche der EROWA Produkte zu erleichtern, verwenden wir die folgenden Zeichen:

To make it easier for you to find your way about the fields of application for EROWA products, we use the following symbols:

- S** = Single
M = Multi
A = Automatisierbar / Able to automate
P = Pneumatisch betätigt / Pneumatically operated

- Manuelle Bedienung
Manual operation
- Geeignet zur Anwendung unter Flüssigkeit
Suited for submerged operation
- Geeignet für die automatische Anwendung
Suited for automatic operation
- Für spanabhebende Bearbeitung
For chip-removing processes
- Zum Senkerodieren
For EDM sinking

MTS IntegralChuck M-P (multiple / manually)

ER-033400



- Ausführung** Für den direkten Einbau in Maschinentische, Platten, Spanntürme, Winkel oder Teilapparate.
- Anschlüsse** Zum Öffnen: Pneumatisch.
- Anwendung** Zur Aufnahme von Einzel- oder Mehrfachpaletten.
- Version** For direct integration in machine tables, plates, tombstones, squares or dividing heads.
- Connections** To open: pneumatic or hydraulic.
- Application** To accommodate single or multiple pallets.

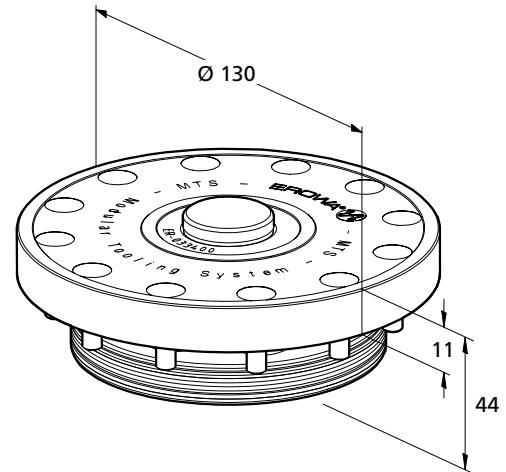

MTS IntegralChuck M-P/A (multiple / auto)

ER-036800



- Ausführung** Für den direkten Einbau in Maschinentische, Platten, Spanntürme, Winkel oder Teilapparate.
- Anschlüsse** Zum Öffnen: Pneumatisch.
Zum Reinigen: Pneumatisch.
- Anwendung** Zur Aufnahme von Einzel- oder Mehrfachpaletten.
- Version** For direct integration in machine tables, plates, tombstones, squares or dividing heads.
- Connections** To open: pneumatic.
To clean: pneumatic.
- Application** To accommodate single or multiple pallets.

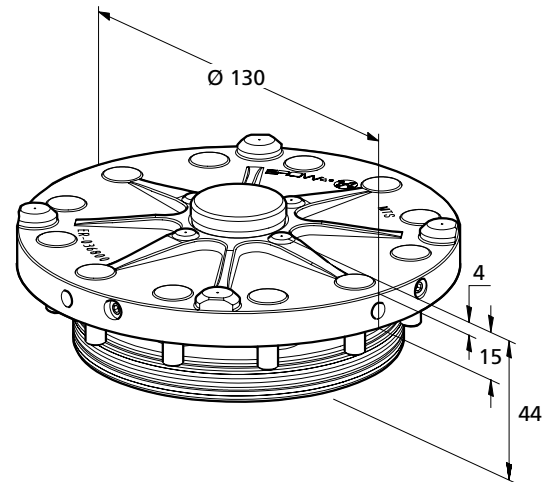

| Spannzapfen / Spigot | | |
|----------------------|--|--|
| ER-033800 | manuell / 0-Punkt Zapfen manually zero point locating | |
| ER-039201 | auto / Ausgleichszapfen auto / alignment spigot | |
| ER-039200 | auto / Zapfen mit Spiel auto / spigot with clearance | |
| ER-038000 | auto / 0-Punkt Zapfen auto / Zero point spigot | |

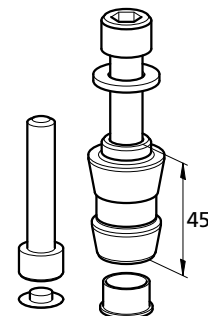

Um Ihnen die schnelle Orientierung über die Anwendungsbereiche der EROWA Produkte zu erleichtern, verwenden wir die folgenden Zeichen:

To make it easier for you to find your way about the fields of application for EROWA products, we use the following symbols:

- S** = Single
M = Multi
A = Automatisierbar / Able to automate
P = Pneumatisch betätigt / Pneumatically operated

- Manuelle Bedienung
Manual operation
- Geeignet zur Anwendung unter Flüssigkeit
Suited for submerged operation
- Geeignet für die automatische Anwendung
Suited for automatic operation
- Für spanabhebende Bearbeitung
For chip-removing processes
- Zum Senkerodieren
For EDM sinking

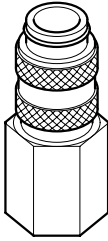
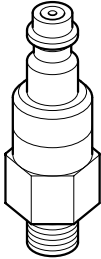
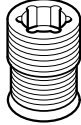
| | | | | | |
|--|--|--|---|--|---|
| OPSKU | G1/4" Innengewinde <i>Internal thread</i> | OPST-NI | G1/8" Aussengewinde <i>Male thread</i> | OPRV | G1/8" Aussengewinde <i>Male thread</i> |
|  <p>Schnellkupplung <i>Quick fitting coupling</i></p> | |  <p>Stecknippel verschmutzungsgeschützt <i>Plug nipple protected against staining</i></p> | |  <p>Rückschlagventil <i>Nonreturn valve</i></p> | |
| OPANS-8 | G1/4" Aussengewinde <i>Male thread</i> | | | | |

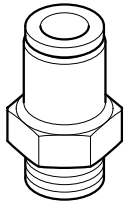

Für 8 mm Schlauch / *For hose*

Abdeckung
Cover

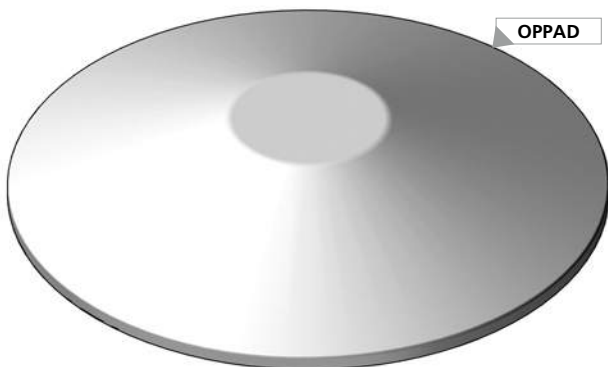

Dichtlippe
Leakproof cover

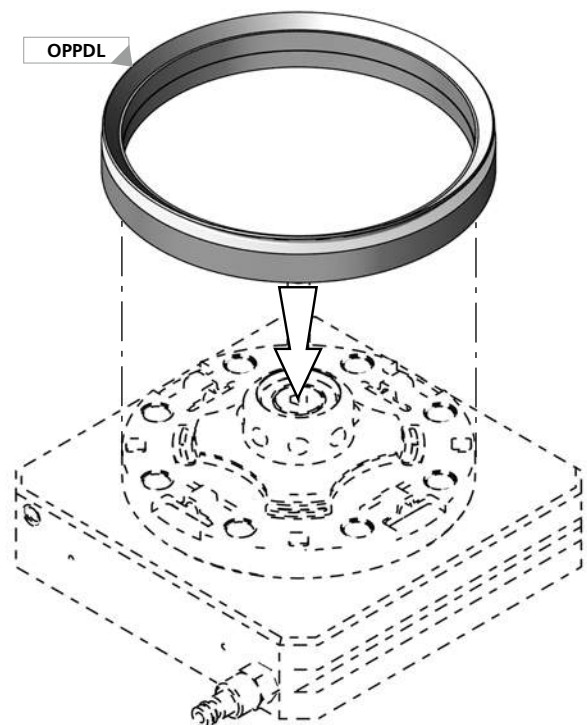

| | |
|--------------|-----------|
| | kg |
| OPPDL | ~0,525 |
| OPPDL | ~0,075 |

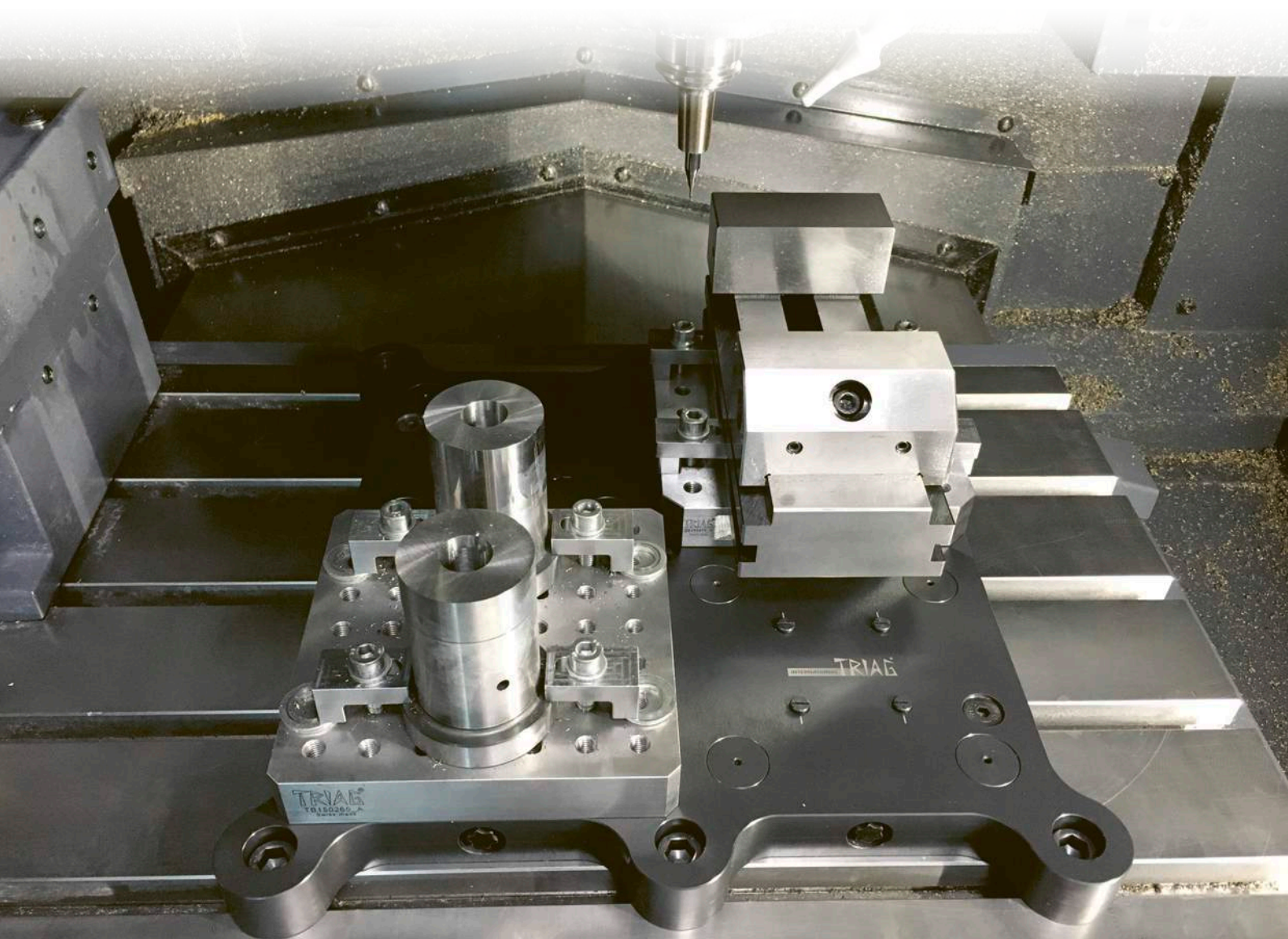

Bestellbeispiel / *Ordering example* : 1x **OPPDL**



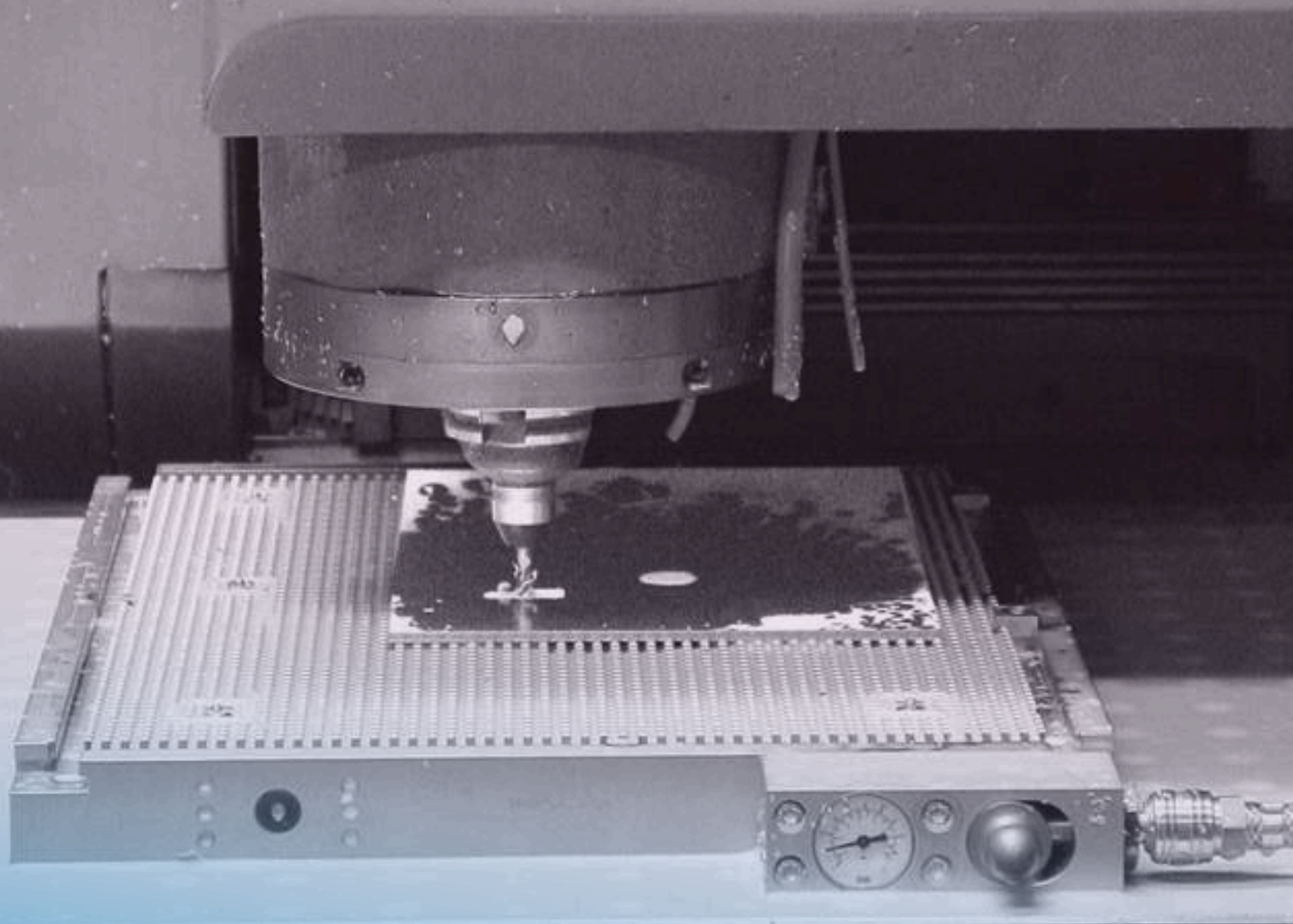

trivaCLAMP



| | | |
|---|---|-----------|
|  | Einleitung <i>Introduction</i> | 305 - 307 |
|  | Bedienungsanleitung <i>Operating manual</i> | 308 - 309 |
| | Anwendungsbeispiele <i>Examples of application</i> | 310 - 312 |
| | Modulare Vakuumplatten <i>Modular vacuum plates</i> | 314 - 317 |
| | Vakuum-Modul für powerCLAMP <i>Vacuum module for powerCLAMP</i> | 318 - 319 |
| | Kombinationsvarianten (Vakuumplatten) <i>Possible combination of vacuum plates</i> | 320 |
| | Startersets nach Ihrer Wahl <i>Starter kit (Your choice)</i> | 321 |
| | Zubehör <i>Accessories</i> | 322 - 324 |
| | Vakuum erzeugen <i>Generate vacuum</i> | 325 - 327 |

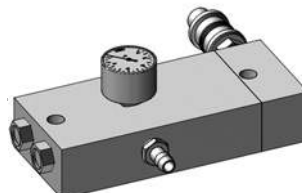
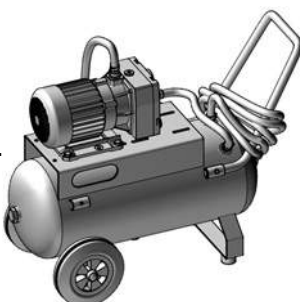
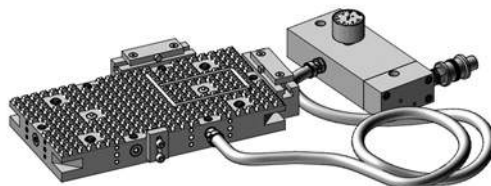
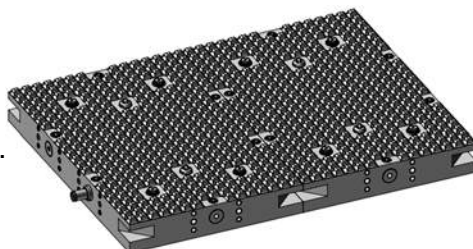
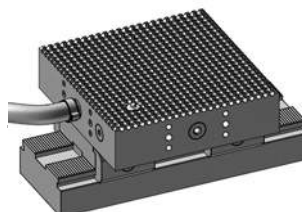
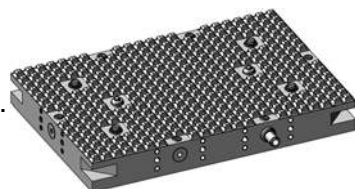

Vakuumpspannen

Die mechanische Spannung hat bekanntlich auch Nachteile. Hohe Kräfte auf das Werkstück können zu Druckmarken und Verformungen führen. Vor allem bei grösseren Werkstücken besteht zudem die Gefahr, dass das Werkstück vibriert.

Workholding by vacuum

Mechanical clamping, as described before, has disadvantages. High specific forces on the workpiece can cause pressure marks and distortions. And, particularly on large parts, there is a risk that the workpiece will vibrate.

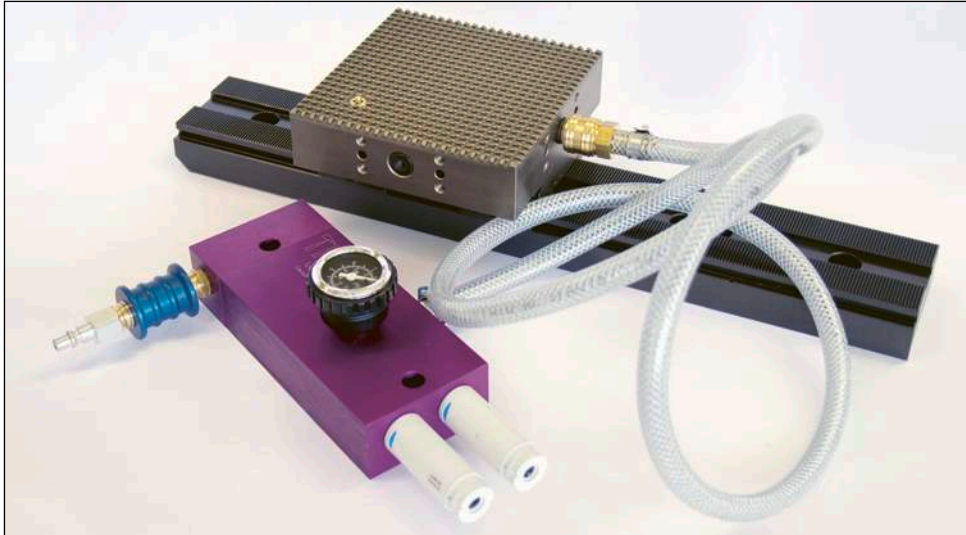

Bei der Spannung mit Vakuum wird der Druck nicht mechanisch auf das Werkstück sondern durch die umgebende Atmosphäre ausgeübt. Dadurch werden die Werkstücke schonend und gleichmässig über die ganze Auflagefläche fixiert, so dass kaum Vibrationen entstehen. Der Beschickungs- und Arbeitsraum bleibt zudem frei von Briden und Spannmittel.

In vacuum clamping the clamping force is not applied to the work piece mechanically, but is provided by the surrounding atmosphere. This means that the work piece is gently and evenly pulled down over the whole supporting surface, so that vibration is minimized. As there are no obstructing brackets, clamps or workholding modules in the working and loading area, there are fewer chances for collisions with the tool.

► **Diese Spannmethode ist vor allem für grossflächige, dünnwandige, auch nichtmagnetische Werkstücke geeignet.**

► **This clamping method is particularly suitable for large surface, thin-walled and also non magnetic work pieces.**

Triva Clamp besteht aus folgenden Funktionsteilen:

Triva Clamp consists of the following functional devices:

- **Vakuumpplatten** mit passenden Anschlagleisten für den Einsatz mit seitlich einwirkenden Kräften.
- **Dichtschnur aus Silikongummi**, die immer entlang der Peripherie des Werkstückes eingelegt wird. Die Haltekraft wächst proportional zur Aufspannfläche, die durch die Dichtschnur begrenzt wird.
- **Rotations-Vakuumpumpe** mit Schaltventil und Druckwächter optional.
- **Injektorpumpe** mit Schaltventil.

- **Vacuum plates** with suitable stop gauges for application with lateral workholding forces.
- **Silicone-rubber sealing cord** inlaid along the periphery of the work piece. The clamping force increases proportionally to the surface area defined by the sealing cord.
- **Rotary vacuum pump** with control unit and pressure sensor.
- **Injector pump** with control unit.

Die Ansaugbohrungen werden mit Hilfe von **Triva Clamp-Ventilen** versiegelt. Wenn die Ventile geschlossen sind, sind keine Löcher in der Platte vorhanden, so dass kaum Kühlflüssigkeit eindringen kann. Das **Triva Clamp-Ventil** wird bei der Auflage des Werkstückes automatisch aktiviert. Ständiges manuelles Öffnen und Verschliessen der Bohrungen entfällt somit.

*The suction holes are sealed by the **Triva Clamp valves**. With these valves closed there are no holes in the plate so that hardly any coolant can enter. The **Triva Clamp valve** is automatically activated by placing the work piece on the vacuum plate. Hence constant opening and closing of the suction holes is omitted.*

Theoretische Haltekraft:

Unter Einbezug eines Sicherheitsfaktors für atmosphärische Druckschwankungen und Leckagen im Vakuumkreislauf rechnen wir mit einem zur Verfügung stehenden Druck von 0,85 bar Vakuum oder 8,5 N/cm² (wobei der Druck von der Höhe über Meer abhängig ist).

Diesen Druck bezeichnen wir als theoretisch 100%. Bei 300 cm² Spannfläche ergibt sich also eine theoretische Spann-/Haltekraft von 8,5 N/cm² x 300 cm² = 2550N.

Diese theoretische Haltekraft basiert auf einem vollständigen Hohlraum unter dem Werkstück. Dies ist in der Praxis jedoch nicht möglich, weil das Werkstück abgestützt werden muss.

Effektive Haltekraft:

Das heisst, je grösser der Hohlraum unter dem Werkstück und je geringer die Auflagefläche für das Werkstück, desto grösser sind die Haltekräfte.

Die effektive Haltekraft ist folglich abhängig vom Wirkungsgrad des Vakuumspannsystems.

Vakuumspannsysteme im Vergleich:

Lochplatte Plate with suction holes

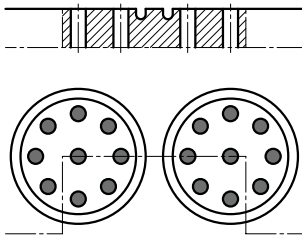

Pro Element Ø 40 mm
9 Bohrungen Ø 4 mm.
Each section of Ø 40 mm
having 9 bores of Ø 4 mm.

Wirkungsgrad: 9%
Degree of efficiency: 9%

Schlitzplatte Plate with slots

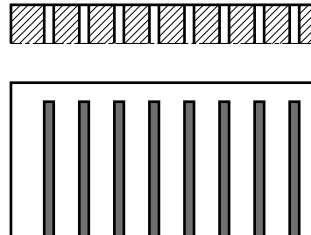

Steg 8 mm, Schlitz 2 mm
Slots 2 mm, bar 8 mm

Wirkungsgrad: 25%
Degree of efficiency: 25%

Theoretical holding force:

Including a safety factor for atmospheric pressure variations and leaks within the vacuum circuit, we calculate an available pressure of 0,85 bar (12,1psi) vacuum equalling 8,5 N/cm² (whereas pressure is dependent on altitude).

This amount of pressure is referred to as theoretically attainable 100%. For 300 cm² /46,5 sq inch the pressure thus is 8,5 N/cm² x 300 cm² = 2550N (12,1psi x 46,5sq in = 562lbs).

This theoretically calculated holding force is based upon a hollow space underneath the entire work piece. This is not possible because the work piece must be supported. Therefore we have to subtract the area supporting the workpiece.

Effective holding force:

In other words: the larger the work piece supporting area, thus reducing the hollow space representing the holding area, the lesser the holding force.

Consequently, the effective holding force depends entirely upon the rate of efficiency of the vacuum system.

Comparison of various vacuum systems:

Nutenplatte Plate with U-shaped grooves

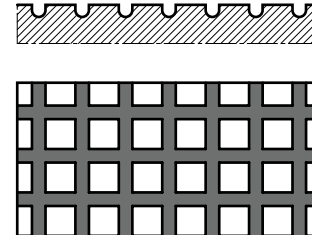

Raster 10x10 mm, Nute 3 mm
Grid 10x10 mm, grooves 3 mm

Wirkungsgrad: 51%
Degree of efficiency: 51%

Triva Clamp Waffelmuster Triva Clamp waffle pattern

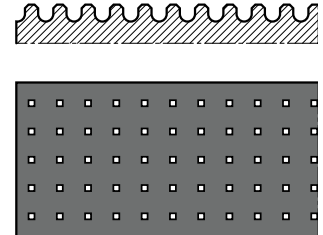

Raster 6,5 mm, Nute 5 mm
Grid 6,5 mm, grooves 5 mm

Wirkungsgrad: 92%
Degree of efficiency: 92%

Besonderheiten von Triva Clamp:

Durch die besondere Formgebung der Werkstückauflage (Waffelmuster) erreicht Triva Clamp einen kaum zu übertreffenden **Wirkungsgrad von theoretisch 92% = 2346 N bei einem maximal erreichbaren Wert von 2550 N (bezogen auf 300 cm² Spannfläche).**

Toleranzen

Höhe 40 mm ± 0,02 / 400 mm
Ebenheit über alles: ± 0,03 / 400 mm

Special features Triva Clamp:

The unique shape of the Triva Clamp workpiece supporting area (waffle pattern) guarantees maximum attainable holding force with a rate of **efficiency of theoretically 92%, equalling 2346 N holding force applied to the work piece of 300cm² (46,5sq in) holding surface.**

Tolerances

Height 40 mm ± 0,02 / 400 mm
Flatness all over: ± 0,03 / 400 mm

Alle Vakuumplatten sind aus hochfestem Aluminium hergestellt und für eine lange Lebensdauer **Hartanodisiert** beschichtet. Durch an jeder Seite angebrachte Koppelbohrungen wird es möglich, die Spannfläche nach Bedarf allseitig zu erweitern.

Vacuum plates are made from high tensile aluminum alloy, are **hard anodized** treated for long tool life. Triva plates can be coupled longitudinally and transversely with any holding plate to suit workpieces, limited by machine table size only.

Mechanische Spannung = Druck auf das Werkstück, daraus resultieren:

- Belastung des Werkstücks
- Druckmarken in weichen Werkstoffen
- Verformung labiler Teile
- Risiko von Vibrationen

Mechanical clamping = pressure applied to workpiece, result:

- Stress applied to workpiece
- Pressure marks in soft materials
- Deforming of delicate workpieces
- Risk of vibrations

Vakuumspegnung = Druck auf Spannplatte

Durch die umgebende Atmosphäre, daraus folgt:

- Schonende, gleichmässige Fixierung jeglicher Werkstoffe über die ganze Auflagefläche
- Keine Vibrationen
- Freier Bestückungs- und freier Arbeitsraum

Vacuum clamping = pressure upon vacuum-plate

By the surrounding atmosphere, resulting in:

- Equal distribution of holding force over the Entire workpiece holding surface
- Machining with no risk of vibrations
- Free, clear loading and processing area

Spannen von Platten mit Klemm-Briden

Haltekräft nur am Rand. Vibrationen in Werkstückmitte. Folgeoperationen notwendig.

Clamping of plates, using clamps

Edges fixed only - Vibrations in center of workpiece - Subsequent operations required.

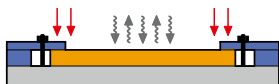

Spannen von unförmigen Werkstücken

Für Werkstücke mit unförmigen Konturen und Durchgangsbohrungen stellen wir Spezialvorrichtungen her.

Holding of bulky workpieces

We build special devices for workpieces with bulky outlines and through bore-holes.

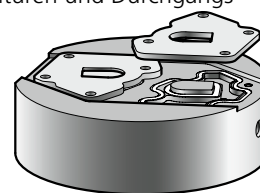

Spannen von Platten mit Tiefspannbacken

Haltekräft nur am Rand, Vibrationen in Werkstückmitte. Hoher Spanndruck erzeugt Spannung und Verformung.

Clamping of plates, using clamping jaws

Also high pressure applied to workpiece, holding effect at the edges - Risk of deformation and vibrations.



Spannen von Platten auf Vakuum-Platte

Haltekräft gleichmässig über ganze Auflagefläche verteilt. Keine Vibrationen - Freier Arbeitsraum.

Holding of plates, using vacuum-plate

Holding force equally spread all over the workpiece holding area - No vibrations - Free processing area.

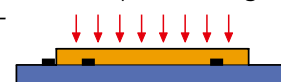

Kubus spannen im Schraubstock

Belastung des Werkstücks - Risiko von Druckmarken.

Clamping of cubic-shaped items, using vise

Stress applied - Risk of pressure marks in workpiece.



Kubisches Werkstück spannen mit Vakuum-Platte und Steilwänden

Werkstück an 3 (bis 5) Seiten ohne mechanischen Druck gehalten.

Holding of cubic-shaped item, using vacuum-plate and vertical walls

Workpiece held from 3 (up to 5) directions. No stress applied - No stress applied - No pressure marks.

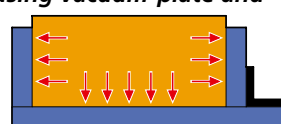

Spannen von U-Profilen im Schraubstock

Risiko von Deformationen und Vibrationen.

Clamping of U-profile, using vise

Risk of deformation and vibrations during processing.

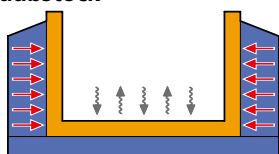

Spannen von U-Profilen mit Vakuum-Platte und Steilwänden

Allseitig gleichmässige, druckfreie Aufspannung. Bearbeitung ohne Risiko von Vibrationen.

Holding of U-profile, using vacuum-plate and 2 vertical walls

Uniform, stressfree holding from 3 directions - No risk of deformations or vibrations during processing.

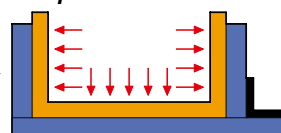

Spannen von Winkelprofil mit Briden

Umständliches Bestücken und Bearbeiten sowie grosse Vibrationen.

Clamping of angled workpiece, using clamps

Bothersome clamps, vibrations, subsequent operation.

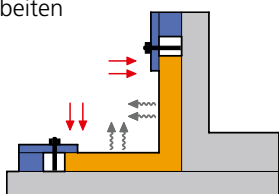

Spannen von Winkelprofil mit Vakuum-Platte und 1 Steilwand

Gleichmässig verteilte Haltekräft. Leichtes Bestücken und freier Arbeitsraum. Keine Vibrationen, keine Nacharbeit notwendig.

Holding of angled workpiece, using vacuum-plate and 1 vertical wall

Uniform stressfree holding - No risk of vibrations - No clamps, free, clear work area for easier, faster loading and processing.

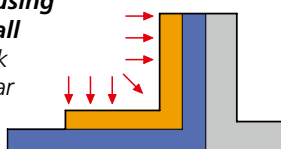

Rote Pfeile → zeigen die Spannrichtung, graue Pfeile ~→ zeigen Vibrationskräfte
Red arrows → show the holding force direction, gray arrows ~→ show vibration forces

Vakuumplatte auf Maschinentisch befestigen / Mounting vacuum plate on machine table

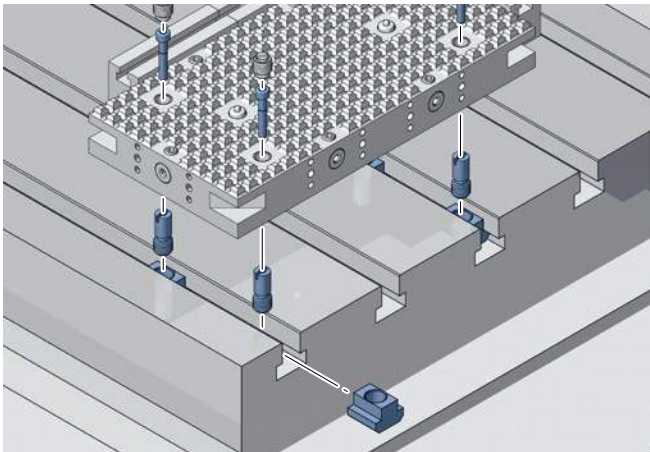

Mechanisch befestigt / Mechanical mounting

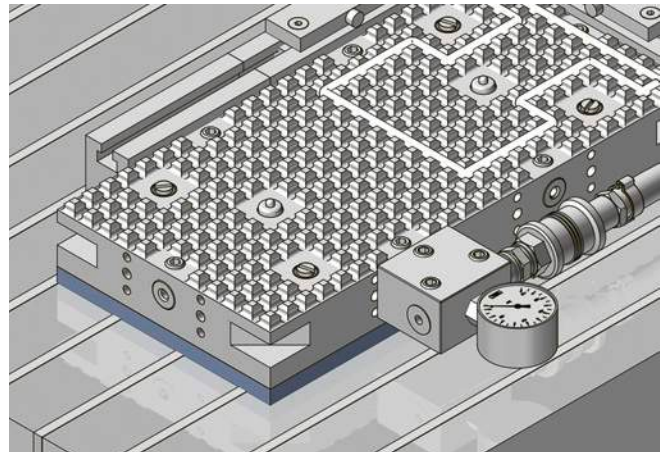

Magnetisch befestigt / Magnetical mounting

Platten koppeln / Connect plates

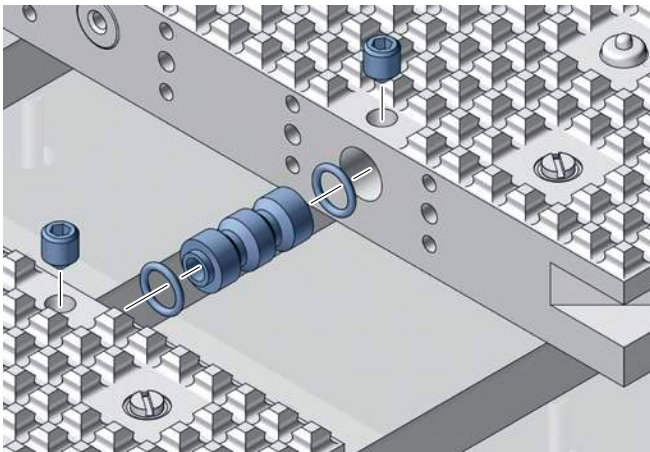

Mit Vakuumverbinder / With vacuum circuit connector

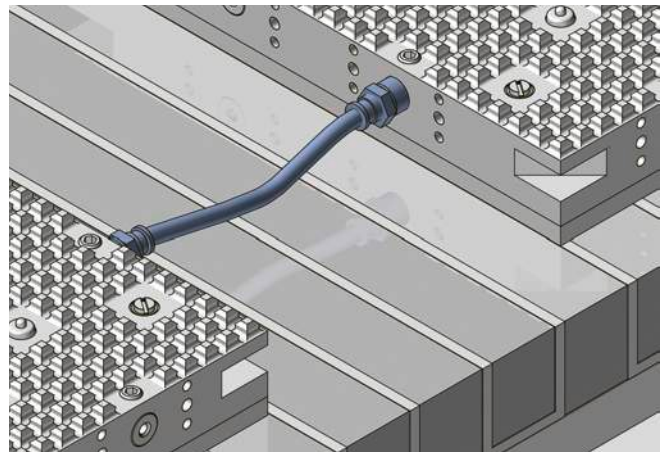

Mit Verbindungsschlauch / With connector-tube

Mit Pumpe verbinden / Connect to pump

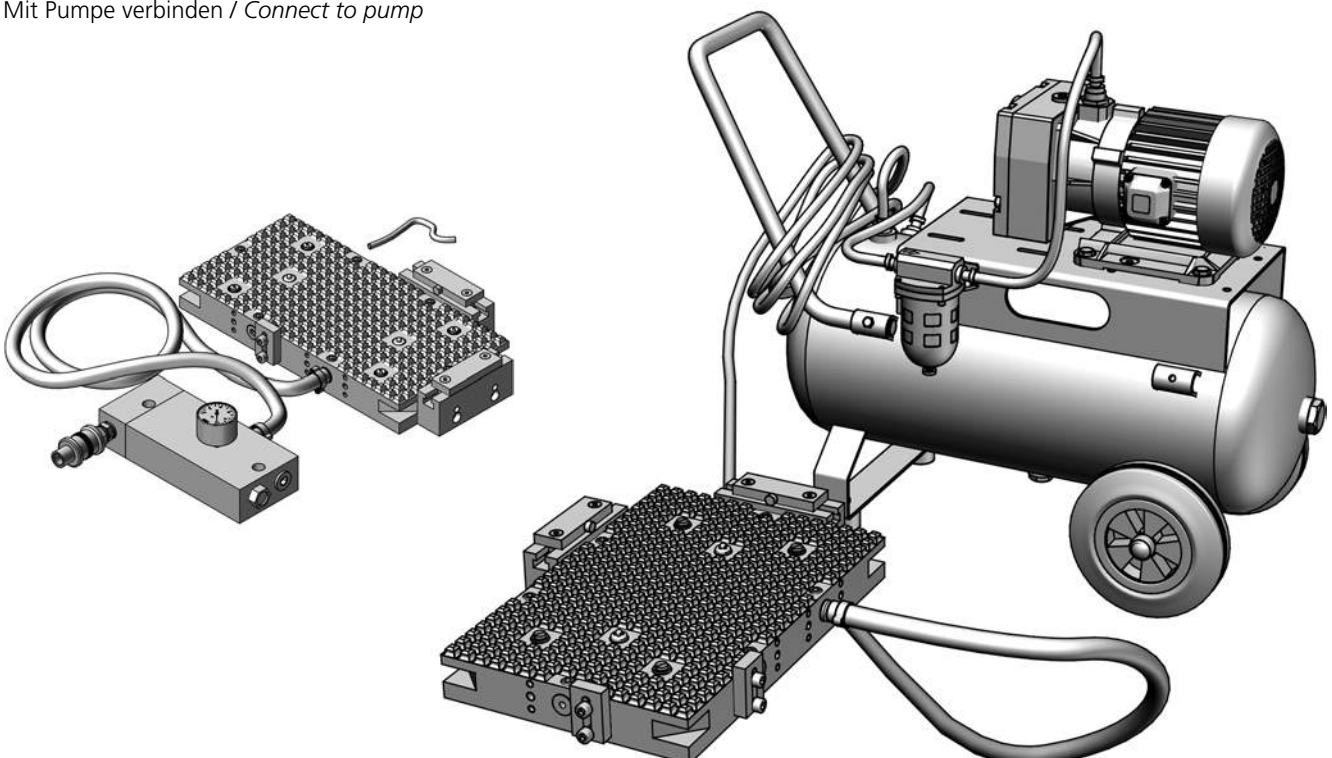

Dichtsnur und Werkstück einlegen / Insert sealing cord and workpiece

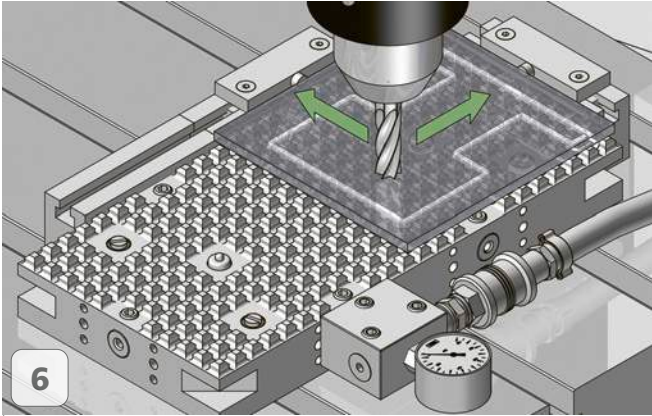
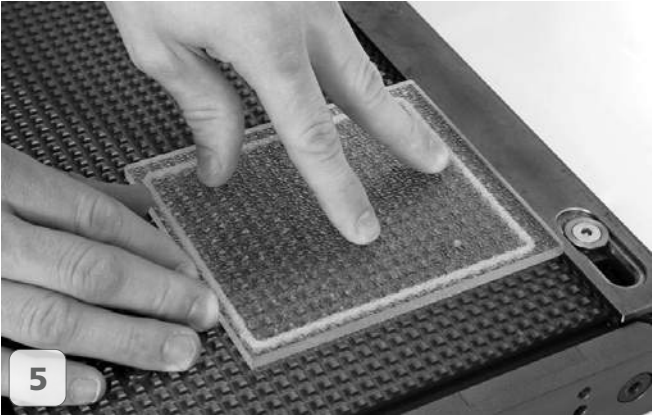
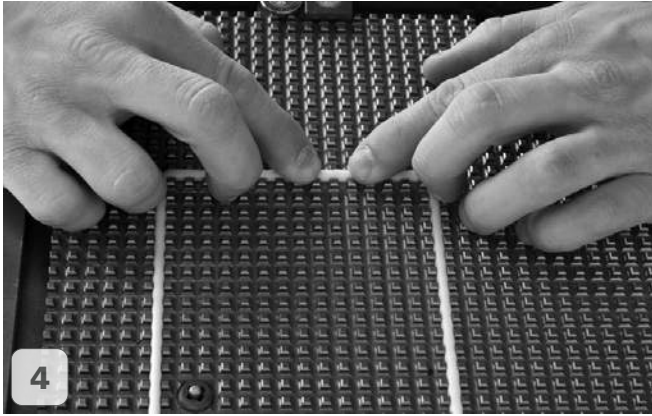
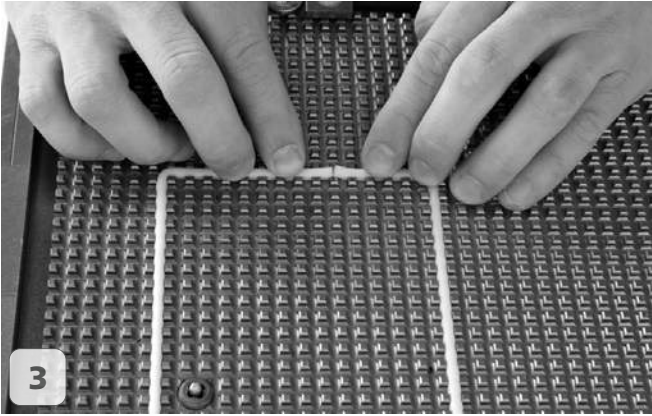
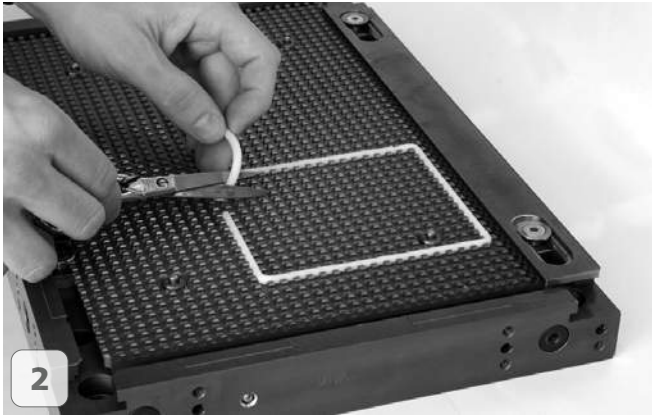
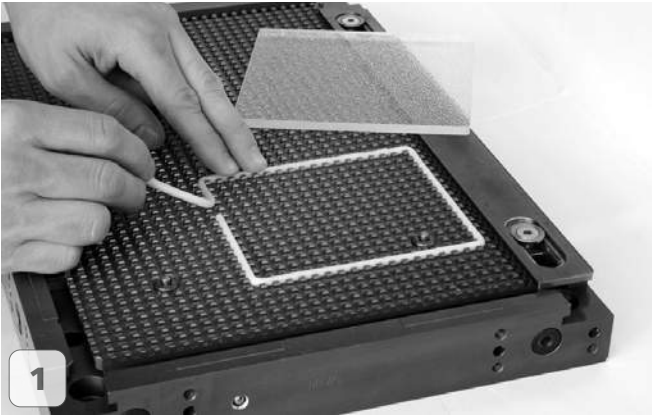

Fräsrichtung beachten:
 wenn möglich, gegen Festanschläge fräsen.
Pay attention to machining direction:
 if possible, toward stop gages milling.

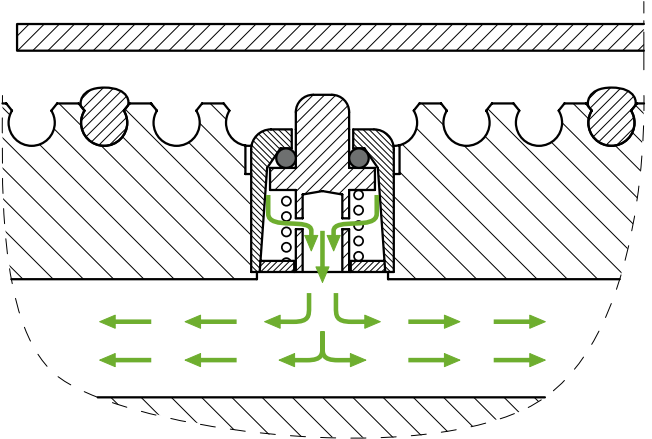

Ventil geschlossen / Valve sealed

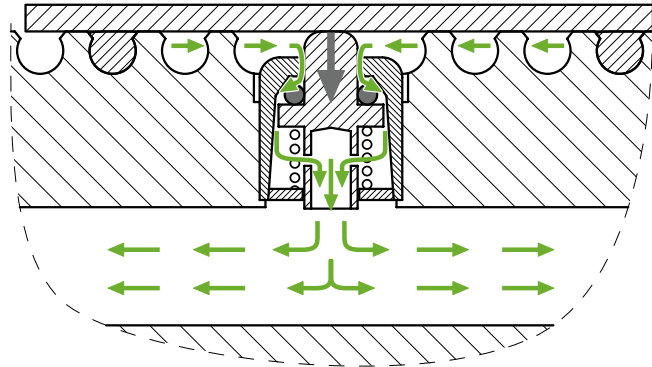

Werkstück eingelegt: Ventil offen
 Workpiece inserted: Valve open



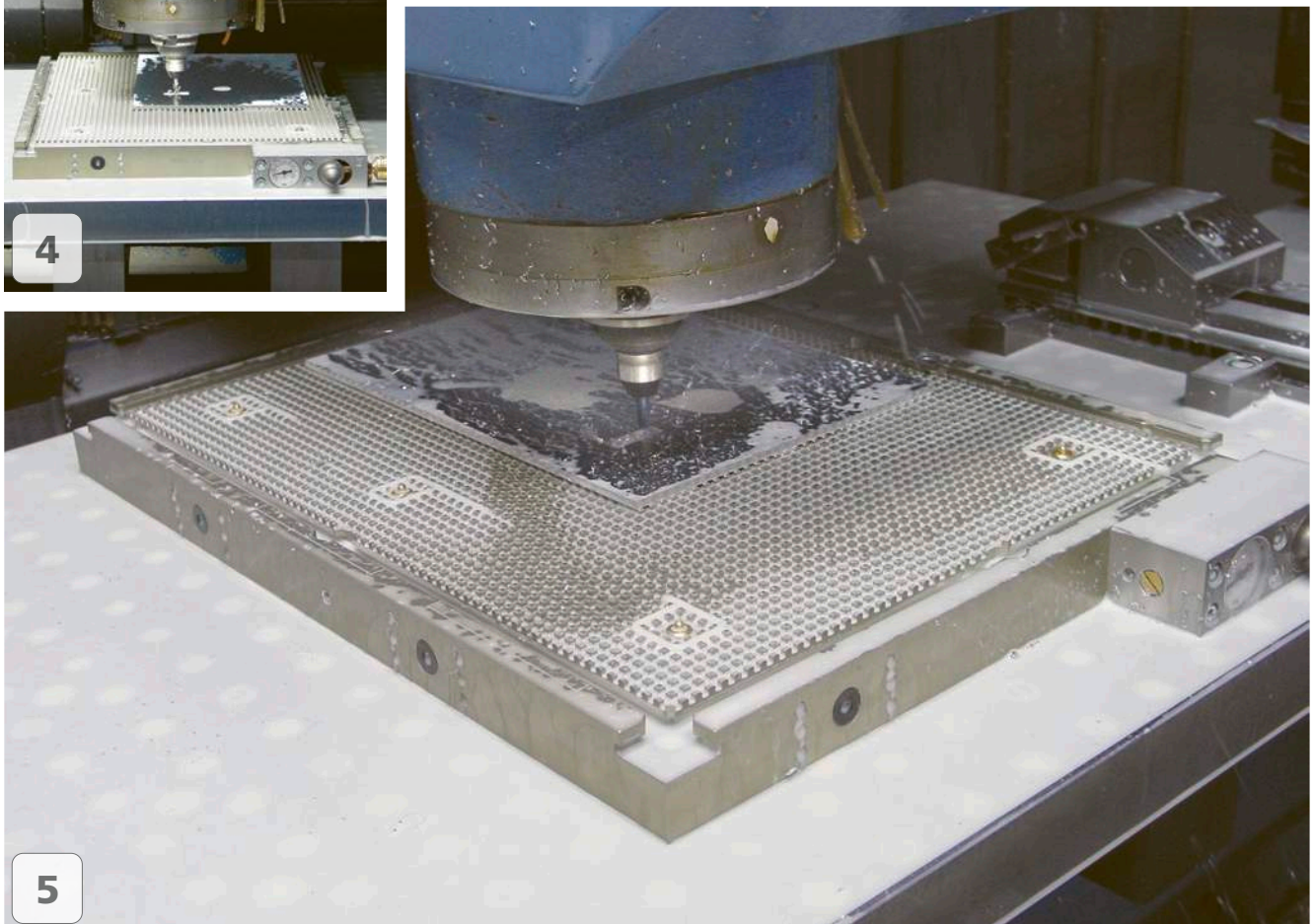
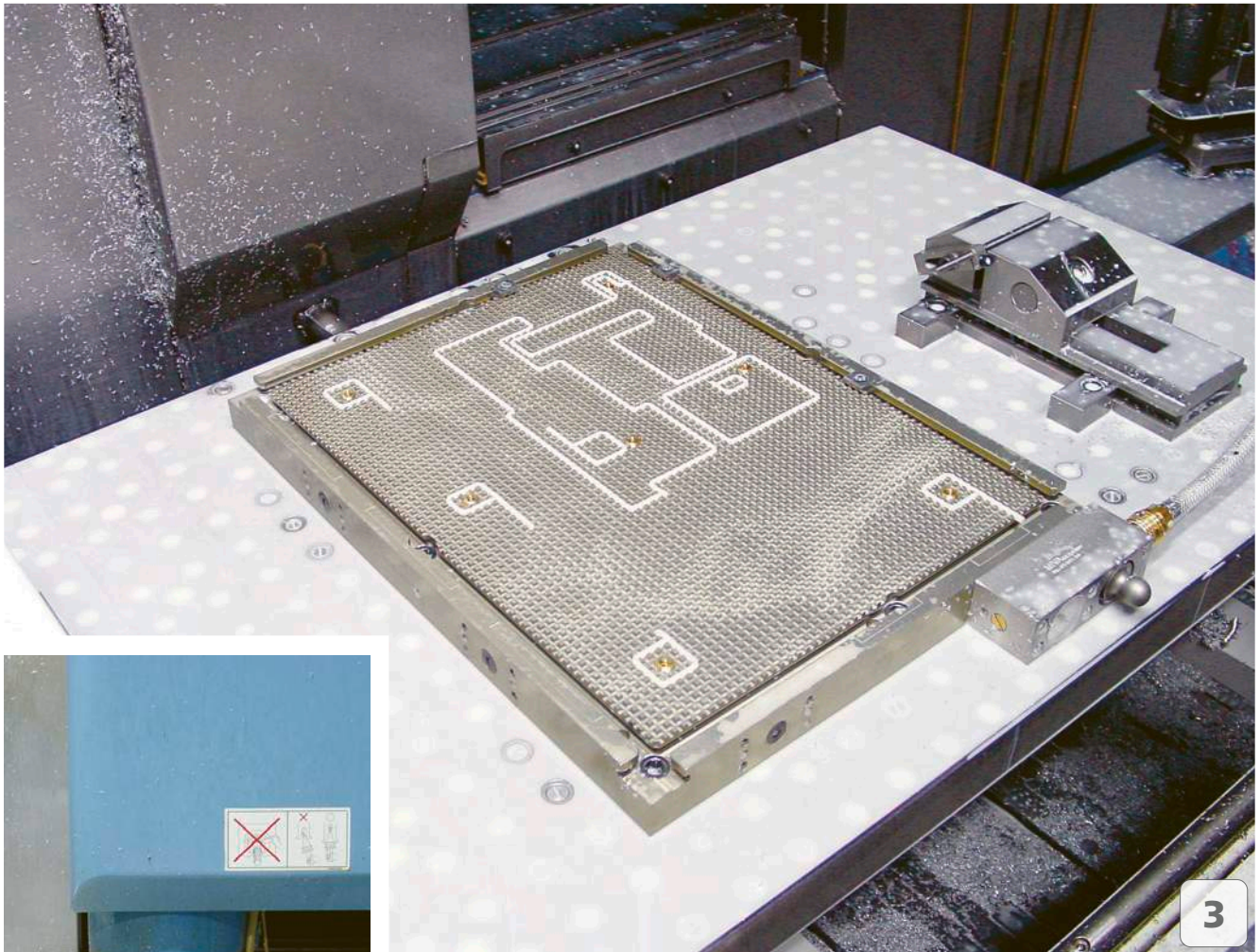

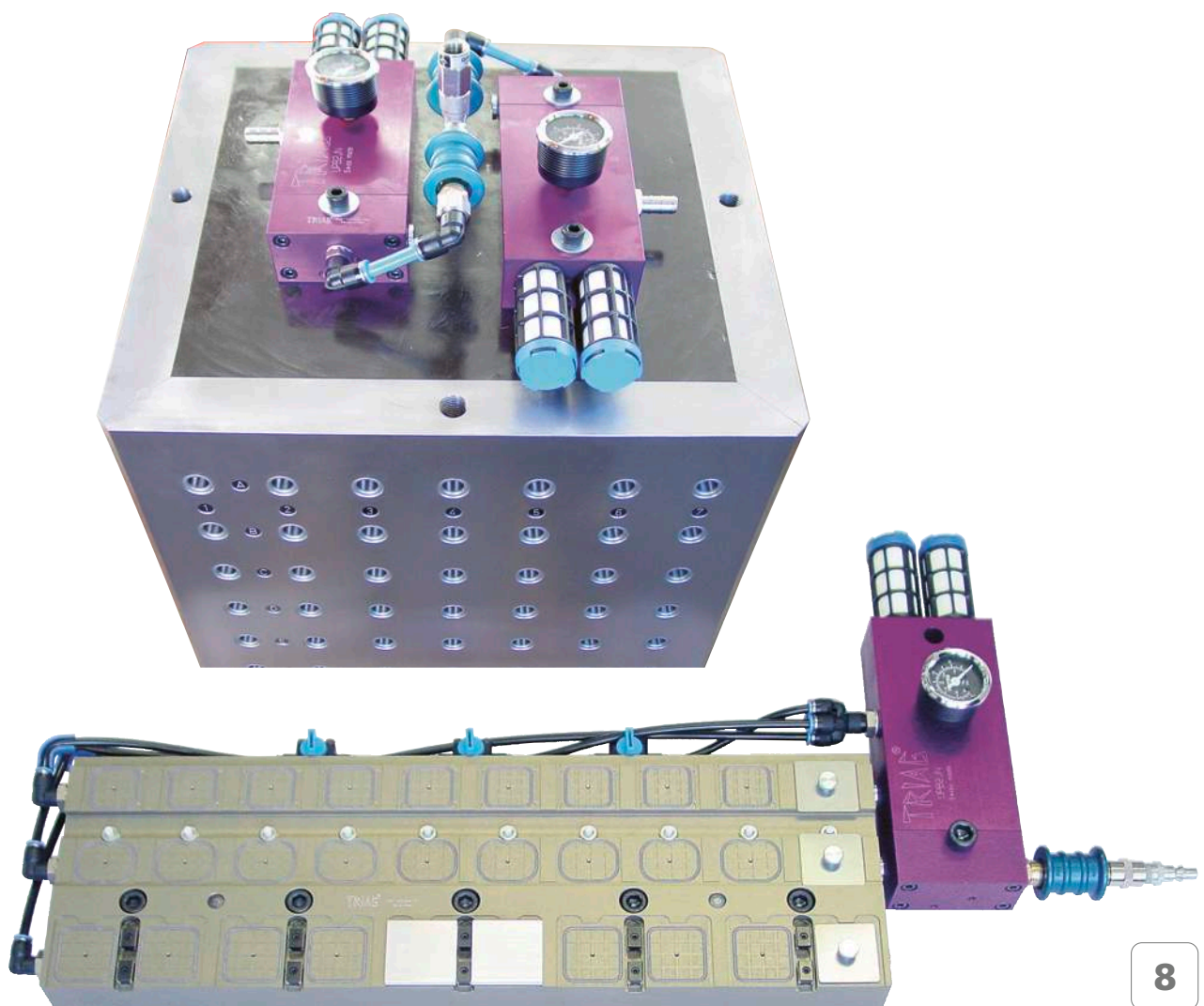

Bestellschlüssel Vakuumplatten

Order code vacuum plates

trivaCLAMP

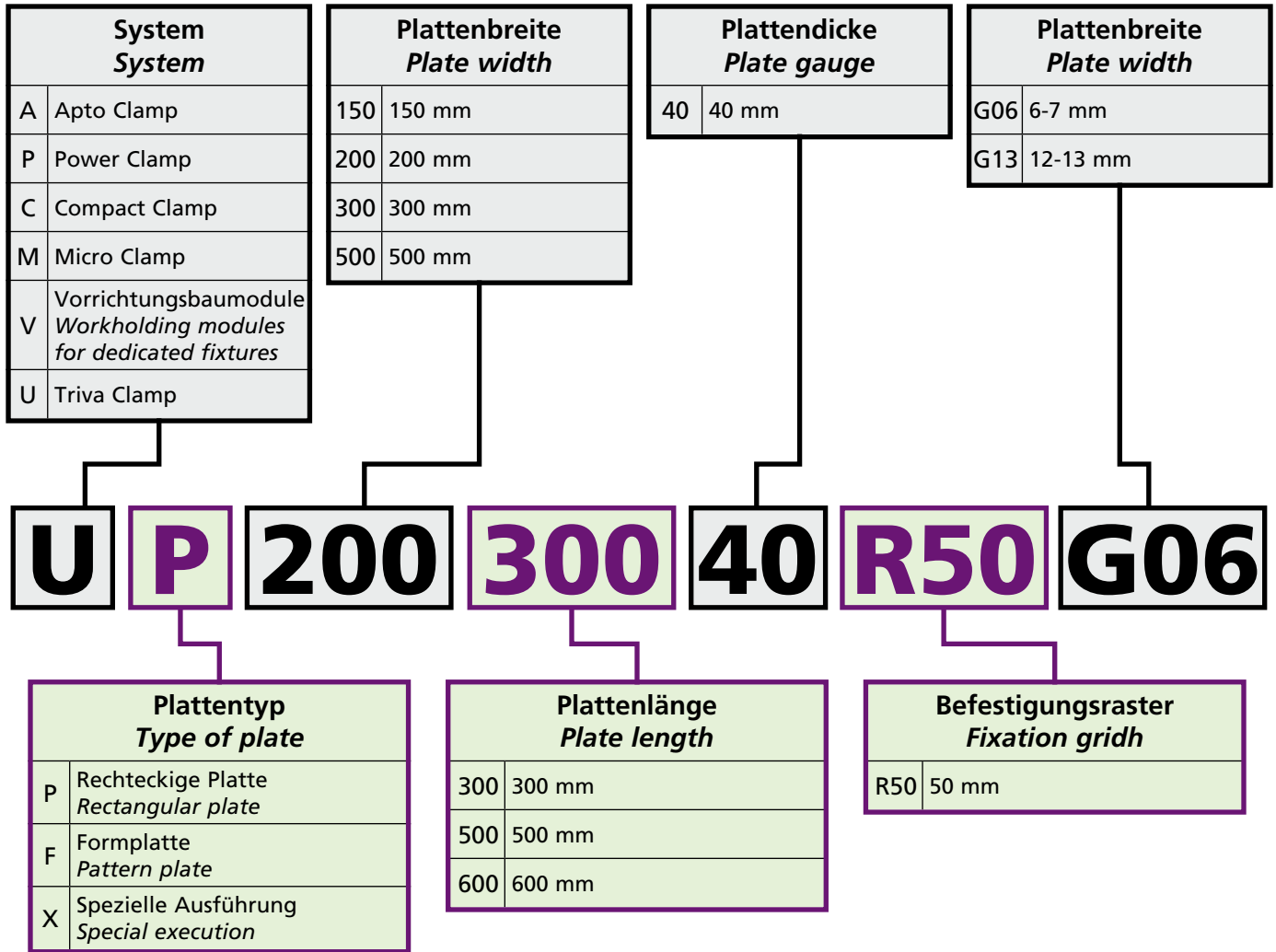

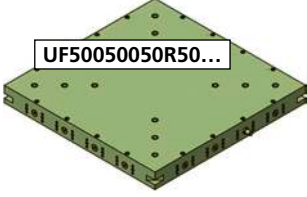

UF50050050R50...

Formplatten
Für spezielle Werkstücke, die für das Spannen auf den Standardplatten ungeeignet sind, haben wir Rohplatten entwickelt, die bis zu 3 mal überfräst werden können. So lassen sich bis zu 3 verschiedene Werkstücke nacheinander bearbeiten.

Die plates
For special work pieces that are unsuitable for clamping on the standard plates, we have developed raw plates that can be milled again up to 3 times. This way, up to 3 different work pieces can be machined one after the other.

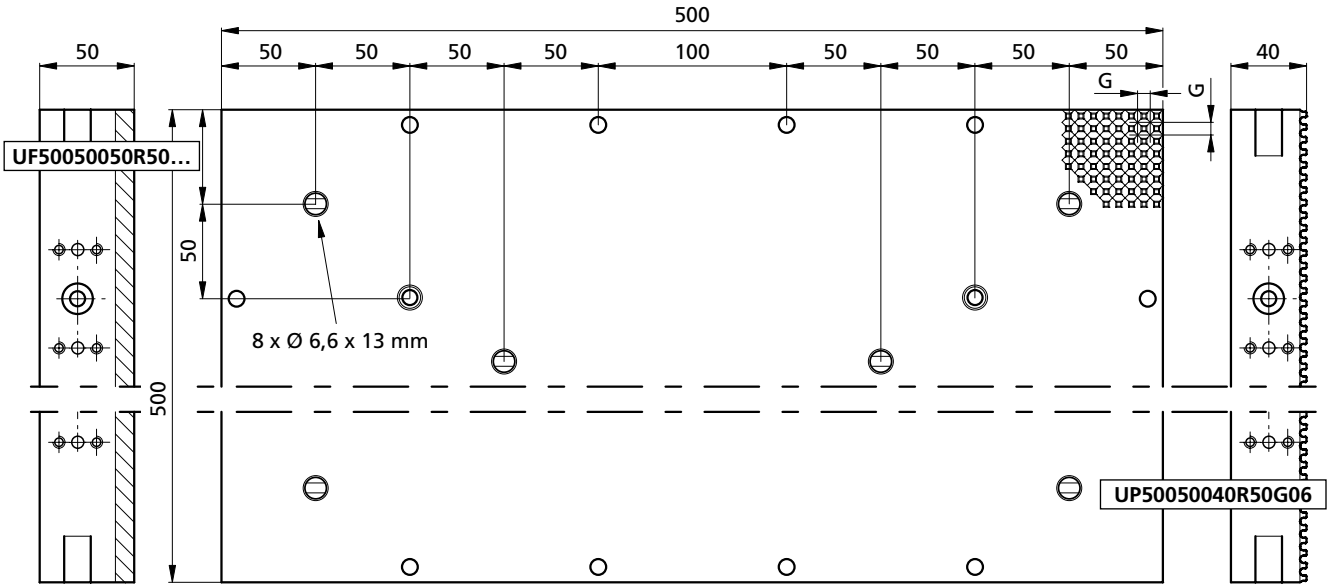

G13

UP50050040R50G13

- 1x TH160150
- 4x 0700100
- 1x 1110100
- 15x 0920000
- 16x 1111003
- 16x M10X12ISO4027
- 8x M6X45ISO4762
- 1x 0910001
- 8x 0700102

G = 12,5 mm

kg ~24

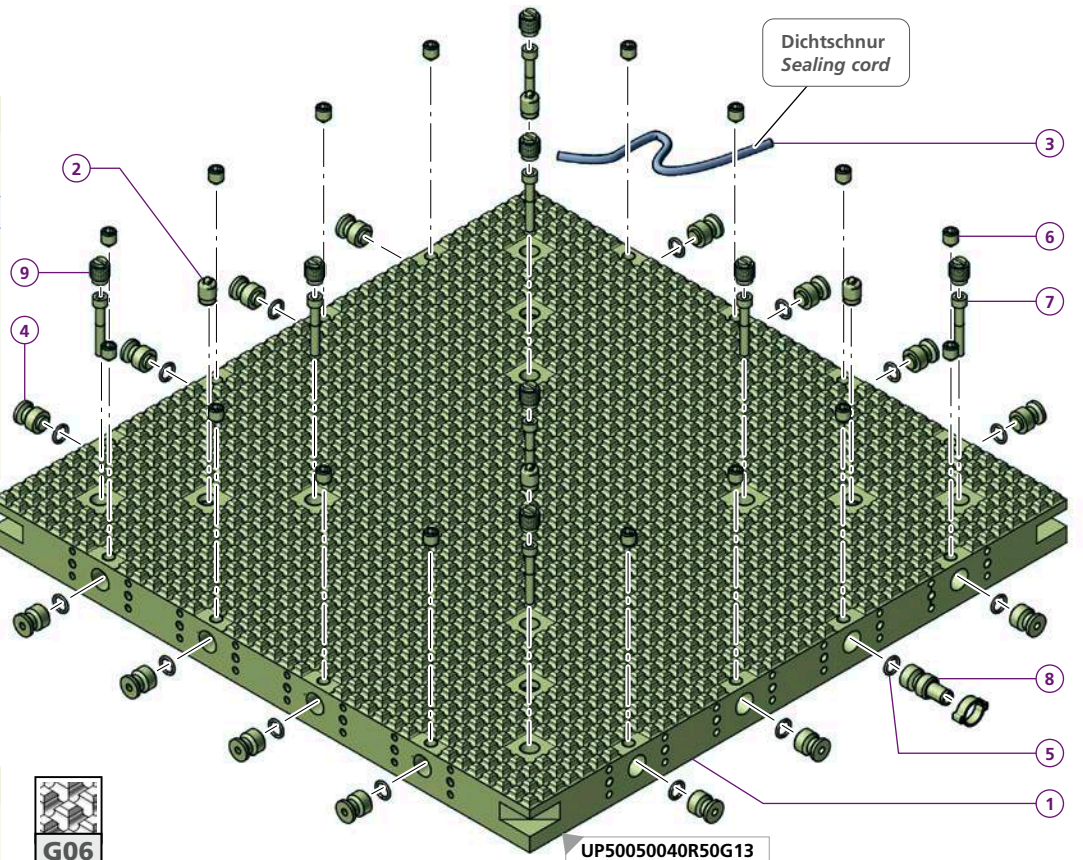

UF50050050R50...

- 1x TH160151
- 4x 0700100
- 1x
- 15x 0920000
- 16x 1111003
- 16x M10X12ISO4027
- 8x M6X45ISO4762
- 1x 0910001
- 8x 0700102

kg ~32,5

G06

UP50050040R50G06

- 1x TB160159
- 1x 1120100

G = 6,5 mm

kg ~26

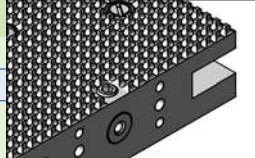

Profilfräser / Carbide end mills G13 / G06 p. 324
Dichtschnüre je nach Bedarf / Sealing cords as needed

Bestellbeispiel / Ordering example:
UP50050040R50G13 & 1x 1110100

Separat bestellen / Order separately

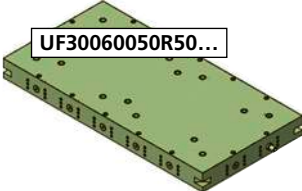

UF30060050R50...

Formplatten
 Für spezielle Werkstücke, die für das Spannen auf den Standardplatten ungeeignet sind, haben wir Rohplatten entwickelt, die bis zu 3 mal überfräst werden können. So lassen sich bis zu 3 verschiedene Werkstücke nacheinander bearbeiten.

Die plates
 For special work pieces that are unsuitable for clamping on the standard plates, we have developed raw plates that can be milled again up to 3 times. This way, up to 3 different work pieces can be machined one after the other.

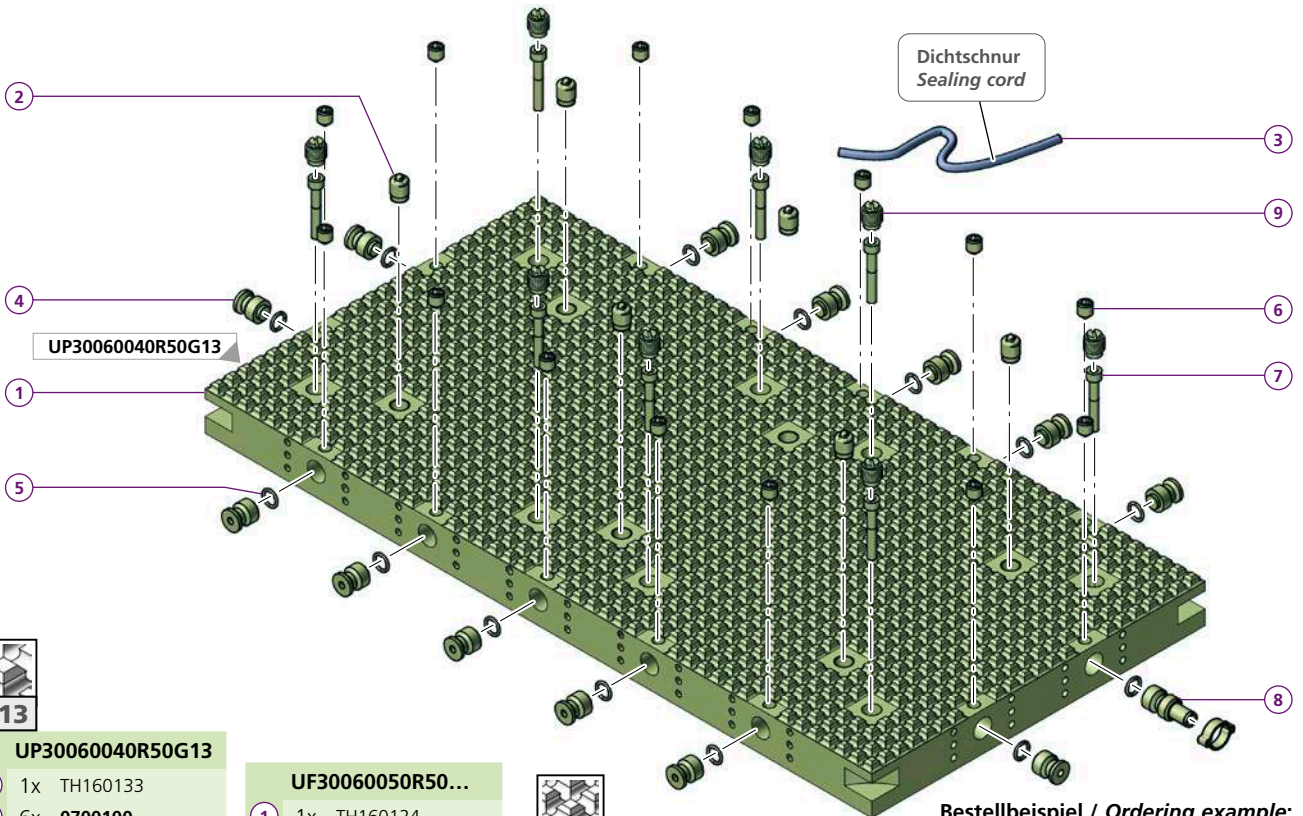
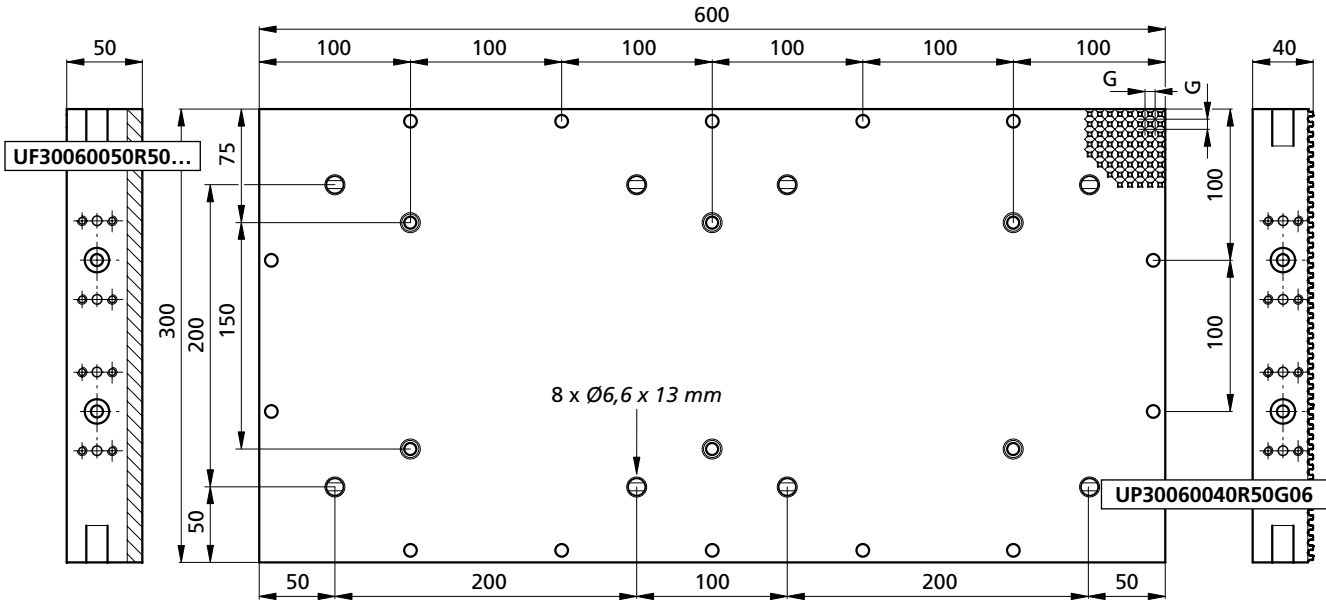

UP30060040R50G13

| | | |
|----|-----|---------------|
| 1 | 1x | TH160133 |
| 2 | 6x | 0700100 |
| 3 | 1x | 1110100 |
| 4 | 13x | 0920000 |
| 5 | 13x | 1111003 |
| 6 | 14x | M10X12ISO4027 |
| 7 | 8x | M6X45ISO4762 |
| 8 | 1x | 0910001 |
| 9 | 8x | 0700102 |
| G | = | 12,5 mm |
| kg | = | ~18 |

UF30060050R50...

| | | |
|----|-----|---------------|
| 1 | 1x | TH160124 |
| 2 | 6x | 0700100 |
| 3 | 1x | |
| 4 | 13x | 0920000 |
| 5 | 13x | 1111003 |
| 6 | 14x | M10X12ISO4027 |
| 7 | 8x | M6X45ISO4762 |
| 8 | 1x | 0910001 |
| 9 | 8x | 0700102 |
| kg | = | ~24,36 |



UP30060040R50G06

| | | |
|----|----|----------|
| 1 | 1x | TH120176 |
| 3 | 1x | 1120100 |
| G | = | 6,5 mm |
| kg | = | ~18,5 |

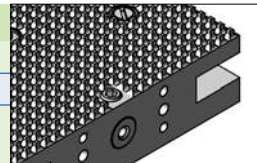

Bestellbeispiel / Ordering example:
UP30060040R50G13 & 1x 1110100

Profilfräser / Carbide end mills G13 / G06 p. 324

Dichtschnüre je nach Bedarf / Sealing cords as needed

Separat bestellen / Order separately

Formplatten
Für spezielle Werkstücke, die für das Spannen auf den Standardplatten ungeeignet sind, haben wir Rohplatten entwickelt, die bis zu 3 mal überfräst werden können. So lassen sich bis zu 3 verschiedene Werkstücke nacheinander bearbeiten.

Die plates
For special work pieces that are unsuitable for clamping on the standard plates, we have developed raw plates that can be milled again up to 3 times. This way, up to 3 different work pieces can be machined one after the other.

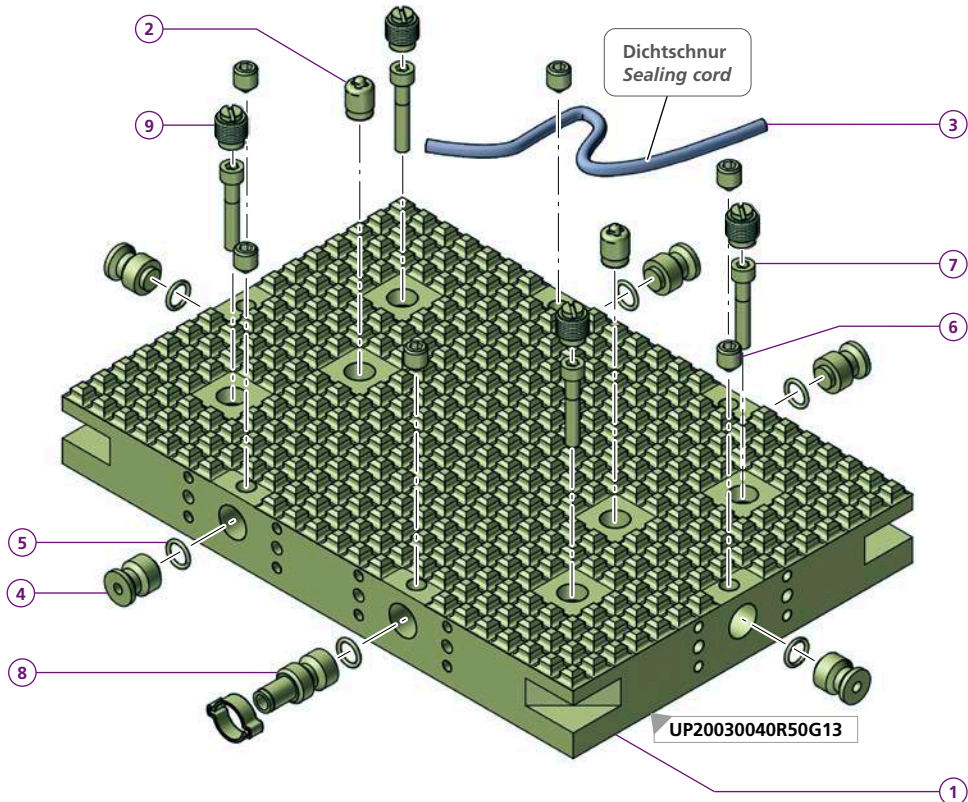
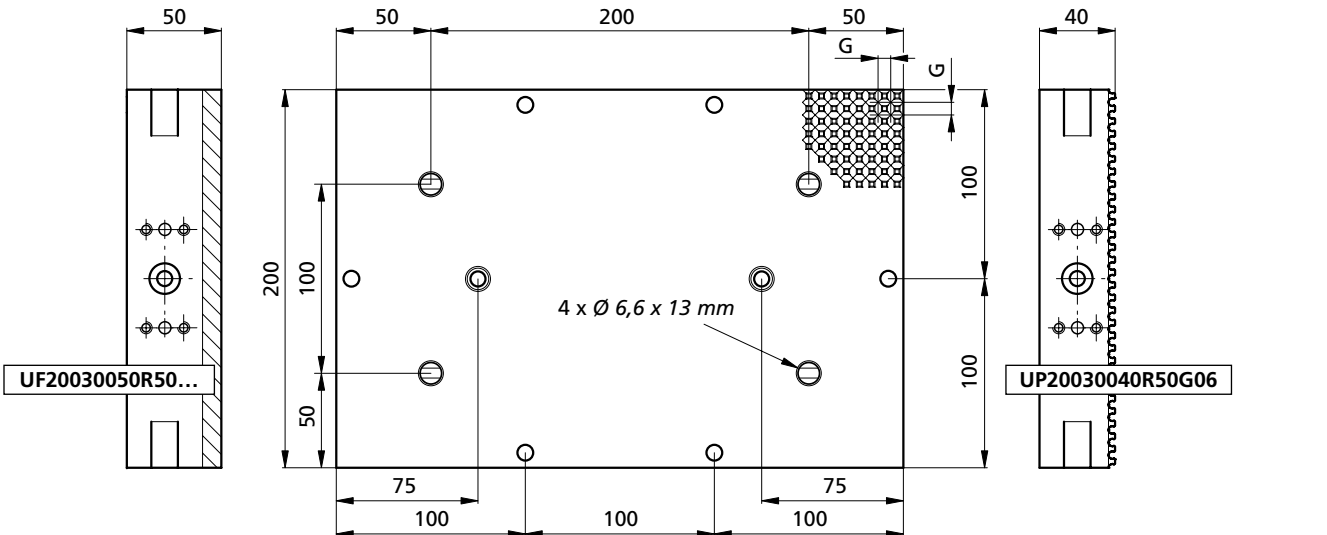

UP20030040R50G13

| | |
|----|------------------|
| 1 | 1x TH160135 |
| 2 | 2x 0700100 |
| 3 | 1x 1110100 |
| 4 | 5x 0920000 |
| 5 | 6x 1111003 |
| 6 | 6x M10X12ISO4027 |
| 7 | 4x M6X45ISO4762 |
| 8 | 1x 0910001 |
| 9 | 4x 0700102 |
| G | = 12,5 mm |
| kg | ~5,5 |



UP20030040R50G06

| | |
|----|-------------|
| 1 | 1x TH120175 |
| 3 | 1x 1120100 |
| G | = 6,5 mm |
| kg | ~6,0 |

UF20030050R50...

| | |
|----|------------------|
| 1 | 1x TH160136 |
| 2 | 2x 0700100 |
| 3 | 1x |
| 4 | 5x 0920000 |
| 5 | 6x 1111003 |
| 6 | 6x M10X12ISO4027 |
| 7 | 4x M6X45ISO4762 |
| 8 | 1x 0910001 |
| 9 | 4x 0700102 |
| kg | ~8,09 |

Bestellbeispiel / Ordering example:
UP20030040R50G13 & 1x 1110100

Profilfräser / Carbide end mills G13 / G06 p. 324

Dichtschnüre je nach Bedarf / Sealing cords as needed

Separat bestellen / Order separately



Formplatten

Für spezielle Werkstücke, die für das Spannen auf den Standardplatten ungeeignet sind, haben wir Rohplatten entwickelt, die bis zu 3 mal überfräst werden können. So lassen sich bis zu 3 verschiedene Werkstücke nacheinander bearbeiten.

Die plates

For special work pieces that are unsuitable for clamping on the standard plates, we have developed raw plates that can be milled again up to 3 times. This way, up to 3 different work pieces can be machined one after the other.

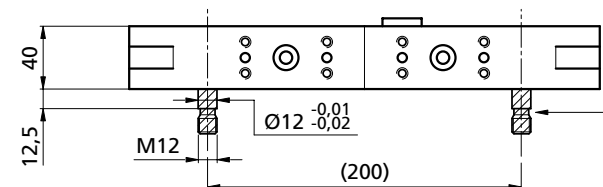

Variante / Variant:
Mechanische Befestigung auf Rasterplatte
Mechanical mounting on locking plate
R50 Ø12 M12



Optionale Stahlplatte für Befestigung auf Magnetunterlage
Optional steel plate for fastening on magnetic basis

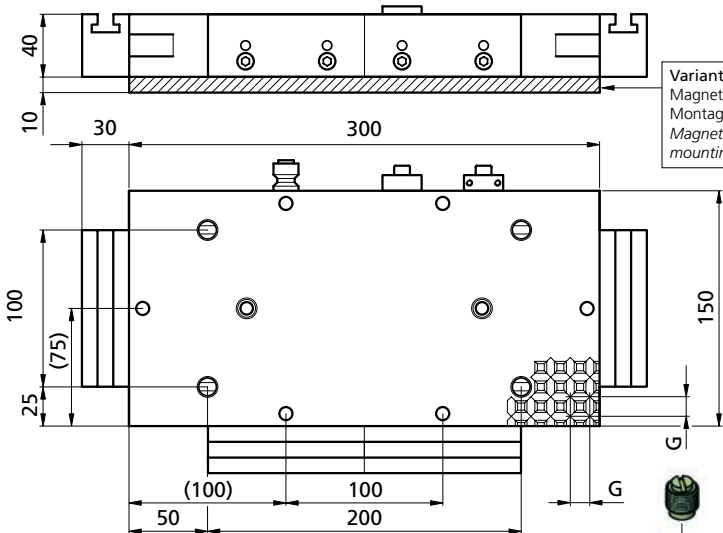

Variante / Variant:
Magnetische Befestigung auf Montageplatte
Magnetical fastening on mounting plate



| G13 | |
|------------------|------------------|
| UP15030040R50G13 | |
| 1 | 1x TH150942 |
| 2 | 2x 0700100 |
| 3 | 1x 1110100 |
| 4 | 5x 0920000 |
| 5 | 6x 1111003 |
| 6 | 6x M10X12ISO4027 |
| 7 | 4x M6X35ISO4762 |
| 8 | 1x 0910001 |
| 9 | 4x 0700102 |
| 10 | 4x ADAPT6-12 |
| G | = 12,5 mm |
| kg | ~4,6 |

UP15030040R50G13

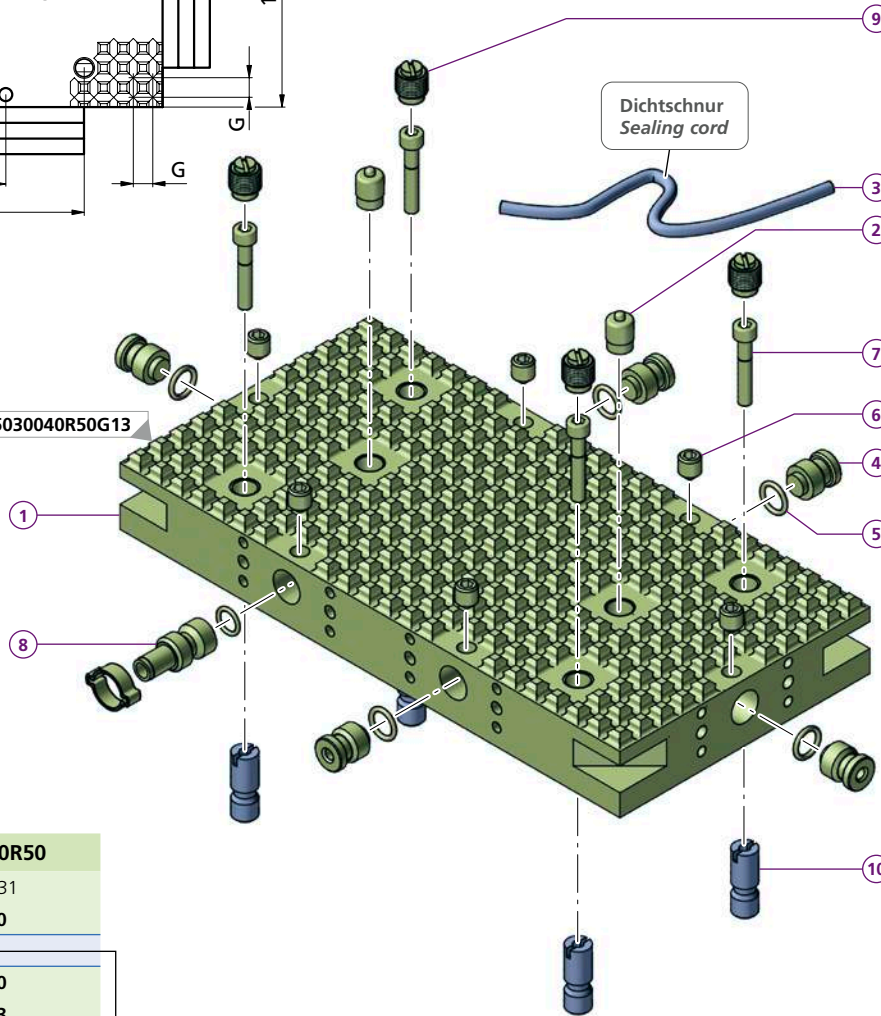

| G06 | |
|------------------|-------------|
| UP15030040R50G06 | |
| 1 | 1x TH160132 |
| 3 | 1x 1120100 |
| G | = 6,5 mm |
| kg | ~4,8 |

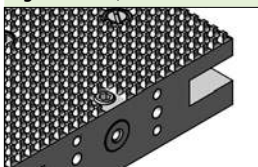

| UF15030050R50 | |
|---------------|------------------|
| 1 | 1x TH160131 |
| 2 | 2x 0700100 |
| 3 | 1x |
| 4 | 5x 0920000 |
| 5 | 6x 1111003 |
| 6 | 6x M10X12ISO4027 |
| 7 | 4x M6X35ISO4762 |
| 8 | 1x 0910001 |
| 9 | 4x 0700102 |
| kg | ~6 |

Bestellbeispiel / Ordering example:

UP15030040R50G13 & 1x ADAPT6-12 & 1x 1110100

Profilfräser / Carbide end mills G13 / G06 p. 324

Dichtschnüre je nach Bedarf / Sealing cords as needed

Separat bestellen / Order separately

Vakuum-Modul für powerCLAMP

Vacuum module for powerCLAMP

PS1X150L60-VAC *trivaCLAMP*

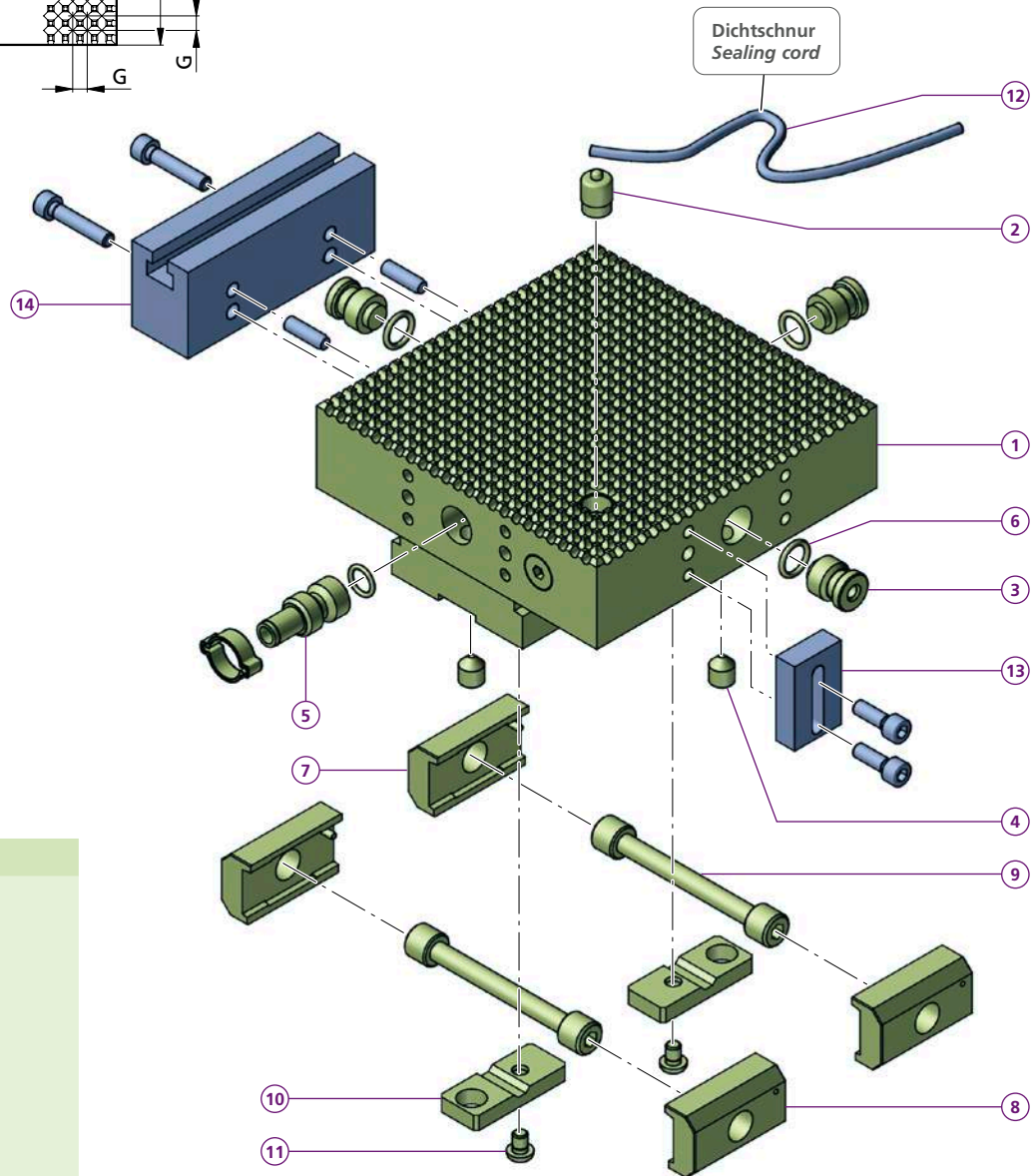
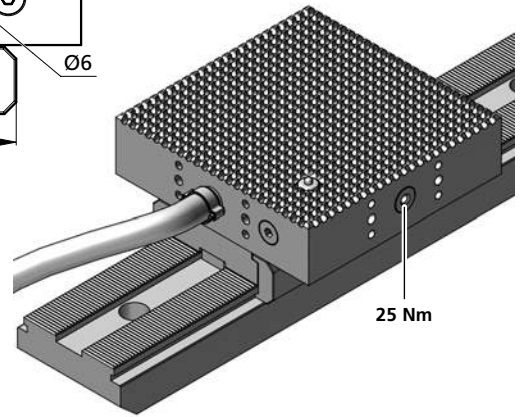
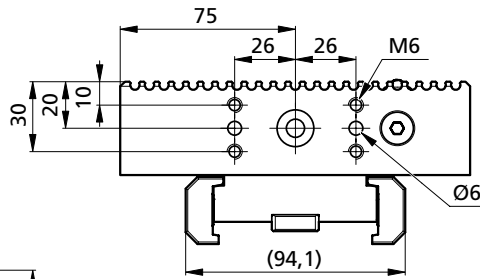
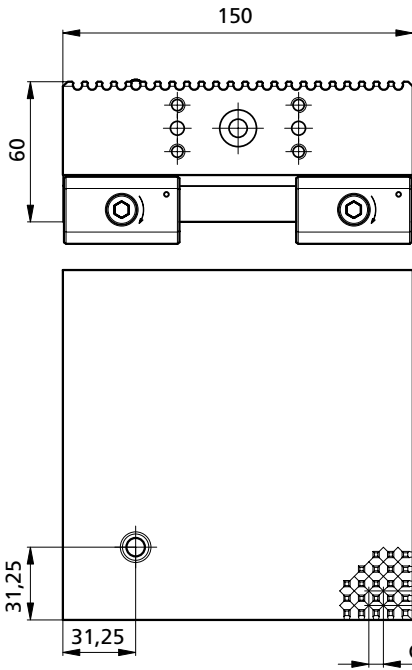

PS1X150L60-VAC

- 1x TW090017-01
 - 1x 0700100
 - 3x 0920000
 - 4x M10X12ISO4027
 - 1x 0910001
 - 5x 1111003
 - 2x PCSP50R
 - 2x PCSP50L
 - 2x PCS14
 - 2x PCGU2049
 - 2x M6X8ISO7380
 - 1x 1120100 **p. 324**
 - 1x UA182540 **p. 322**
 - 1x UT1003040
- G = 6,5 mm
kg ~3,6

Bestellbeispiel / Ordering example:
PS1X150L60-VAC & 1x 1120100 & 1x UA182540 & 1x UT1003040

Separat bestellen / Order separately

Vakuum-Modul für powerCLAMP Vacuum module for powerCLAMP

PS1X80L31-VAC

trivaCLAMP

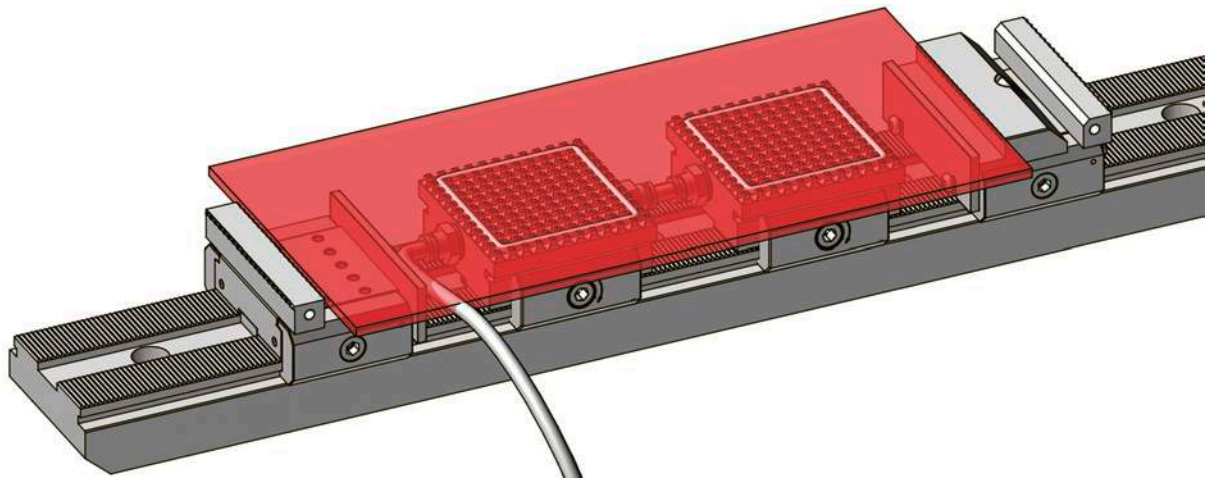
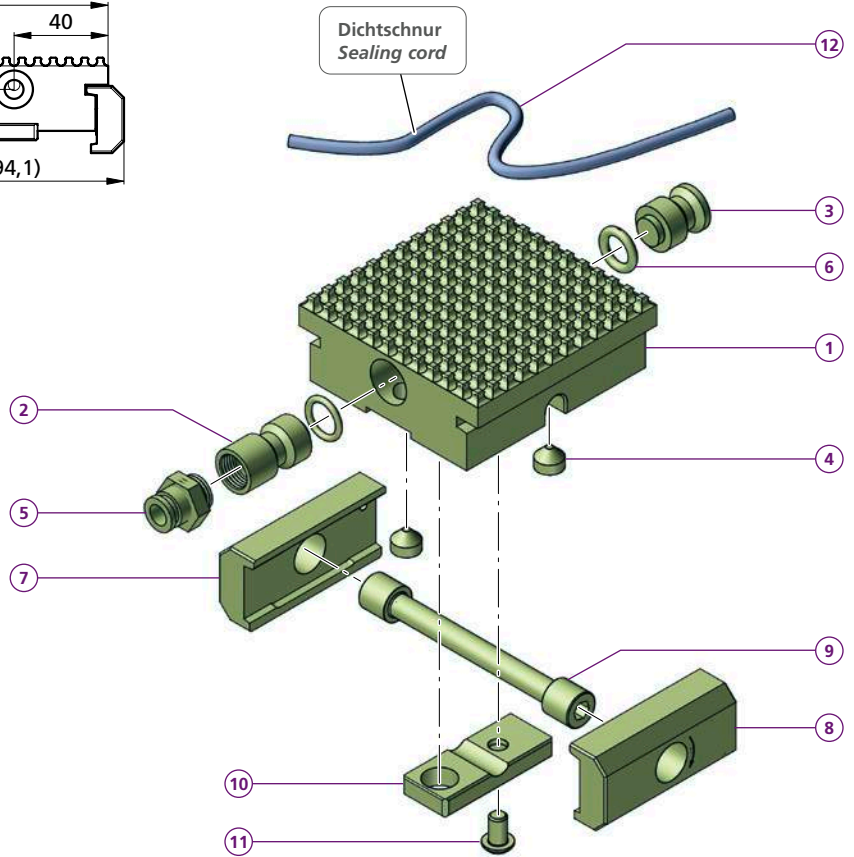
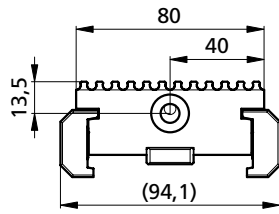
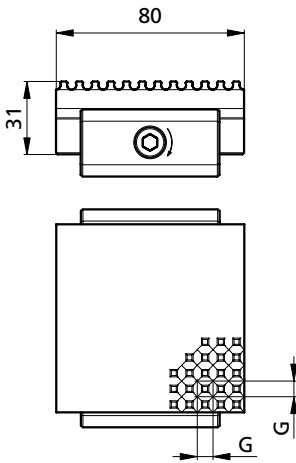

PS1X80L31-VAC

- 1 1x TH140263
- 2 1x UZV16301/4
- 3 1x 0920000
- 4 2x M10X8DIN914
- 5 1x QSG1/4-8
- 6 2x 1111003
- 7 1x PCSP60R
- 8 1x PCSP60L
- 9 1x PCS14
- 10 1x PCGU2049
- 11 1x M6X8ISO7380
- 12 1x 1120100

G = 6,5 mm

kg ~0,62

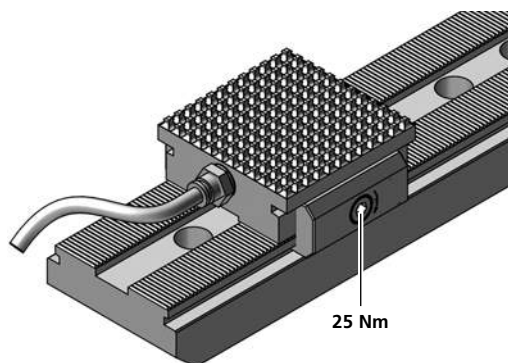

Bestellbeispiel / Ordering example: PS1X80L31-VAC & 1x 1120100

Kombinationsvarianten (Vakuumplatten)

Possible combination of vacuum plates

trivaCLAMP

UP15030040R50 G06 / G13

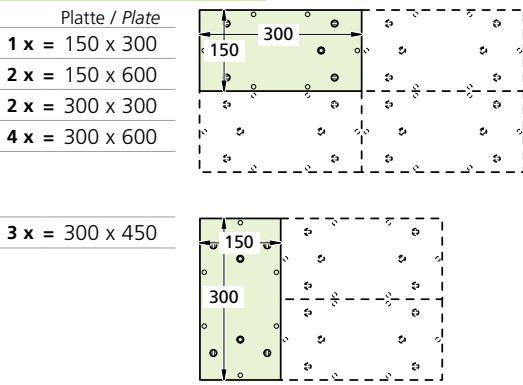

UP20030040R50 G06 / G13

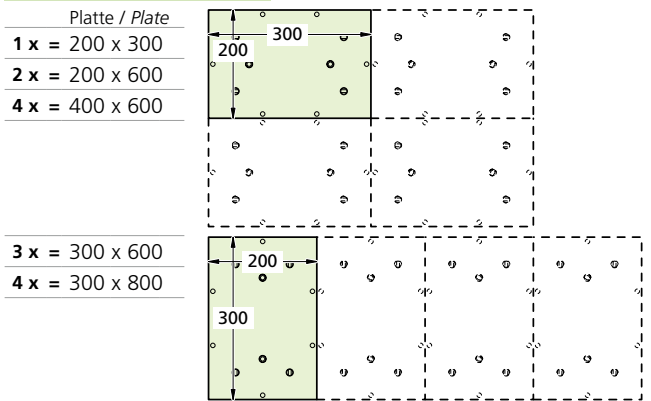

UP30060040R50 G06 / G13

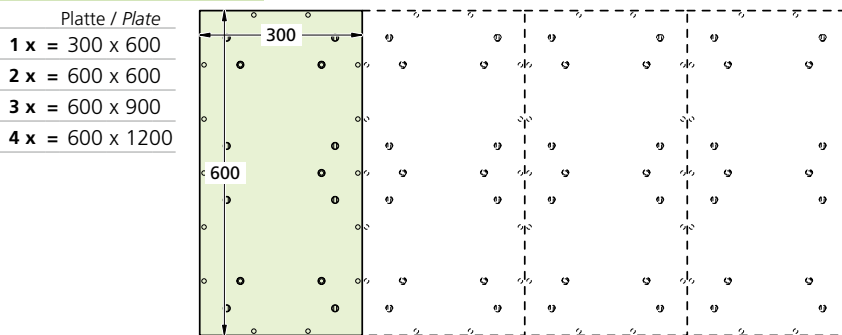

UP30060040R50 G06 / G13

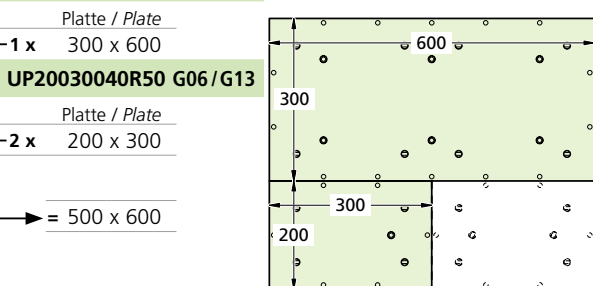

UP30060040R50 G06 / G13

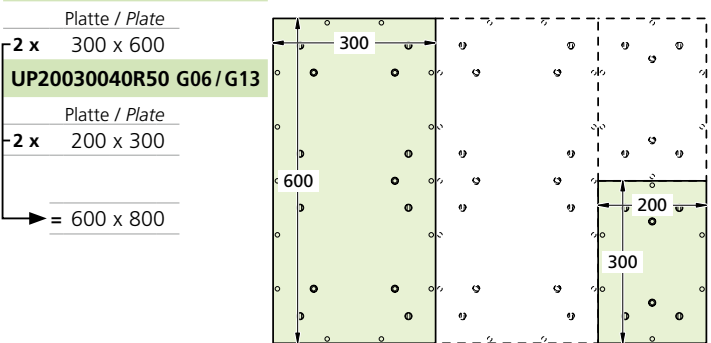

UP50050040R50 G06 / G13

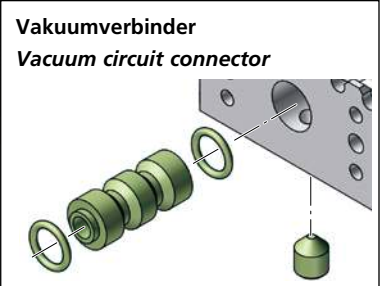
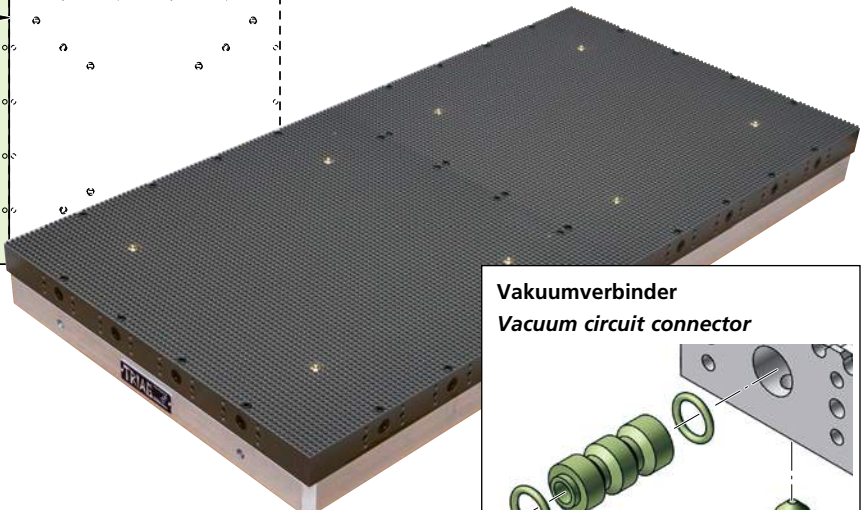
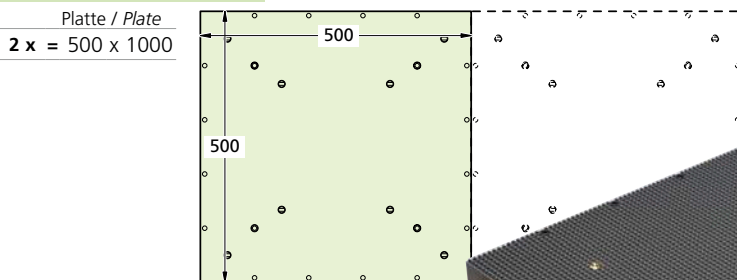

| UPSET | D | 1 | V | G... | |
|--|---|--|---|--|--|
| <p>A UP50050040R50G13 500 500 UF50050050R50 G</p> <p>B UP30060040R50G13 300 600 UF30060050R50 H</p> <p>C UP20030040R50G13 200 300 UF20030050R50 I</p> <p>D UP15030040R50G13 150 300 UF15030050R50 J</p> <p>E PS1X150L60-VAC G06</p> <p>F PS1X80L31-VAC G06</p> | <p>1 UPB1JN 1</p> <p>2 UPB2JN 2</p> <p>3-5 UBA ...</p> | <p>UA3-660</p> <p>UT1003040 V</p> <p>UA0770</p> <p>UZA5015G13</p> <p>UZA4012G06</p> <p>UA182540</p> | <p>G13 G06</p> <p>Vakuumpalte Vacuum plate</p> <p>A 500 x 500 (UP50050040R50 G06 / G13) B 300 x 600 (UP30060040R50 G06 / G13) C 200 x 300 (UP20030040R50 G06 / G13) D 150 x 300 (UP15030040R50 G06 / G13) E 150 x 60 (PS1X150L60-VAC) F 80 x 31 (PS1X80L31-VAC) G 500 X 500 (UF50050050R50) H 300 X 600 (UF30060050R50) I 200 X 300 (UF20030050R50) J 150 X 300 (UF15030050R50)</p> | <p>Vakuum erzeugen Generate vacuum</p> <p>1 UPB1JN 2 UPB2JN 3 UBA106230300 4 UBA106110250 5 UBA318400550</p> | <p>Zubehör Accessories</p> <p>Z 2x UT1003040 1x UA182540 1x UA3-660 Y 2x UT1003040 1x UA182540 1x UA3-560 X 2x UT1003040 1x UA182540 1x UA3-360 W 2x UT1003040 1x UA182540 1x UA2-260 V 2x UT1003040 1x UA182540 2x UA0770 U 4x UZA4012G06 T 4x UZA5015G13</p> |
| <p>Zu jedem SET werden zusätzlich 3 m Vakuumschlauch (0941000) und 25 m Dichtschnur mitgeliefert (1120100) Ø 4 oder (1110100) 6 mm inkl. (2 x 10100024). Each SET is supplied with an additional 3 m vacuum hose (0941000) and 25 m sealing cord (1120100) Ø 4 or (1110100) 6 mm incl. (2 x 10100024).</p> <p>Vakuumschlauch Vacuum hose 3 m: 0941000</p> <p>Dichtschnur Sealing cord 25 m: 1120100</p> <p>Bestellbeispiel / Ordering example: UPSETD1VG13</p> | | | | | |

Anschlagleisten
Stop rails

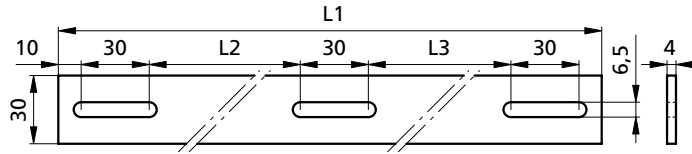

| UA3-660 | |
|---------|-----------------|
| 1 | 1x TH160274 |
| 2 | 3x M6X12ISO4762 |
| 3 | 3x 6,4 DIN9021 |
| 4 | 3x SM1135M6X8 |
| L1 | = 660 mm |
| L2 | = 270 mm |
| L3 | = 280 mm |
| kg | ~0,6 |

| UA3-560 | |
|---------|-----------------|
| 1 | 1x TH160275 |
| 2 | 3x M6X12ISO4762 |
| 3 | 3x 6,4 DIN9021 |
| 4 | 3x SM1135M6X8 |
| L1 | = 560 mm |
| L2 | = 225 mm |
| L3 | = 225 mm |
| kg | ~0,5 |

| UA3-360 | |
|---------|-----------------|
| 1 | 1x TH160277 |
| 2 | 3x M6X12ISO4762 |
| 3 | 3x 6,4 DIN9021 |
| 4 | 3x SM1135M6X8 |
| L1 | = 360 mm |
| L2 | = 120 mm |
| L3 | = 130 mm |
| kg | ~0,32 |

| UA2-260 | |
|---------|-----------------|
| 1 | 1x TH160278 |
| 2 | 2x M6X12ISO4762 |
| 3 | 2x 6,4 DIN9021 |
| 4 | 2x SM1135M6X8 |
| L1 | = 260 mm |
| L2 | = 180 mm |
| kg | ~0,2 |

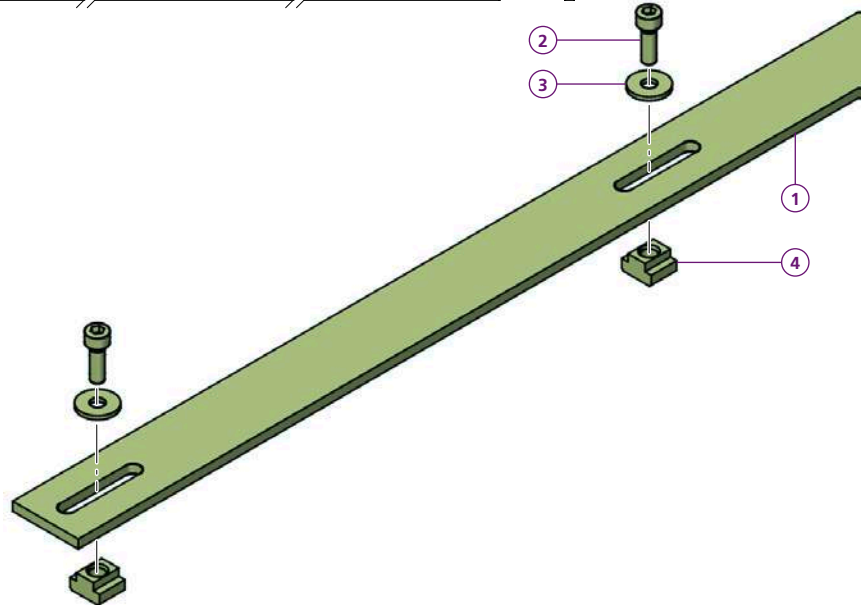

Anschlag
Stop rail

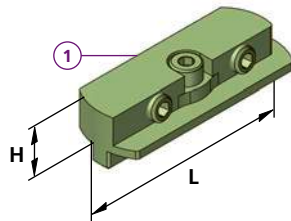

| UZA5015G13 | |
|------------|-------------|
| 1 | 1x TB170561 |
| L | = 50 mm |
| H | = 9 mm |
| kg | ~0,04 |



Bedienungsanleitung zu diesen zwei Anschlägen
Operating instructions for these two stops

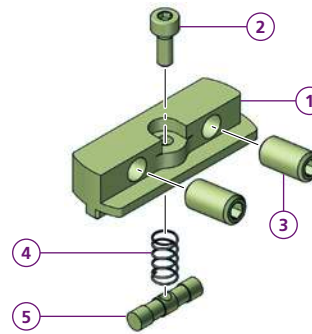

| UZA4012G06 | |
|------------|-----------------|
| 1 | 1x TB170558 |
| 2 | 1x M4X10ISO4762 |
| 3 | 2x M6X16 DIN913 |
| 4 | 1x TN100535 |
| 5 | 1x TB170562 |
| L | = 40 mm |
| H | = 8,5 mm |
| kg | ~0,03 |

T-Nuten Stein
T-nuts

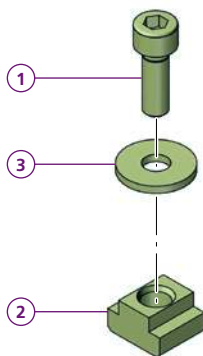

| 0802000-SET | |
|-------------|-----------------|
| 1 | 1x M6X12ISO4762 |
| 2 | 1x SM1135M6X8 |
| 3 | 1x 6,4 DIN9021 |
| kg | ~0,03 |

Ansetzbare T-Nuten
Attachable T-slots

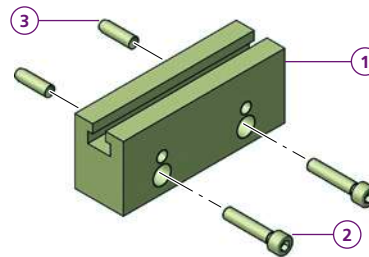

| UT1003040 | |
|-----------|-------------------|
| 1 | 1x TH160227 |
| 2 | 2x M6X25ISO4762 |
| 3 | 2x 6X20-B ISO8734 |
| kg | ~0,4 |

Seiten-/Wendeanschlag
Reversible stop gage

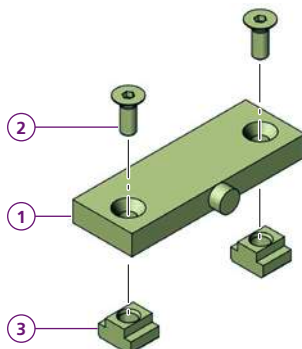

| UA0770 | |
|--------|---------------|
| 1 | 1x TH160259 |
| 2 | 2x TN100899 |
| 3 | 2x SM1135M6X8 |
| kg | ~0,14 |

Seitenanschlag
Side lay

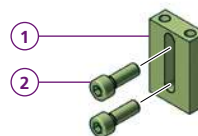

| UA182540 | |
|----------|-----------------|
| 1 | 1x TH160098 |
| 2 | 2x M6X18ISO4762 |
| kg | ~0,1 |

Vakuumverbinder Vacuum circuit connector

Koppelemente Link-up plug

trivaCLAMP

Vakuumverbinder
Vacuum circuit connector

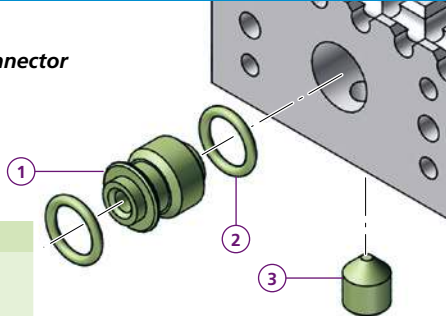

- 0930000**
- ① 1x TK110401
 - ② 2x 1111003
 - ③ 1x M10X12ISO4027
- kg ~0,02

Blindstopfen
Blind plug

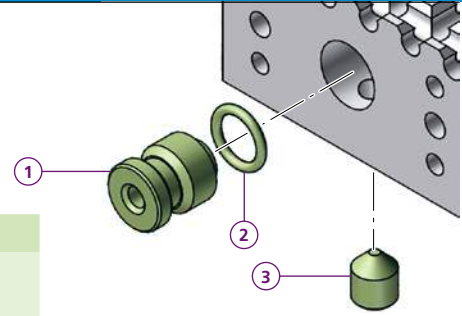

- 0920000**
- ① 1x TK110402
 - ② 1x 1111003
 - ③ 1x M10X12ISO4027
- kg ~0,03

Koppelement
Link-up plug

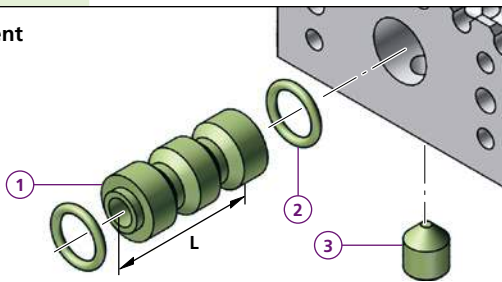

- 0910000**
- ① 1x TK110403
 - ② 2x 1111003
 - ③ 1x M10X12ISO4027
- L = 40 mm
- kg ~0,03

- 0910080**
- ① 1x TK140763
 - ② 2x 1111003
 - ③ 1x M10X12ISO4027
- L = 80 mm
- kg ~0,04

Vakuumverbinder
Vacuum circuit connector

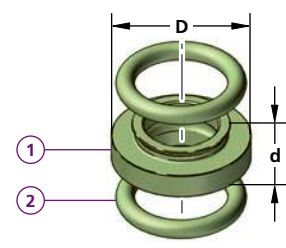

- TS150487**
- ① 1x TS150487
 - ② 2x TN100682
- d = 5,8 mm
- D = 15 mm

Vakuumschlauch (per Laufmeter)
Vacuum hose (per running meter)

- D = 8 mm für Vakuumanbindung von Platte zu Platte
for vacuum supply from plates to accessories
- D = 16 mm für Vakuumverbindung von Pumpe zu Platten
for vacuum supply from pump to plate

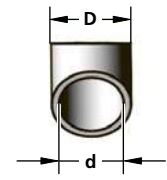

- | | |
|----------------|----------------|
| 0940800 | 0941000 |
| D = 8 mm | D = 16 mm |
| d = 5,5 mm | d = 10 mm |

Anschlüsselement
Adapter element

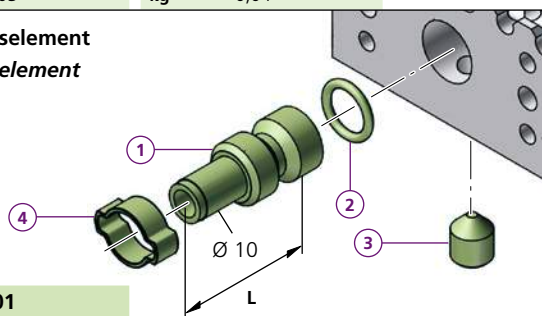

- 0910001**
- ① 1x TK110404
 - ② 1x 1111003
 - ③ 1x M10X12ISO4027
 - ④ 1x 10100024
- L = 40 mm
- kg ~0,04

Verbindungsschlauch mit Koppelementen
Connector-tube with link-ups

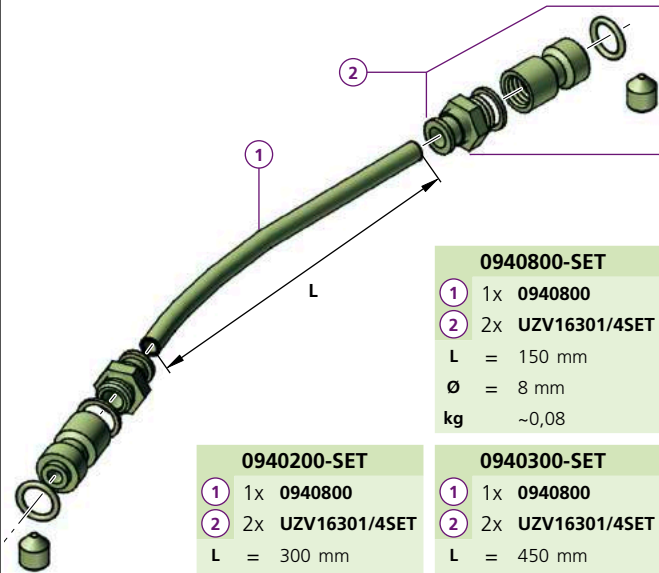

- 0940800-SET**
- ① 1x 0940800
 - ② 2x UZV16301/4SET
- L = 150 mm
- Ø = 8 mm
- kg ~0,08

- 0940200-SET**
- ① 1x 0940800
 - ② 2x UZV16301/4SET
- L = 300 mm
- Ø = 8 mm
- kg ~0,08

- 0940300-SET**
- ① 1x 0940800
 - ② 2x UZV16301/4SET
- L = 450 mm
- Ø = 8 mm
- kg ~0,09

Vakuumverbinder
Vacuum circuit connector

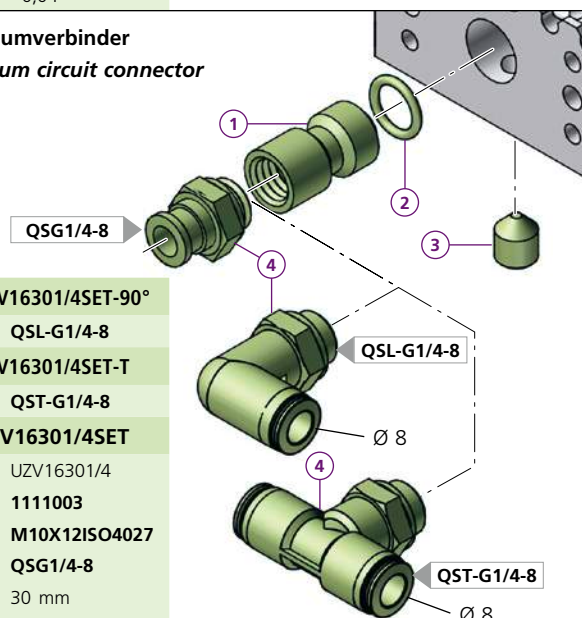

- UZV16301/4SET-90°**
- ④ 1x QSL-G1/4-8
- UZV16301/4SET-T**
- ④ 1x QST-G1/4-8
- UZV16301/4SET**
- ① 1x UZV16301/4
 - ② 1x 1111003
 - ③ 1x M10X12ISO4027
 - ④ 1x QSG1/4-8
- L = 30 mm
- kg ~0,024

Dichtschnüre aus Silikon-Gummi

Beständig gegen Öle, Säuren, Emulsionen, Dielektrika, ionisiertes Wasser und Wärme bis 200°C

Silicone-rubber sealing cord

Resistant to oils, acids, coolants, dielectrics, activated water (EDM) and heat up to 200°C

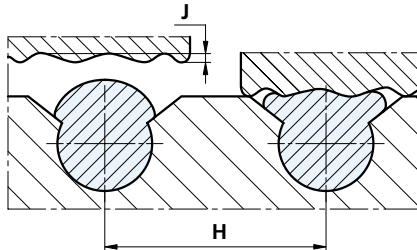

Dichtschnüre aus Gummi

- ölbeständig
- für spezielle Vorrichtungen

Rubber sealing cord

- oil resistance
- to fit special devices

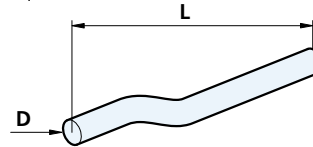

G13



G06

weiss / white

| 1110100 | 1120100 | 1120100M | 1130000 |
|--------------------|--------------------------|--------------------------|----------|
| L = 25 m | L = 25 m | L = 25 m | L = 5 m |
| D = 6,5 mm ±0,5 | D = 4 mm (4,3-4,6 mm) | D = 4 mm (4,0-4,3 mm) | D = 3 mm |
| J = max. 0,6 mm | J = max. 0,4 mm | J = max. 0,3 mm | |
| H = 12-13 mm | H = 6-7 mm | H = 6-7 mm | |



G13

schwarz / black

weiss / white

| 1110100S | 1110100SP | 0130001 | 0130002 |
|-----------------|-----------------|-------------|-------------|
| L = 25 m | L = 25 m | L = 1 m | L = 1 m |
| D = 6,0-6,5 mm | D = 6,6-7,0 mm | D = 2,15 mm | D = 1,65 mm |
| J = max. 0,6 mm | J = max. 0,6 mm | | |
| H = 12-13 mm | H = 12-13 mm | | |

Triva Clamp Ventil / Triva Clamp valve

Montage von oben
Mounting from above

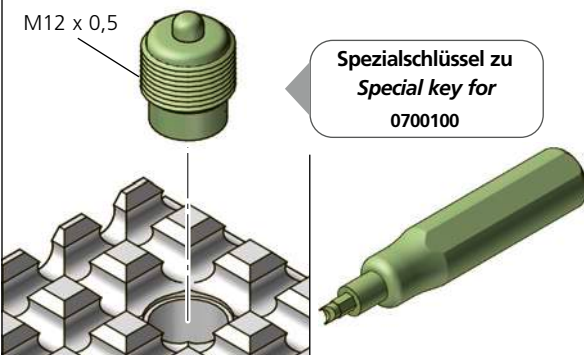

| | | | | | |
|---------|----|-------|-----------|----|-------|
| 0700100 | kg | ~0,01 | Triva Bit | kg | ~0,14 |
|---------|----|-------|-----------|----|-------|

Ventil-Blindstopfen
Valve blind plug

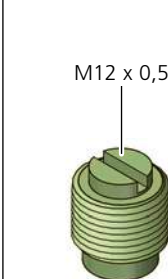

| | | |
|---------|----|-------|
| 0700102 | kg | ~0,01 |
|---------|----|-------|

Montage von unten, für Spezialvorrichtungen
Mounting from bottom side, for special devices

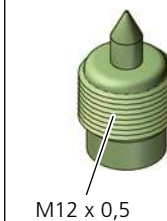

| | | |
|---------|----|-------|
| 0700200 | kg | ~0,01 |
|---------|----|-------|

Reduktionstück für Rasterplatten M12/12^{f7} auf M6
Adapter piece for Gridplates from M12/12^{f7} to M6

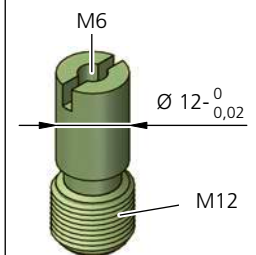

| | | |
|-----------|----|-------|
| ADAPT6-12 | kg | ~0,02 |
|-----------|----|-------|

Schnellkupplung mit Bride Quick hose coupling including clip

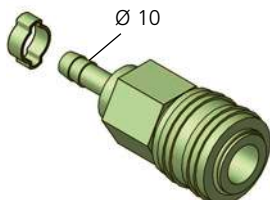

| | | |
|---------|----|-------|
| 0520000 | kg | ~0,14 |
|---------|----|-------|

Schlauchnippel mit Bride Hose nozzle including clip

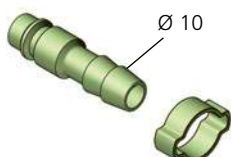

| | | |
|---------|----|-------|
| 0941010 | kg | ~0,03 |
|---------|----|-------|

VHM Profilfräser für Vorrichtungplatten Carbide end mills for plate for dedicated fixtures

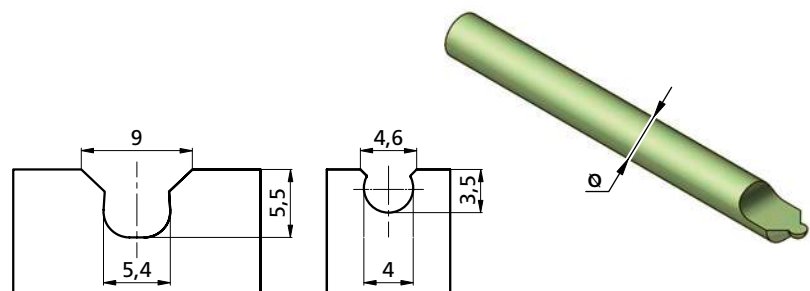

G13

VFP10065L100 (Ø 6,5 mm)

| |
|---------|
| Ø = 10 |
| L = 100 |



G06

VFP08040L90 (Ø 4 mm)

| |
|--------|
| Ø = 8 |
| L = 90 |

Rotationspumpe auf Speichertank für Arbeiten mit Kühlwasser

Aggregat ausgerüstet mit:

- Vakuumpumpe, Enddruck 20 mbar
- Wasserabscheider mit Sintermetallfilter
- Fahrbarem 50 Liter Behälter als Vakuumspeicher und Wasserreservoir
- 5 Meter Vakuumschlauch
- für 3-Phasenbetrieb wartungsfreie Drehstrommotoren
- für 1-Phasenbetrieb wartungsfreie Motoren mit Anlauf-Kondensatoren.

für Vakuumaufspannflächen:

- zusammenhängend, oder auf mehrere einzelne Platten verteilt

Rotary pumptank assembly Pump assembly for machining with flowing coolant

Assembly equipped with:

- Vacuum pump, pressure limit 20 mbar
- Liquid separator with sintered metall filter
- Pump mounted on a movable 50l (13gal) tank being both, vacuum reservoir and water collector
- 5 m (6.5ft) Vacuum hose
- maintenance-free motors for 3 phase operating
- single phase motors with capacitor starter.

To cover maximum holding surface:

- built by plate or plate-assembly, or display over several single plates mounted to various machine-tools

Technische Daten
Technical data

Saugkraft
Suction capacity

Spannfläche bis / Surface up to 1,8 m²

| | | |
|--|---------------------------|---------------------|
| 3-Phasen / Triple phase 400 V ± 10%, 50 / 60 Hz, 250 / 300 W | 6 / 7,2 m ³ /h | UBA306400250 |
| 1-Phasen / Single phase 230 V ± 10%, 50 / 60 Hz, 300 / 360 W | 6 / 7,2 m ³ /h | UBA106230300 |
| 1-Phasen / Single phase 110 V ± 10%, 60 Hz, 250 / 300 W | 6 / 7,2 m ³ /h | UBA106110250 |

Spannfläche bis / Surface up to 5,0 m²

| | | |
|--|---------------------------|---------------------|
| 3-Phasen / Triple phase 400 V ± 10%, 50 / 60 Hz, 550 / 660 W | 18 / 21 m ³ /h | UBA318400550 |
| 1-Phasen / Single phase 230 V ± 10%, 50 / 60 Hz, 600 / 720 W | 18 / 21 m ³ /h | UBA118230600 |

Separater Tank / Separate tank

| |
|--------------|
| UBT40 |
| Vol. 40l |

Öl für Vakuumpumpe / Oil for vacuum pump

| |
|----------------|
| UB1-OIL |
| Vol. 1l |



Bedienungsanleitung zu diesem Vakuumpumpen
Operating instructions for this vacuum pump

➔ Größere Pumpen auf Anfrage
➔ Larger pumps on demand

Schaltventil und Druckwächter

Control unit with pressure sensor switch

trivaCLAMP

Schaltventil
Control unit

TN100668 kg ~0,096

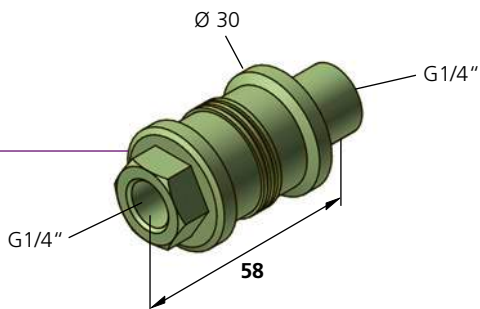

Schaltventil mit Unterdruckanzeige
Control unit valve with vacuum indicator

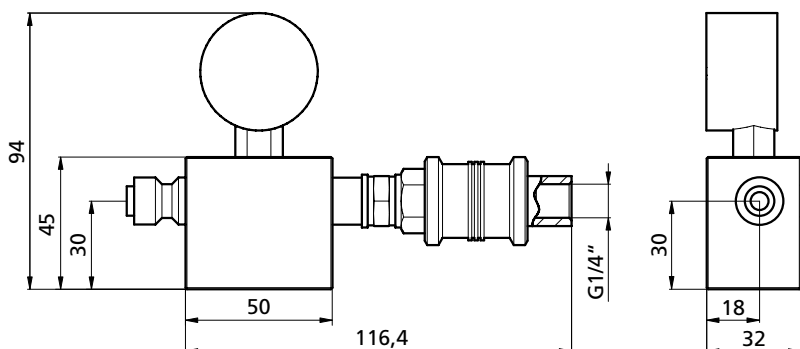

UBS5045

- 1 1x UBS5045-1
- 2 1x 0910000
- 3 3x TN100822
- 4 1x 0920000
- 5 3x TN100086
- 6 1x TN100671
- 7 2x TN100642
- 8 1x TN100925
- 9 1x TN100668
- 10 1x TH120180

kg ~0,74

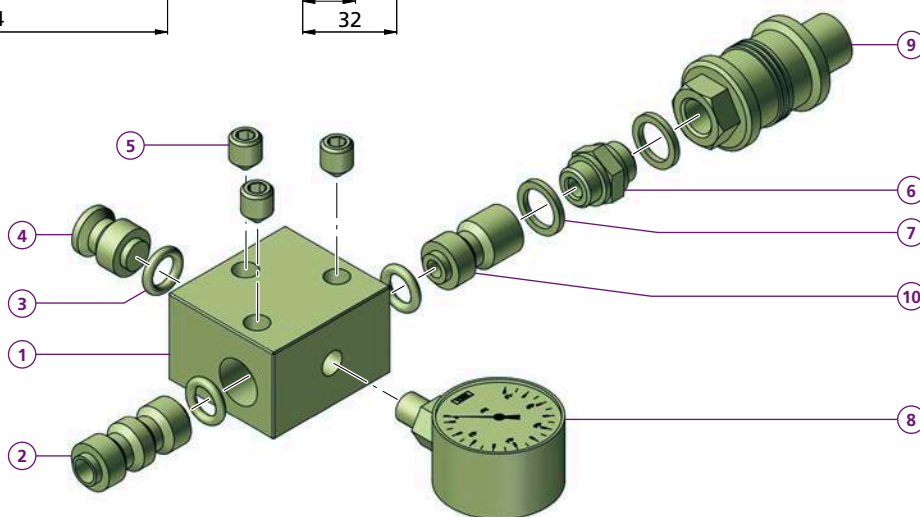

Druckwächter / Pressure sensor switch

Druck einstellbar; je nach Aufspannung einzustellen.

With adjustable threshold value; to be adjusted according to clamping task.

Anschluss 24-250 V, 50-60 Hz am Ausgang (R) für Elektrokabel zu optischem oder akustischem Warnsignal, oder zum Stillsetzen der Werkzeugmaschine über deren Steuerung, normalerweise mit Funktion M 00 (Programm Stop).

Power supply (24-250 V, 50-60 Hz). Connecting point (R) for wiring to trigger a signal (light or whistle) or to switch the machine tool off via its control system, normally using function M 00 (machine stop), in the event of a drop of vacuum.

Winkelanschluss / Elbow fitting

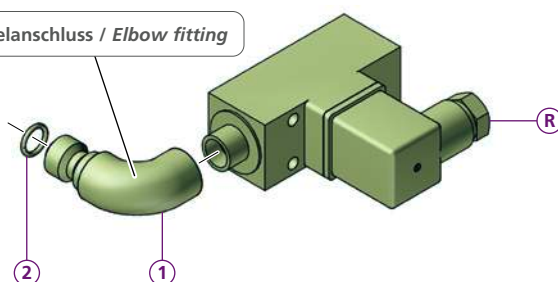

0500205

- 1 1x 0940000
- 2 1x 1111003

➔ Weiteres Zubehör auf Anfrage
➔ Further accessories on demand

Vakuumschleuse auf Power-Clamp mit Injektorpumpe für Trocken- und Nasseinsatz

Das modulare Triag Power Clamp Spannsystem kann nun mit Vakuumschleusen bestückt werden. Die Vakuumschleusen können mit oder ohne Zwischenräume gekoppelt werden. Die handliche Injektorpumpe wird mit Pressluft betrieben und kann im Trocken- oder Nasseinsatz verwendet werden.

Vacuum clamping plates on Power - Clamp with injector pump for dry and wet use

The modular Triag Power Clamp workholding system can now be equipped with vacuum plates. The vacuum plates can be coupled with or without gaps. The handy injector pump is operated with compressed air and can be used in dry and wet applications.

Maximaler zulässiger Speisedruck: 7 bar
Maximal erreichbares Vakuum: 0,92 bar

Maximum allowable supply pressure: 7 bar
Maximum attainable vacuum: 0,92 bar

Der Normalliter (NI) entspricht dem Volumen, das eine bestimmte Menge (Masse) Gas bei atmosphärischem Druck einnehmen würde. Die Durchflussmenge wird berechnet aus Volumen pro Zeit (NI/s) unter Normalbedingungen (atmosphärischer Druck, 20°C).

The normal litres (NI) is the volume that would take a certain amount (mass) of gas at atmospheric pressure. The flow rate is calculated as volume per time (NI/s) under normal conditions (atmospheric pressure, 20°C).

| Typ | Speisedruck | Luftverbrauch | Saugleistung bei 50% Vakuum | Saugleistung bei 90% Vakuum |
|--------|---------------|-----------------|-----------------------------|-----------------------------|
| Type | Feed pressure | Air consumption | Vacuum suction power at 50% | Vacuum suction power at 90% |
| | bar | NI/s | NI/s | NI/s |
| UPB1JN | 5 | 2,0 | 0,6 | 0,02 |
| | 6 | 2,3 | 0,5 | 0,03 |
| UPB2JN | 5 | 4,0 | 1,2 | 0,04 |
| | 6 | 4,6 | 1,0 | 0,06 |

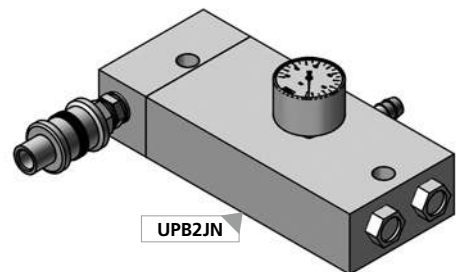
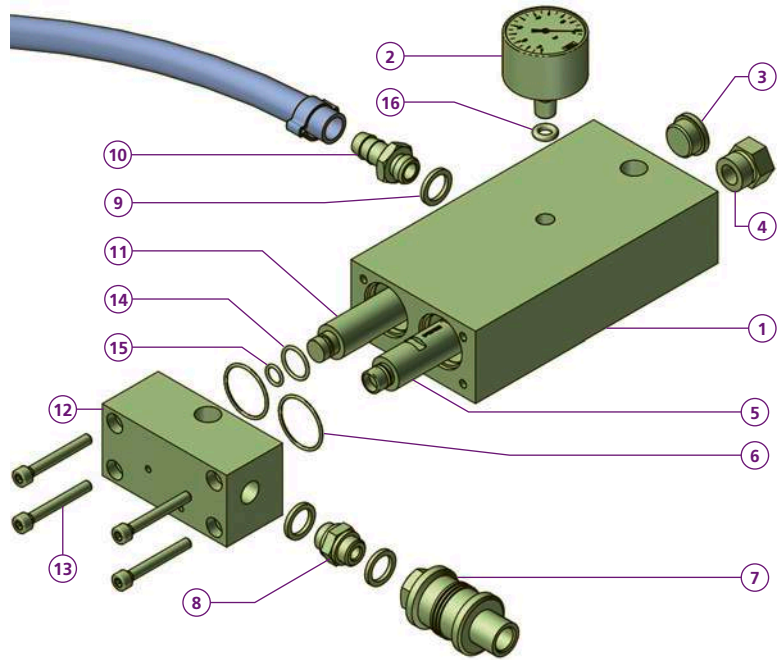
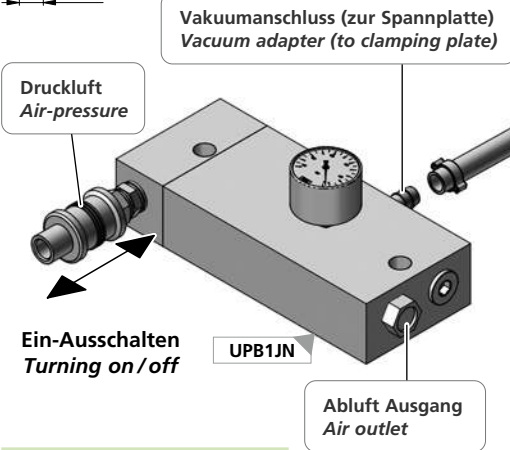
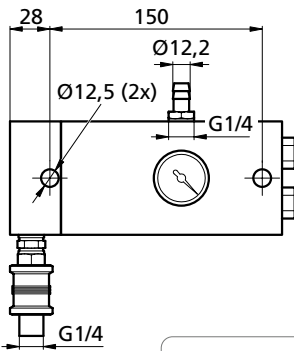
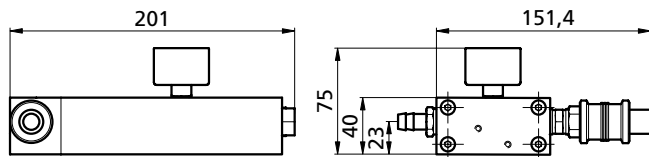

| UPB1JN | |
|--------|--------------------|
| 1 | 1x TW090057 |
| 2 | 1x TN100667 |
| 3 | 1x TN100660 |
| 4 | 1x TW100199 |
| 5 | 1x TN100665 |
| 6 | 2x TN100057 |
| 7 | 1x TN100668 |
| 8 | 1x TN100671 |
| 9 | 3x TN100642 |
| 10 | 1x TN100664 |
| 11 | 1x TW090057 |
| 12 | 1x TW90057-02 |
| 13 | 4x TN100666 |
| 14 | 1x TN100691 |
| 15 | 1x TN100163 |
| 16 | 1x TN100654 |
| kg | ~1,61 |

| UPB2JN | |
|--------|--------------------|
| 1 | 1x TW090057 |
| 2 | 1x TN100667 |
| 4 | 2x TW100199 |
| 5 | 2x TN100665 |
| 6 | 2x TN100057 |
| 7 | 1x TN100668 |
| 8 | 1x TN100671 |
| 9 | 3x TN100642 |
| 10 | 1x TN100664 |
| 12 | 1x TW90057-02 |
| 13 | 4x TN100666 |
| 14 | 1x TN100691 |
| 15 | 1x TN100163 |
| 16 | 1x TN100654 |
| kg | ~1,67 |

Bestellbeispiel / Ordering example: **UPB1JN**

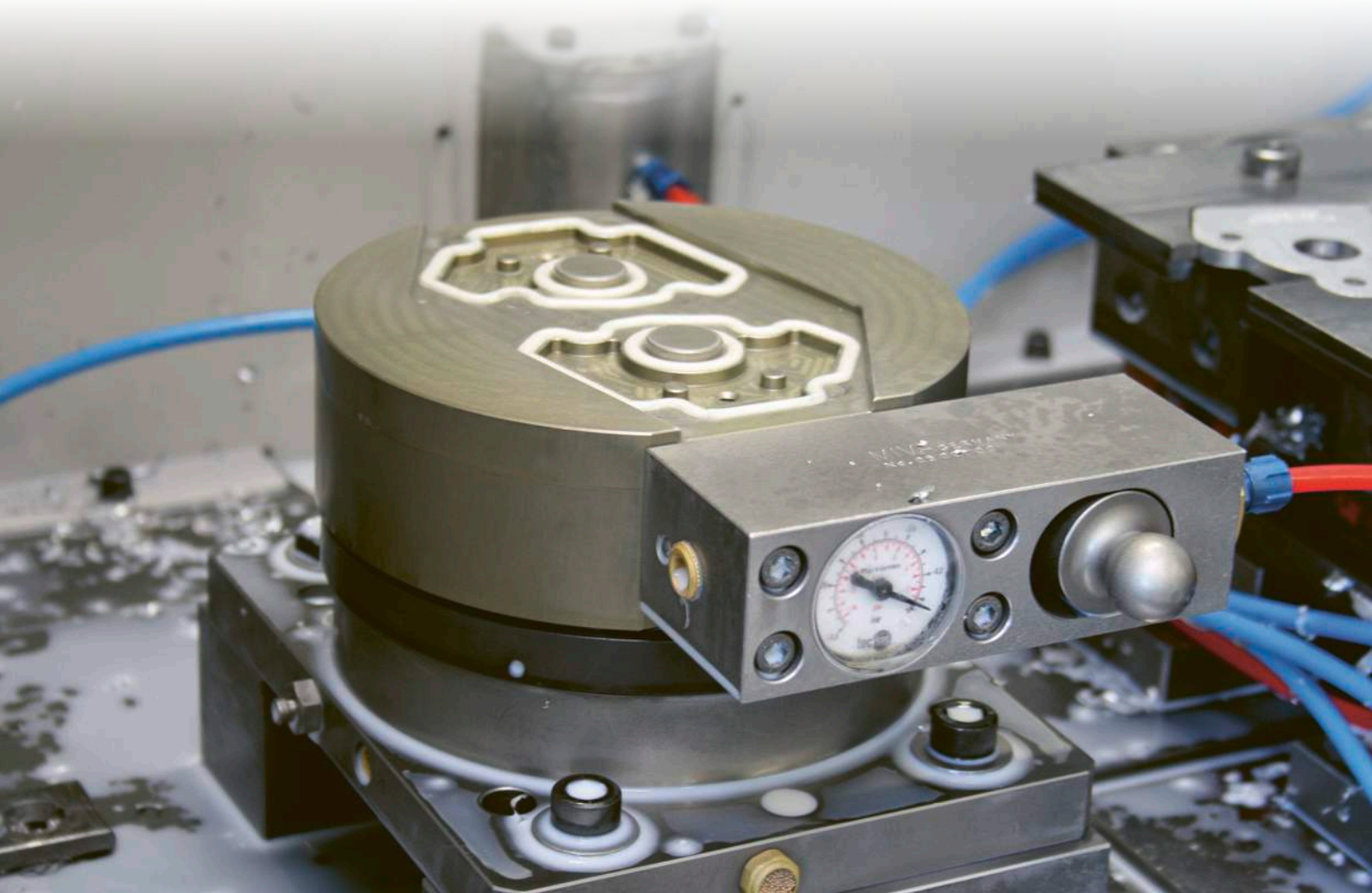



SPECIALS

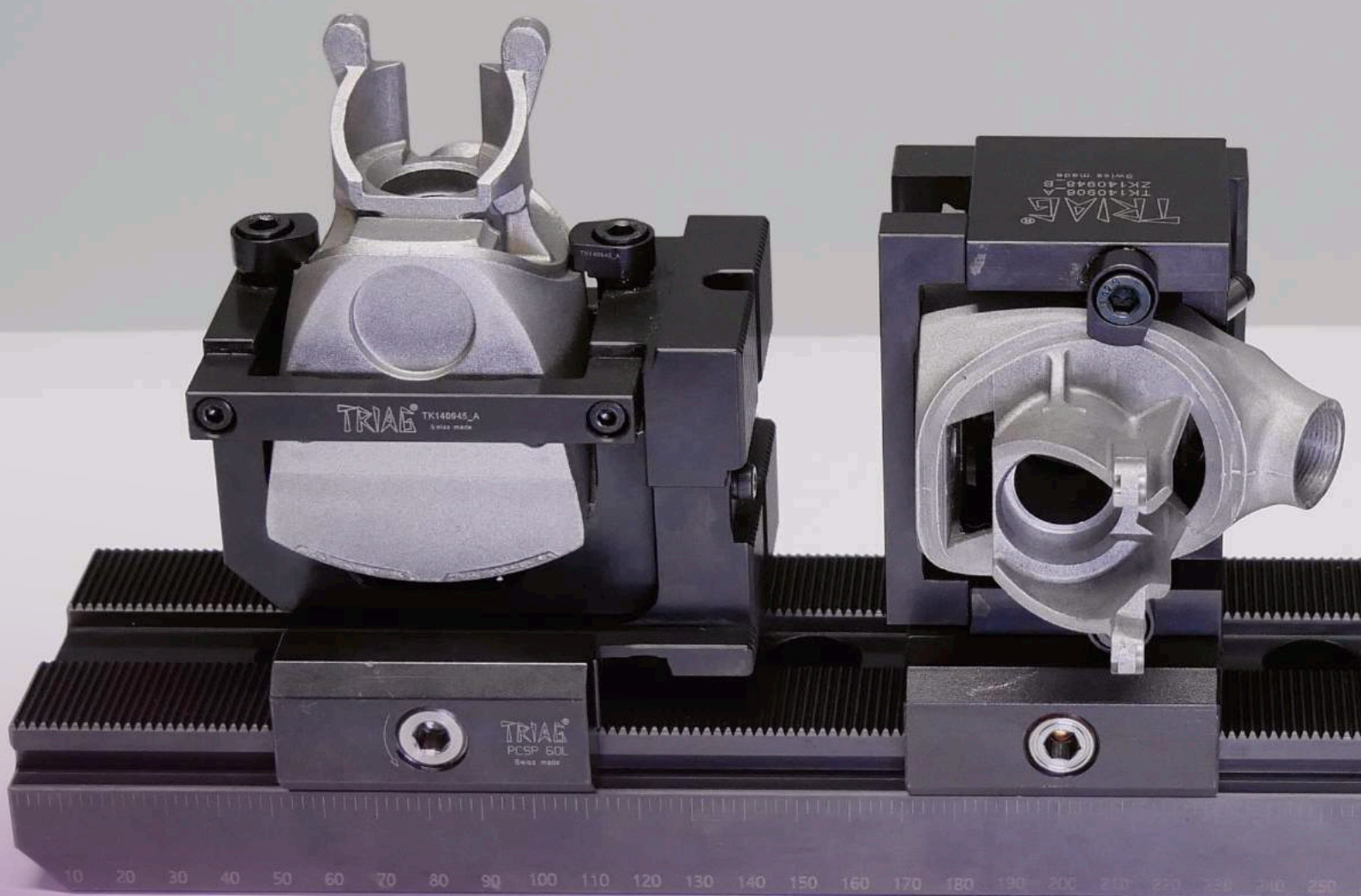

Fordern Sie uns heraus! *Challenge us!*



Wir sind Ihr Spezialist für Sondervorrichtungen.
Nehmen Sie mit uns Kontakt auf.

*We are your specialist for custom made fixtures.
Feel free to contact us.*



Komplexe Teile einfach gespannt *Complex parts simply clamped*



Drei Sonderspannmodule mit powerCLAMP Schnittstelle für komplex geformte Aluminium Druckguss Teile.

Three customized clamping modules with powerCLAMP interface for complex shaped die cast aluminium pieces.

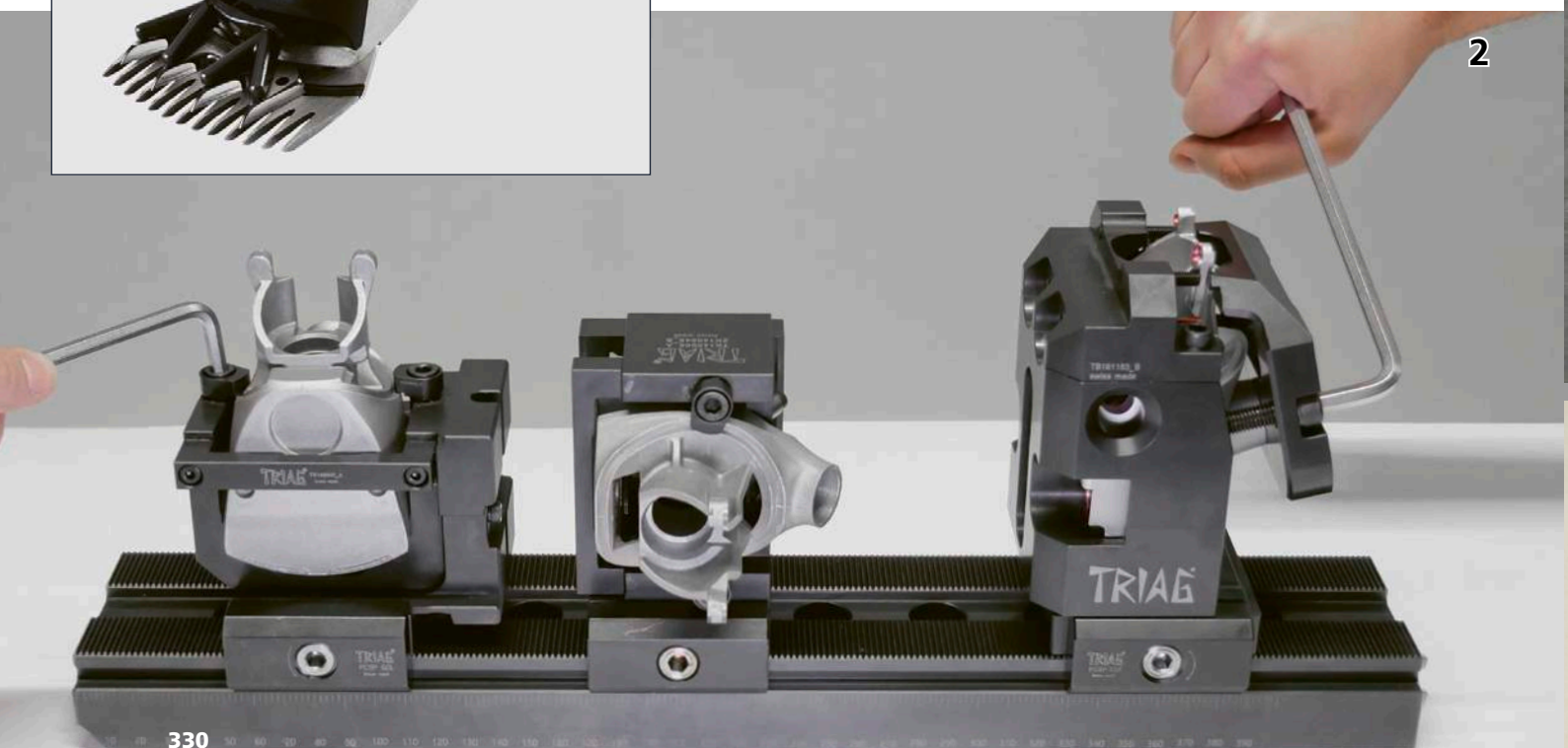

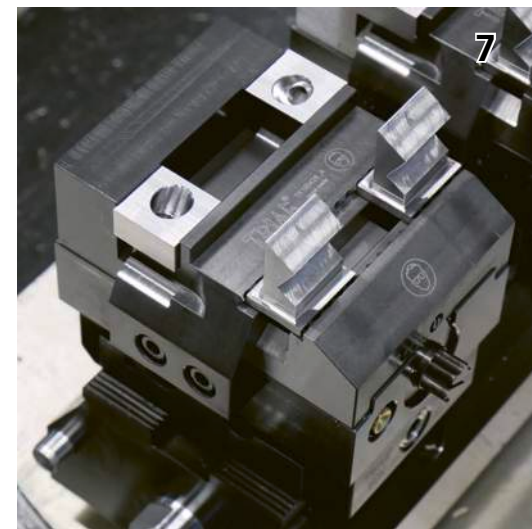
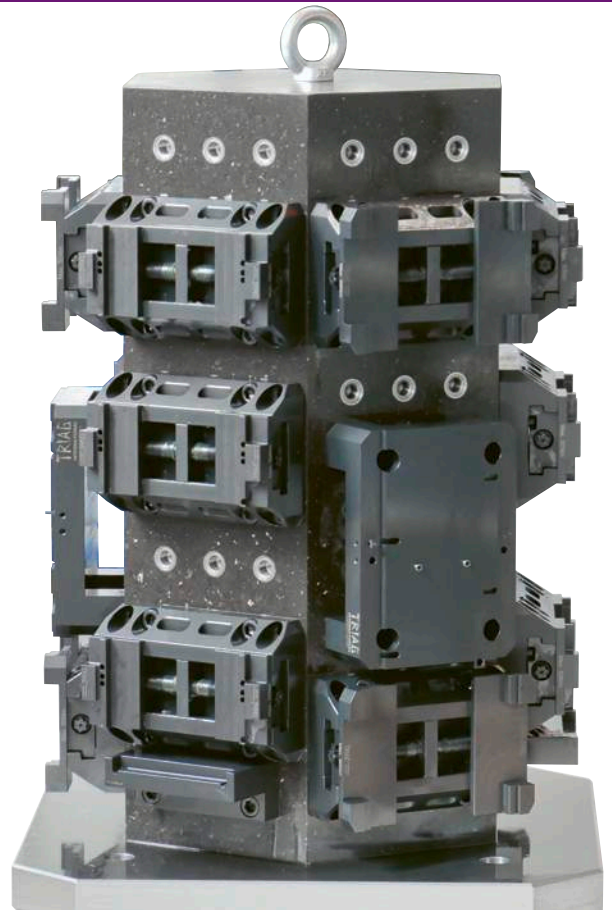



10



Zubehör Accessories

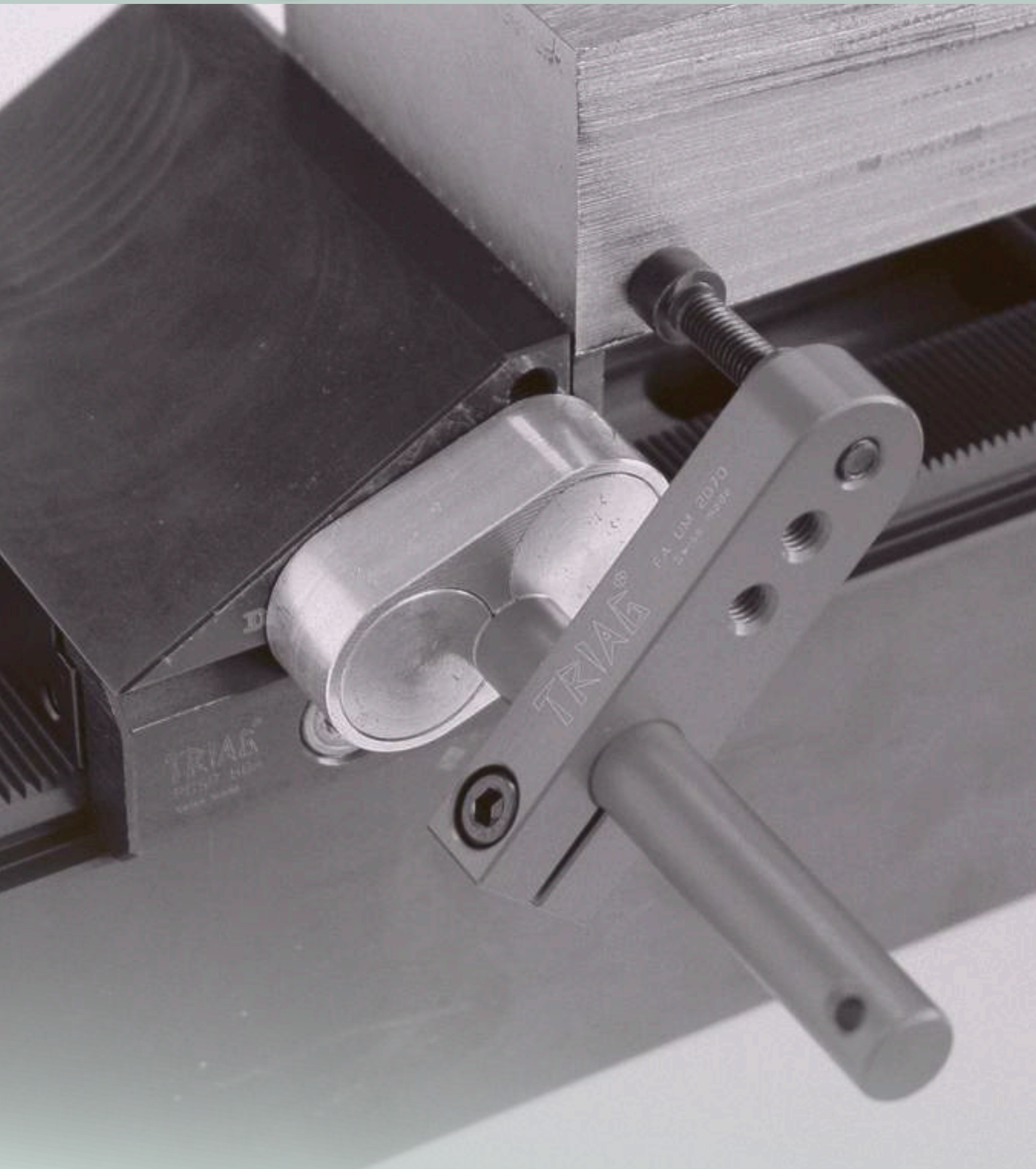

| | | |
|---|--|-----|
| Einstellmasstab <i>Measuring device</i> | | 335 |
| Magnetanschlag <i>Magnetic milling buffer</i> | | 336 |
| Fräsanschlag / Hartmetalldruckstück <i>Milling buffer / Carbide gripper</i> | | 337 |
| Stopfen / Spanschrauben / Passschrauben / T-Nuten Steine <i>Plug / Clamping screw / Fitting screw / T-slot nuts</i> | | 338 |
| Triag Bitburr / Magnethalter / Pneumatikschrauber Set <i>Magnetic holder / Pneumatic screwdrivers set</i> | | 339 |
| Drehmomentschlüssel / Spanschlüssel / Messingdrahtbürste <i>Torque wrenches / Clamping wrench / Brass wire brush</i> | | 340 |

Masstab mit Magnetleiste
Scale with magnet profile

- PCMAS800ML**
- ① 1x PCMAS800ML
 - ② 2x MG1645
 - ③ 2x M3X10ISO4762
 - ④ 1x M6X12BN5128
- kg ~1,0

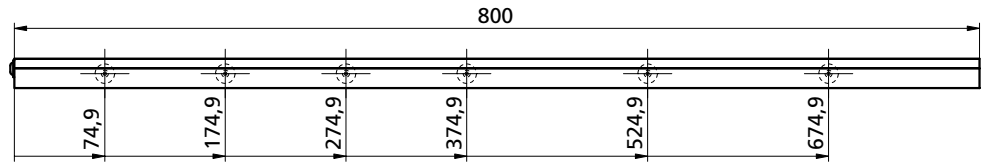

- PCMAS700ML**
- ① 1x PCMAS800ML
 - ② 2x MG1645
 - ③ 2x M3X10ISO4762
 - ④ 1x M6X12BN5128
- kg ~0,88

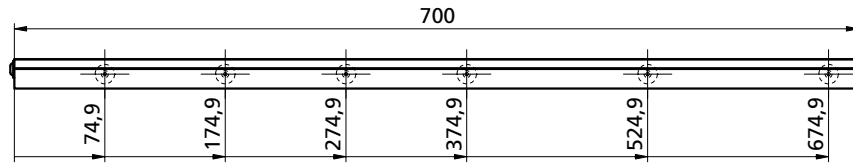

- PCMAS600ML**
- ① 1x PCMAS800ML
 - ② 2x MG1645
 - ③ 2x M3X10ISO4762
 - ④ 1x M6X12BN5128
- kg ~0,75

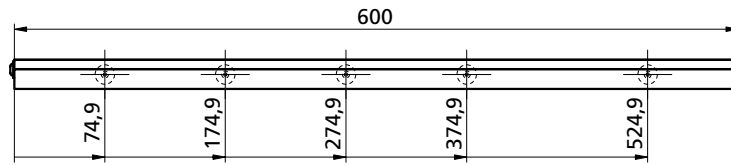

- PCMAS500ML**
- ① 1x PCMAS800ML
 - ② 2x MG1645
 - ③ 2x M3X10ISO4762
 - ④ 1x M6X12BN5128
- kg ~0,63

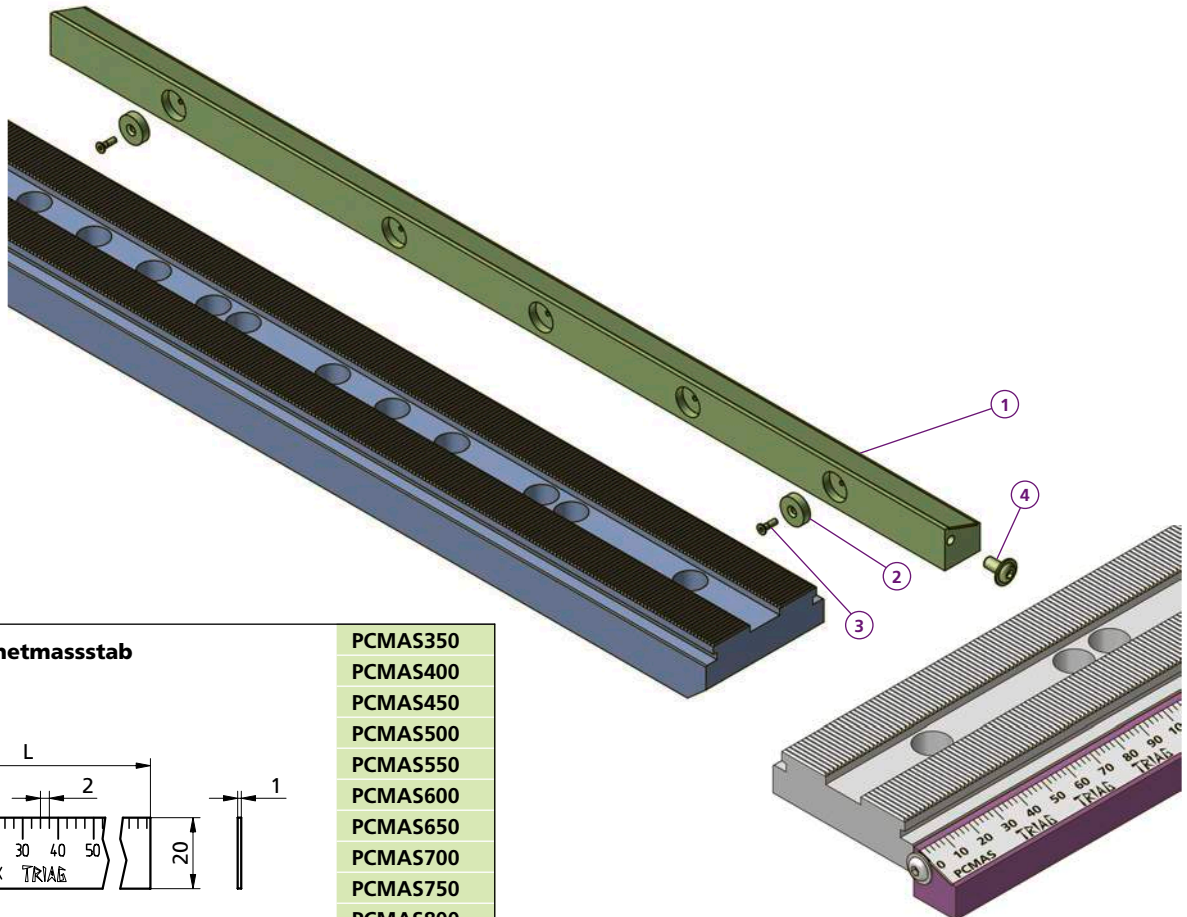
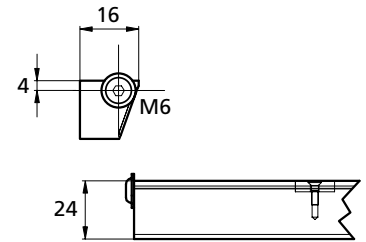
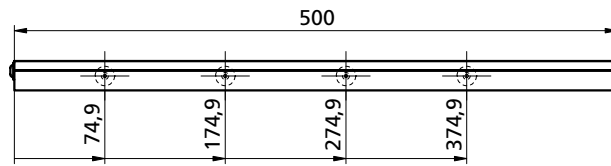

Alu - Magnetmasstab
Alu scale

- PCMAS350
- PCMAS400
- PCMAS450
- PCMAS500
- PCMAS550
- PCMAS600
- PCMAS650
- PCMAS700
- PCMAS750
- PCMAS800

Bestellbeispiel / Ordering example : **PCMAS800ML**

Separat bestellen / Order separately

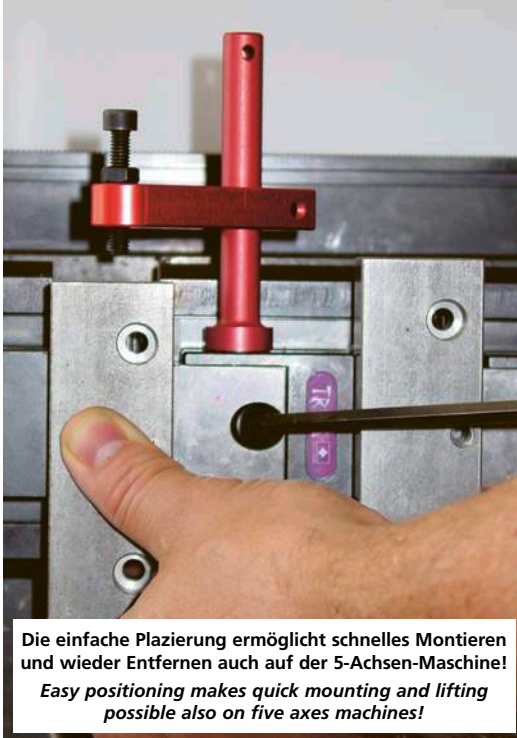

Die einfache Platzierung ermöglicht schnelles Montieren und wieder Entfernen auch auf der 5-Achsen-Maschine!
Easy positioning makes quick mounting and lifting possible also on five axes machines!

Die 3 Sicherheitsstufen:

Durch seine rote Farbe ist der Anschlag besser sichtbar, was das Risiko vermindert, dass er in der Maschine vergessen wird.

Die Bohrung dient zum Befestigen einer Schnur am Handgelenk oder ausserhalb der Maschine.

Dank dem Magnet ist der Anschlag auf allen magnetischen Materialien auf minimalem Platz einsetzbar, bei Kollision wird er weggedrückt. Es entstehen so keine teuren Werkzeugbrüche oder Maschinendefekte.

The 3 safety levels:

Because of its red color, the buffer is better visible. So the risk of forgetting the device in the machine is diminished.

The drilling serves to fasten a cord around the wrist or outside the machine.

Its magnet makes the buffer applicable on all magnetic materials on minimum space, in case of collision it gets pressed away, so there won't be any expensive breaking of tools or machines.

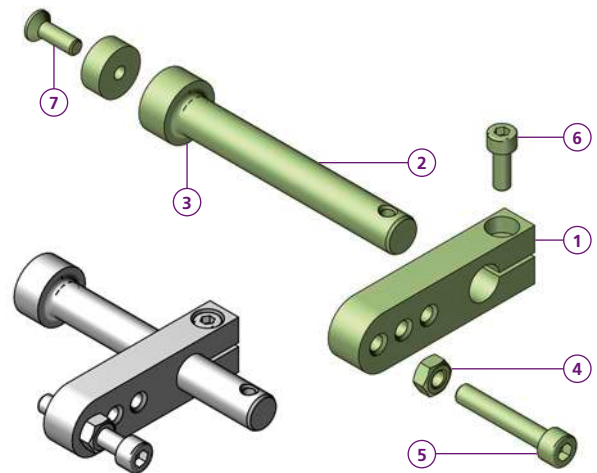
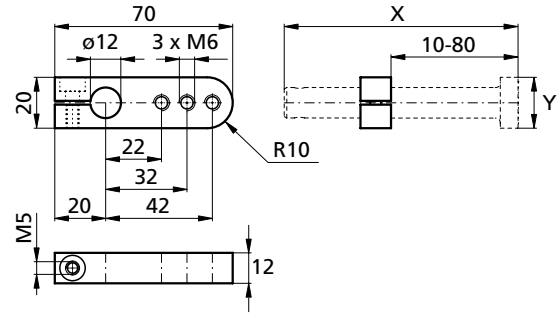

Haltekraft / Holding force

45N = 4,5daN (~4,5 kg)

FAUM2070

- 1 1x FA2070
 - 2 1x FAD2092
 - 3 2x MG1645
 - 4 2x M6ISO4032
 - 5 1x M6X35ISO4762
 - 6 1x M5X14ISO4762
 - 7 1x M3X8ISO10642
- X = 92
 Y = $\varnothing 20$
 kg ~0,084

Haltekraft / Holding force

80N = 8daN (~8 kg)

FAUM2070S

- 1 1x FA2070
 - 2 1x FAD2092S
 - 3 1x MG2570
 - 4 1x M6ISO4032
 - 5 1x M6X35ISO4762
 - 6 1x M5X14ISO4762
 - 7 1x M5X16ISO10642
- X = 95
 Y = $\varnothing 25$
 kg ~0,1

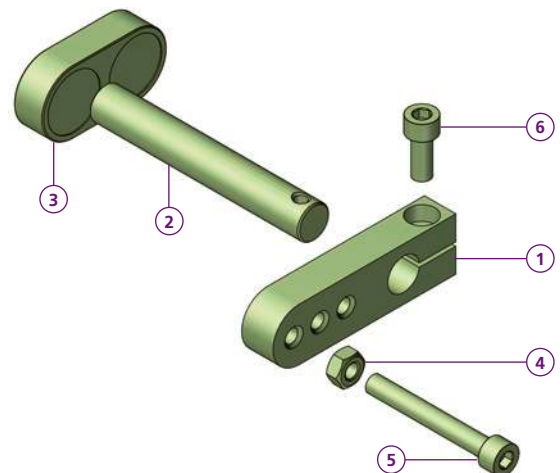
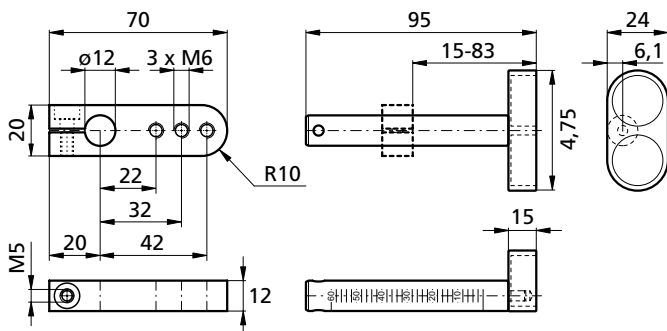

Haltekraft / Holding force

120N = 12daN (~12 kg)

FAUM2070US

- 1 1x FA2070
 - 2 1x FAD1280
 - 3 1x FUSSUS
 - 4 1x M6ISO4032
 - 5 1x M6X35ISO4762
 - 6 1x M5X14ISO4762
- kg ~0,146

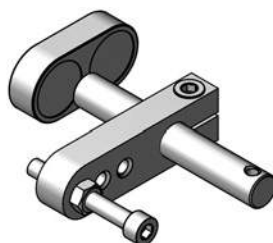

Bestellbeispiel Ordering example : FAUM2070US

Fräsanschlag / Milling buffer

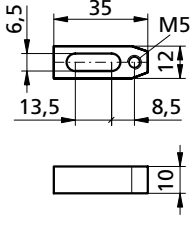
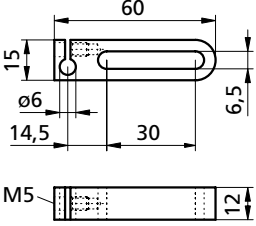
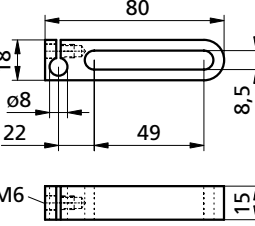
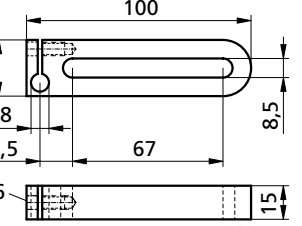
| | | | |
|---|--|--|--|
|  <p>FA1240</p> <p>1x M6X18ISO4762 1x M5X12ISO4762</p> <p>kg ~0,024</p> |  <p>FA1260</p> <p>1x M6X20ISO4762 1x M5X12ISO4762</p> <p>kg ~0,07</p> |  <p>FA1280</p> <p>1x M8X25ISO4762 1x M6X12ISO4762</p> <p>kg ~0,014</p> |  <p>FA12100</p> <p>1x M8X25ISO4762 1x M6X16ISO4762</p> <p>kg ~0,022</p> |
|---|--|--|--|

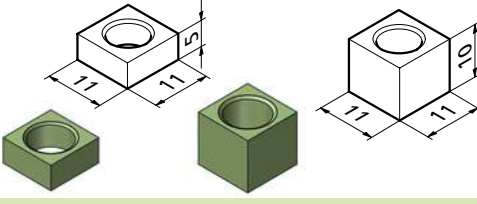
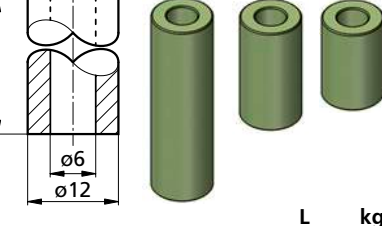
| <p>Distanzbüchse zu Fräsanschlag Spacers for workpiece stop</p>  <p>CCD005 CCD010</p> | <p>Positionierstift (spreizbar) Locating pin (expandable)</p>  <p>CCBX0802</p> <table border="1"> <thead> <tr> <th>L</th> <th>kg</th> </tr> </thead> <tbody> <tr> <td>FAD12018</td> <td>18 ~0,012</td> </tr> <tr> <td>FAD12023</td> <td>23 ~0,016</td> </tr> <tr> <td>FAD12040</td> <td>40 ~0,026</td> </tr> </tbody> </table> | L | kg | FAD12018 | 18 ~0,012 | FAD12023 | 23 ~0,016 | FAD12040 | 40 ~0,026 |
|---|--|---|----|----------|-----------|----------|-----------|----------|-----------|
| L | kg | | | | | | | | |
| FAD12018 | 18 ~0,012 | | | | | | | | |
| FAD12023 | 23 ~0,016 | | | | | | | | |
| FAD12040 | 40 ~0,026 | | | | | | | | |

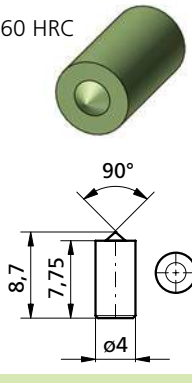
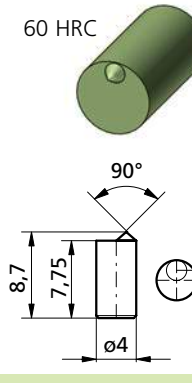
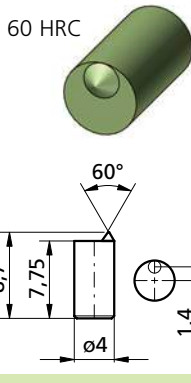
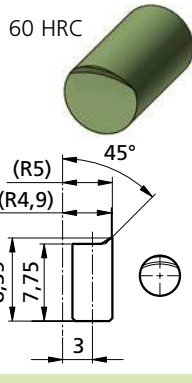
| | | | |
|--|---|---|--|
| <p>60 HRC</p>  <p>DS0402-90°</p> | <p>60 HRC</p>  <p>DSE0402-60°</p> | <p>60 HRC</p>  <p>DSE0402-90°</p> | <p>60 HRC</p>  <p>DSE0402-BS</p> <div style="border: 1px solid black; padding: 5px;"> <p>Einbauanleitung Installation guide</p> <p>Bohrung vorbereiten Preparation of drill-hole</p> <p>Einkleben mit / Glue with Loctite 641</p> </div> |
|--|---|---|--|

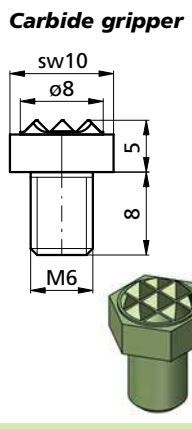
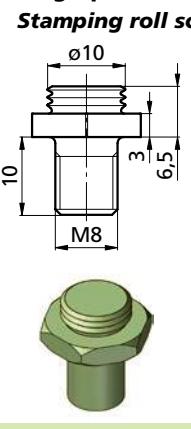
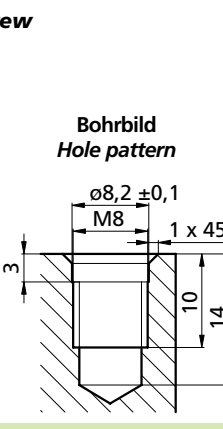
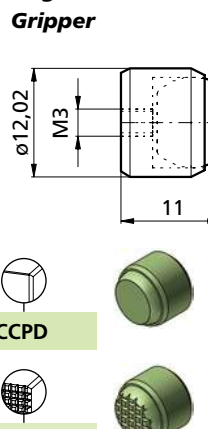
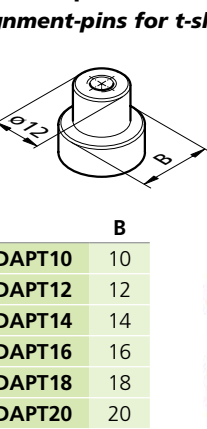
| <p>Hartmetalldruckstück Carbide gripper</p>  <p>CCHMR</p> | <p>Prägespannschraube Stamping roll screw</p>  <p>PRG1003M8</p> <p>Bohrbild Hole pattern</p>  | <p>Kugeldruckstück Gripper</p>  <p>CCPD</p> <p>CCPDR</p> | <p>Ausrichtzapfen für T-Nuten Alignment-pins for t-slots</p>  <table border="1"> <thead> <tr> <th>B</th> </tr> </thead> <tbody> <tr> <td>TWADAPT10</td> </tr> <tr> <td>TWADAPT12</td> </tr> <tr> <td>TWADAPT14</td> </tr> <tr> <td>TWADAPT16</td> </tr> <tr> <td>TWADAPT18</td> </tr> <tr> <td>TWADAPT20</td> </tr> <tr> <td>TWADAPT22</td> </tr> </tbody> </table> | B | TWADAPT10 | TWADAPT12 | TWADAPT14 | TWADAPT16 | TWADAPT18 | TWADAPT20 | TWADAPT22 |
|---|---|---|---|---|-----------|-----------|-----------|-----------|-----------|-----------|-----------|
| B | | | | | | | | | | | |
| TWADAPT10 | | | | | | | | | | | |
| TWADAPT12 | | | | | | | | | | | |
| TWADAPT14 | | | | | | | | | | | |
| TWADAPT16 | | | | | | | | | | | |
| TWADAPT18 | | | | | | | | | | | |
| TWADAPT20 | | | | | | | | | | | |
| TWADAPT22 | | | | | | | | | | | |

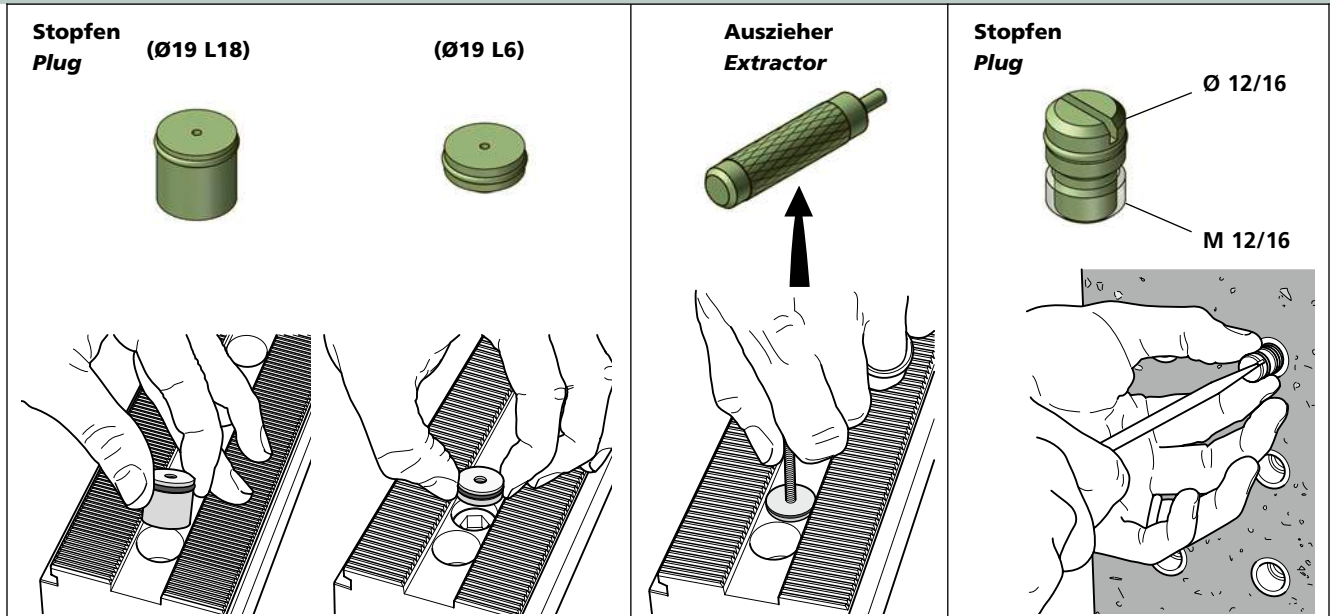

PCPF16L18 PCPF16L6 PCAZM3 CCPF12ALU / CCPF16ALU

Spannschrauben (Nitriert)
Clamping screw (Nitrided)

für/for kg

| | | |
|-----------------|-----|--------|
| M8x20ISO4762NQ | B60 | ~0,012 |
| M10x25ISO4762NQ | B80 | ~0,024 |

Passschrauben / Fitting screw

M5 / M6 / M12 / M16

Reduktionshülsen für Rasterplatte
Reduction sleeve for grid plate

| | | |
|--------------|--------------|---------|
| RD18M1612M12 | RD16M1612M12 | RD16M12 |
|--------------|--------------|---------|

| | D | G | L | B | K | sw | Nm | kg |
|------------|-------|-----|----|----|------|----|-----|--------|
| MS50 | 5 f7 | M5 | 17 | 9 | 5 | 4 | 4,5 | ~0,004 |
| MS60 | 6 f7 | M6 | 17 | 9 | 6 | 5 | 8 | ~0,006 |
| TWPAS1227 | 12g7 | M12 | 27 | 14 | 12 | 10 | 60 | ~0,038 |
| TWPAS1232 | 12g7 | M12 | 32 | 19 | 12 | 10 | 60 | ~0,042 |
| TWPAS1240 | 12g7 | M12 | 40 | 20 | 12 | 10 | 60 | ~0,048 |
| TWPAS1250 | 12g7 | M12 | 50 | 30 | 12 | 10 | 60 | ~0,058 |
| TWPAS16055 | 16 f7 | M16 | 55 | 30 | 15,8 | 14 | 150 | ~0,120 |

T-Nuten Steine / T-slot nuts

| d | α | kg |
|---------------|---|--------|
| SM1135 M06X08 | | ~0,012 |
| SM1135 M06X10 | | ~0,012 |
| SM1135 M08X10 | | ~0,012 |
| SM1135 M08X12 | | ~0,022 |
| SM1135 M08X14 | | ~0,04 |
| SM1135 M10X12 | | ~0,02 |
| SM1135 M10X14 | | ~0,038 |
| SM1135 M12X14 | | ~0,045 |
| SM1135 M12X16 | | ~0,045 |
| SM1135 M12X18 | | ~0,078 |
| SM1135 M12X20 | | ~0,13 |
| SM1135 M14X16 | | ~0,188 |
| SM1135 M14X18 | | ~0,188 |
| SM1135 M16X18 | | ~0,068 |
| SM1135 M16X20 | | ~0,11 |
| SM1135 M18X20 | | ~0,11 |
| SM1135 M18X22 | | ~0,15 |
| SM1135 M18X22 | | ~0,15 |
| SM1135 M20X22 | | ~0,15 |
| SM1135 M20X24 | | ~0,23 |
| SM1135 M24X28 | | ~0,31 |

Bohrbüchsen
Position case

| | L | D | d |
|--------------|----|------|------|
| CCBUE121812 | 12 | 18,0 | 12,0 |
| CCBUE1218512 | 12 | 18,5 | 12,0 |
| CCBUE121912 | 12 | 19,0 | 12,0 |
| CCBUE162616 | 16 | 26,0 | 16,0 |

Nutensteine, flach
Low slot tenons

Einsatzgehärtet, brüniert, geschliffen
Case-hardened, blackened, ground

| | b | H | L | d1 | d2 | t | inkl. Schrauben incl. screws | kg |
|-----------|----|----|-----|----|-----|---|---------------------------------|--------|
| SM1136-12 | 8 | 20 | 5,5 | 10 | 5,3 | | M5x12 | ~0,019 |
| SM1136-14 | | | | | | | M6x16 | ~0,021 |
| SM1136-16 | | | | | | | M6x16 | ~0,026 |
| SM1136-18 | 10 | 22 | 6,6 | 11 | 6,3 | | M6x16 | ~0,03 |
| SM1136-20 | | | | | | | M6x16 | ~0,034 |

Nutensteine, fest
Fixed slot tenons

Einsatzgehärtet, brüniert, geschliffen
Case-hardened, blackened, ground

| | H | L | b | Nutenmass slot size | inkl. Schrauben incl. screws | kg |
|--------|----|----|----|------------------------|------------------------------------|--------|
| NT2012 | | 22 | 12 | 20 | M6x10 | ~0,022 |
| NT2014 | | | 14 | 20 | M6x10 | ~0,026 |
| NT2016 | 10 | 25 | 16 | 20 | M6x10 | ~0,028 |
| NT2018 | | | 18 | 20 | M6x10 | ~0,03 |
| NT2022 | | 12 | 32 | 20 | M6x12 | ~0,05 |
| NT2024 | | | 24 | 20 | M6x12 | ~0,055 |

Pneumatikschrauber Set
Pneumatic screwdrivers set

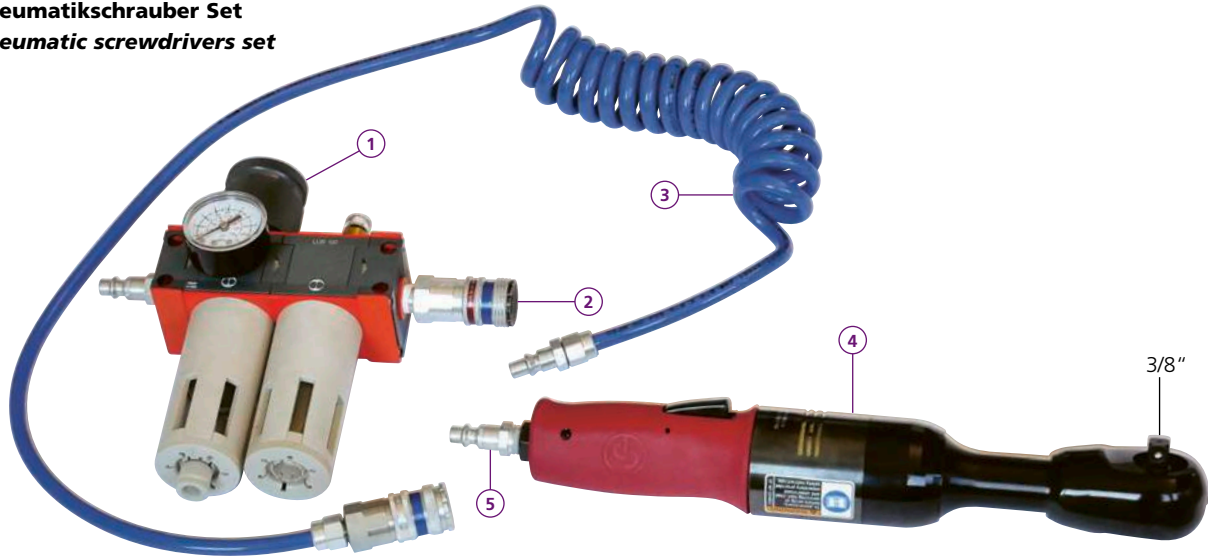

RP9431SET

- ① 1x P1H-200-M3QG
 - ② 1x 103002152 (SERIE 300) 1/4"
 - ③ 1x 199589977 (5 x 8 mm, 300, 2 m)
 - ④ 1x RP9431
 - ⑤ 2x 103105152 1/4"
- kg ~1,5

| Drehmomenttabelle / Torque table | Druck / Compression (bar) | Nm |
|----------------------------------|---------------------------|----|
| | 6 | 50 |
| Schlauchdurchmesser 8 mm | 5,5 | 45 |
| Luftverbrauch 2,5 L Sek | 5 | 40 |
| | 4,5 | 35 |
| Hose diameters 8 mm | 4 | 30 |
| Air consumption 2,5 L sec | 3,5 | 25 |
| | 3 | 20 |

mit Feder gehalten, nicht magnetisch
 spring locked, not magnetic



mit Feder gehalten, nicht magnetisch
 spring locked, not magnetic



siehe Video
 see video

Triag Bit

Triag Bitburr

Luftpistolen Gummiadapter
Air gun rubber adapter



ARA14

Magnethalter
Magnetic holder

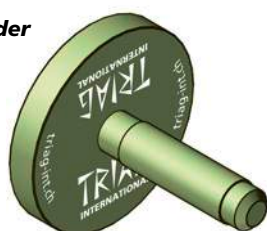

Smiley

Einsätze zu Bitburr
Inserts for Bitburr



TC10



BitF63 $\varnothing 6,3-90^\circ$

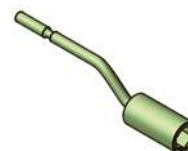

BIT-KH



BitF104 $\varnothing 10,4-90^\circ$



BIT-BF



BitF165 $\varnothing 16,5-90^\circ$

Einsatz für Triva Bit
Insert for Triva Bit



BitT

Bestellbeispiel / Ordering example: **RP9431SET**

Drehmomentschlüssel
Torque wrench





SL3 20-200 Nm (1/2")

Steckschlüsseleinsatz
Socket wrench insert

Torx  Sechskanteinsatz *Hexagon insert* 

| | | |
|-----------------|-----------|--------------------------|
| NUSS3/8"TX30E14 | für / for | MCZ, ZSX, ZSM, ZSB, PCZ |
| NUSS1/4"4.5MM | 4,5 mm | für / for MCZ40L30, |
| NUSS1/4"5.5MM | 5,5 mm | UB5AXSET3, PCZ80L40PRG62 |

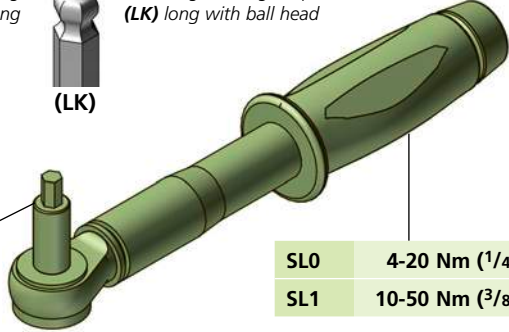
Sechskantstifteinsatz
Hexagonal socket wrench

(L) lang  (LK) lang mit Kugelkopf 
(L) long (LK) long with ball head

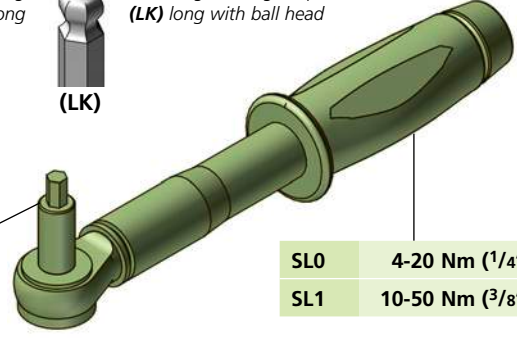

SL0 4-20 Nm (1/4")
SL1 10-50 Nm (3/8")

| | | | |
|---------------|------|----------------|-------|
| NUSS1/4"4MM | 4 mm | NUSS3/8"6MM | |
| NUSS1/4"5MM | 5 mm | NUSS3/8"6MML | 6 mm |
| NUSS1/4"6MM | 6 mm | NUSS3/8"6MMLK | |
| NUSS1/4"8MM | 8 mm | NUSS3/8"8MM | |
| | | NUSS3/8"8MML | 8 mm |
| | | NUSS3/8"8MMLK | |
| NUSS3/8"5MM | | NUSS3/8"10MM | |
| NUSS3/8"5MML | 5 mm | NUSS3/8"10MML | 10 mm |
| NUSS3/8"5MMLK | | NUSS3/8"10MMLK | |

Spannschlüssel
Clamping wrench



| | |
|----------|-------|
| 02613160 | 4 mm |
| 02613164 | 5 mm |
| 02613168 | 6 mm |
| 02613172 | 8 mm |
| 02613176 | 10 mm |

Langer Spannschlüssel
Long clamping wrench

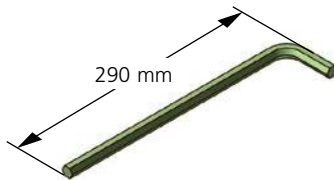

290 mm

| | |
|-------|------------|
| ISL10 | sw = 10 mm |
| ISL14 | sw = 14 mm |

Sechskantstifteinsatz
Hexagonal socket wrench



| | |
|--------------|---------------|
| NUSS1/2"8MM | NUSS1/2"14MML |
| NUSS1/2"10MM | |
| NUSS1/2"14MM | |



AD-BIT-1/4-1/4



AD-BIT-1/4-3/8

Messingdrahtbürste
Brass wire brush

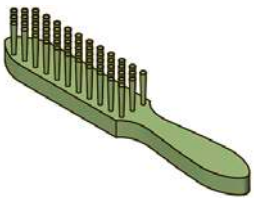

PCMB4



Triag Ei

3D Mess-Gelenkstativ
Articulated indicator holders



Aktionsradius / Operating radius

| | |
|-----------|--------|
| MGMS08130 | 130 mm |
| MGSS08130 | 130 mm |
| MGMS08280 | 280 mm |

Index

- 5AXMCZ100-45-3 136
 5AXMCZ100-45-3H 136
 5AXMCZ100-45-4 134
 5AXMCZ100-45-4H 135
 5AXMCZ100-45-6 136
 5AXMCZ100-45-8 135
 5AXMCZ100-45-12 135
 5AXMCZ100-90-4 134
 5AXZ5X35-3 154
 0130001 324
 0130002 324
 243834.0083300 290
 243834.0103300 290
 243834.0123300 290
 0500205 326
 0520000 324
 0700100 314, 315, 316, 317, 318, 324
 0700102 314, 315, 316, 317, 324
 0700200 324
 0802000-SET 322
 0910000 323, 326
 0910001 314, 315, 316, 317, 318, 323
 0910080 323
 0920000 314, 315, 316, 317, 318, 319, 323, 326
 0930000 323
 0940200-SET 323
 0940300-SET 323
 0940800 323
 0940800-SET 323
 0941000 321, 323
 0941010 324
 1110100 314, 315, 316, 317, 321, 324
 1110100S 324
 1110100SP 324
 1111003 314, 315, 316, 317, 318, 319, 323, 326
 1120100 314, 315, 316, 317, 318, 319, 321, 324
 1120100M 324
 1130000 324
 02613160 340
 02613164 340
 02613168 340
 02613172 340
 02613176 340
 10100024 323
- A**
 AA5X115-50 228
 AA5X125-50 229
 AA5X125-50VB 231
 AA5X150-50 230
 AAND115-50 228
 AAND125-50 229
 AAND150-50 230
 AC1505520W 233
 AC1505540W 233
 ACB4050400 222
 ACB4050450 222
 ACB4050500 222
 ACB4050550 222
 ACB4050600 222
 ACB4050650 222
 ACB4050700 222
 ACB4050750 222
 ACB4050800 222
 ACBS1646 233
- ACD005 223, 224, 225, 227
 ACES6540 232
 ACES10040H25W 232
 ACES10240H07 232
 ACGGB103048 227, 231
 ACPB103048 227, 231
 ACU21124 232
 ACU36124 232
 ACU41124 232
 ACU46124 232
 ACUH21-124 233
 ACWB103048 227, 231
 ACZ56540 232
 ADAPT6-12 317, 324
 AD-BIT-1/4-1/4 340
 AD-BIT-1/4-3/8 340
 ARA14 339
 AS1F150N50-80 226
 AS1R150N50-80 226
 AS2F115N50-80 223
 AS2F125N50-80 224
 AS2F150N50-80 225
 AS2R115N50-80 223
 AS2R125N50-80 224
 AS2R150N50-80 225
 AS2X125L50-105 227
 AS25X115N50-80 223
 AS25X125L50-105 227
 AS25X125N50-80 224
 AS25X150N50-80 225
 AS35 47, 146
 AS60 47, 146
 AS80 47, 146
- B**
 B01 182, 183, 184, 185
 B02 182, 183, 184, 185
 B03 182, 183, 184, 185
 B04 182, 183, 184, 185
 B05 182, 183, 184, 185
 B05R 182, 183, 184, 185
 B07 178, 179, 180
 B08 178, 179, 180
 B09 178, 179, 180
 B09+2 178, 179, 180
 B09+5 178, 179, 180
 B13 61, 71, 181
 B14 61, 71, 181
 B15 61, 71, 181
 B16 61, 71, 181
 B20 60, 186
 B21 60, 186
 B22 60, 186
 B26 62, 187
 B27 62, 187
 B28 62, 187
 B30 197
 B31 197
 B32 197
 B33 197
 B36 190
 B37 190
 B38 190
 B45 63, 72
 B46 63, 72
 B47 63, 72
 B47HM 63, 72
 B51 198, 201
 B52 198, 201
 B53 198, 201
 B54 198, 201
 B55 198, 201
 B58 64, 73, 188, 189, 191, 192, 194, 195
 B60 64, 73, 188, 189, 191, 192, 194, 195, 338
 B61 64, 73, 188, 189, 191, 192, 194, 195
 B62 64, 73, 188, 189, 191, 192, 194, 195
 B62HM 64, 73, 188, 189, 191, 192, 194, 195
 B65 64, 73, 188, 189, 191, 192, 194, 195
 B66 64, 73, 188, 189, 191, 192, 194, 195
 B67 64, 73, 188, 189, 191, 192, 194, 195
 B68 64, 73, 188, 189, 191, 192, 194, 195
 B69 64, 73, 188, 192
 B77 64, 73, 188, 189, 191, 192, 194, 195
 B78 198, 201
 B79F 64, 73, 188, 189, 191, 192, 194, 195
 B79R 64, 73, 188, 189, 191, 192, 194, 195
 B80 65, 66, 67, 223, 224, 225, 226, 226
 B80N 65, 66, 67, 223, 224, 225, 226
 B81 65, 66, 67, 223, 224, 225, 226
 B82 65, 66, 67, 223, 224, 225, 226
 B82HM 65, 66, 67, 223, 224, 225, 226
 B82L33 65, 66, 67, 223, 224, 225, 226
 B83 65, 66, 67, 223, 224, 225, 226
 B84 65, 66, 67, 223, 224, 225, 226
 B89F 65, 66, 67, 223, 224, 225, 226
 B89R 65, 66, 67, 223, 224, 225, 226
 B90 68
 B90F78 69
 B90R78 69
 B90W78 69
 B91 68
 B92 68
 B93 68
 B94 68
 B95 70, 193
 B96 70, 193
 B97 70, 193
 B98 70, 193
 B99 70, 193
 B105 77, 79, 80, 81, 85, 200, 227
 B105-15 85
 B105H20 82
 B105P 85
 B106 85
 B106H20 82
 B106P 85
 B107 85
 B107H20 82
 B107P 85
 B108 85
 B108P 85
 B110 79, 84
 B110H20 82
 B110P 84
 B110P-PRGM8 84
 B111 84
 B111H20 82
 B111P 84
 B112 84
 B112E 84
 B112EP 84
 B112H20 82
 B112HG 84
 B112P 84
 B113 84
 B113P 84
 B115 74, 85, 199
 B115P 85
 B116P 85
 B117P 84
 B120 75, 84
 B120P 80, 84
 B122P 78
 B123P 76
 B130H20P 83
 B131H20P 83
 B132H20P 83
 B140 85
 B140P 85
 B141 85
 B141P 85
 B150 196
 B151 196
 B170 128
 B172 128, 130
 B172-MB 130
 B173-26 129
 B173-45 129
 B173-64 129
 B173-83 129
 B173-102 129
 B173-MB 130
 B173SET 129
 B175-26 128
 B175-45 128
 B175-64 128
 B175-83 128
 B175-102 128
 B175-121 128, 135
 B175-MB 130
 B175SET 128
 B176-80 129
 B190-13 116
 B190-22 116
 B190-31 116
 B190W6-40 117
 B190W10-40 117
 B190W20-40 117
 B190W30-40 117
 B210-62 123, 124
 B212W11-60 123, 124
 B212W20-60 123, 124
 B222 156
 B240UPRG 149
 B242W50-100 149
 B310 105
 B311 105
 B312 105
 B313 105
 BIT-BF 339
 BitF63 339
 BitF104 339
 BitF165 339

Index

- PCU29124 112, 232
PCU31018 112
PCU31025 112
PCU31033 112
PCU31042 112
PCU31047 112
PCU31057 112
PCU31060 112
PCU31067 112
PCU31077 112
PCU31093 112, 232
PCU31093B10 112
PCU31124 112, 232
PCU34018 112
PCU34025 112
PCU34033 112
PCU34042 112
PCU34047 112
PCU34077 112
PCU34093 112, 232
PCU34093B10 112
PCU34124 112, 232
PCU39018 112
PCU39025 112
PCU39033 112
PCU39042 112
PCU39047 112
PCU39077 112
PCU39093 112, 232
PCU39093B10 112
PCU39093B10-W 112
PCU39124 112, 232
PCU44018 112
PCU44025 112
PCU44033 112
PCU44042 112
PCU44047 112
PCU44077 112
PCU44093 112, 232
PCU44093B10 112
PCU44093B10-W 112
PCU44124 112, 232
PCU46033 112
PCU46042 112
PCU46047 112
PCU46093 112, 232
PCU46093B10 112
PCU46093B10-W 112
PCU46124 112
PCU46518 112
PCU46525 112
PCU46533 112
PCU47042 112
PCU47093 112
PCUB60-70-130 51
PCUB60-130 48
PCUB100-200 48
PCUB100-300 48
PCUB115-200-R25 50
PCUB115-300-R25 50
PCUH2594 112
PCUM1409308 111
PCUM2009308 111
PCUM2409308 111
PCUM2909308 111
PCUM3109308 111
PCUM3409308 111
PCUM3909308 111
PCUM4409308 111
PCUM4609308 111
PCUSR14 200
PCWB252594 73
PCWB262694 73
PCZ80L40PRG62 123
PCZ100L50 126
PCZB7021PRF 152
PCZB7023PRG 152
PCZB8050UPRG 150, 152
PCZB8060R34 152
PCZB8060R40ALU 152
PCZB10060R50 152
PCZB10060R50ST 152
PCZB12060R34 152
PCZS2439-ID-SET 126, 127
PCZS2439L 126, 127
PCZS2439R 126, 127
PF-SET 85
PR94-39-50 94
PR94-39-50SET 94
PR94-49 94
PR94-49SET 94, 143
PR125-49 94
PR125-49ALU 94
PR125-49SET 94
PR125-49SETALU 94
PR150-49 94
PR150-49SET 94
PRG1003M8 129, 152, 337
PRS50L78ST 96
PRS70L78ST 96
PS1F19N49-20 60
PS1F20L35BV1 101
PS1F20L35BV1NS 101
PS1F25N44-13 61
PS1F26N49-26 62
PS1F34N49-45 63
PS1F43N49-60 51, 64
PS1F43N62-60 64
PS1F48L34-105 76
PS1F48L49-105 79
PS1F48N34-80 65
PS1F48N49-80 66
PS1F58N34-80 65
PS1F68N34-80 65
PS1F78L34-105 77
PS1F78L49-105 77
PS1F78N34-80 67
PS1F78N49-80 67
PS1F78N49-90 69
PS1F94L34-105 81
PS1F94L49-105 81
PS1F94N34-80 67
PS1F94N34-90 68
PS1F94N49-90 68
PS1F125N49-95 70
PS1F-KLD1 100
PS1F-KLD1NS 100
PS1P48L34-105 74
PS1P48L49-105 74
PS1P94L34-105 75
PS1P94L49-105 75
PS1P694L34-105 75
PS1PF48L34-105 74
PS1PF48L49-105 74
PS1PF94L34-105 75
PS1PF94L49-105 75
PS1PV48L34-105 76
PS1PV94L34-105 78
PS1PV94L49-105 78
PS1R19N49-20 60
PS1R25N44-13 61
PS1R26N49-26 62
PS1R34N49-45 63
PS1R43N49-60 64
PS1R43N62-60 64
PS1R48L34-105 76, 77
PS1R48L49-105 79
PS1R48L49-105H20 82
PS1R48N34-80 65
PS1R48N49-80 66
PS1R48N75-80 66
PS1R58N34-80 65
PS1R58N49-80 65
PS1R68N34-80 65
PS1R78L34-105 77
PS1R78L49-105 77
PS1R78N34-80 67
PS1R78N49-80 67
PS1R78N49-90 69
PS1R94L34-105 81
PS1R94L49-105 81
PS1R94L49-105H20 82
PS1R94N34-80 67
PS1R94N34-90 68
PS1R94N49-90 68
PS1R125L49-105H20 83
PS1R125N49-95 70
PS1X50L78ST 96
PS1X50N62-ER32 99
PS1X50N70H-ER32-NS 99
PS1X50N100-ER32 99
PS1X63N100-ER40 99
PS1X68N80-W20 99
PS1X70L78ST 96
PS1X80L31-VAC 319, 321
PS1X100-65ER-036345 104
PS1X150L60-250MAG11 102
PS1X150L60-VAC 103, 318, 321
PS2F61N34-45 72
PS2G94N44-13 71
PS2R61N34-45 72
PS2X94N49-60 73
PS3X80L75BSET 98
PS3X100L82BSET 98
PS3X125L87BSET 98
PS5X19N49-20 60
PS5X26N49-26 62
PS5X34N49-45 63
PS5X43N49-60 64
PS5X48L34-105 80
PS5X48L49-105 79
PS5X48N49-80 66
PS5X94L49-105 81
PS5X94N49-90 68
PS5X125N49-95 70
PSH1X94L49-310 105
PT-F61-25X30 93
PT-F61-25X50 93
PT-F61-25X60 93
PT-F80-30X30NS 93
PT-F80-30X60 93
PT-F80-30X60NS 93
PT-F132-34RD 94
PT-F132-34RDSET 94
PTX80-30 98
PTX100-29 104
PTX100-30 98
PTX125-29 98
PTX160-57S 95
PTX160-77S 95
PTX-MCZ40L30 101
- Q
QSG1/4-8 319, 323
QSL-G1/4-8 323
- QST-G1/4-8 323
- R
RD16M12 338
RD16M1612M12 338
RD18M1612M12 338
RP9431SET 339
RPD504-R50 274
RPQ50504-R50 274
- S
SET18ZSP40L38-2 156
SET18ZSP125L85-1 157
SET18ZSP125L110-2 158
SFED6W90 196
SL0 340
SL1 340
SL3 340
SM1135M6X8 322, 338
SM1135M06X10 338
SM1135M08X10 338
SM1135M08X12 338
SM1135M08X14 338
SM1135M10X12 338
SM1135M10X14 338
SM1135M12X14 338
SM1135M12X16 338
SM1135M12X18 338
SM1135M12X20 338
SM1135M12X22 338
SM1135M14X16 338
SM1135M14X18 338
SM1135M16X18 338
SM1135M16X20 338
SM1135M18X20 338
SM1135M18X22 338
SM1135M20X22 338
SM1135M20X24 338
SM1135M24X28 338
SM1136-12 338
SM1136-14 338
SM1136-16 338
SM1136-18 338
SM1136-20 43, 338
Smiley 339
SMK24-24-42OPP200 272
SMK30-17-42OPP200 272
SMK301850R50 253
SMK301855R50 253
SMK301860R50 253
SMK301865R50 253
SMK301870R50 253
SMK301875R50 253
SMK351865R50 255
SMK351870R50 255
SMK351875R50 255
SMK351880R50 255
SMK351885R50 255
SMK351890R50 255
SMK351895R50 255
SMUB2373H220 276
SMUB3373H220 276
- T
TB150091 146
TB150092 146
TB160379 301
TB170051 142
TC10 339
TK150057 174
TN100668 326, 327
TN100682 323

Index

Triag Bit 339
Triag Bitburr 339
Triag Ei 340
Triva Bit 324
TS150487 323
TWADAPT10 337
TWADAPT12 337
TWADAPT14 337
TWADAPT16 337
TWADAPT18 337
TWADAPT20 337
TWADAPT22 337
TWPAS1227 338
TWPAS1232 195, 338
TWPAS1240 46, 50, 154, 179,
338
TWPAS1250 338
TWPAS16055 338

U

UA2-260 321, 322
UA3-360 321, 322
UA3-560 321, 322
UA3-660 321, 322
UA0770 321, 322
UA182540 318, 321, 322
UB1-OIL 325
UB5AXMCZ40-35SET4 118
UB5AXMCZ40-35SET8 118
UB5AXMCZ40-45SET8 119
UB5AXMCZ40-45SET8-ER 119
UB5AXMCZ4035SET4 118
UB5AXMCZ4035SET8 118
UB5AXMCZ4045SET4 119
UB5AXMCZ4045SET4-ER 119
UB5AXMCZ4045SET8-OPBM
286
UB5AXMCZ4045SET8-OPMB
119
UB5AXSET18-3 122
UBA106110250 321, 325

UBA106230300 321, 325
UBA118230600 325
UBA306400250 325
UBA318400550 321, 325
UBS5045 326
UBT40 325
UF15030050R50 317, 321
UF20030050R50 316, 321
UF30060050R50 315, 321
UF50050050R50 314, 321
UP15030040R50G06 317, 320,
321
UP15030040R50G13 317, 321
UP20030040R50G06 316, 320,
321
UP20030040R50G13 316, 321
UP30060040R50G06 315, 320,
321
UP30060040R50G13 315, 321
UP50050040R50G06 314, 320,
321
UP50050040R50G13 314, 321
UPB1JN 321, 327
UPB2JN 321, 327
US150300 317
UT1003040 318, 321, 322
UZA4012G06 321, 322
UZA5015G13 321, 322
UZV16301/4SET 323
UZV16301/4SET-90° 323
UZV16301/4SET-T 323

V

VA168-20PRG 199
VFP08040L90 (Ø 4 mm) 324
VFP10065L100 (Ø 6,5 mm) 324
VS1F19N35-20 186
VS1F41L30-51 198
VS1F41N30-60 189
VS1F48L50-105 200
VS1F80L30-51 201

VS1F80N30-36 190
VS1F80N30-60 191
VS1F125N49-95 193
VS1P48L50-105 200
VS1R19N35-20 186
VS1R26L35-31 197
VS1R26N35-26 187
VS1R38N50-60 188
VS1R41L30-51 198
VS1R41N30-60 189
VS1R80L30-51 201
VS1R80N30-36 190
VS1R80N30-60 191
VS1R80N50-36 190
VS1R80N50-60 192
VS1R125N49-95 193
VS1X59L60H5 203
VS1X59L60K 202
VS1X68L20-105 199
VS2F90N30-60 195
VS2R80N30-60 194

W

WU-18 288
WU-25 288

Z

ZB150786 141
ZB150787 141
ZB150791 150
ZB150792 150
ZB170050 142
ZF211785 286, 287
ZF222333 287
ZK160798M5 129
ZSB140L50 150, 151
ZSB160L50 150, 151
ZSB180L50 150, 151
ZSB200L50 150, 151
ZSM140L50 115, 143, 144
ZSM160L50 143, 144
ZSM170L65GH200PCB 145, 146
ZSM180L50 143, 144
ZSM200L50 139, 143, 144
ZSM300L50 144
ZSMB250L82 147
ZSMB500L112 147
ZSP40L38-2 156
ZSP125L85-1 157, 159
ZSP150L100 160
ZSP200L100 160
ZSP250L100 160
ZSQ160L50UPRG 148
ZSQ180L50UPRG 148
ZSQ200L50UPRG 148
ZSQ160L50UPRG 148
ZSQP180L50UPRG 148
ZSQP200L50UPRG 148
ZSQP300L50UPRG 148
ZSX140L50PRG120 142
ZSX140L50UPRG 141, 283
ZSX140L50UPRG-OPM 286
ZSX160L50PRG120 142
ZSX160L50UPRG 141
ZSX160L50UPRG-OPM 286
ZSX180L50PRG120 142
ZSX180L50UPRG 141
ZSX180L50UPRG-OPM 286
ZSX200L50PRG120 142
ZSX200L50UPRG 141, 154
ZSX200L50UPRG-OPM 286



**Produktion einer Werkstück Familie
Producing a complete workpiece family**

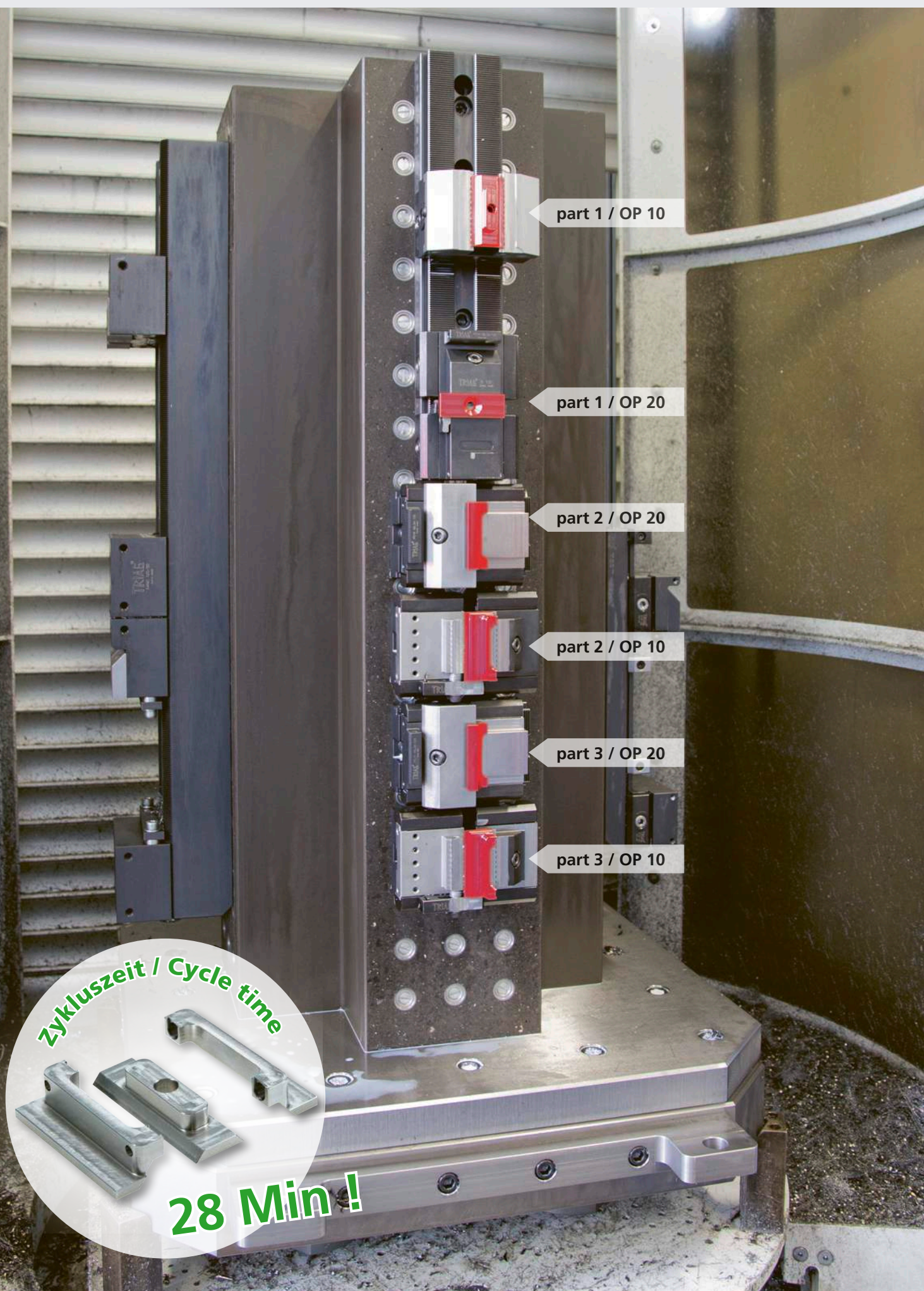

Zykluszeit / Cycle time

28 Min!



powerCLAMP & 5axes

Das schnellstverstellbare Mehrfachspannsystem! Die Positionierung der Spannmodule erfolgt mittels einer Verzahnung auf der Schiene. Befestigung mit nur einer Schraube!

powerCLAMP & 5axes

The quickest multiple workholding system for easy set up! Positioning of the clamping modules by teeth on the base rail. Repositioning by opening only one single screw!



tricENTRO

Kleine bis grosse, sowie modulare Zentrischspanner in verschiedenen Ausführungen.

tricENTRO

Small to big modular self centering vises in different variations.



microCLAMP

Kleinste Module für den Vorrichtungsbau. Sie haben eine grosse Spannkraft (bis 28'000N), der benötigte Abstand zwischen den Werkstücken ist im Optimalfall nur 15 mm.

microCLAMP

Smallest modules for dedicated fixtures. Having a high clamping force (up to 28'000N) the distance between workpieces is only 15 mm in optimum set up.

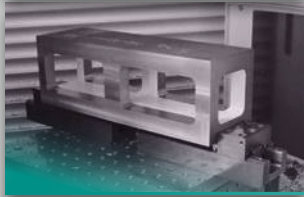

aptoCLAMP & 5axes

Die hohe Spannkraft dieses Systems ermöglicht den Einsatz für schwere Zerspanung.

aptoCLAMP & 5axes

The high clamping force of the aptoCLAMP enables heavy cuts.



tripoxyMINERAL

Spanntürme aus Mineralguss. Die Vibrationsdämpfung ist zehnmals besser als bei Grauguss. Das spezifische Gewicht ist hingegen kleiner als bei Aluminium. Erhältlich in vielen verschiedenen Formen.

tripoxyMINERAL

Tombstones made of composite concrete. Vibration damping effect is ten times better than with cast iron. Specific weight on the other hand is less than aluminium. Available in many different shapes.

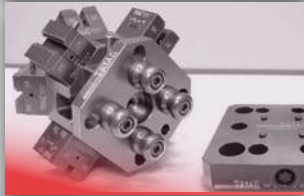

oppSystem & 5axes

Unser Nullpunkt-Palettiersystem ermöglicht ein genaues Positionieren von Mehrfachspannsystemen, Schraubstöcken und Vorrichtungen auf Maschinentischen oder Spanntürmen.

oppSystem & 5axes

Our zero-point palleting system allows exact positioning of multiple workholding systems, vices and dedicated fixtures on machining tables or tombstones.



trivaCLAMP

Vakuumspannsystem: Bestens geeignet für plattenförmige Werkstücke (auch nicht magnetische). Es können sowohl Druckstellen als auch Deformationen an labilen Teilen vermieden werden.

trivaCLAMP

Workholding by vacuum: Suited for plateshaped workpieces (also for non magnetical). Pressure marks as well as deformations on soft parts can be avoided.



triGEL

Unser Gefrierspannsystem. Sehr gut geeignet für unförmige Teile. Es erlaubt mehrseitiges Bearbeiten ohne Neuspannen. Das Haftvermögen ist sehr gross, wobei die Gefrier- und Auftauzeiten sehr gering sind.

triGEL

Workholding by freezing: Well suited for strangely shaped parts. It allows processing from more than one side without unclamping. Holding effects are very strong whereas freezing and defrosting times are very short.

swiss 
MODULAR[®]

Triag International AG

Bösch 84 CH-6331 Hünenberg

☎ +41 41 727 27 77

✉ spannen@triag-int.ch

✉ clamping@triag-int.ch

TRIAG
INTERNATIONAL

swissmodular.com

Official Website

