



MOLDINO

The Edge To Innovation

MMC Hitachi Tool Engineering Europe GmbH

GALLEA

**Circle-Segment Tool Series for
High Efficiency Finishing**

GF1

GP1T

GP1LB

GS4TN



MMC Hitachi Tool Engineering Europe GmbH



GALLEA Series: Maximized Cutting Edge Radii for Big-Pitch Finishing in Die & Mould

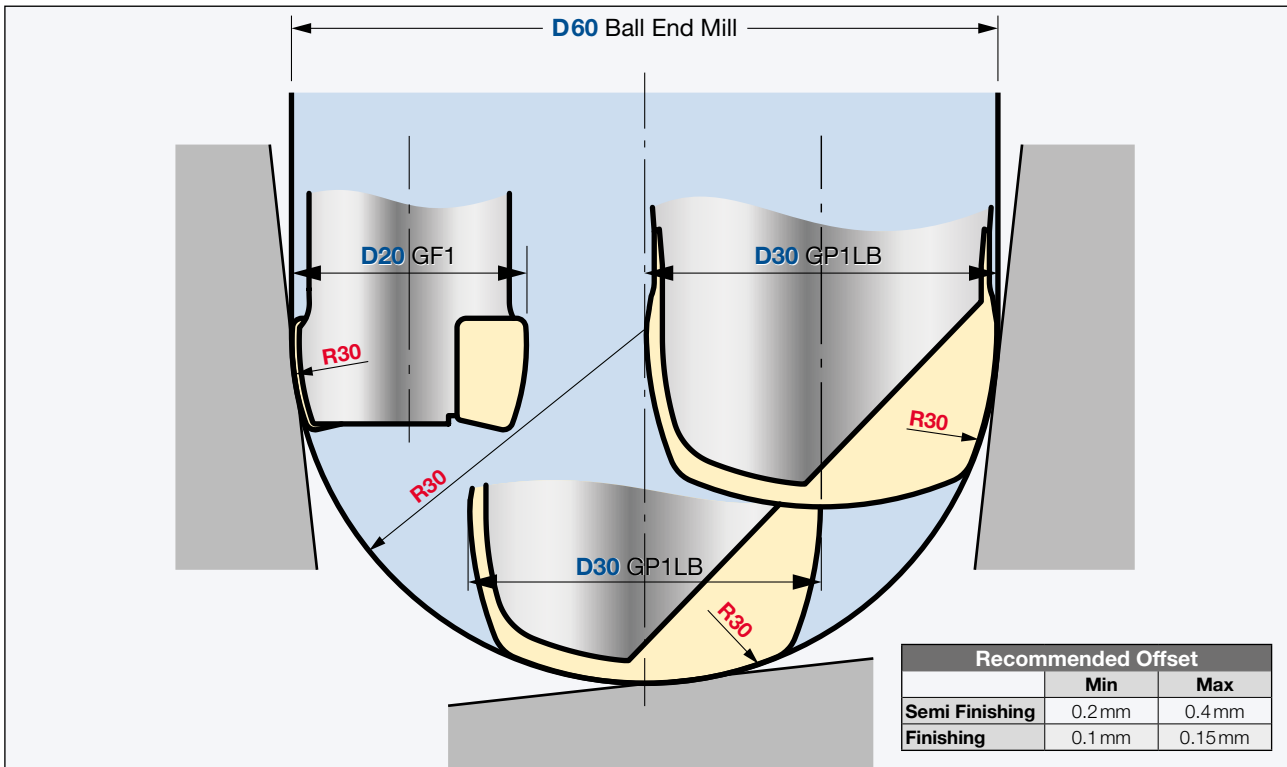

How can finishing time be reduced?

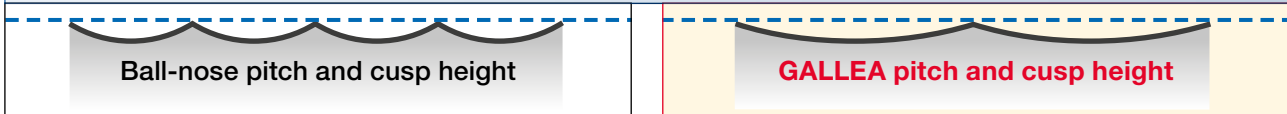

→ GALLEA: Larger pitch! Same cusp height!

Wall Finishing

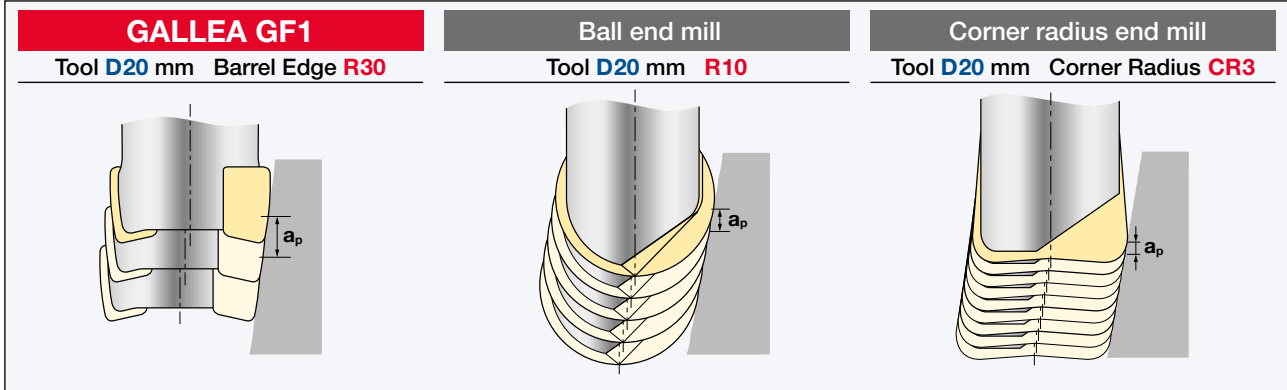

Bottom Finishing

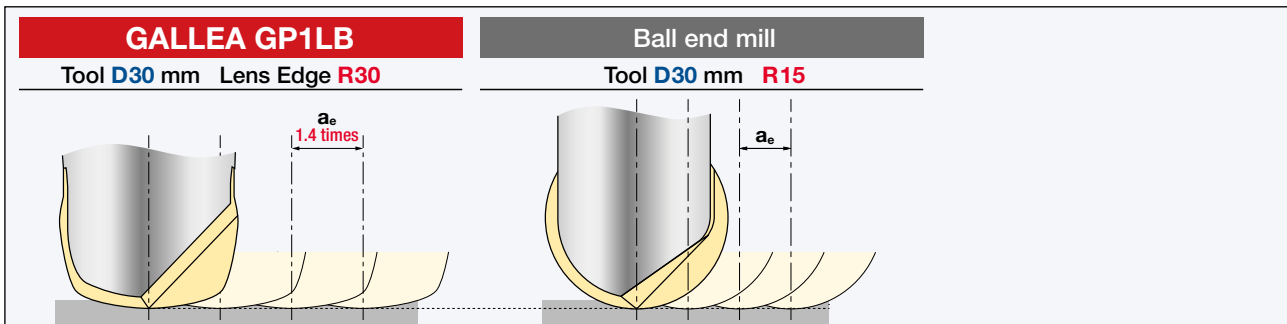



GALLEA Series | Overview

GF1 | Barrel

→ P. 4

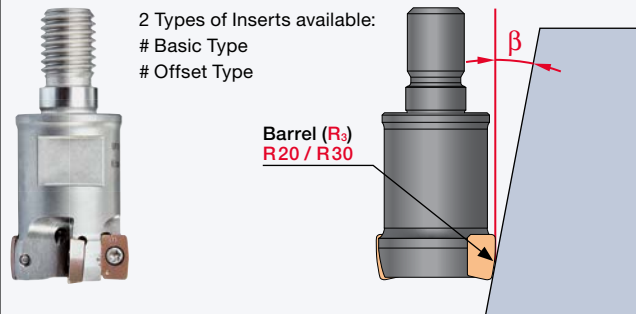

D16-D25 For Wall Finishing (up to 55HRC)

Inclination Capabilities

GF1				
	Basic type (GF1G)		Offset type (GF1T)	
	R20	R30	R20	R30
β	11°	7°	19°	12°

$\beta \triangleq$ maximum wall inclination angle nominal to tool / z-axis for Barrel (R_3)

GP1T | Taper Barrel

→ P. 6

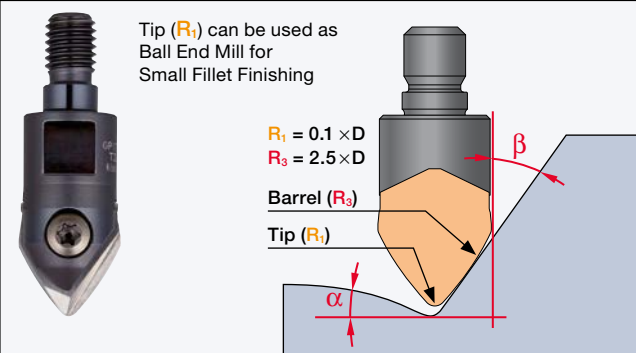

D12-D30 For Wall, Curved Bottom and Small Fillet Finishing (up to 62HRC)

Inclination Capabilities

GP1T	
D12-D30	
β_{min}	26°
β_{max}	43°
α	47°

$\beta \triangleq$ min/max wall inclination angle nominal to tool / z-axis for Barrel (R_3)

$\alpha \triangleq$ maximum bottom inclination angle for Tip (R_1)

GP1LB | Barrel, Lens

→ P. 8

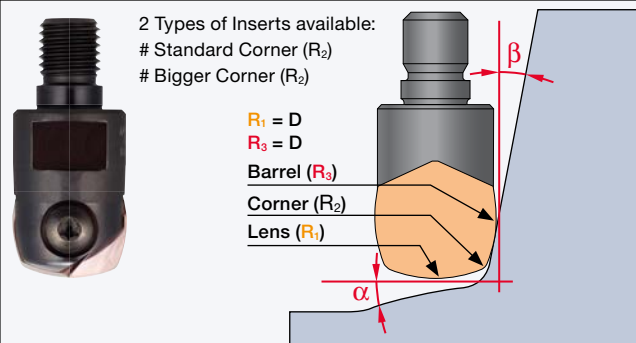

D16-D30 For Wall and Curved Bottom Finishing (up to 62HRC)

Inclination Capabilities

GP1LB					
	Standard Corner (R_2) (ZPHWxxx-LBxx)	Bigger Corner (R_2) (ZPHWxxx-LBxx-Rxx)			
	D16-D30	D16	D20	D25	D30
β	22°	17.78°	20.08°	16.21°	12.85°
α	22°	13°	13°	13°	13°

$\beta \triangleq$ maximum wall inclination angle nominal to tool / z-axis for Barrel (R_3)

$\alpha \triangleq$ maximum bottom inclination angle for Lens (R_1)

Note: Machining with Corner (R_2) in case of bigger inclination as shown above

GS4TN | Tangent Barrel

→ P. 10

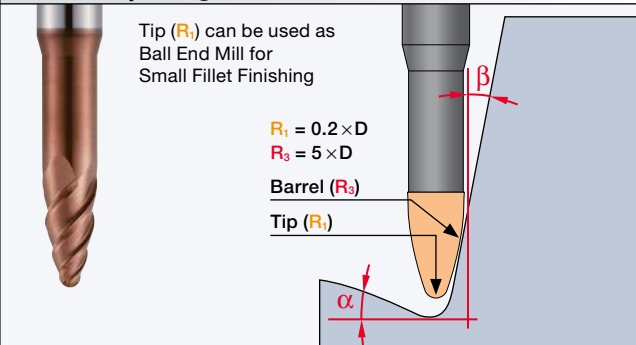

D2.5-D10 For Wall, Curved Bottom and Small Fillet Finishing (up to 69HRC)

Inclination Capabilities

GS4TN	
D2.5-D10	
β	20.364°
α	69.636°

$\beta \triangleq$ maximum wall inclination angle nominal to tool / z-axis for Barrel (R_3)

$\alpha \triangleq$ maximum bottom inclination angle for Tip (R_1)



GALLEA GF1 | High Efficiency Finishing Barrel Indexable Tool | Modular Type

V max High Speed	▽▽ Semi Finishing	▽▽▽ Finishing	HRC 55	No. of Teeth 2-4	
----------------------------	-----------------------------	-------------------------	------------------	----------------------------	--

A – Basic Type

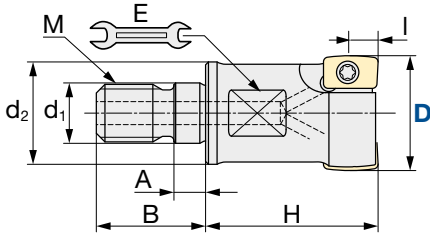

B – Offset Type

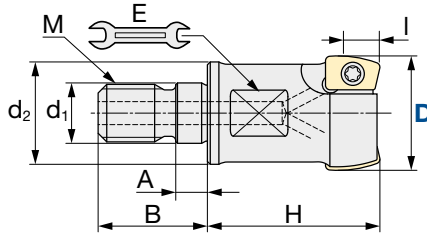

Diameter Holder only	Fastening Torque
-0.026/-0.06 mm	1.1 Nm

ID Code	Item Code	Type	Z	Size [mm]										Inserts
				D	H	I	d ₁	M	d ₂	A	B	E		
FH620	GF1G-2016M-2-M8	Basic type	2	16	25	4.75	8.5	M8	14	5.5	17	10	XPHW0903R-20 XPHW0903R-30	
FH621	GF1G-2020M-3-M10		3	20	30	4.75	10.5	M10	17.8	5.5	19	15		
FH622	GF1G-2025M-4-M10		4	25	30	4.75	10.5	M10	17.8	5.5	19	15		
FH623	GF1G-2025M-4-M12		4	25	35	4.75	12.5	M12	22.5	5.5	22	17		
FH624	GF1T-2016M-2-M8	Offset type	2	16	25	7.25	8.5	M8	14	5.5	17	10	YPHW0903R-20 YPHW0903R-30	
FH625	GF1T-2020M-3-M10		3	20	30	7.25	10.5	M10	17.8	5.5	19	15		
FH626	GF1T-2025M-4-M12		4	25	35	7.25	12.5	M12	22.5	5.5	22	17		

INSERTS | GF1

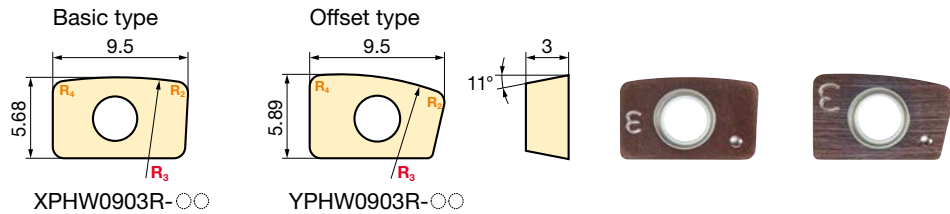

Item Code	Size [mm]		Grade		Type	Tolerance Class
			PN215	TH315		
	R ₃	R ₂ /R ₄	ID Code			
XPHW0903R-20	20	0.8	WF788	WF786	Basic type	H
XPHW0903R-30	30	0.8	WF789	WF787		
YPHW0903R-20	20	0.8	WF792	WF790	Offset type	
YPHW0903R-30	30	0.8	WF793	WF791		

Cutting edge definition

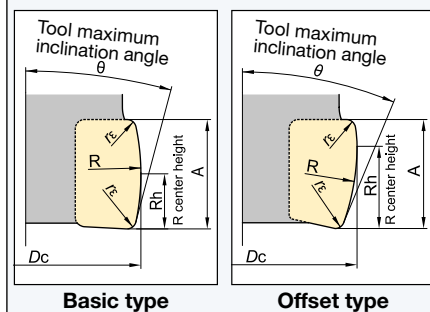

Barrel Edge Radius (**R₃**) will change depending on the combination of insert and tool diameter. Refer to table below.

Insert	Basic type						Offset type					
	XPHW0903R-20		XPHW0903R-30		YPHW0903R-20		YPHW0903R-30					
Tool dia. Dc (mm)	16	20	25	16	20	25	16	20	25	16	20	25
R₃ (mm)	20.14	20.00	19.93	30.38	30.00	29.82	20.18	20.00	19.91	30.33	30.00	29.81
Rh (mm)	4.75	4.75	4.75	4.75	4.75	4.75	7.25	7.25	7.25	7.25	7.25	7.25

Parts	Clamp Screw			Wrench	
Shape					
Cutter body	ID Code	Item Code	Fastening Torque	ID Code	Item Code
All	ET175	250-141(A)	1.1 Nm	ET013	104-T8



GALLEA GF1 | Recommended Cutting Conditions

Work piece material	Recommend grade & Target hardness (HRC)			Tool Diameter OH/Dia ratio Parameter	D 16 (Z2)			D 20 (Z3)			D 25 (Z4)		
	30	40	50		3-5 D	5-7 D	> 7 D	3-5 D	5-7 D	> 7 D	3-5 D	5-7 D	> 7 D
	Please find optimum value from the attached table.												
Carbon-Steel Alloy-Steel <30 HRC	PN215			V_c m/min	500	450	300	500	450	300	500	450	300
				n min ⁻¹	9947	8952	5968	7958	7162	4775	6366	5730	3820
				f_z mm/t	0.200	0.150	0.100	0.200	0.150	0.100	0.200	0.150	0.100
				V_f mm/min	3980	2690	1190	4770	3220	1430	5090	3440	1530
				a_p mm									
				a_e mm	<0.5	<0.5	<0.5	<0.5	<0.5	<0.5	<0.5	<0.5	<0.5
Pre-Hardened Steel 30-45 HRC	PN215			V_c m/min	400	300	200	400	300	200	400	300	200
	TH315			n min ⁻¹	7958	5968	3979	6366	4775	3183	5093	3820	2546
				f_z mm/t	0.200	0.150	0.100	0.200	0.150	0.100	0.200	0.150	0.100
				V_f mm/min	3180	1790	800	3820	2150	950	4070	2290	1020
				a_p mm									
				a_e mm	<0.5	<0.5	<0.5	<0.5	<0.5	<0.5	<0.5	<0.5	<0.5
Hardened Steels (45-55 HRC)	TH315			V_c m/min	250	200	150	250	200	150	250	200	150
				n min ⁻¹	4974	3979	2984	3979	3183	2387	3183	2546	1910
				f_z mm/t	0.150	0.120	0.080	0.150	0.120	0.080	0.150	0.120	0.080
				V_f mm/min	1490	950	480	1790	1150	570	1910	1220	610
				a_p mm									
				a_e mm	<0.3	<0.3	<0.3	<0.3	<0.3	<0.3	<0.3	<0.3	<0.3
Cast-Iron GG/GGG	PN215			V_c m/min	500	450	300	500	450	300	500	450	300
	TH315			n min ⁻¹	9947	8952	5968	7958	7162	4775	6366	5730	3820
				f_z mm/t	0.250	0.200	0.150	0.250	0.200	0.150	0.250	0.200	0.150
				V_f mm/min	4970	3580	1790	5970	4300	2150	6370	4580	2290
				a_p mm									
				a_e mm	<0.5	<0.5	<0.5	<0.5	<0.5	<0.5	<0.5	<0.5	<0.5

- In the same material group, please reduce V_c by 30% when using PN coating insert.
- These conditions are for general guidance; in actual machining conditions adjust the parameters according to your actual machine and workpiece conditions.

Correspondence table – a_p & cusp height:

$$a_p = 2\sqrt{R^2 - (R-H)^2}$$

R: R-Sizes of the insert
H: Cusp height

		Cusp height (mm)					
		Insert R-size					
a_p for	R20	0.4	0.57	0.69	0.8	0.89	1.26
	R30	0.49	0.69	0.85	0.98	1.1	1.55

Angle Range of Barrel (R_3)

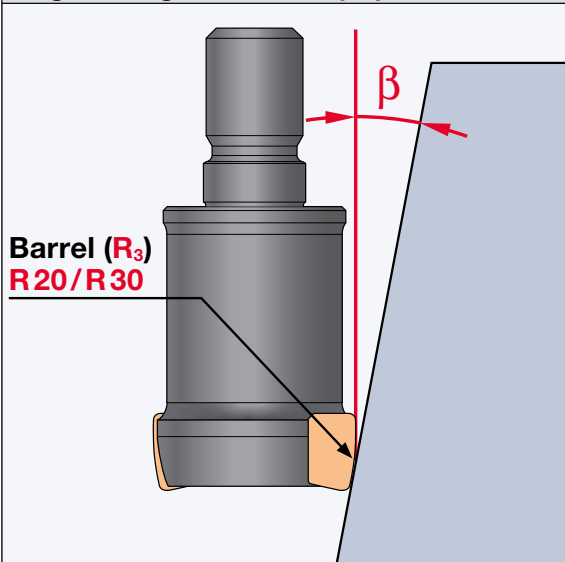

GF1				
Basic type (GF1G)		Offset type (GF1T)		
	R20	R30	R20	R30
β	11°	7°	19°	12°

$\beta \triangleq$ maximum wall inclination angle nominal to tool / z-axis for Barrel (R_3)

GALLEA GP1T | High Efficiency Finishing Taper Barrel Indexable Tool | Modular Type

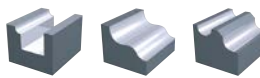
V max High Speed	▽▽ Semi Finishing	▽▽▽ Finishing	HRC 62	No. of Teeth 1	
----------------------------	-----------------------------	-------------------------	------------------	--------------------------	---

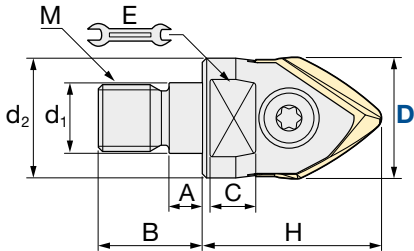

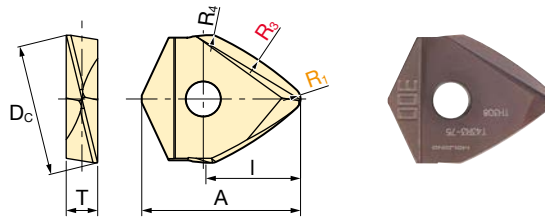

Fastening Torque	
D 12 = 4.9 Nm	D 20 = 6.9 Nm
D 16 = 4.9 Nm	D 25 = 9.8 Nm
	D 30 = 9.8 Nm

ID Code	Item Code	Z	Size [mm]									Insert
			D	H	d ₁	M	d ₂	A	B	C	E	
FH294	GP1T-12M-M6	2	12	26	6.5	M6	9.8	5.5	14.5	5	7	ZDHW-120-xxxx
FH295	GP1T-16M-M8		16	32	8.5	M8	12.8		17	8	10	ZDHW-160-xxxx
FH296	GP1T-20M-M10		20	38	10.5	M10	17.8		19	10	15	ZDHW-200-xxxx
FH297	GP1T-25M-M12		25		12.5	M12	20.8	22	9	17	ZDHW-250-xxxx	
FH298	GP1T-30M-M16		30	43	17	M16	28.8	6	23	11	22	ZDHW-300-xxxx

INSERTS | GP1T

Item Code	Size [mm]							Grade		Tolerance Class
	D _c	R ₁	R ₃	R ₄	I	A	T	PN215	TH308	
ZDHW-120-T43R1.2-30	12	1.20	30.00	0.98	8.60	17.60	3.20	WF812	WF817	H
ZDHW-160-T43R1.6-40	16	1.60	40.00	1.30	11.30	20.60	4.20	WF813	WF818	
ZDHW-200-T43R2-50	20	2.00	50.00	1.63	14.30	25.40	5.20	WF814	WF819	
ZDHW-250-T43R2.5-62.5	25	2.50	62.50	2.04	17.90	30.10	6.20	WF815	WF820	
ZDHW-300-T43R3-75	30	3.00	75.00	2.45	21.60	36.30	7.20	WF816	WF821	

- The insert can be set with "ABPF-type" cutter body
- Use solid barrel end mill, "GS4TN-type" for smaller diameter in size

Parts	Clamp Screw 			Wrench 		
Shape	ID Code	Item Code	Fastening Torque	ID Code	Item Code	
Cutter body						
GP1T-12M-M6	ET155	581-143	4.9 Nm	ET014	105-T20	
GP1T-16M-M8	ET156	581-144		6.9 Nm	ET009	101-T25S
GP1T-20M-M10	ET157	581-145	9.8 Nm		ET167	105-T30A
GP1T-25M-M12	ET168	581-146				
GP1T-30M-M16	ET169	581-147				

→ Set-up Procedures of Inserts

- 1** Clean the insert seat: Using air-blow or alike, clean the seat.
- 2** Put in the insert with its top positioned to the screw-tightening side of the tool body.

- 3** Tighten the clamp screw with the special wrench.
Please do not press down the insert during this tightening process.

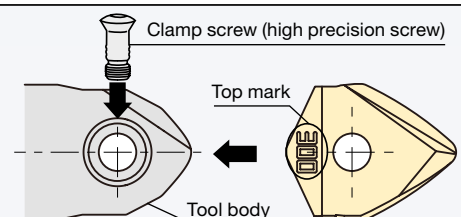



GALLEA GP1T | Recommended Cutting Conditions

Workpiece material	Recommended grade & target hardness (HRC)				Tool Dia. Parameter	D12			D16			D20			D25			D30		
	30	40	50	60		Corner milling	Semi	Finishing	Corner milling	Semi	Finishing	Corner milling	Semi	Finishing	Corner milling	Semi	Finishing	Corner milling	Semi	Finishing
	Cutting Edge (R)					Tip (R1.2)	Barrel (R30)		Tip (R1.6)	Barrel (R40)		Tip (R2)	Barrel (R50)		Tip (R2.5)	Barrel (R62.5)		Tip (R3)	Barrel (R75)	
Carbon-Steel Alloy-Steel <30 HRC	PN215				V _c m/min	150	400	500	210	400	500	250	400	500	310	400	500	370	400	500
					n min ⁻¹	19894	10610	13263	19660	7958	9947	19894	6366	7958	19735	5093	6366	19629	4244	5305
					f _z mm/t	0.040	0.237	0.158	0.050	0.274	0.183	0.060	0.306	0.204	0.070	0.342	0.228	0.080	0.375	0.250
					V _r mm/min	1590	5030	4190	1970	4360	3630	2390	3900	3250	2760	3490	2910	3140	3180	2650
					a _p mm	0.100	optimum value in table		0.100	optimum value in table		0.100	optimum value in table		0.100	optimum value in table		0.100	optimum value in table	
					a _e mm	value in table	0.350	0.100	value in table	0.350	0.100	value in table	0.350	0.100	value in table	0.350	0.100	value in table	0.350	0.100
Pre-Hardened Steel 30 ~ 45 HRC	PN215 TH308				V _c m/min	150	360	450	210	360	450	250	360	450	310	360	450	370	360	450
					n min ⁻¹	19894	9549	11937	19660	7162	8952	19894	5730	7162	19735	4584	5730	19629	3820	4775
					f _z mm/t	0.040	0.237	0.158	0.050	0.274	0.183	0.060	0.306	0.204	0.070	0.342	0.228	0.080	0.375	0.250
					V _r mm/min	1590	4530	3770	1970	3920	3270	2390	3510	2920	2760	3140	2620	3140	2860	2390
					a _p mm	0.100	optimum value in table		0.100	optimum value in table		0.100	optimum value in table		0.100	optimum value in table		0.100	optimum value in table	
					a _e mm	value in table	0.350	0.100	value in table	0.350	0.100	value in table	0.350	0.100	value in table	0.350	0.100	value in table	0.350	0.100
Hardened steels (45 ~ 55 HRC)	TH308				V _c m/min	150	256	320	210	256	320	250	256	320	310	256	320	370	256	320
					n min ⁻¹	19894	6791	8488	19660	5093	6366	19894	4074	5093	19735	3259	4074	19629	2716	3395
					f _z mm/t	0.040	0.190	0.126	0.050	0.219	0.146	0.060	0.245	0.163	0.070	0.274	0.183	0.080	0.300	0.200
					V _r mm/min	1590	2580	2150	1970	2230	1860	2390	2000	1660	2760	1790	1490	3140	1630	1360
					a _p mm	0.080	optimum value in table		0.080	optimum value in table		0.080	optimum value in table		0.080	optimum value in table		0.080	optimum value in table	
					a _e mm	value in table	0.280	0.080	value in table	0.280	0.080	value in table	0.280	0.080	value in table	0.280	0.080	value in table	0.280	0.080
Hardened steels (55 ~ 62 HRC)	TH308				V _c m/min	150	224	280	210	224	280	250	224	280	310	224	280	370	224	280
					n min ⁻¹	19894	5942	7427	19660	4456	5570	19894	3565	4456	19735	2852	3565	19629	2377	2971
					f _z mm/t	0.040	0.190	0.126	0.050	0.219	0.146	0.060	0.245	0.163	0.070	0.274	0.183	0.080	0.300	0.200
					V _r mm/min	1590	2250	1880	1970	1950	1630	2390	1750	1460	2760	1560	1300	3140	1430	1190
					a _p mm	0.050	optimum value in table		0.050	optimum value in table		0.050	optimum value in table		0.050	optimum value in table		0.050	optimum value in table	
					a _e mm	value in table	0.175	0.050	value in table	0.175	0.050	value in table	0.175	0.050	value in table	0.175	0.050	value in table	0.175	0.050
Cast-Iron GG/GGG	PN215 TH308				V _c m/min	150	400	500	210	400	500	250	400	500	310	400	500	370	400	500
					n min ⁻¹	19894	10610	13263	19660	7958	9947	19894	6366	7958	19735	5093	6366	19629	4244	5305
					f _z mm/t	0.040	0.285	0.190	0.050	0.329	0.219	0.060	0.367	0.245	0.070	0.411	0.274	0.080	0.450	0.300
					V _r mm/min	1590	6040	5030	1970	5230	4360	2390	4680	3900	2760	4180	3490	3140	3820	3180
					a _p mm	0.100	optimum value in table		0.100	optimum value in table		0.100	optimum value in table		0.100	optimum value in table		0.100	optimum value in table	
					a _e mm	value in table	0.350	0.100	value in table	0.350	0.100	value in table	0.350	0.100	value in table	0.350	0.100	value in table	0.350	0.100

Overhang ratio L/D	V _c (m/min)	V _r (mm/min)
3D ~ 5D	70%	70%
5D ~ 6D	60%	60%
6D ~ 7D	50%	50%
> 7D	45%	45%

→ In the same material group, please reduce V_c by 30% when using PN coating insert.
 → RPM are based on the Nominal Diameter! Please calculate RPM according to real contact point and effective cutting diameter.
 → These conditions are for general guidance; in actual machining conditions adjust the parameters according to your actual machine and workpiece conditions.
 * please make adjustment based on the below table in the case of L/D > 3

Correspondence table - a_p / a_e & cusp height:

Barrel edge a_p (mm)

Insert Item code	Barrel R	Cusp height (mm)							
		0.0005	0.001	0.002	0.003	0.004	0.005	0.01	
ZDHW-120-T43R1.2-30	30	0.35	0.49	0.69	0.85	0.98	1.1	1.55	
ZDHW-160-T43R1.6-40	40	0.4	0.57	0.8	0.98	1.13	1.26	1.79	
ZDHW-200-T43R2-50	50	0.45	0.63	0.89	1.1	1.26	1.41	2	
ZDHW-250-T43R2.5-62.5	62.5	0.5	0.71	1	1.22	1.41	1.58	2.24	
ZDHW-300-T43R3-75	75	0.55	0.77	1.1	1.34	1.55	1.73	2.45	

$$a_p = 2\sqrt{R^2 - (R-H)^2}$$

(a_e)



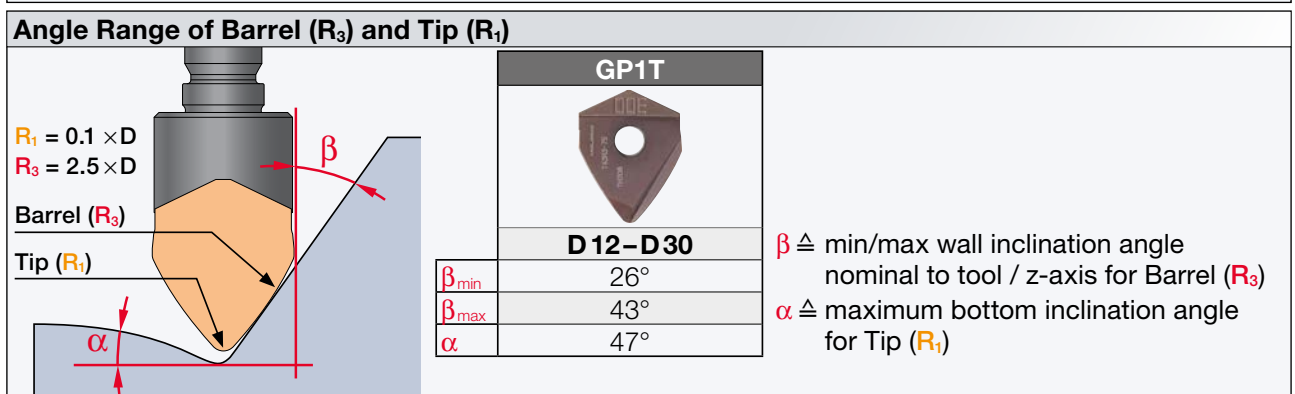

R: R-Sizes of insert
H: Cusp height

Tip edge a_e (mm)

Insert Item code	Tip R	Cusp height (mm)							
		0.0005	0.001	0.002	0.003	0.004	0.005	0.01	
ZDHW-120-T43R1.2-30	1.2	0.07	0.1	0.14	0.17	0.2	0.22	0.31	
ZDHW-160-T43R1.6-40	1.6	0.08	0.11	0.16	0.2	0.23	0.25	0.36	
ZDHW-200-T43R2-50	2	0.09	0.13	0.18	0.22	0.25	0.28	0.4	
ZDHW-250-T43R2.5-62.5	2.5	0.1	0.14	0.2	0.24	0.28	0.32	0.45	
ZDHW-300-T43R3-75	3	0.11	0.15	0.22	0.27	0.31	0.35	0.49	



GALLEA GP1LB | High Efficiency Finishing Lens Barrel Indexable Tool | Modular Type

V max High Speed	 Semi Finishing	 Finishing	HRC 62	No. of Teeth 2			
----------------------------	---	--	------------------	--------------------------	---	---	---

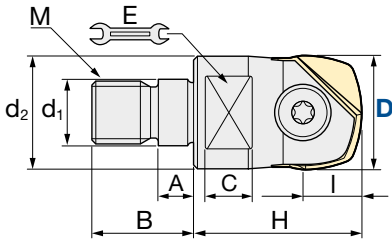

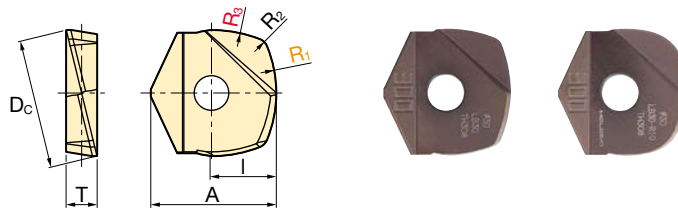

Diameter Insert only	Fastening Torque	
0/-0.02 mm	D 16 = 4.9 Nm	D 25 = 9.8 Nm
	D 20 = 6.9 Nm	D 30 = 9.8 Nm

ID Code	Item Code	Z	Size [mm]								Insert		
			D	H	I	d ₁	M	d ₂	A	B		C	E
FH286	GP1LB-16M-M8	2	16	32	8	8.5	M8	12.8	5.5	17	8	10	ZPHW-160-xxxx
FH287	GP1LB-20M-M10		20	38	10	10.5	M10	17.8		19	15	ZPHW-200-xxxx	
FH288	GP1LB-25M-M12		25		12.5	12.5	M12	20.8	22	10	17	ZPHW-250-xxxx	
FH289	GP1LB-30M-M16		30	43	15	17	M16	28.8	6	23	12	22	ZPHW-300-xxxx

INSERTS | GP1LB

Item Code	Size [mm]						Grade		Type	Tolerance Class
	D _c	R ₁	R ₃	R ₂	I	A	T	PN215		
ZPHW-160-LB16	16	16	1.5	8	16.6	4.2	WF802	WF806	Standard CR	H
ZPHW-200-LB20	20	20	1.9	10	20.3	5.2	WF803	WF807		
ZPHW-250-LB25	25	25	2.38	12.5	24.1	6.2	WF804	WF808		
ZPHW-300-LB30	30	30	2.85	15	29.1	7.2	WF805	WF809		
ZPHW-160-LB16-R5	16	16	5	8	16.6	4.2	WF822	WF826	Bigger CR	
ZPHW-200-LB20-R6	20	20	6	10	20.3	5.2	WF823	WF827		
ZPHW-250-LB25-R8	25	25	8	12.5	24.1	6.2	WF824	WF828		
ZPHW-300-LB30-R10	30	30	10	15	29.1	7.2	WF825	WF829		

• The insert can be set with "ABPF-type" cutter body

Parts	Clamp Screw			Wrench	
Shape					
Cutter body	ID Code	Item Code	Fastening Torque	ID Code	Item Code
GP1LB-16M-M8	ET156	581-144	4.9 Nm	ET014	105-T20
GP1LB-20M-M10	ET157	581-145	6.9 Nm	ET009	101-T25S
GP1LB-25M-M12	ET168	581-146	9.8 Nm	ET167	105-T30A
GP1LB-30M-M16	ET169	581-147			

→ Set-up Procedures of Inserts

- Clean the insert seat: Using air-blow or alike, clean the seat.
- Put in the insert with its top positioned to the screw-tightening side of the tool body.

- Tighten the clamp screw with the special wrench.
- Please do not press down the insert during this tightening process.

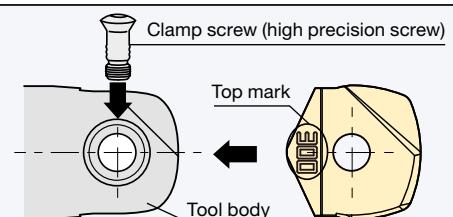



GALLEA GP1LB | Recommended Cutting Conditions

Workpiece material	Recommended grade & target hardness (HRC)				Tool Dia. (R)		D16 (R16)				D20 (R20)				D25 (R25)				D30 (R30)						
					Parameter		Semi		Finishing		Semi		Finishing		Semi		Finishing		Semi		Finishing				
	30	40	50	60	Cutting Edge	Lens	Barrel	Lens	Barrel	Lens	Barrel	Lens	Barrel	Lens	Barrel	Lens	Barrel	Lens	Barrel	Lens	Barrel				
Carbon-Steel Alloy-Steel <30 HRC	PN215				V _c m/min	480	400	600	500	480	400	600	500	480	400	600	500	480	400	600	500	480	400	600	500
					n min ⁻¹	9549	7958	11937	9947	7639	6366	9549	7958	6112	5093	7639	6366	5093	4244	6366	5305				
					f _t mm/t	0.274	0.274	0.183	0.183	0.306	0.306	0.204	0.204	0.342	0.342	0.228	0.228	0.375	0.375	0.250	0.250				
					V _r mm/min	5230	4360	4360	3630	4680	3900	3900	3250	4180	3490	3490	2910	3820	3180	3180	2650				
					a _p mm	0.350	value in table	0.100	value in table	0.350	value in table	0.100	value in table	0.350	value in table	0.100	value in table	0.350	value in table	0.100	value in table				
					a _e mm	value in table	0.350	value in table	0.100	value in table	0.350	value in table	0.100	value in table	0.350	value in table	0.100	value in table	0.350	value in table	0.100				
Pre-Hardened Steel 30-45 HRC	PN215 TH308				V _c m/min	440	360	550	450	440	360	550	450	440	360	550	450	440	360	550	450	440	360	550	450
					n min ⁻¹	8754	7162	10942	8952	7003	5730	8754	7162	5602	4584	7003	5730	4669	3820	5836	4775				
					f _t mm/t	0.274	0.274	0.183	0.183	0.306	0.306	0.204	0.204	0.342	0.342	0.228	0.228	0.375	0.375	0.250	0.250				
					V _r mm/min	4790	3920	4000	3270	4290	3510	3570	2920	3840	3140	3200	2620	3500	2860	2920	2390				
					a _p mm	0.350	value in table	0.100	value in table	0.350	value in table	0.100	value in table	0.350	value in table	0.100	value in table	0.350	value in table	0.100	value in table				
					a _e mm	value in table	0.350	value in table	0.100	value in table	0.350	value in table	0.100	value in table	0.350	value in table	0.100	value in table	0.350	value in table	0.100				
Hardened steels (45-55 HRC)	TH308				V _c m/min	336	256	420	320	336	256	420	320	336	256	420	320	336	256	420	320	336	256	420	320
					n min ⁻¹	6685	5093	8356	6366	5348	4074	6685	5093	4278	3259	5348	4074	3565	2716	4456	3395				
					f _t mm/t	0.219	0.219	0.146	0.146	0.245	0.245	0.163	0.163	0.274	0.274	0.183	0.183	0.300	0.300	0.200	0.200				
					V _r mm/min	2930	2230	2440	1860	2620	2000	2180	1660	2340	1790	1950	1490	2140	1630	1780	1360				
					a _p mm	0.280	value in table	0.080	value in table	0.280	value in table	0.080	value in table	0.280	value in table	0.080	value in table	0.280	value in table	0.080	value in table				
					a _e mm	value in table	0.280	value in table	0.080	value in table	0.280	value in table	0.080	value in table	0.280	value in table	0.080	value in table	0.280	value in table	0.080				
Hardened steels (55-62 HRC)	TH308				V _c m/min	304	224	380	280	304	224	380	280	304	224	380	280	304	224	380	280	304	224	380	280
					n min ⁻¹	6048	4456	7560	5570	4838	3565	6048	4456	3871	2852	4838	3565	3226	2377	4032	2971				
					f _t mm/t	0.219	0.219	0.146	0.146	0.245	0.245	0.163	0.163	0.274	0.274	0.183	0.183	0.300	0.300	0.200	0.200				
					V _r mm/min	2650	1950	2210	1630	2370	1750	1980	1460	2120	1560	1770	1300	1940	1430	1610	1190				
					a _p mm	0.175	value in table	0.050	value in table	0.175	value in table	0.050	value in table	0.175	value in table	0.050	value in table	0.175	value in table	0.050	value in table				
					a _e mm	value in table	0.175	value in table	0.050	value in table	0.175	value in table	0.050	value in table	0.175	value in table	0.050	value in table	0.175	value in table	0.050				
Cast-Iron GG/GGG	PN215 TH308				V _c m/min	480	400	600	500	480	400	600	500	480	400	600	500	480	400	600	500	480	400	600	500
					n min ⁻¹	9549	7958	11937	9947	7639	6366	9549	7958	6112	5093	7639	6366	5093	4244	6366	5305				
					f _t mm/t	0.329	0.329	0.219	0.219	0.367	0.367	0.245	0.245	0.411	0.411	0.274	0.274	0.450	0.450	0.300	0.300				
					V _r mm/min	6280	5230	5230	4360	5610	4680	4680	3900	5020	4180	4180	3490	4580	3820	3820	3180				
					a _p mm	0.350	value in table	0.100	value in table	0.350	value in table	0.100	value in table	0.350	value in table	0.100	value in table	0.350	value in table	0.100	value in table				
					a _e mm	value in table	0.350	value in table	0.100	value in table	0.350	value in table	0.100	value in table	0.350	value in table	0.100	value in table	0.350	value in table	0.100				

→ In the same material group, please reduce V_c by 30% when using PN coating insert.
 → RPM are based on the Nominal Diameter! Please calculate RPM according to real contact point and effective cutting diameter.
 → These conditions are for general guidance; in actual machining conditions adjust the parameters according to your actual machine and workpiece conditions.

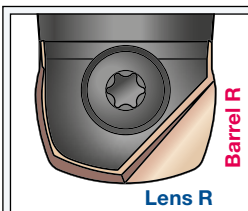

- For machining shapes that make heavy use of **Lens R**, refer to the **Lens edges** cutting conditions in the above table.
- For machining shapes that make heavy use of **Barrel R**, refer to the **Barrel edges** cutting conditions.
- For machining shapes that use both **Lens R** & **Barrel R** equally, refer to the **Lens edges** cutting conditions in the table at left

* please make adjustment based on the below table in the case of L/D > 3

Overhang ratio L/D	V _c (m/min)	V _r (mm/min)
< 3 D	100%	100%
3 D ~ 5 D	70%	70%
5 D ~ 6 D	60%	60%
6 D ~ 7 D	50%	50%
> 7 D	45%	45%

Correspondence table – a_p / a_e & cusp height:

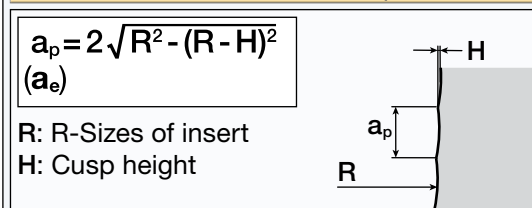

Barrel edge a_p (mm) or Lens edge a_e (mm)

Insert	Cusp height (mm)							
	Item code	R	0.001	0.002	0.003	0.004	0.005	0.01
a _p for	ZPHW-160-LB16	16	0.36	0.51	0.62	0.72	0.8	1.13
	ZPHW-200-LB20	20	0.40	0.57	0.69	0.8	0.89	1.26
	ZPHW-250-LB25	25	0.45	0.63	0.77	0.89	1	1.41
	ZPHW-300-LB30	30	0.49	0.69	0.85	0.98	1.1	1.55

Angle Range of Barrel (R₃) and Lens (R₁)

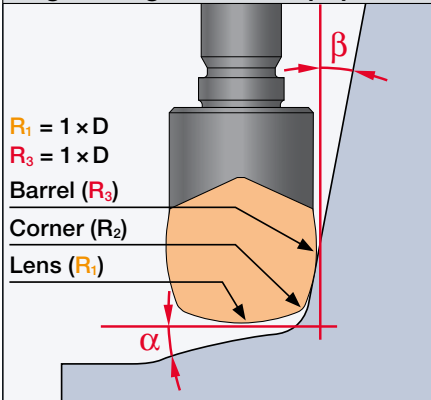

GP1LB					
	Standard Corner (R ₂) (ZPHWxxx-LBxx)	Bigger Corner (R ₂) (ZPHWxxx-LBxx-Rxx)			
	D 16 - D 30	D 16	D 20	D 25	D 30
β	22°	17.78°	20.08°	16.21°	12.85°
α	22°	13°	13°	13°	13°

Note: Machining with Corner (R₂) in case of bigger inclination as shown above

GALLEA GS4TN | High Efficiency Finishing Tangent Barrel Solid Carbide Tool

V max High Speed	▽▽ Semi Finishing	▽▽▽ Finishing	HRC 69	No. of Teeth 4
----------------------------	-----------------------------	-------------------------	------------------	--------------------------

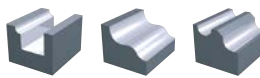
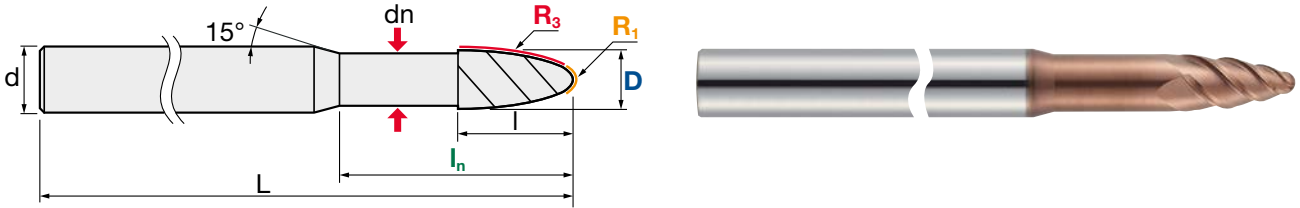
Carbide Ultra Micro Grain	TH3 Nano-PVD Coating
-------------------------------------	--------------------------------

Helix Angle	Form Tol.	d Tol.
45°	± 0.01 mm	h5

ID Code	Item Code	Z	Size [mm]							
			D	R ₁	R ₃	l _n	l	dn	L	d
EP1841	GS4TN-2.5-12.5R-TH3	4	2.5	0.5	12.5	10	4.68	2.4	50	4
EP1842	GS4TN-3.75-18.75R-TH3		3.75	0.75	18.75	15	7.01	3.65	50	4
EP1843	GS4TN-5-25R-TH3		5	1	25	20	9.35	4.8	60	6
EP1844	GS4TN-7.5-37.5R-TH3		7.5	1.5	37.5	30	14.03	7.3	75	8
EP1845	GS4TN-10-50R-TH3		10	2	50	40	18.70	9.5	100	12

- There is no regrinding compatibility for this tool.
- For the large diameter in size, use the indexable end mill **GP1T**.

About tool shape

Barrel (R₃) of **GS4TN** has a shape that connects **Tip (R₁)** and **Tool diameter** with double arc. See the figure on the right.

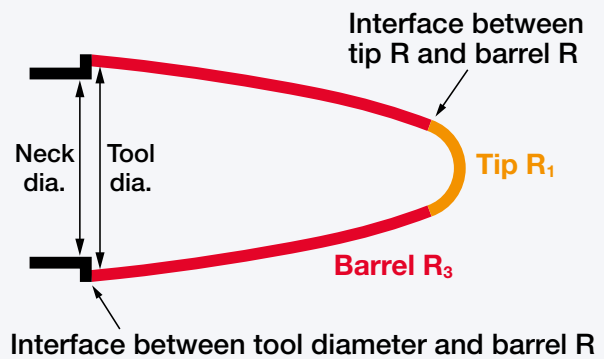



GALLEA GS4TN | Recommended Cutting Conditions

Workpiece material	Tool Dia. Cutting Edge (R)	D 2.5		D 3.75		D 5		D 7.5		D 10	
		Tip (R 0.5)	Barrel (R 12.5)	Tip (R 0.75)	Barrel (R 18.75)	Tip (R 1)	Barrel (R 25)	Tip (R 1.5)	Barrel (R 37.5)	Tip (R 2)	Barrel (R 50)
Carbon steel, Alloy steel (<30 HRC)	V _c m/min	130	185	185	185	185	185	185	185	185	185
	n min ⁻¹	41380	23555	39258	15703	29444	11777	19629	7852	14722	5889
	f _z mm/t	0.019	0.032	0.028	0.043	0.037	0.054	0.040	0.063	0.049	0.071
	V _f mm/min	3140	3020	4400	2670	4360	2540	3140	1980	2890	1680
	a _p mm	0.049	optimum value in table	0.060	optimum value in table	0.069	optimum value in table	0.085	optimum value in table	0.098	optimum value in table
	a _e mm	optimum value in table	0.050-0.100	optimum value in table	0.050-0.100	optimum value in table	0.050-0.100	optimum value in table	0.050-0.100	optimum value in table	0.050-0.100
Pre-Hardened Steel 30 – 45 HRC	V _c m/min	130	150	150	150	150	150	150	150	150	150
	n min ⁻¹	41380	19099	31831	12732	23873	9549	15915	6366	11937	4775
	f _z mm/t	0.018	0.032	0.027	0.048	0.036	0.059	0.039	0.070	0.047	0.076
	V _f mm/min	2980	2480	3440	2470	3440	2250	2480	1770	2240	1450
	a _p mm	0.049	optimum value in table	0.060	optimum value in table	0.069	optimum value in table	0.085	optimum value in table	0.098	optimum value in table
	a _e mm	optimum value in table	0.050-0.100	optimum value in table	0.050-0.100	optimum value in table	0.050-0.100	optimum value in table	0.050-0.100	optimum value in table	0.050-0.100
Hardened steel (45 ~ 55 HRC)	V _c m/min	130	140	140	140	140	140	140	140	140	140
	n min ⁻¹	41380	17825	29709	11884	22282	8913	14854	5942	11141	4456
	f _z mm/t	0.018	0.028	0.027	0.037	0.036	0.047	0.038	0.059	0.040	0.063
	V _f mm/min	2980	1960	3210	1780	3210	1670	2260	1400	1780	1120
	a _p mm	0.045	optimum value in table	0.055	optimum value in table	0.063	optimum value in table	0.077	optimum value in table	0.089	optimum value in table
	a _e mm	optimum value in table	0.050-0.100	optimum value in table	0.050-0.100	optimum value in table	0.050-0.100	optimum value in table	0.050-0.100	optimum value in table	0.050-0.100
Hardened steel (55 ~ 62 HRC)	V _c m/min	115	115	115	115	115	115	115	115	115	115
	n min ⁻¹	36606	14642	24404	9762	18303	7321	12202	4881	9151	3661
	f _z mm/t	0.016	0.031	0.024	0.042	0.032	0.049	0.035	0.063	0.037	0.068
	V _f mm/min	2340	1830	2340	1630	2340	1440	1710	1230	1350	990
	a _p mm	0.045	optimum value in table	0.055	optimum value in table	0.063	optimum value in table	0.077	optimum value in table	0.089	optimum value in table
	a _e mm	optimum value in table	0.010-0.050	optimum value in table	0.010-0.050	optimum value in table	0.010-0.050	optimum value in table	0.010-0.050	optimum value in table	0.010-0.050
Hardened steel (62 ~ 69 HRC)	V _c m/min	100	100	100	100	100	100	100	100	100	100
	n min ⁻¹	31831	12732	21221	8488	15915	6366	10610	4244	7958	3183
	f _z mm/t	0.013	0.028	0.020	0.036	0.027	0.043	0.030	0.055	0.038	0.060
	V _f mm/min	1660	1400	1700	1230	1720	1090	1270	930	1210	770
	a _p mm	0.040	optimum value in table	0.049	optimum value in table	0.057	optimum value in table	0.069	optimum value in table	0.080	optimum value in table
	a _e mm	optimum value in table	0.010-0.050	optimum value in table	0.010-0.050	optimum value in table	0.010-0.050	optimum value in table	0.010-0.050	optimum value in table	0.010-0.050

➔ RPM are based on the Nominal Diameter! Please calculate RPM according to real contact point and effective cutting diameter.

- Note:**
1. Use the appropriate coolant for the work material and machining shape.
 2. Use a machine having as high rigidity and high accuracy as possible.
 3. These conditions are for general guidance; in actual machining conditions adjust the parameters according to your actual machine and workpiece conditions.
 4. If the rpm of the machine is low, lower the feed rate also to put the rpm and feed rate in the same ratio.

Correspondence table – a_p & cusp height:

$$a_p = 2\sqrt{R^2 - (R-H)^2}$$

R: R-Sizes of insert
H: Cusp height

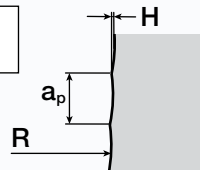

a _p for	Item code	Barrel R	Cusp height (mm)					
			0.0001	0.0003	0.0005	0.001	0.003	0.005
a _p for	GS4TN-2.5-12.5R-TH3	12.5	0.10	0.17	0.22	0.32	0.55	0.71
	GS4TN-3.75-18.75R-TH3	18.75	0.12	0.21	0.27	0.39	0.67	0.87
	GS4TN-5-25R-TH3	25	0.14	0.24	0.32	0.45	0.77	1.00
	GS4TN-7.5-37.5R-TH3	37.5	0.17	0.30	0.39	0.55	0.95	1.22
	GS4TN-10-50R-TH3	50	0.20	0.35	0.45	0.63	1.10	1.41

Angle Range of Barrel (R₃) and Tip (R₁)

R₁ = 0.2 × D
R₃ = 5 × D

Barrel (R₃)
Tip (R₁)

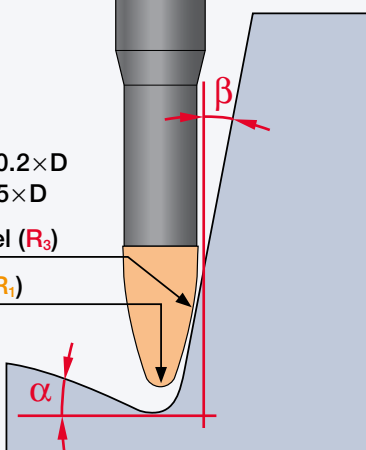

GS4TN

D 2.5 – D 10

β	20.364°
α	69.636°

β ≙ maximum wall inclination angle nominal to tool / z-axis for Barrel (R₃)

α ≙ maximum bottom inclination angle for Tip (R₁)

➔ For more information about Modular Tools and available Shanks please check our brochures:

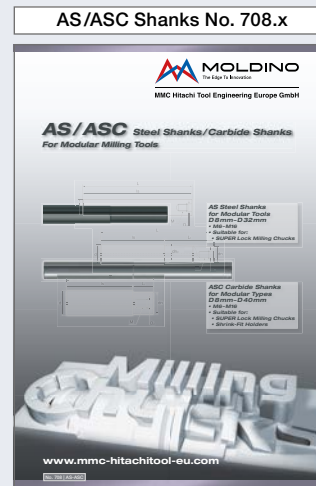

⚠ Attention on Safety

1. Cautions regarding handling

- (1) When removing the tool from its case (packaging), be careful that the tool does not pop out or is dropped. Be particularly careful regarding contact with the tool flutes.
- (2) When handling tools with sharp cutting flutes, be careful not to touch the cutting flutes directly with your bare hands.

2. Cautions regarding mounting

- (1) Before use, check the outside appearance of the tool for scratches, cracks, etc. and that it is firmly mounted in the collet chuck, etc.
- (2) When preparing for use, be sure that the inserts are firmly mounted in place and that they are firmly mounted on the arbor, etc.
- (3) If abnormal chattering, etc. occurs during use, stop the machine immediately and remove the cause of the chattering.

3. Cautions during use

- (1) Before use, confirm the dimensions and direction of rotation of the tool and milling work material.
- (2) The numerical values in the standard cutting conditions table should be used as criteria when starting new work. The cutting conditions should be adjusted as appropriate when the cutting depth is large, the rigidity of the machine being used is low, or according to the conditions of the work material.
- (3) Cutting tools are made of a hard material. During use, they may break and fly off. In addition, cutting chips may also fly off. Since there is a danger of injury to workers, fire, or eye damage from such flying pieces, a safety cover should be attached when work is performed and safety equipment such as safety goggles should be worn to create a safe environment for work.
- (4) There is a risk of fire or inflammation due to sparks, heat due to breakage, and cutting chips. Do not use where there is a risk of fire or explosion. Please caution of fire while using oil base coolant, fire prevention is necessary.
- (5) Do not use the tool for any purpose other than that for which it is intended.

4. Cautions regarding regrinding

- (1) If regrinding is not performed at the proper time, there is a risk of the tool breaking. Replace the tool with one in good condition, or perform regrinding.
- (2) Grinding dust will be created when regrinding a tool. When regrinding, be sure to attach a safety cover over the work area and wear safety clothes such as safety goggles, etc.
- (3) This product contains the specified chemical substance cobalt and its inorganic compounds. When performing regrinding or similar processing, be sure to handle the processing in accordance with the local laws and regulations regarding prevention of hazards due to specified chemical substances.

“GALLEA” and “MOLDINO” are registered trademarks of Mitsubishi Hitachi Tool Engineering, Ltd. in Japan.

Specifications for the products listed in this catalog are subject to change without notice due to replacement or modification.

Always up to date: Please check our P50 QuickFinder

P50 PRODUCTIONS50®
QuickFinder www.moldino.eu/quickfinder

MMC Hitachi Tool Engineering Europe GmbH

Itterpark 12 · 40724 Hilden · Germany · Phone +49 (0) 21 03-24 82-0 · Fax +49 (0) 21 03-24 82-30

E-Mail info@mmc-hitachitool-eu.com · Internet www.moldino.eu

© 2019 by MMC Hitachi Tool Engineering Europe GmbH · 2nd Edition · Printed in Germany